



# Models

## N/1.9E Manual

## N/1.9E Cook / Hold



Model N/1.9E  
(Digital Control Shown)



### Standard Features

- 9 spit capacity
- Individual motors per spit
- Rotisserie cooking in a small space
- Allows for 1 – 9 birds per batch
- Convection fans for efficient cooking
- Water drip tray for humidified cooking
- 180 degree merchandising view



### Options

- Manual thermostat
- Cook and Hold
- Oven rack insert with 9 trays for convection cooking
- Basket spits for other menu items
- Wall mounted bracket

Models N/1.9E Manual N/1.9E Cook / Hold

Technical Data		N/1.9E
Cooking Type		Batch
Power Supply		Electric
Supply Voltage (Please Specify)		208 - 240
Phase • Frequency (Special Voltages Available)		3+N • 60 Hz
Power kW		5.8
# Elements • kW Each • Total Element kW		2 • 2.4 • 4.8
Spit Motors • Wattage • Total Wattage		9 • 50 • 450
Fan Motors • Wattage • Total Wattage		2 • 50 • 100
Digital Timer Wattage		5
Amperage – 1 Ph @ 208V, 220V, 240V		26 • 24 • 22
Amperage – 3 Ph @ 208V, 220V, 240V		15 • 14 • 13
Net Weight		205
Dimension		
	Height	35½"
	Depth	25½"
	Width	24"
Spits • Distance Between Spits		9" • 7"
Clearance Off Adjacent Walls		1"

# Models

## N/1.9E Manual

## N/1.9E Cook / Hold

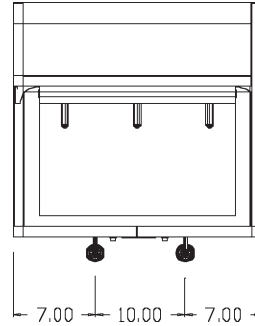

Top View

### Ventilation

Electric units do not normally require air evacuation.

### Drive Mechanism

Individual motors drive each spit.

### Installation Requirements

Licensed electrician for connections and checkout. Placement of this machine is critical since it is hot. Plan carefully. A wall mounting unit is available.

### Front Facings

Machine is made with high grade polished stainless. Accent striped frames are black powder coated.

### Service, Maintenance, and Construction

Full rear service panel allows easy access to all working parts. The 1.9E is easily cleaned from the front with stainless steel removable panels and glass, enabling the user to meet all sanitary and hygienic requirements with a minimum of time and effort. Removable interior panels allow for quick maintenance and minimal cleaning effort. The interior cooking area is constructed completely of high grade stainless steel. Insulation is complete on all top and side panels. Rigid frame design ensures strength.

### Safety

The vertically hinged, tempered glass service doors open completely, with the use of large handle knobs which profiles below the glass to assist and prevent the possibility of the operator burning his hands or arms. Electrical components are located behind the control panel in an area fully insulated from the interior cooking space. Control panel information, with clear, legible graphics, eliminates confusion for even the novice operator.

\*Specifications are subject to change without notice. When ordering please specify voltage, phase and frequency requirements.

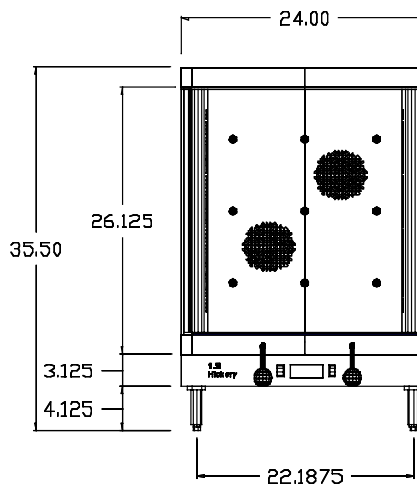

Front View

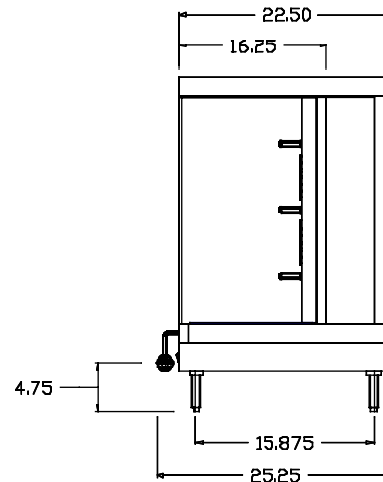

Side View



Hickory Industries, Inc. • 4900 Westside Avenue • North Bergen, NJ 07047

201-223-0050 • Fax 201-223-0950

www.hickorybbq.com • email: hickorybbqs@aol.com