

Hickory Rotisseries

Models: N/5.5 G



Machine Type	N / 5. 5 G
Total Power Rating	20,000 Btu
Burner / Spits	1 Burners with 5 Spits
Gas Category	Natural Gas, LPG
Fittings	1 Infra-Red Gas Generators
Ignition	1 Electronic Ignitor
Delivery Date:	Final Inspection:

FOR YOUR SAFETY

Do Not Store or use gasoline or other flammable vapors or liquids in the vicinity of this or any other appliance.

WARNING: Improper installation, adjustment, alteration, service or maintenance can cause property damage, injury or death. Read the Installation, operating and maintenance instructions thoroughly before installing or servicing this equipment.

POUR VOTRE SÉCURITÉ

Ne pas entreposer ou utiliser de l'essence ou d'autres vapeurs ou liquides inflammables au voisinage de cet appareil ou de tout autre appareil.

AVERTISSEMENT: Une mauvaise installation, le réglage, la modification, un service ou d'entretien peut causer des dommages matériels, des blessures ou la mort. Lire l'installation, l'exploitation et la maintenance instructions avant l'installation ou l'entretien de cet équipement.

Please copy, cutout and place in a prominent location.

What To Do If You Smell A Gas Odor

Natural gas is lighter than air, and it has a very high ignition temperature. For your protection, The Gas Company adds a distinctive odor to natural gas, so leaks are easily detected.

If you smell a Natural gas or a Propane gas odor:

- **DON'T panic.**
- **DON'T light a match, candle or cigarette.**
- **DON'T turn electrical appliances or lights on or off.**

For safety, a shut-off valve was installed on this appliance. If a leak occurs at this appliance, the valve will permit you to turn off the gas at the appliance rather than shutting off all gas service at the meter.

SHUT off the appliance shut-off valve.



From a safe location, call your local Gas Company 24 hours a day, seven days a week; or call **9-1-1**.

S'il vous plaît copier , découpe et placer dans un endroit bien en vue.

Que faire si vous sentez une odeur de gaz

Le gaz naturel est plus léger que l'air , et il a une très haute température d'allumage . Pour votre protection, La Compagnie du Gaz ajoute une odeur caractéristique du gaz naturel , de sorte que les fuites sont facilement détectées.

Si vous sentez un gaz naturel ou une odeur de gaz propane :

- **Ne paniquez pas.**
- **NE PAS allumer une allumette , bougie ou cigarette.**
- **NE PAS tourner les appareils électriques ou les lumières ou désactiver**

Pour plus de sécurité , une soupape d'arrêt a été installé sur l'appareil. Si une fuite se produit à cet appareil , la vanne vous permettra de couper le gaz à l'appareil plutôt que couper tous les services de gaz au compteur .

Fermez le robinet d'arrêt appareil.

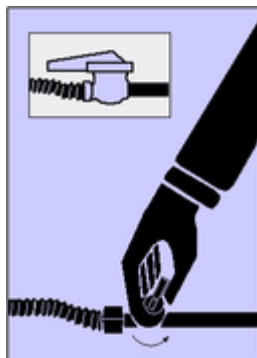

D'un endroit sûr , appelez votre compagnie de gaz locale

INTENDED FOR OTHER THAN HOUSEHOLD USE
OVEN MUST BE KEPT CLEAR OF COMBUSTIBLES AT ALL TIMES

IMPORTANT INSTRUCTIONS

After the gas supply has been connected to your unit, it is extremely important to check piping for possible leaks. To do this, use soap and water solutions, or solutions which are expressly made for this purpose. DO NOT USE matches, candles, flames, or other sources of ignitions since these methods are extremely dangerous.

In a prominent location post instructions to be followed in the event you smell gas. Obtain these instructions from your local gas supplier.

FOR YOUR SAFETY

Do not store or use gasoline or other flammable vapors and liquids in the vicinity of this or any other appliance.

WARNING

Improper installation, adjustment, alteration, service or maintenance can cause property damage, injury or death. Read the Installation, Operating and Maintenance Instructions thoroughly before installing or servicing this equipment. Initial heating of oven may generate smoke or fumes and must be done in a well ventilated area. Overexposure to smoke or fumes may cause nausea or dizziness.



As a safety precaution, disconnect the power supply to the appliance before cleaning or servicing this appliance.



Instruction Plate:

Before lighting this piece of equipment, ensure that the ventilation hood is turned on

1. Turn on Lights, Motor and Temperature switches.
2. Press "Read" and toggle the "Up" and "Down" keys to recipe 1
3. Press the "Start Stop" button
4. Infra-Red gas burner will turn on. In case of flame failure, turn Temperature switch off. Wait five minutes before relighting the appliance.

DESTINÉS À AUTRE QUE L'UTILISATION DES MÉNAGES
FOUR DOIT RESTER CLAIR DE COMBUSTIBLES EN TOUT TEMPS

INSTRUCTIONS IMPORTANTES

Après l'alimentation en gaz a été connecté à votre appareil , il est extrêmement important de vérifier la tuyauterie pour les fuites possibles . Pour ce faire , utilisez l'eau et du savon ou des solutions , des solutions qui sont expressément à cette fin. NE PAS UTILISER allumettes, bougies , de flammes ou d'autres sources d' allumages puisque ces méthodes sont extrêmement dangereuses.

Dans un éminent instructions emplacement de poste à suivre en cas d'odeur de gaz . Obtenir ces les instructions de votre fournisseur de gaz local .

POUR VOTRE SÉCURITÉ

Do not store or use gasoline or other flammable vapors and liquids in the vicinity of this or any other appliance.

ATTENTION

Une installation, un réglage, une modification , un service ou d'entretien peuvent causer des dommages matériels, des blessures ou la mort. Lire l'installation, fonctionnement et de maintenance avant d'installer ou d'entretenir cet équipement . Le chauffage initial du four peut générer des fumées ou de vapeurs et doit être fait dans un endroit bien ventilé . La surexposition aux fumées ou de vapeurs peut causer des nausées ou des vertiges.



Par mesure de sécurité , débrancher l'alimentation électrique l'appareil avant le nettoyage ou l'entretien de cet appareil .



Instruction Plate:

Avant d'allumer cette pièce d'équipement , d'assurer que le capot de ventilation est activée

1. Allumer les lumières , le moteur et les interrupteurs de température. 2. Appuyez sur "Read" et activer les touches "Down" "Up" et à la recette 1 3. appuie sur le "Start Stop" bouton 4. brûleur à gaz infrarouge se met en marche. En cas d'échec de la flamme , tour Température éteindre . Attendez cinq minutes avant de rallumer l'appareil .



Electrical diagrams for this appliance are located behind the right side cover as well as in this manual.

ENSURE YOU DISCONNECT THE POWER BEFORE OPENING SIDE ENCLOSURE!



Schémas électriques pour cet appareil sont situés derrière le capot latéral droit, ainsi que dans ce manuel.

ASSURER vous débranchez le AVANT D'OUVRIR SIDE ENCEINTE !

INSTALLATION GUIDELINES

GAS

Gas installation must conform with local codes, or in the absence of local codes, with the **National Fuel Gas Code, ANSI 2223.1 /NFPA 54**, or the **Natural Gas and Propane Installation Code, CSA B749.1**

ELECTRICAL INSTALLATION

This appliance, when installed, must be electrically grounded in accordance with local codes, or in the absence of local codes, with the **National Electrical Code, ANSI/NFPA 70**, or the **Canadian Electrical Code, CSA C22.2**, as applicable. For your convenience, this appliance has been wired with a NEMA 5-15 cord and plug and should be plugged in to a corresponding NEMA 5-15 receptacle. The grounding prong **SHOULD NOT BE CUT. Cutting the grounding prong will void the manufacturers warranty**

PRESSURE TEST

The appliance and its individual shut off valve must be disconnected from the gas supply piping system during any pressure testing of that system at test pressures in excess of $1/2$ psi (**3.5 kpa**).

The appliance must be isolated from the gas supply piping system by closing its individual manual shut off valve during any pressure testing of the gas supply piping system at test pressures equal to or less than $1/2$ psi (**3.5 kpa**).

**READ THIS ENTIRE MANUAL
BEFORE OPERATING THIS UNIT
LIRE CE MANUEL EN ENTIER
AVANT D'UTILISER CET APPAREIL**

Table of Contents

1.0 Installation Instructions	9
1.1 General Information	10
1.2 Description of the Data Plate	10
1.3 Machine Drawings and Dimensions	11
1.4 Conversion and Adjustment Instructions	12
1.5 Adjustments and Verification for use with Natural Gas	12
1.6 Natural Gas Flow Table (Consumption)	13
1.6.1 Volumetric Method to Verify the Flame Setting, Mathematical	13
1.7 Orifice Diameters, Electronic Ignition Settings	14
1.8 Changing Gas Orifices	14
1.8.1 Changing the Gas Orifice - Gas Generators	14
1.8.2 Changing the Gas Orifice - Pipe Burner	14
1.9 Ignition Cycle	14
1.10.1 Adjusting the Ignition Electrode	14
1.10 Checking the Connected Gas Pressure (Nominal Pressure)	15
1.10.1 Adjusting the Ignition Electrode	15
1.11 Maintenance, Response to Technical Problems	16
1.12 Spit Drive Mechanism	17
1.12.1 Reasons for problems and solutions	18
1.13 Spit Drive Mechanism	19
1.14 Testing and Checking for Safety	20
1.15 Description of the Electrical Connection	20
1.16 Electrical Diagram	21
1.17 5.5 G Parts List	22
1.18 Exploded View Diagrams	24

1.0 Installation Instructions

- a. When installing these units, it is important to comply with the most recently established rules and regulations as deemed pertinent by the local and national electrical, gas, ventilation, sanitation, and fire codes. These units are classified by Underwriters Laboratories, Inc. as Gas-Fired Food Service Equipment in accordance with American National Standards Institute ANSI Z83.11b-1991, Gas Food Service Equipment - Ranges and Unit Boilers.
- b. Gas units must not be directly connected to a gas flue or exhaust. However, both electric and gas units may require operation in conjunction with a canopy type exhaust hood if deemed necessary by local authorities.
- c. The units must be installed in such a way that proper ventilation and heat exchange is assured. The room must be ventilated in accordance to the valid codes and regulations.
- d. The units are to be installed securely and horizontally. The units may be installed on combustible floors. The units must be installed with adjustable legs if placed on a combustible surface.
- e. The minimum clearance to the rear or side walls must be 13 inches. It is also important to insure that the bottom of the units is kept clear so that proper ventilation or air exchange can occur.
- f. Normally, the units will be sent to the operator already set up for the particular type of gas or electrical service available at their location. However, unless otherwise specified, the gas units will be set up for natural gas use (including an electrical cord for 120 V, 1 Phase, 60 Hz operation) and the electric units for 208 V, 3 Phase, 60 Hz electrical use. Before installing and using the units for the first time, it is important to make sure that the gas type and/or electrical power indicated on the data plate matches the type of gas and electrical power available in the location. Should this not be the case, it is imperative to change or convert the units to the needed types.
- g. The gas units must be fitted with the manual shut-off gas cock (valve) and pressure regulator supplied with the machine. This manual valve is needed to shut off the gas to the machine during maintenance work, repairs, and if the unit needs to be disconnected for any reason. The pressure regulator is needed to adjust the gas pressure entering the unit to ensure the proper operation of the unit. Electric units must be hard-wired or fitted with a power cord by a licensed electrician.
- i. Depending on local codes or if deemed necessary, a gas filter may also be required for gas units.

1.1 General Information

The Operating Instructions are to be given to the operator of the rotisserie. All unit operators are to be familiar with the functions of the rotisserie.

The Operating Instructions should be kept in a location close to the rotisserie. It should be easily recognizable and easily accessible.

The gas rotisseries can be used with both natural and LPG gases. The rotisseries can be converted or adjusted to any type of the locally distributed natural and LPG gases.

Electric units can be ordered to meet most electrical specifications.

It is recommended that a repair and maintenance contract be signed with the manufacturer's agent, distributor, or service agency.

1.2 Description of the Data Plate

Hickory Industries, Inc. <i>Commercial Cooking Appliances</i> North Bergen, NJ 07047	
Model: 5.5 G	Serial No. <input type="text"/>
Motor: 110 - 115 VAC, 50/60 HZ, 3 RPM	
Phase: <input type="text" value="1"/>	Gas: <input type="text" value="NAT"/>
Manifold Pressure: 5" Natural or 10-11" Propane	
BTU/H <input type="text" value="20,000"/>	Burners: 1
LISTED	Minimum Installation Clearance
	Sides: 13" Back: 13"
69D6	Maximum Lamp Wattage: 40 Watts

Hickory Industries, Inc. <i>Commercial Cooking Appliances</i> North Bergen, NJ 07047	
Model: 5.5 G	Serial No. <input type="text"/>
Motor: 110 - 115 VAC, 50/60 HZ, 3 RPM	
Phase: <input type="text" value="1"/>	Gas: <input type="text" value="LPG"/>
Manifold Pressure: 5" Natural or 10-11" Propane	
BTU/H <input type="text" value="17,000"/>	Burners: 1
LISTED	Minimum Installation Clearance
	Sides: 13" Back: 13"
69D6	Maximum Lamp Wattage: 40 Watts

WARNING!

This unit must be installed and connected in accordance to the latest regulations and can only be operated in conjunction with forced ventilation or exhaust hood.

This unit has been designed for professional use only and may only be installed or repaired by licensed service agencies!

Before installing or using this equipment, read these instructions!

1.3 Machine Drawings and Dimensions

The following drawing of the Front View, Side View, and Top View indicate where the dimensions are taken and should be used to plan the installation of the units.

N/ 5.5 G

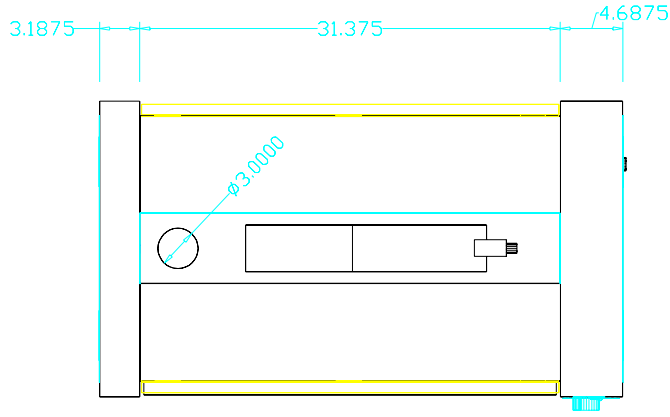

Top View

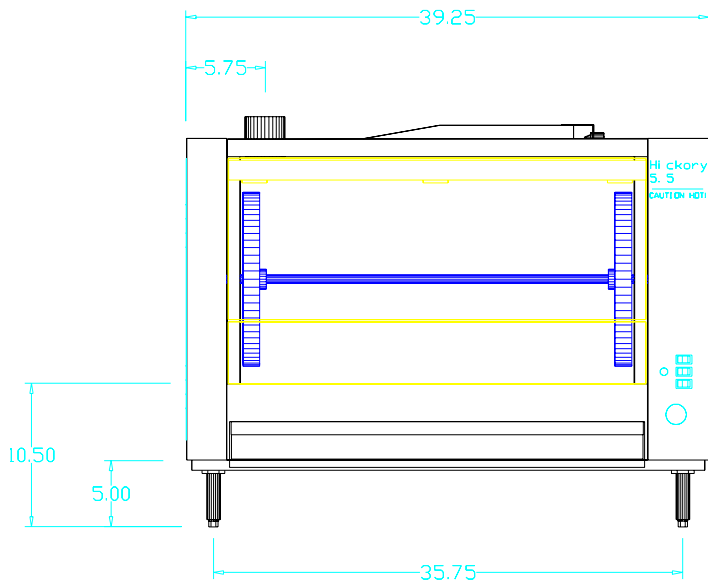

Front View

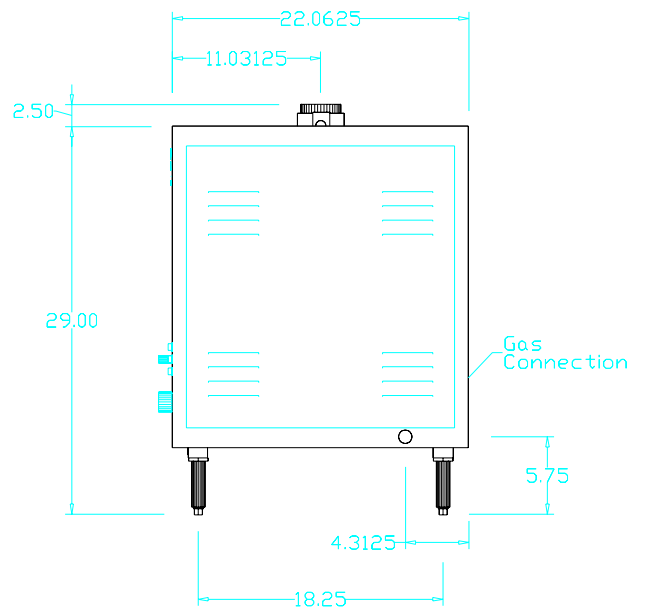

Right Side View

N/ 5.5 G	inches	mm
Height	31.5"	800
Width	39.25"	997
Depth	22"	560

* Includes Gas Connection Attachments

1.4 Gas Conversion and Adjustment Instructions

Before converting or adjusting the machine to another type of gas, it is imperative that the manual gas cock be turned to the "off" position. The electrical power to the machines should also be turned off. When converting the gas generators for use from one type of gas use to another, the gas orifice (or injector) must be changed according to the table on page 8. In addition, the spring in the pressure regulator supplied with the unit must be changed so that it can operate at other gas pressures. Springs for the regulator can be ordered from Hickory Industries.

1.5 Verification for use with Natural Gas

The flame setting for the gas generator can be confirmed by using the volumetric method in conjunction with the main gas meter. The burner has an independent solenoid gas valve. The valve is controlled by an independent Gaslite spark ignition module. The amount of gas flowing through the valve can not be adjusted manually; there is only an "on" or "off" position.

To carry out this verification procedure, it is necessary to obtain the heating value (BTU/ft³) of the local gas from the local gas company.

A variation in the heating value of the local gas from that on the table (1.6) will result in a variation of the power output of the unit!

If the measured gas volume does not correspond to the values in the following table (1.6), the items which should be checked are:

- A. The incoming (connected) gas pressure while the burners and all other appliances in the location are operational.
- B. If the gas pressure is correct, it must be verified that the proper size gas orifices are in place (see page 8).

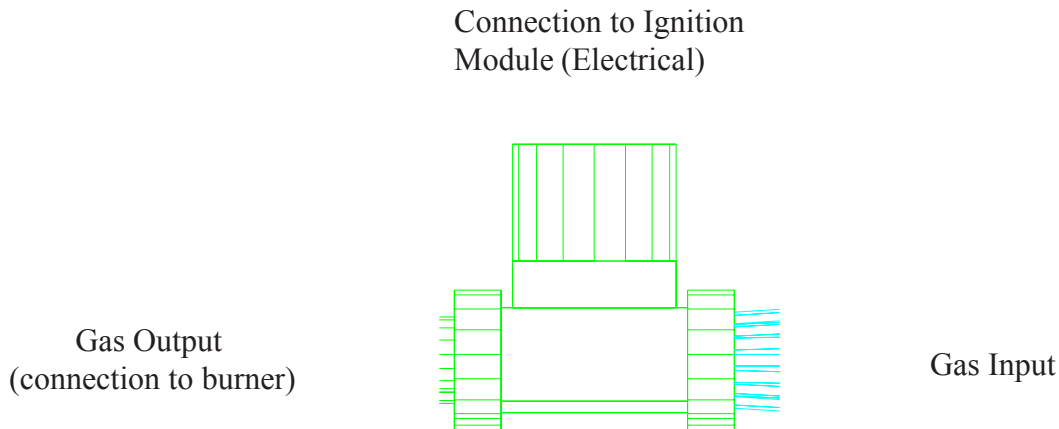

Solenoid Valve

1.7 Natural Gas Flow Table

		Gas Flow - in ft ³ /hr
Gas	Heating Value in	20,000 BTU - Natural
	BTU/ft ³	17,000 BTU - LPG
		High Flame Setting
Natural	1040	19.23
Propane	2480	6.85
Butane	3215	5.28

1.7.1 Volumetric Method to Verify the Flame Setting, Mathematical

WARNING! No other gas equipment can be in operation during this procedure.

Calculation of flow rate V in ft³/hour

$$V = \frac{FP}{H_i}$$

V = Flow rate in ft³/minute

FP = High Flame Power setting in BTU/hr

H_i = Heating value in BTU/ft³

Thus, for natural gas:

$$V = \frac{20,000 \text{ BTU/hr}}{1040 \text{ BTU/ft}^3} = 19.23 \text{ ft}^3/\text{hr} = 0.32 \text{ ft}^3/\text{min.}$$

$$V = 0.32 \text{ ft}^3/\text{min.}$$

This is the natural gas needed in 1 hour by a N/5.5 G (1 burner) at full power.

The time and the flow measurements should be taken at the gas (flow) meter with a chronometer (stop watch).

To run the test, open the manual gas cock valve, start up the unit according to the start-up instructions.

Allow the unit to pre-heat (burn) for 10 to 15 minutes. Verify that the flow rate is calibrated to the appropriate flow rate indicated in the table.

1.8 Orifice Diameters, Electrode Gap Settings, and Air Intake Settings
Type N/ 5.5 G

Gas / Pressure	Orifice Size	Electronic Ignition	
inches W.C.	Ø in drill size	Electrode Gap	
Natural / 5.5"	#46	1/8" Between rods 1/8" Between rods and Burner surface	
Propane / 11"	#55	1/8" Between rods 1/8" Between rods and Burner surface	
Butane / 11"	#55	1/8" Between rods 1/8" Between rods and Burner surface	

1.9 Changing Gas Orifices on the Gas Generators

The N/5.5 Gas unit has one infra-red gas generators. These generators use **ceramic** radiating plates.

The burner orifice can be removed and replaced using a 7/16" wrench. The orifice must be sealed and tightly in place.

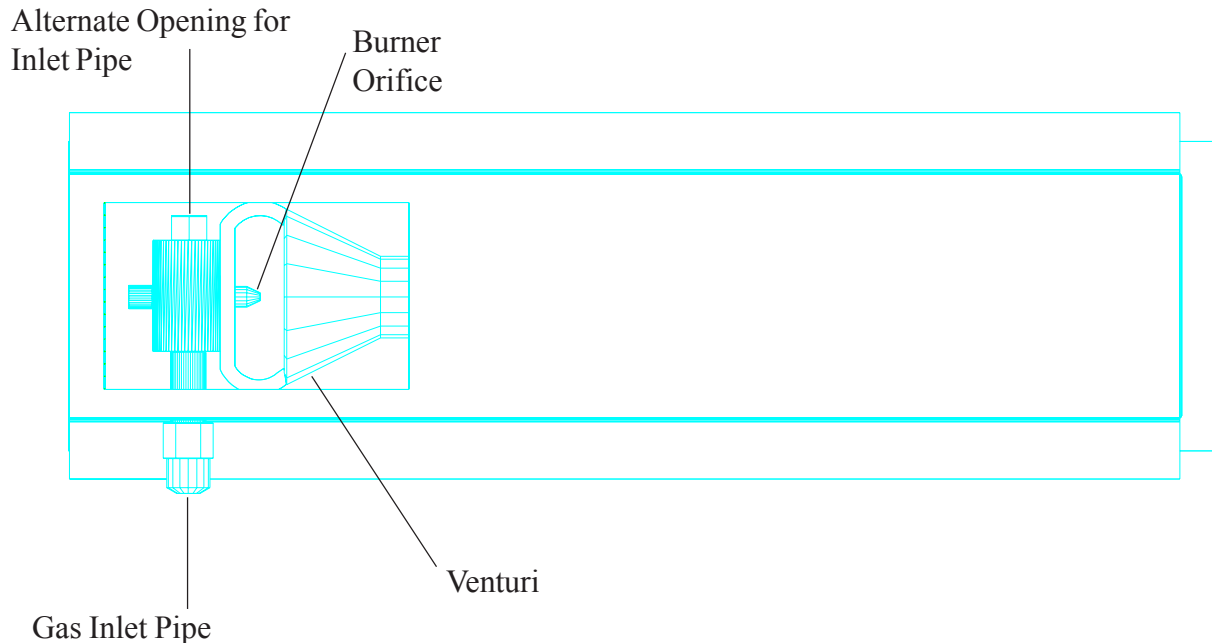

Top View Gas Generator

1.10 Ignition Cycle

In order to start the cooking cycle, the burners must be ignited. The ignition cycle will start only when the following procedure is followed:

- a. The "HEAT" switch is turned to "on".
- b. A cooking temperature must be set on the thermostat (i.e. 450°F).
- c. The cooking timer must be activated (see Operating Instructions).

Once these steps are completed, the unit will call for heat and the ignition cycle will be activated. The ignition system will cause sparking on the ignition electrode. Once the burner is lit by the spark, the flame of the burner will heat the sensing prong on the ignition electrode sending a signal back to the ignition module. This signal indicates that a spark is no longer needed and that the solenoid gas valve must stay open. When the cooking temperature is reached, as sensed by the thermocouple attached to the thermostat, the electrical power to the ignition modules will be cut off, shutting down the ignition module and the burners. When the temperature drops below the set point, electrical power is sent to the ignition system once again, thus starting the ignition cycle all over. The system will cycle on and off as needed to maintain the set cooking point.

The ignition modules will attempt to ignite the burner three times. If the burners fail to light after three tries, the module will lock-out, shutting down all gas flow and further sparking.

In order to start the ignition cycle after a lock-out, the heat switches and individual burner switches must be turned "off" and "on" again. This may have to be done several times when starting up the unit for the first time due to air in the gas lines.

1.10.1 Adjusting the Ignition Electrode

The ignition electrodes are adjusted for an optimum ignition cycle before the unit leaves the factory. If for some reason the electrodes need adjusting (i.e. if one takes a hit with a spit), it can be done as follows.

1. To reach the ignition electrode, open the front glass doors and remove all spits.
2. The electrode is attached to the main body of the machine with an 8/32" screw and nut. It is important that this screw make solid metal to metal contact between the electrode casing and the body of the rotisserie. This metal to metal contact is what acts as a grounding conductor for the grounding prong on the ignition electrode.
3. During the ignition process, a solid blue spark should travel between the tip of the two electrode prongs.
4. Make sure that the distances between the prongs and the surface of the burner are about 1/8".

Ignition Wire Connection

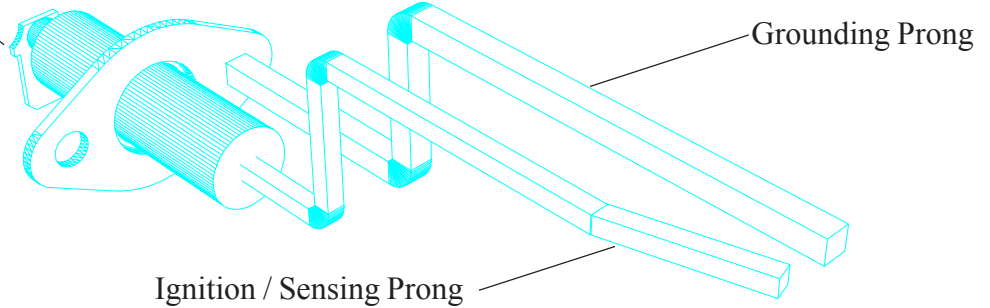

Ignition Electrode

5. If the distances between the prongs and/or the burner surface are too great, the unit may spark but not ignite the burner.
6. When adjusting the prongs, make sure to support the base of the prong with one pair of pliers and adjust the tip of the prong with another pair. This will prevent breakage of the ceramic casing of the ignition/sensing prong. If the ceramic casing does break, the electrode will have to be replaced.

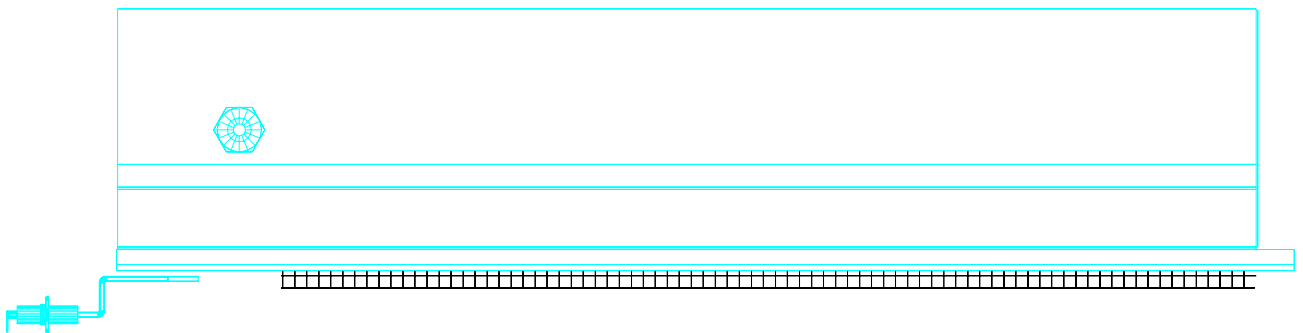

Ignition Electrode Position

1.11 Checking the Connected Gas Pressure (Nominal Pressure)

Close the gas cock where the gas line is connected to the machine and attach a manometer to the tap (allen screw) on the gas cock. With the manometer connected, open the gas cock and ignite the burner. **Along with all other gas appliances at the location in operation, measure the gas pressure.**

This ideal operating pressure should be 5.5" W.C. for natural gas and 11" W.C. for LPG.

If the pressure is too high and can not be adjusted downward, check to see if the proper adjusting spring is in the regulator. If this is correct, the regulator membrane may have been ruptured by excessive gas pressure and may have to be replaced. Do not operate the rotisserie if the gas pressure exceeds the ideal values.

If the operating pressure is below 5.5 " W.C. for natural gas or below 11 " W.C. for LPG, the unit should not be operated. The pressure should be adjusted to the ideal setting using the pressure regulating screw on the pressure regulator.

If the pressure is too low and can not be adjusted upward, also check the regulator. If this is operating properly, verify the pressure coming out of the main gas meter. Another typical source of this pressure problem is that the gas line (pipe) diameter leading up to the unit is too small. If the gas line is under-sized, the appropriate pressure may not be reached. Do not operate the unit if the pressure falls below the ideal values.

If the measured pressure is still below the ideal range and it is not possible to resolve the problem, the local gas company or gas supplier should be contacted so that they can resolve the problem.

After the pressure has been set, close the gas cock once again, remove the manometer, seal the gas tap, and then re-open the gas cock.

WARNING: After an installation, repairs, or maintenance, make sure that there are no gas leaks anywhere in the gas lines or system.

1.12 Maintenance, response to technical problems.

Should a technical problem arise for any reason, shut off the machine and call for technical service.

A routine maintenance should be carried out at least once a year. Contact your local, certified service company for maintenance.

1.12.1 Reasons for problems and solutions

Problem	Cause	Solution
Electrode does not spark.	<ul style="list-style-type: none"> a. Rotisserie not "on". b. Electrical system not grounded properly. c. Electrode tips too far apart. d. Electrode tips are dirty. e. Electrode not grounded. f. Ignition wire loose. g. Ignition wire not properly insulated. h. Ignition module faulty. 	<ul style="list-style-type: none"> a. Make sure that the HEAT switch is on. Thermostat must be set (i.e. 550°F) and the cooking timer must be operational (cook cycle). b. Make sure that the three pronged plug supplied with the unit is being used. Make sure that the rotisserie is properly grounded. c. Adjust electrode tips to 1/8" apart. d. If the machine is used, fat may have carbonized on the electrode tips or rust may have appeared. This prevents proper sparking. Sand and clean metal rods. e. Make sure that electrode is properly fastened and makes solid contact with the rotisserie body. f. Make sure that the ignition wire is properly fastened to the ignition module and to the electrode. g. Check the ignition wire for breaches which may cause sparking to occur between the cable and the body of rotisserie. Insulate cable at breach. h. Check electrical input to module. Module may need to be replaced.
Electrode sparks, flame does not light.	<ul style="list-style-type: none"> a. Check all gas flow. b. Check polarity on the electrical connections. c. Flame is too weak. Not enough gas flow. 	<ul style="list-style-type: none"> a. Turn all manual gas valves to "on". Make sure the solenoid valve opens. b. Make sure that the hot, neutral, and ground leads are properly matched up. If neutral and hot are switched, the "flame on" signal will not reach ignition module, locking out gas. c. Check the operating gas pressure. If this is correct, check gas line and orifice for dirt or obstructions.
Burner ignites for 5 to 10 second and then goes off, especially in the morning when cold.	<ul style="list-style-type: none"> a. Electrode tips are too far from burner. b. High humidity environment, such as caused by leaving water in drip pan overnight. c. Unit not properly adjusted to new conditions. 	<ul style="list-style-type: none"> a. Adjust the tips of the electrode rods so that they are about 1/8" from the burner surface. b. Switch exhaust hood to on before igniting the unit. Open front door of the unit to allow air flow. b. Re-adjust ignition prongs.

1.13 Spit Drive Mechanism

This unit is equipped with a planetary motion spit drive system. This means that each spit is turning upon its axis at the same time that they turn about the center shaft. When the motor switch is turned to on, the disks and the spits will begin to turn. Insure that the mechanism turns smoothly when testing the unit.

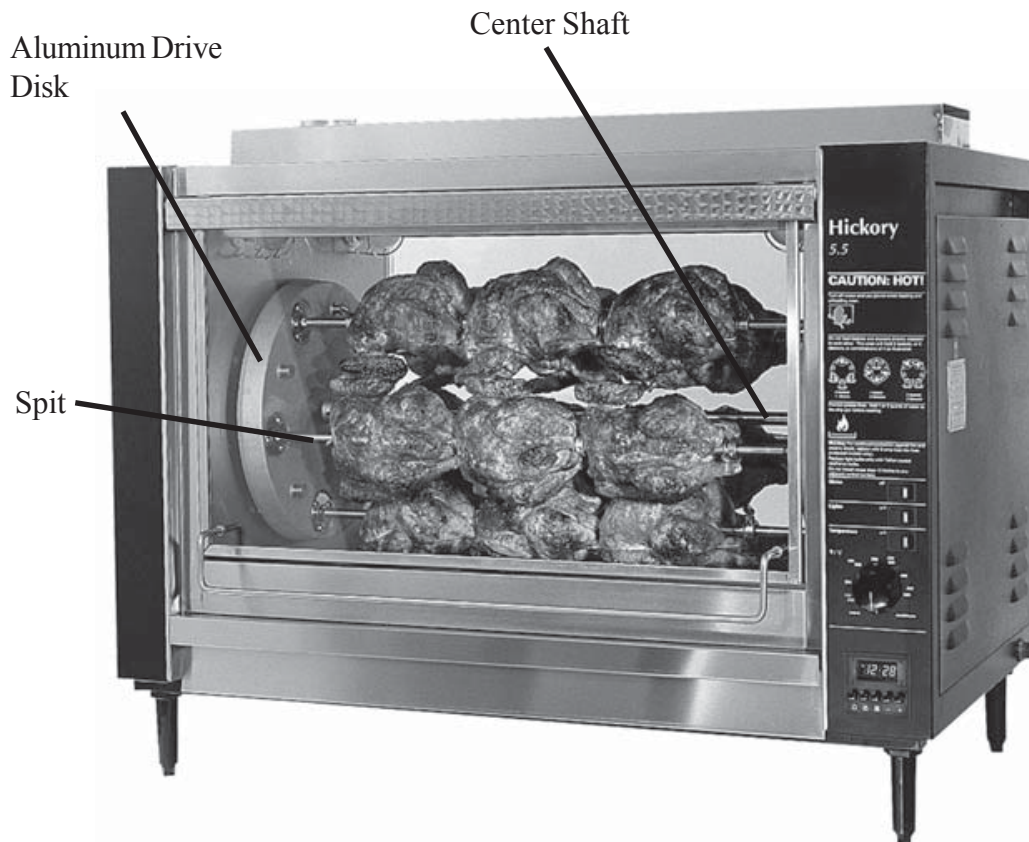

Before cooking, it is imperative that the center shaft be covered and protected with aluminum foil. This will prevent fats from carbonizing on the shaft, making the removal of the aluminum disks much easier in the future. If the shaft is not protected, it may eventually be impossible to remove the disks should there be a problem in the spit drive mechanism.

The driven and the stationary drive gears are located behind the aluminum drive disk. These can be viewed by taking out the removable aluminum disks (there are two removable panels). The driven gears and the stationary gear should be viewed once a week to check for fat or carbonization build-up. Any fat or dirt should be cleaned off since a build-up will eventually damage the drive system.

NOTE: If fat or carbon have built up on the center shaft, it may not be possible to move the aluminum disks!

With the disks away from the sides, all components of the drive mechanism should be thoroughly cleaned. This will guarantee that the drive mechanism works smoothly.

Even though the aluminum disks protect the gears, fat will eventually manage to build up on the gears. If this fat is not cleaned, it will eventually carbonize. When the carbon build-up is serious enough, the drive mechanism will jam and it will need to be replaced.

When replacing the disks, a slight dab of FDA (food safe) approved grease should be added to all gears.

Finally, when inserting spits, make sure to stop the motor! This unit is supplied with a motor switch which will stop the drive mechanism, allowing the operator to insert the spits easily. If spits are inserted without stopping the motor, there is a chance that the drive system will be jammed and cause severe damage.

1.14 Testing or checking for safety

After a conversion, a new installation, or after a repair, it is important that the unit be tested to insure that it operates properly. This should include the following:

Test the gas system for gas leaks.

Check that the unit has enough clearance behind and to the sides.

Check that enough primary and secondary air is available (bright orange gas generator).

Check for potentially flammable objects or potential flammability problems.

Check for proper ventilation and exhaust.

Check for proper room ventilation.

1.15 Description of the Electrical Connection

The electrical connections are to be made in accordance to local and national codes.

All gas machines operate with 120 Volt, single phase, 60 Hz. A NEMA 5-15P plug is supplied with the units.

All pertinent electrical information can be taken from the electrical diagram.

NOTE: Proper polarity in the electrical system is needed for proper operation of the gas system!

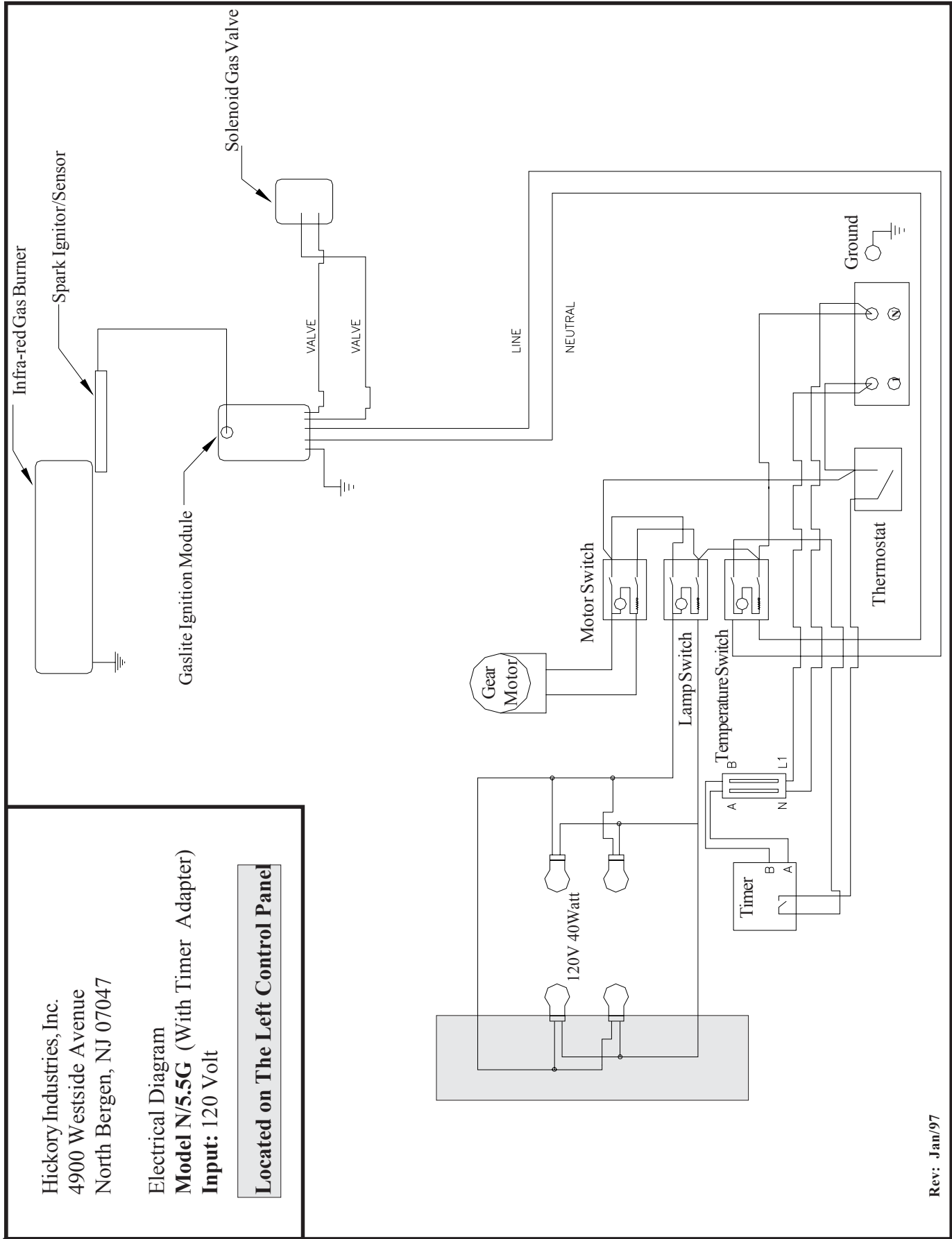

Hickory Industries, Inc.
 4900 Westside Avenue
 North Bergen, NJ 07047

Electrical Diagram
Model N/5.5G (With Timer Adapter)
Input: 120 Volt

Located on The Left Control Panel

Rev: Jan/97

1.17 Parts List for 5.5 G

Item	Qty.	Description	Material	Length	Size	Manufacturer
553	1	Shaft 5/8 (Removable Drums - Center)	SS		5/8"	Hickory
554	1	Shaft Locking Slide	SS			Hickory
519	1	Drive Bearing Holder (Left - with brass bearing)	Steel (Chromed)			Hickory
520	1	Drive Bearing Holder (Right - with teflon bearing)	Steel (Chromed)			Hickory
	1	Brass Shaft Bearing	Brass			Hickory
566	1	Teflon Shaft Bearing	Teflon			Hickory
501	1	Aluminum Disk Drive (Bare)	Cast Aluminum			Hickory
502	1	Aluminum Disk Slave (Bare)	Cast Aluminum			Hickory
503	1	Alum. Disk Drv. (Complete w/ Spit Driven Gears)				Hickory
504	1	Alum. Disk Slave (Complete w/ Spit Supports)				Hickory
514	1	Disk Retaining Pin	Steel	1-1/2"	5/32"	Hickory
564	5	Teflon Spacers - 1/4" round				Hickory
505		Aluminum Disk Teflon Coating				Hickory
561	5	Spit Driven Gear Assembly	Steel (Chromed)			Hickory
555	5	Snap Ring (Gears)	Steel			Hickory
559	5	Spit Driven Gear Bearing Holder	Steel (Chromed)			Hickory
560	5	Spit Driven Gear	Steel (Chromed)			Hickory
565	5	Teflon Spit Driven Gear Bearing			1/4"	Hickory
563	1	Stationary Gear	Steel			Hickory
562	5	Spit Support	Steel (Chromed)			Hickory
510	1	Chain (Roller - 5.5)	Steel			Hickory
511	1	Chain Link (Roller - 5.5)	Steel			Hickory
521	1	Drive Sprocket - Roller Chain	Steel			Hickory
522	1	Driven Sprocket - Roller Chain	Steel			Hickory
512	1	Chain Tensioner	Steel			Hickory
509	1	Buss Fuse 0.5 Amp				Buss
527	1	Fuse Holder 0.5 Amp				
536	1	Ignitor Electronic Ignition				Channel
	1	Ignition Wire				
537	1	Ignitor Module (Gaslite)				Channel
538	4	Lamp Cover	Steel (Chromed)			Hickory
541	3	Micro Switch & Toggle				Marquardt
567	1	Thermostat 200-550				
568	1	Thermostat Knob				
569	1	Timer (without Adapter)				Eaton
569	1	Adapter (for Timer)				Eaton
542	1	Motor Gear - 120V				Bodine
539	1	Lamp, 120 V				Hickory
540	4	Lamp Socket	Ceramic			Leviton
120	1	Drip Pan (5.5)	SS			Hickory
121	1	Drip Pan Plug	Brass			Hickory
122	1	Drip Pan Receptacle	Brass			Hickory

1.17 Parts List for 5.5 G (Contd.)

Item	Qty.	Description	Material	Length	Size	Manufacturer
546	1	Pressure Regulator (Connection) RV53	Alum.		1/2"	Maxitrol
	1	Spring for Pressure Regulator				Maxitrol
528	1	Gas Cock	Steel		1/2"	Jomar
	1	Nipple	Steel		1/2"	Hickory
	1	Elbow (90°)	Steel		1/2"	Hickory
	1	Pipe	Steel	6"	1/2"	Hickory
529	1	Basotrol Solenoid Gas Valve			1/2"	Basotrol
	1	Pipe	Steel	13.5"	1/2"	Hickory
	1	Elbow (90°) St.	Steel		1/2"	Hickory
530a	1	Gas Burner with Ceramics	Ceramic			Hickory
543	1	Orifice (Blank)	Brass			Hickory
513	2	Glass Hinge	SS			Hickory
515	2	Door Bearing Brass	Brass			Hickory
516	1	Door Handle (Metal)	Steel			Hickory
518	1	Door Spring (Mechanical)	Steel			Hickory
545	1	Pneumatic Spring				
532	1	Glass Tempered Large (Door)	Glass		28.94" x 16.5"	Hickory
533	1	Glass Tempered (Rear)	Glass		28.94" x 12"	Hickory
534	1	Glass Tempered (Rear - Small)	Glass		28.94" x 4.5"	Hickory
526	4	Feet Adjustable Plastic	Plastic			Hickory
556	5	Spit Complete	SS			Hickory
185	5/Spit	Skewer Double	SS			Hickory
186	5/Spit	Skewer Single	SS			Hickory
219	1/Skw.	Thumb Screw	Steel			Hickory
439a		Angle (V) Spits	Steel (Chromed)			Hickory
508		Basket Spits	Steel (Chromed)			Hickory
557	1	Spit Turkey Center only	SS			Hickory
225	2	Turkey Skewers Single	SS			Hickory
506	5	Basket Hanging	Steel (Chromed)			Hickory
507	5	Basket Bearing Brass	Brass			Hickory
123	1	Electrical Grounding Cap			Hickory	
		Electrical Wire			Janor Wire	
	1	Connection Cable			TIP Products	
104	1	Contact Section 242 (terminal)			Buchanan	
105	1	Contact Section 250 (end-piece)			Buchanan	

*All components are inventories and sold through Hickory Industries and their distributors and dealers.

1.18 Exploded View Diagrams

