

Hickory Rotisseries

Models: N/3G, N/5G, N/7G, N/9G, & N/14G

Machine Type	N / 5 G, N / 7 G
Total Power Rating	120,000 BTU
Burner / Spits	3 Burners with 5 or 7 Spits
Gas Categoric	Natural Gas, LPG
Fittings	3 Regulated Burners
Ignition	3 Gas Pilot Lights
Delivery Date:	Final Inspection:

Machine Type	N / 9 G
Total Power Rating	160,000 BTU
Burner / Spits	4 Burners with 9 Spits
Gas Categoric	Natural Gas, LPG
Fittings	4 Regulated Burners
Ignition	4 Gas Pilot Lights
Delivery Date:	Final Inspection:

(LEFT BLANK INTENTIONALLY)

Please copy, cutout and place in a prominent location.

What To Do If You Smell A Gas Odor

Natural gas is lighter than air, and it has a very high ignition temperature. For your protection, The Gas Company adds a distinctive odor to natural gas, so leaks are easily detected.

If you smell a Natural gas or a Propane gas odor:

- **DON'T panic.**
- **DON'T light a match, candle or cigarette.**
- **DON'T turn electrical appliances or lights on or off.**

For safety, a shut-off valve was installed on this appliance. If a leak occurs at this appliance, the valve will permit you to turn off the gas at the appliance rather than shutting off all gas service at the meter.

SHUT off the appliance shut-off valve.



From a safe location, call your local Gas Company 24 hours a day, seven days a week; or call **9-1-1**.

S'il vous plaît copier, découper et placer dans un endroit bien en vue.

Que faire si vous sentez une odeur de gaz

Le gaz naturel est plus léger que l'air , et il a une très haute température d'allumage . Pour votre protection, La Compagnie du Gaz ajoute une odeur caractéristique du gaz naturel , de sorte que les fuites sont facilement détectées.

Si vous sentez un gaz naturel ou une odeur de gaz propane :

- **Ne paniquez pas.**
- **NE PAS allumer une allumette , bougie ou cigarette.**
- **NE PAS tourner les appareils électriques ou les lumières ou désactiver.**

Pour plus de sécurité , une soupape d'arrêt a été installé sur l'appareil. Si une fuite se produit à cet appareil , la vanne vous permettra de couper le gaz à l'appareil plutôt que couper tous les services de gaz au compteur.

Fermez le robinet d'arrêt appareil.

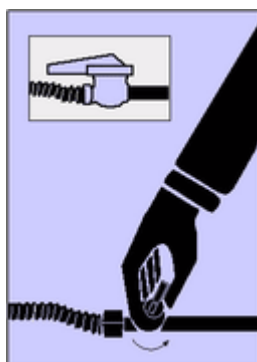

D'un endroit sûr , appelez votre compagnie de gaz locale 24 heures par jour , sept jours par semaine ; ou composez le 9-1-1.

FOR YOUR SAFETY

Do Not Store or use gasoline or other flammable vapors or liquids in the vicinity of this or any other appliance.

WARNING: Improper installation, adjustment, alteration, service or maintenance can cause property damage, injury or death. Read the Installation, operating and maintenance instructions thoroughly before installing or servicing this equipment.

POUR VOTRE SÉCURITÉ

Ne pas entreposer ou utiliser de l'essence ou d'autres vapeurs ou liquides inflammables au voisinage de cet appareil ou de tout autre appareil.

AVERTISSEMENT: Une mauvaise installation , le réglage , la modification, un service ou d'entretien peut causer des dommages matériels, des blessures ou la mort. Lire l' installation , l'exploitation et la maintenance instructions avant l'installation ou l'entretien de cet équipement.



As a safety precaution, disconnect the power supply to the appliance before cleaning or servicing this appliance.



Par mesure de sécurité, débrancher l'alimentation électrique l'appareil avant le nettoyage ou l'entretien de cet appareil.

Instruction Plate:

Before lighting this piece of equipment, ensure that the ventilation hood is turned on

1. Set pilot valve with screwdriver to provide 1/2" flame by turning pilot valve counterclockwise **2.** Light corresponding pilot light with a match or long match **3.** After pilot lights have been lit, turn desired valve "ON".

NOTICE: In order to be able to service this appliance, it must be installed with the casters supplied, a connector complying with **ANSI Z21.69** or **CAN/CGA-6.16** and a quick-disconnect device complying with **ANSI Z21.41** or **CSA-6.9**. It must also be installed with restraining means to guard against transmission of strain to the connector as specified in the appliance manufacturer's instructions.

AVIS: Afin d'être en mesure de réparer cet appareil, il doit être installé avec les roulettes fournis, un connecteur conforme à la norme **ANSI Z21.69** ou **CAN / CGA- 6.16** et un dispositif de déconnexion rapide conforme à la norme **ANSI Z21.41** ou **CSA- 6.9**. Il doit également être installé avec moyens de retenue pour se prémunir contre la transmission de la souche au connecteur tel que spécifié dans les instructions du fabricant de l'appareil.

For Natural Gas: Burners are equipped with orifice spud drilled with No.30 drill size.

For LP Gas: Burners are equipped with orifice spud drilled with No. 49 drill size.

INSTALLATION GUIDELINES / CONSIGNES D'INSTALLATION

GAS / GAZ

Gas installation must conform with local codes, or in the absence of local codes, with the **National Fuel Gas Code, ANSI 2223.1 /NFPA 54**, or the **Natural Gas and Propane Installation Code, CSA B749.1**

installation de gaz doit être conforme aux codes locaux , ou en l'absence de codes locaux, avec le **Code National Fuel Gas , ANSI 2223,1 / NFPA 54 , ou le gaz naturel et propane Code d'installation , CSA B749.1**

ELECTRICAL INSTALLATION / INSTALLATION ÉLECTRIQUE

This appliance, when installed, must be electrically grounded in accordance with local codes, or in the absence of local codes, with the **National Electrical Code, ANSI/NFPA 70**, or the **Canadian Electrical Code, CSA C22.2**, as applicable. For your convenience, this appliance has been wired with a NEMA 5-15 cord and plug and should be plugged in to a corresponding NEMA 5-15 receptacle. The grounding prong **SHOULD NOT BE CUT. Cutting the grounding prong will void the manufacturers warranty**

Cet appareil , lorsqu'il est installé , doit être mis à la terre conformément aux codes locaux , ou en l'absence de codes locaux, avec le **National Electrical Code , ANSI / NFPA 70 , ou au Code canadien de l'électricité , CSA C22.2** , selon le cas . Pour votre commodité, cet appareil a été câblé avec un cordon NEMA 5-15 et branchez et doit être branché à un correspondant NEMA 5-15 réceptacle. La mise à la terre doit pas être coupé . **Couper la broche de terre annulera la garantie du fabricant**

PRESSURE TEST / TEST DE PRESSION

The appliance and its individual shut off valve must be disconnected from the gas supply piping system during any pressure testing of that system at test pressures in excess of $1/2$ psi (**3.5 kpa**).

The appliance must be isolated from the gas supply piping system by closing its individual manual shut off valve during any pressure testing of the gas supply piping system at test pressures equal to or less than $1/2$ psi (**3.5 kpa**).

L'appareil et son robinet d'arrêt doit être déconnecté du système de tuyauterie d'alimentation en gaz pendant les essais de pression de ce système à des pressions de test supérieures à $1/2$ psi (**3,5 kpa**) .

L'appareil doit être isolé du système de tuyauterie d'alimentation en gaz en fermant son manuel individuel robinet d'arrêt pendant tout test de pression du système de tuyauterie d'alimentation en gaz à des pressions d'essai moins de $1/2$ psi (3,5 kpa) égale ou .

Table of Contents

*KEEP THIS MANUAL FOR FUTURE REFERENCE
(CONSERVER CE MANUEL POUR FUTURE RÉFÉRENCE)*

1.0 Installation Instructions	9
1.1 General Information	10
1.2 Description of the Data Plate	10
1.3 Machine Drawings and Dimensions	12
1.4 Machine Dimensions	13
1.5 Conversion and Adjustment Instructions	13
1.6 Adjustments and Verification for use with Natural Gas	13
1.7 Natural Gas Flow Table (Consumption)	14
1.7.1 Volumetric Method to Verify the High Flame Setting, Mathematical	14
1.8 Orifice Diameters, Primary Air Intake Settings, and Pressure Regulators	15
1.9 Changing Gas Orifices	16
1.9.1 Changing the Main Gas Orifice	16
1.9.2 Changing the Pilot Gas Orifice	17
1.10 Checking the Connected Gas Pressure (Nominal Pressure)	18
1.11 Maintenance, Response to Technical Problems, and Solutions	18
1.12 Testing or Checking for Safety	19
1.13 For Proper Operation	20
1.14 Description of the Electrical Connection	21
1.15 Electrical Diagram	21
1.16 Parts List for N/ 5G and N/ 7G with Diagrams	22
1.17 Parts List for N/ 9 G	27
2.0 Operating Instructions	30
2.1 Start up	30
2.2 Shut down	30
2.3 Working with the Rotisserie	32
2.4 Cooking Times	33
2.5 Daily Cleaning	34
2.6 Cleaning Procedures	35
2.7 Maintenance Procedures	36

INTENDED FOR OTHER THAN HOUSEHOLD USE
OVEN MUST BE KEPT CLEAR OF COMBUSTIBLES AT ALL TIMES

1.0 Installation Instructions

- a. When installing these units, it is important to comply with the most recently established rules and regulations as deemed pertinent by the local and national electrical, gas, ventilation, sanitation, and fire codes. These units are classified by Underwriters Laboratories, Inc. as Gas-Fired Food Service Equipment in accordance with American National Standards Institute ANSI Z83.11b-1991, Gas Food Service Equipment - Ranges and Unit Boilers.
- b. These gas units must not be directly connected to a gas flue or exhaust. However, the units may only be operated in conjunction with a canopy type exhaust hood or a direct flue vent.
- c. The room where the units are being installed must be ventilated in accordance to the valid codes and regulations.
- d. The units are to be installed securely and horizontally. The units may be installed on combustible floors. The units may be installed on adjustable legs or on casters (wheels).
- e. The minimum clearance to the rear or side walls must be 6 inches. The minimum clearance between the hinged gas pipe cover on the spit handle side of the machine and the side wall should be 24 inches for a sliding door and 10 inches for a hinged door. It is also important to insure that the bottom of the units is kept clear so that proper ventilation or air exchange can occur.
- f. Normally, the units will be sent to the operator already set up for the particular type of gas available at their location. However, unless otherwise specified, the units will be set up for natural gas use. Before installing and using the units for the first time, it is important to make sure that the gas type indicated on the data plate matches the type of gas available in the location. Should this not be the case, it is imperative to change or convert the units to the needed gas type.
- g. The units must be fitted with the manual shut-off gas cock (valve) supplied with the machine. This manual valve is needed to shut off the gas to the machine during maintenance work, repairs, and if the unit needs to be disconnected for any reason.
- h. A gas regulator is also supplied with the machine. This component is needed so that the appropriate gas pressure can be set and insure an optimum operation of the unit.
- i. Depending on local codes or if deemed necessary, a gas filter may also be required.

1.1 General Information

The Operating Instructions are to be given to the operator of the rotisserie. All unit operators are to be familiar with the functions of the rotisserie.

The Operating Instructions should be kept in a location close to the rotisserie. It should be easily recognizable and easily accessible.

These rotisseries can be used with both natural and LPG gases. The rotisseries can be converted or adjusted to any type of the locally distributed natural and LPG gases.

It is recommended that a repair and maintenance contract be signed with the manufacturer's agent, distributor, or service agency.

1.2 Description of the Data Plate

HICKORY INDUSTRIES, INC.	
COMMERCIAL COOKING APPLIANCES	
NORTH BERGEN, NJ 07047	
MODEL	<input type="text" value="N/7G"/> SERIAL NO. <input type="text"/>
MOTOR: 110 - 115 VOLTS 60 CYCLE AC CURRENT 1/3 HP SINGLE PHASE 1725 RPM	
BURNERS	<input type="text" value="3"/>
LISTED  69D6	GAS INPUT PER BURNER <input type="text" value="40,000"/> BTU/H
	MANIFOLD PRESSURE <input type="text" value="5.5"/>
	TYPE OF GAS <input type="text" value="NAT"/>
	MFG. DATE <input type="text"/>
MINIMUM INSTALLATION CLEARANCE SIDE: 6 INCHES BACK: 6 INCHES MAXIMUM LAMP WATTAGE: 150 WATTS FOR INSTALLATION ON A COMBUSTIBLE FLOOR <small>Gas-fired Food Service Equipment Classified by Underwriters Laboratories Inc. In accordance with American National Standards Institute ANSI Z 83.11b-1991, Gas Food Service Equipment-Ranges and Unit Boilers</small>	

HICKORY INDUSTRIES, INC.	
COMMERCIAL COOKING APPLIANCES	
NORTH BERGEN, NJ 07047	
MODEL	<input type="text" value="N/9G"/> SERIAL NO. <input type="text"/>
MOTOR: 110 - 115 VOLTS 60 CYCLE AC CURRENT 1/3 HP SINGLE PHASE 1725 RPM	
BURNERS	<input type="text" value="4"/>
LISTED  69D6	GAS INPUT PER BURNER <input type="text" value="40,000"/> BTU/H
	MANIFOLD PRESSURE <input type="text" value="5.5"/>
	TYPE OF GAS <input type="text" value="NAT"/>
	MFG. DATE <input type="text"/>
MINIMUM INSTALLATION CLEARANCE SIDE: 6 INCHES BACK: 6 INCHES MAXIMUM LAMP WATTAGE: 150 WATTS FOR INSTALLATION ON A COMBUSTIBLE FLOOR <small>Gas-fired Food Service Equipment Classified by Underwriters Laboratories Inc. In accordance with American National Standards Institute ANSI Z 83.11b-1991, Gas Food Service Equipment-Ranges and Unit Boilers</small>	

WARNING!

This unit must be installed and connected in accordance to the latest regulations and can only be operated in conjunction with forced ventilation or exhaust hood.

**This unit has been designed for professional use only and may only be installed or repaired by licensed service agencies!
Before installing or using this equipment, read these instructions!**

ATTENTION!

Cet appareil doit être installé et branché conformément aux dernières réglementations et ne peut être utilisé en conjonction avec une ventilation forcée ou une hotte .

**Cet appareil a été conçu pour un usage professionnel et ne peut être installé ou réparé par les organismes de services autorisés !
Avant d'installer ou d'utiliser cet appareil, lisez ces instructions!**

1.3 Machine Drawings and Dimensions

The following drawing of the Front View, Side View, and Top View indicate where the dimensions are taken and should be used to plan the installation of the units.

N / 7 G

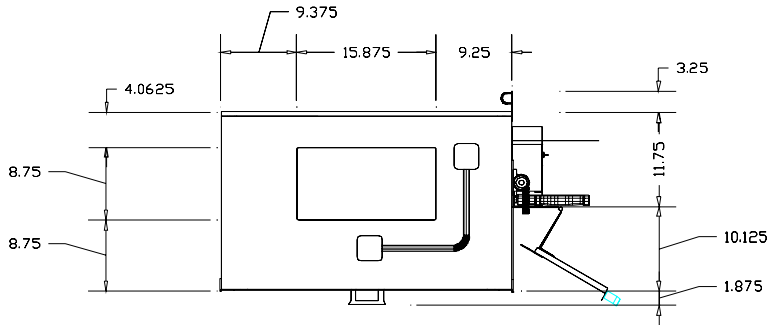

Top View

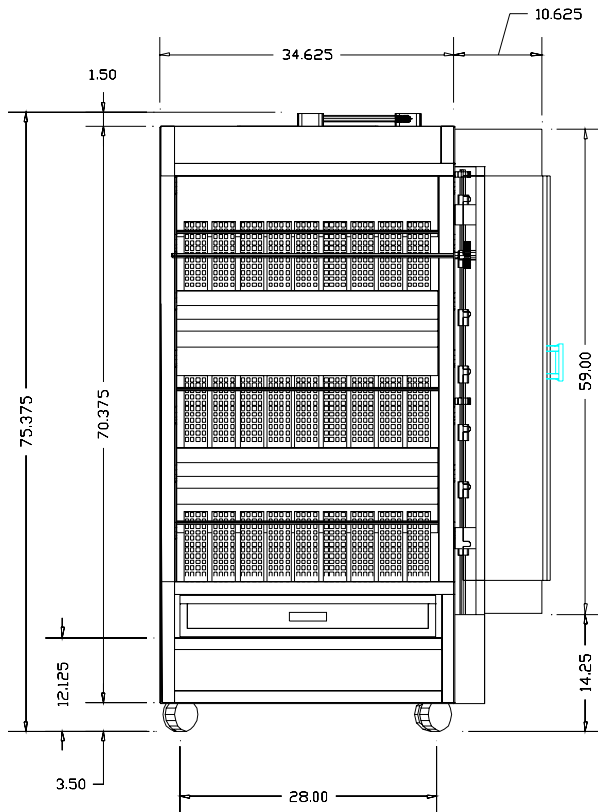

Front View

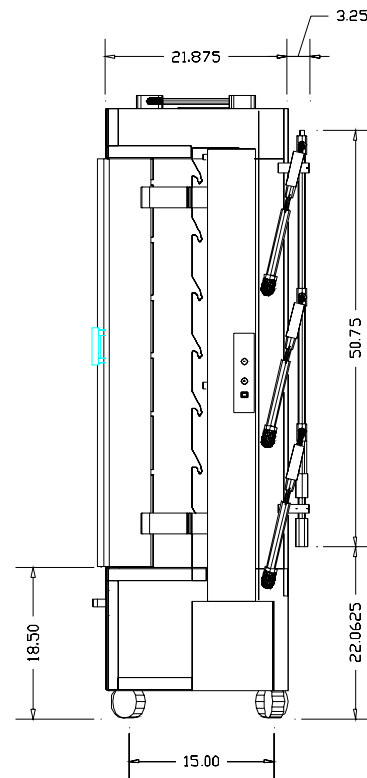

Right Side View

N / 9 G

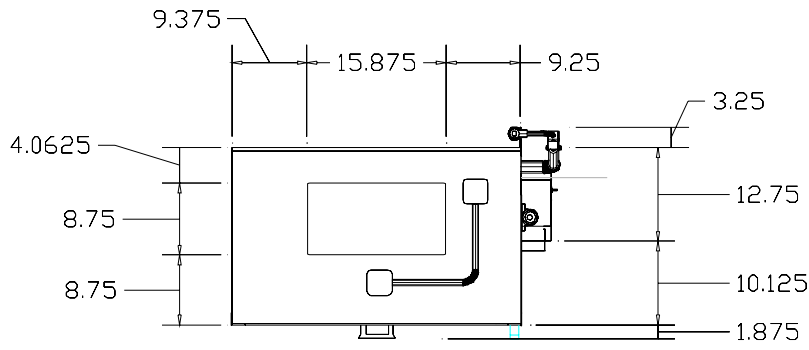

Top View

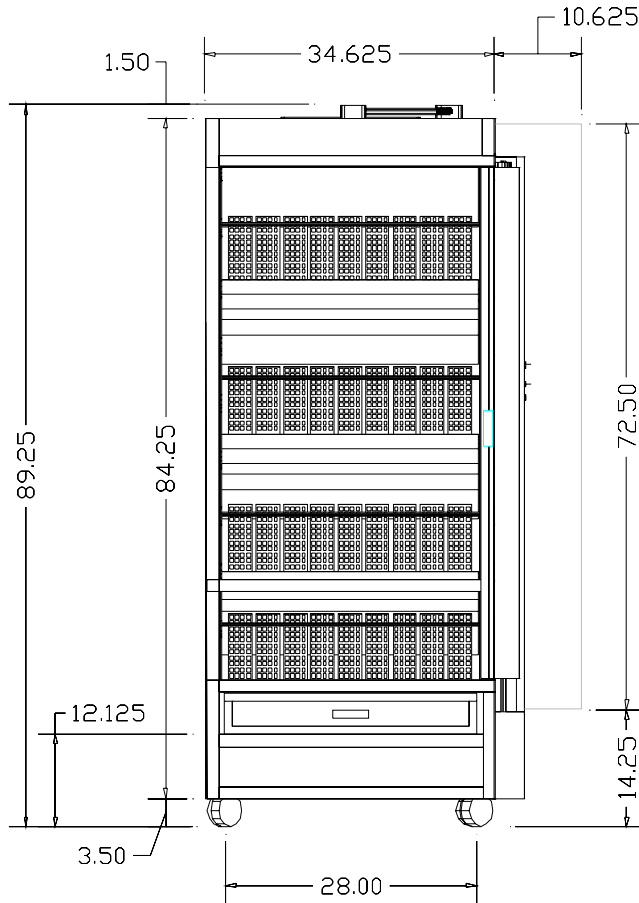

Front View

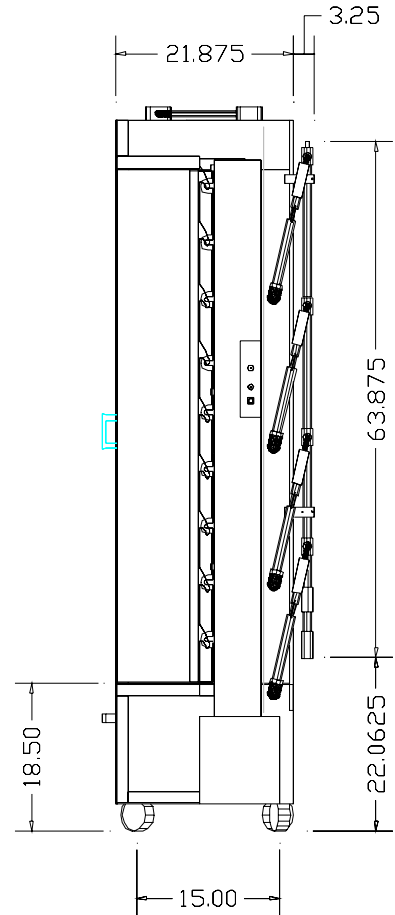

Right Side View

1.4 Main dimensions in inches

	N / 5-7 G	N / 9 G
Height	75.38"	89.25"
Width	45.25"*	45.25"*
Depth	27.00"	27.00"

* Dimension include hinged gas pipe cover.

1.5 Conversion and Adjustment Instructions

Before converting or adjusting the machine, it is imperative that the manual gas cock be turned to the "off" position. The electrical power to the machines should also be turned off. When converting from one type of gas to another, the main gas orifice (or injector), the pilot burner orifice (or injector), and the primary air adjustment must be changed according to the table on page 15. In addition, the spring in the pressure regulator must be changed so that it can operate at higher pressures.

1.6 Verification for use with Natural Gas

The highest flame setting ("on" position on the manifold gas valves) for each of the pipe burners can be confirmed by using the volumetric method in conjunction with the main gas meter. From the "pilot" position, turn the Gas Control Lever clock-wise, towards "on", until the lever goes no further.

To carry out this verification procedure, it is necessary to obtain the heating value (BTU/ft³) of the local gas from the local gas company.

If the measured gas volume does not correspond to the values in the following table, the first item which should be checked is the incoming (connected) gas pressure. If the pressure is correct, it must be verified that the proper size gas orifices are in place.

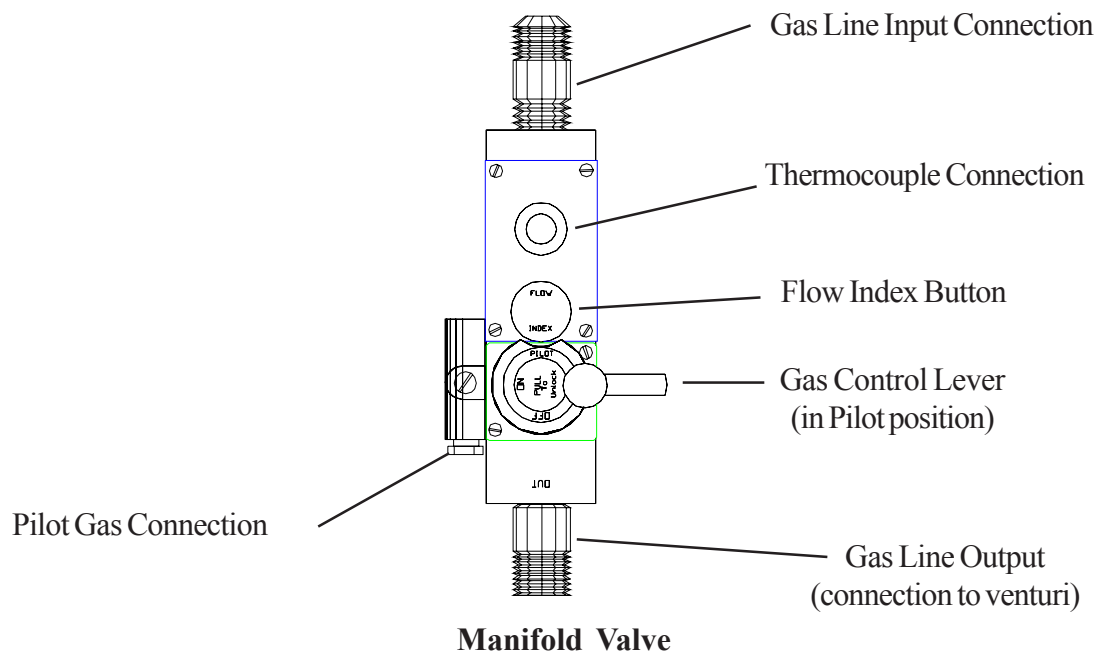

1.7 Natural Gas Flow Table

Gas	Heating Value in BTU/ft ³	Gas Flow per Burner (40,000 BTU) in ft ³ /hr High Flame Setting
Natural	1040	38.50
Propane	2500	16.00
Butane	2500	16.00

1.7.1 Volumetric Method to Verify the High Flame Setting, Mathematical

WARNING! No other gas equipment can be in operation during this procedure.

ATTENTION! Aucun autre équipement de gaz peut être en service au cours de cette procédure.

Calculation of flow rate E in ft³/hour

$$E = \frac{FP}{H_i}$$

E = Flow rate in ft³/minute

FP = High Flame Power setting in BTU/hr

H_i = Heating value in BTU/ft³

Thus, for natural gas:

$$E = \frac{40,000 \text{ BTU/hr}}{1040 \text{ BTU/ft}^3} = 38.50 \text{ ft}^3/\text{hr} = 0.64 \text{ ft}^3/\text{min.}$$

$$E = 0.64 \text{ ft}^3/\text{min.}$$

Calculation of the natural gas needed in 1 hour by a 9G (4 burners) at full power:

$$38.50 * 4 = 154 \text{ ft}^3/\text{hr} = 2.56 \text{ ft}^3/\text{min.}$$

The time and the flow measurements should be taken at the gas (flow) meter with a chronometer (stop watch).

To run the test, open the manual gas cock valve, start up the unit according to the start-up instructions on page 24 and set the manifold valves to the high flame setting ("on" position).

Allow the unit to pre-heat (burn) for 10 to 15 minutes. Verify that the flow rate is calibrated to the appropriate flow rate indicated in the table.

1.8 Orifice Diameters, Primary Air Intake Settings, and Pressure Regulators
Type N / 5 G - N / 7 G

Burner Position from Top to Bottom			
Gas / Pressure	Main Orifice	Pilot Orifice	Primary Air Intake
inches W.C.	Ø in drill size	Orifice Marking	in inches
Natural / 5.5"	#40	4211	3/16 " 1/8 " 1/8 "
Propane / 11"	#55	3221	3/16"
Butane / 11"	#55	3221	3/16"

Type N / 9 G

Burner Position from Top to Bottom			
Gas / Pressure	Main Orifice	Pilot Orifice	Primary Air Intake
inches W.C.	Ø in drill size	Orifice Marking	in inches
Natural / 5.5"	#40	4211	3/16 " 1/8 " 1/8 " 1/8 "
Propane / 11"	#55	3221	3/16"
Butane / 11"	#55	3221	3/16"

1.9 Changing Gas Orifices

1.9.1 Changing the Main Gas Orifice

1. The venturi tubes and manifold valves are on the same side as the spit handles.
2. On each venturi, loosen the lock nuts (7/8" wrench) and then move the nut and the air intake cap all the way to the top of the nipple.
3. With a 3/4" wrench, loosen the nipple so that it can be removed from the venturi.
4. With the nipple/orifice assembly off, separate the main orifice from the nipple with a pipe wrench or a pair of pliers.

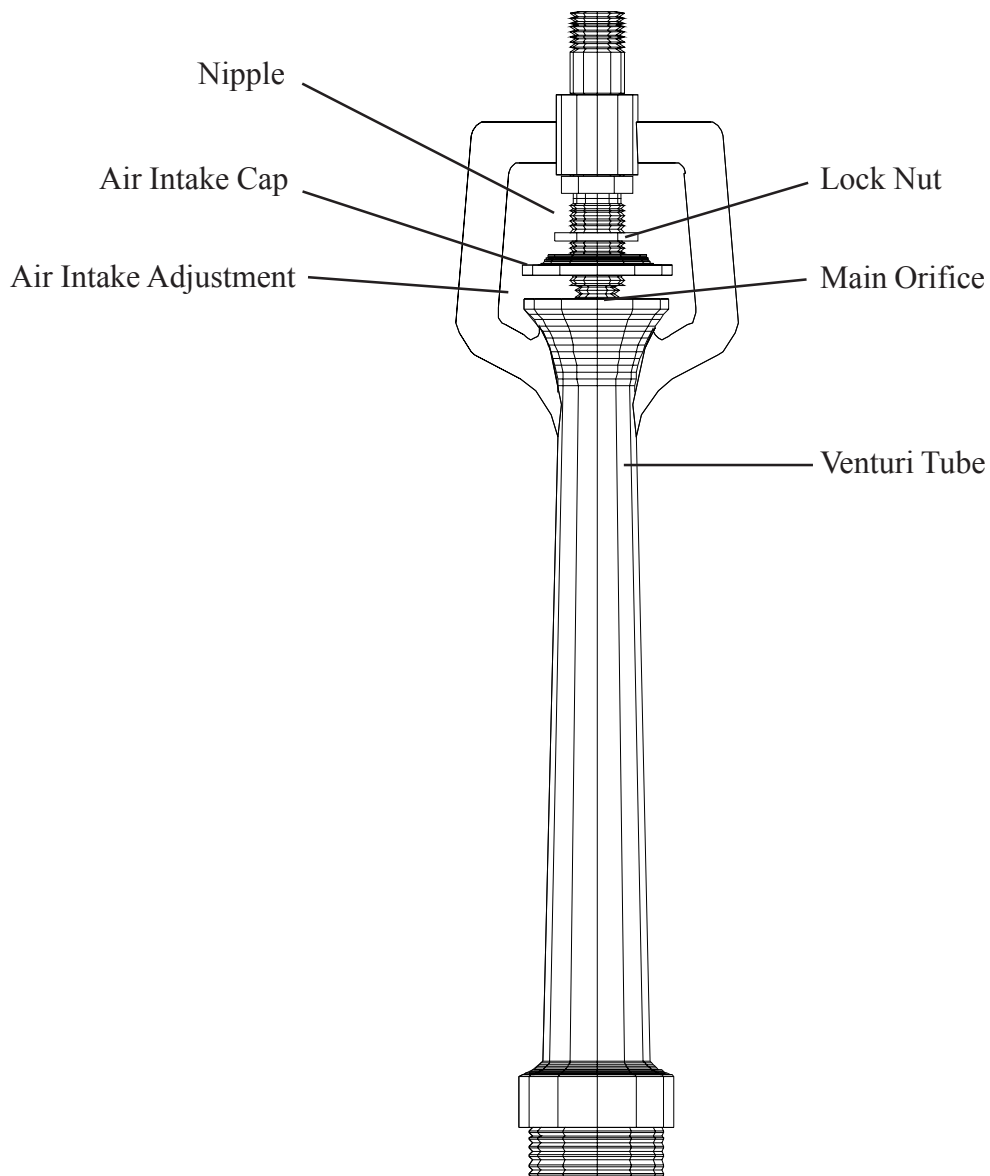

Venturi Assembly

Re-assemble all of the components with the new main orifice. Make sure that the proper air intake adjustment is made for the new type of gas (according to the tables on page 9). The flames should be blue in color, must be stable, and must not "lift off" the burner.

1.9.2 Changing the Pilot Orifice

1. To reach the pilot burner, open the sliding glass doors, the sliding or hinged metal door, remove all spits, as well as all ceramics.
2. Before removing, mark the position of the support bracket on the side wall.
3. Loosen the pilot burner assembly by removing the two screws which attach each pilot burner (support bracket) to the main body of the machine.
4. With the assembly loose, carefully pull the entire assembly forward about 6". Note that the pilot burner gas lines and the thermocouples are of flexible metals.

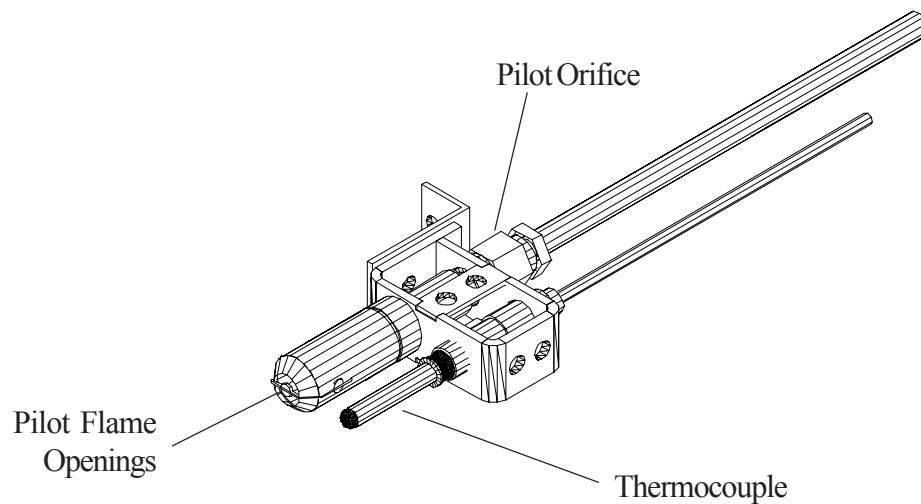

Pilot Burner Assembly

5. Loosen the gas line connection to the pilot orifice with a 7/16" wrench. Carefully separate the gas line from the pilot burner. From the pilot burner, carefully remove the pilot orifice using a 1/2" wrench.
6. Reassemble the pilot burner using the new pilot orifice and place the support bracket in its original position. The following pilot orifices are to be used with each type of gas.

Pilot Orifice	Marking
LPG	3221
Natural Gas	4211

1.10 Checking the Connected Gas Pressure (Nominal Pressure)

Close the gas cock where the gas line is connected to the machine and attach a manometer to the tap (allen screw) on the gas cock. With the manometer connected, open the gas cock, ignite all burners, and set the manifold valves to "on" or maximum setting. **Along with all other gas appliances at the location in operation, measure the gas pressure.**

This nominal pressure should be 5.5" W.C. for natural gas and 11" W.C. for LPG.

If the measured pressure falls below the range mentioned above, the installer should try to find the cause of the problem and resolve it. A typical source of this problem is that the gas line (pipe) diameter leading up to the unit is too small. If it is not possible to resolve the problem, the local gas company or gas supplier should be contacted so that they can resolve the problem.

If the nominal pressure is below 5.5 " W.C. for natural gas or below 11 " W.C. for LPG, the unit should not be operated. These should be adjusted to the ideal settings using the pressure regulating screw on the pressure regulator.

If the pressure is too high and can not be adjusted downward, check to see if the proper adjusting spring is in place. If this is correct, the regulator membrane may have been ruptured by excessive gas pressure and may have to be replaced. Do not operate the rotisserie if the gas

If the pressure is too low and can not be adjusted upward, also check the regulator. If this is correct, verify the pressure coming out of the main gas meter or the diameter of the gas pipe feeding gas to the unit. If the gas line is under-sized, the appropriate pressure may not be reached. Do not operate the unit if the pressure falls below 5.5" W.C.

After the pressure has been set, close the gas cock once again, remove the manometer, seal the pressure regulator, and then re-open the gas cock.

WARNING: After an installation, repairs, or maintenance, make sure that there are no gas leaks anywhere in the gas lines or system.

AVERTISSEMENT: Après une installation , la réparation ou l'entretien , assurez-vous qu'il ya aucune fuite de gaz partout dans les conduites de gaz ou de système.

1.11 Maintenance, response to technical problems, reasons for problems and solutions

Should a technical problem arise for any reason, shut off the machine and call for technical service.

A routine maintenance should be carried out at least once a year. Contact your local, certified service company for maintenance.

Problem	Cause	Solution
Burners do not ignite.	a. No gas flow. b. Gas container too cold especially with butane. Water in gas freezes in gas regulator.	a. Make sure that all gas valves are open and that gas is reaching unit. b. Remove and control the gas valve at the connection (manual) or the LPG pressure regulator. Contact gas company or distributor.
Pilot burner ignites. Main burner initially ignites, but then goes out.	a. Thermocouple tip is not enveloped by pilot flame. b. Thermocouple is not heated enough by flame or it is being heated along the entire length too much. c. Primary air intake blocked or must be adjusted. d. Thermocouple is loose at one of the connections. e. Defective thermocouple.	a. Adjust thermocouple position. b. Only the themocouple tip should be enveloped by the pilot flame and heated. The pilot flame must be strong and blue in color. c. Clean or adjust opening according to table in page 9. d. Tighten all thermocouple connections. e. Replace thermocouple (service co.).
Burners too weak.	a. Gas pressure too low. b. Wrong orifice size.	a. Contact service or gas company. b. Install correct orifices.
Burner back-fires.	Too much primary air.	Adjust the primary air intake. (contact service company)
Pilot flame does not stay on.	a. Flames on pipe burners disrupting pilot flame. b. Defective thermocouple.	a. Block off holes on the main burner pipe directly below the pilot burner. b. Replace thermocouple (service co.).

1.12 Testing or checking for safety

After a conversion, a new installation, or after a repair, it is important that the unit be tested to insure that it operates properly. This should include the following:

Test for gas leaks.

Check that the unit has enough clearance behind and to the sides.

Check that enough primary and secondary air is available (strong blue flames).

Check for potentially flammable objects or potential flammability problems.

Check the gas distribution systems.

Check for proper ventilation and exhaust.

Check for proper room ventilation.

1.13 For Proper Operation

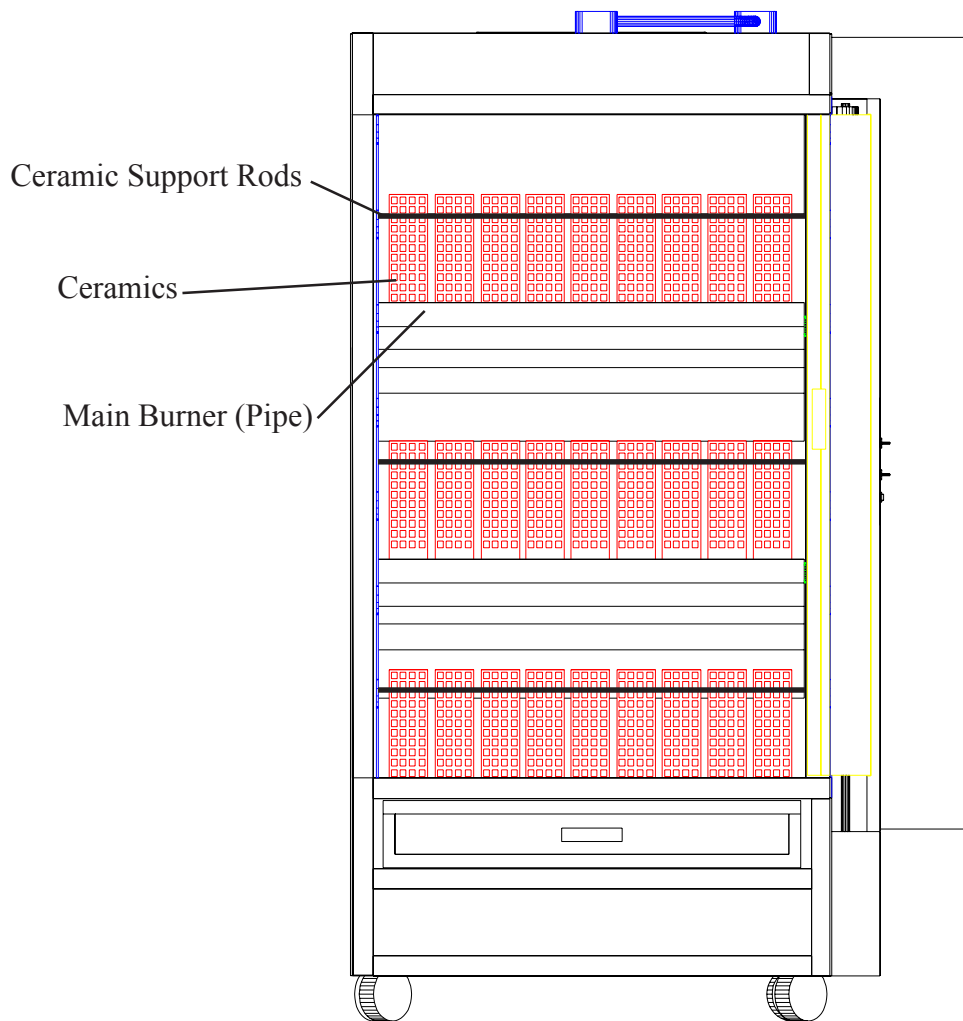

When first installing, after repairing, or after cleaning the units, it is important to make sure that all components are properly in place.

- a. There should be a total of 9, evenly spaced ceramic bricks sitting above each main pipe burner.
- b. The ceramics **must** be sitting directly on the burners. These ceramic bricks should also be placed so that they fit between the ceramic support rods.
- c. The burner pipes should not have any holes (flames) directly below the pilot burner assembly. If holes (flames) are present, they will overheat the thermocouple or blow out the pilot flame, preventing the main burner from staying lit.

1.14 Description of the Electrical Connection

The electrical connections are to be made in accordance to local and national codes.

All gas machines operate with 120 Volt, single phase, 60 Hz. A NEMA 5-15P plug is supplied with the units.

All pertinent electrical information can be taken from the electrical diagram.

1.15 Electrical Diagram - All Models

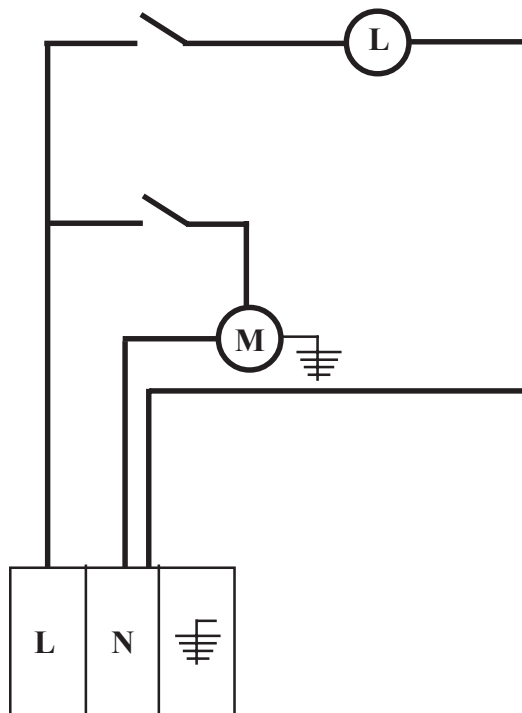

1.16 Parts List for N / 5G and N / 7G with Diagrams

Item	Qty.	Description	Material	Length	Size	Manufacturer
113	27	Ceramic Radiants (Single Face)	Ceramic			Hickory
116	1	Sliding Door	SS			Hickory
118T	1	Door Slide Assembly Long, Top	SS			Hickory
118B	1	Door Slide Assembly Long, Bottom	SS			Hickory
120	1	Drip Pan	SS			Hickory
121	1	Drip Pan Plug	Brass			Hickory
122	1	Drip Pan Receptacle	Brass			Hickory
131	1	Fiber Motor Worm Gear	Fiber			Hickory
144T	1	Glass Track, Top	SS			Hickory
144B	1	Glass Track, Bottom	SS			Hickory
145	2	Glass Trolley, Regular	Alum.			Hickory
147	2	Handle	Plastic			Hickory
150	1	Lamp Par, 240 V				Hickory
155	1	Motor, 1/3 HP - 240V				Hickory
157	1	Motor Worm Steel	SS			Hickory
158	5 or 7	Oil Lite Bushing	Brass			Hickory
159	3	Pillow Block Bearing 5/8"	SS			Hickory
173	2	Reflector Panel Gas Curved	SS			Hickory
174	3	Reflector Panel Gas Flat	SS			Hickory
182	1	Shaft 5/8"	SS			Hickory
184	9	Shaft Worm	Nylon			Hickory
201	1	Spit Lock, N / 5	SS			Hickory
202	1	Spit Lock, N / 7	SS			Hickory
210I	1	Spit Plate, N / 5 Interior	SS			Hickory
210E	1	Spit Plate, N / 5 Exterior	SS			Hickory
211I	1	Spit Plate, N / 7 Interior	SS			Hickory
211E	1	Spit Plate, N / 7 Exterior	SS			Hickory
223	1	Top Reflector Single	SS			Hickory
227	3	Venturi Cap	Iron			Hickory
229	3	Venturi Lock Nut 3/8" ID, 3/4" OD	Iron			Hickory
231	3	Venturi Nipple	Steel			Hickory
233	3	Venturi Threading Tube, Brass	Steel			Hickory
234	3	Venturi Tube	Iron			Hickory
232	3	Main Orifice, Nat. Gas	Brass			Hickory
162	3	Pilot Burner (includes pilot orifice)	Steel			Hickory
163	3	Pilot Gas Line	Alum.			Hickory
164	3	Pilot Thermocouple	Copper			Hickory
138	3	Gas Pipe Burner	Steel		1 - 1/2"	Hickory
175	6	Retainer Rod for Ceramics	SS			Hickory
152	1	Lamp Socket	Ceramic			Hickory
214	2	Switch, 1-Pole				Hickory
110	2	Caster w/ brake	Nylon			Hickory
111	2	Caster w/o brake	Nylon			Hickory

1.16 Parts List for N / 5-7 G with Diagrams (Contd.)

Item	Qty.	Description	Material	Length	Size	Manufacturer
189		5 or 7 Spit Regular Complete (with screws)	SS			Hickory
179		2/spit Roll Pin 1/8" Stainless	SS			Hickory
190		5 or 7 Spit Regular, without collar	SS			Hickory
191		5 or 7 Spit Collar	SS			Hickory
192		5 or 7 Spit Gear	Nylon			Hickory
193		5 or 7 Spit Handle, 8" Regular	Nylon			Hickory
185		5/Spit Skewer Double	SS			Hickory
186		5/Spit Skewer Single	SS			Hickory
219		1/Acc.Thumb Screw	Steel			Hickory
165	1	Pressure Regulator (Connection)	Alum.		3/4"	Maxitrol
7A	1	Pipe	Steel	3.5"	3/4"	Hickory
135	1	Gas Cock Valve	Steel		3/4"	
7B	1	Pipe	Steel	6"	3/4"	Hickory
7C	3	T-Connector	Steel		3/4"	Hickory
7D	6	Nipple (Adapter 3/4" to 3/8")	Steel	1.7"		Hickory
132	3	Flexible Pipe	SS	4.25"	3/8"	Dormont
180	3	Manifold Gas Valve	SS		3/8"	Baso
7E	3	Nipple	Steel	1.5"	3/8"	Hickory
226	3	Venturi Assembly	Iron		3/8" - 1-1/2"	Hickory
228	3	Venturi Elbow, 90°	Iron		1-1/2"	Hickory
7F	1	Pipe	Steel	14.5"	3/4"	Hickory
7G	1	Pipe	Steel	16"	3/4"	Hickory
7H	1	Pipe Cap (threaded)	Steel		3/4"	Hickory

The following parts are not shown in the diagrams:

123	1	Electrical Grounding Cap			Hickory
		Electrical Wire			Janor Wire
	1	Connection Cable			TIP Products
104	1	Contact Section 242 (terminal)			Buchanan
105	1	Contact Section 250 (end-piece)			Buchanan
143	2	Glass Tempered, 381 x 559 mm			Hickory
148	1	Lamp Cover, Regular			Hickory

*All components are inventories and sold through Hickory Industries and their distributors and dealers.

N/7GP Breakdown

(2/14/2017)

7gpexp lod. dwg

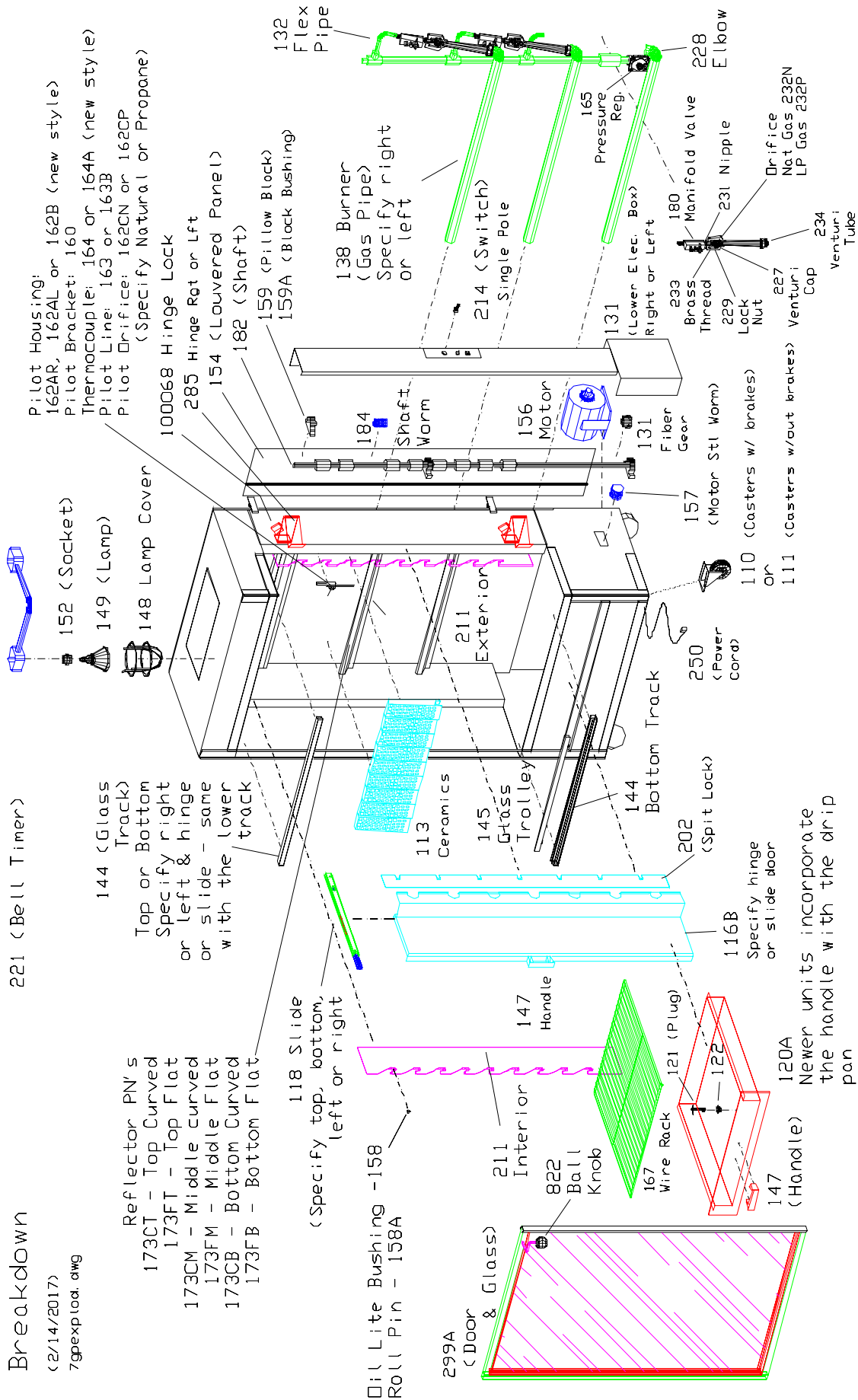

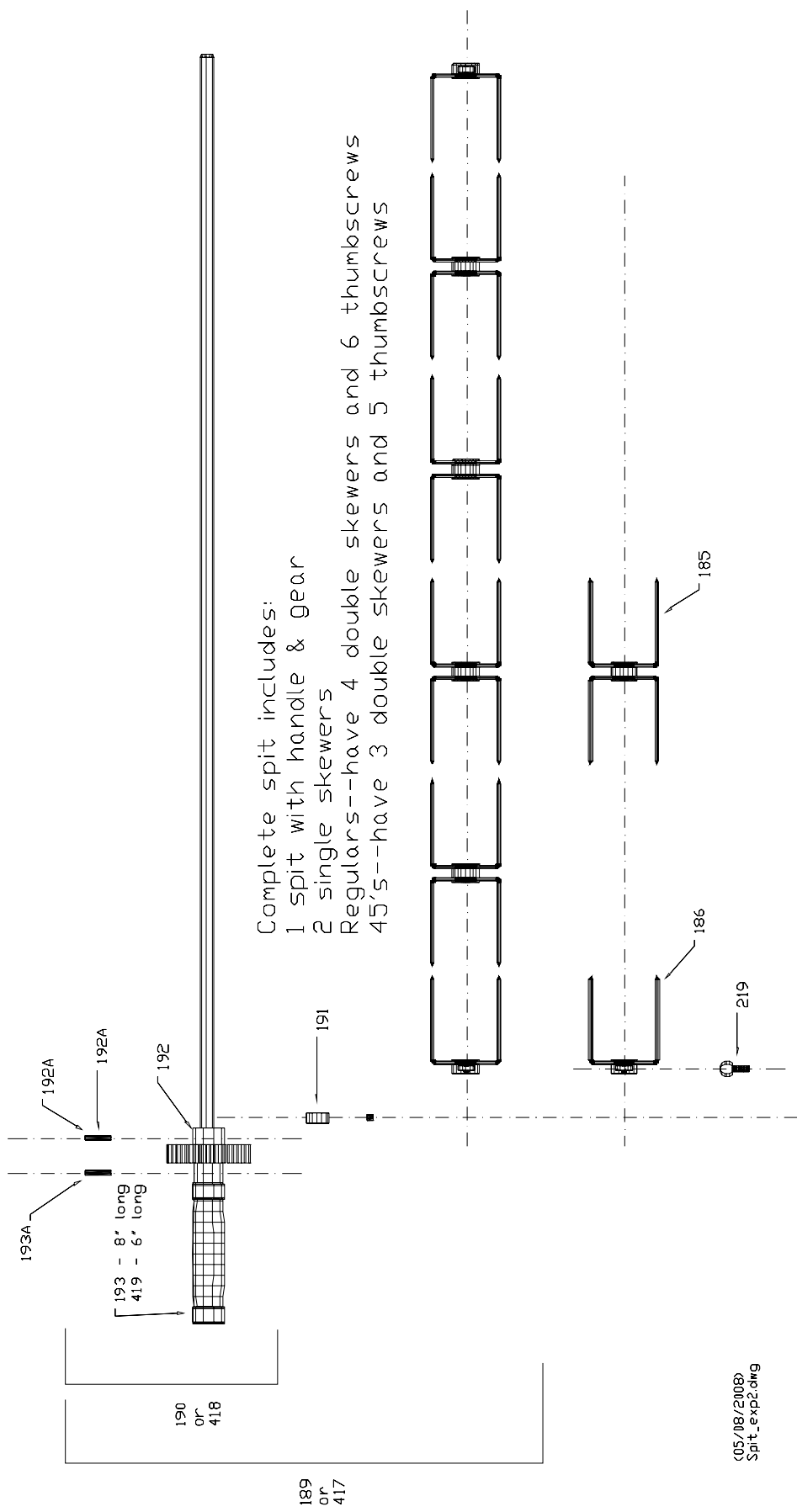

Complete spit includes:
 1 spit with handle & gear
 2 single skewers
 Regulars--have 4 double skewers and 6 thumbscrews
 45's--have 3 double skewers and 5 thumbscrews

(05/08/2008)
 Spit_exp2.dwg

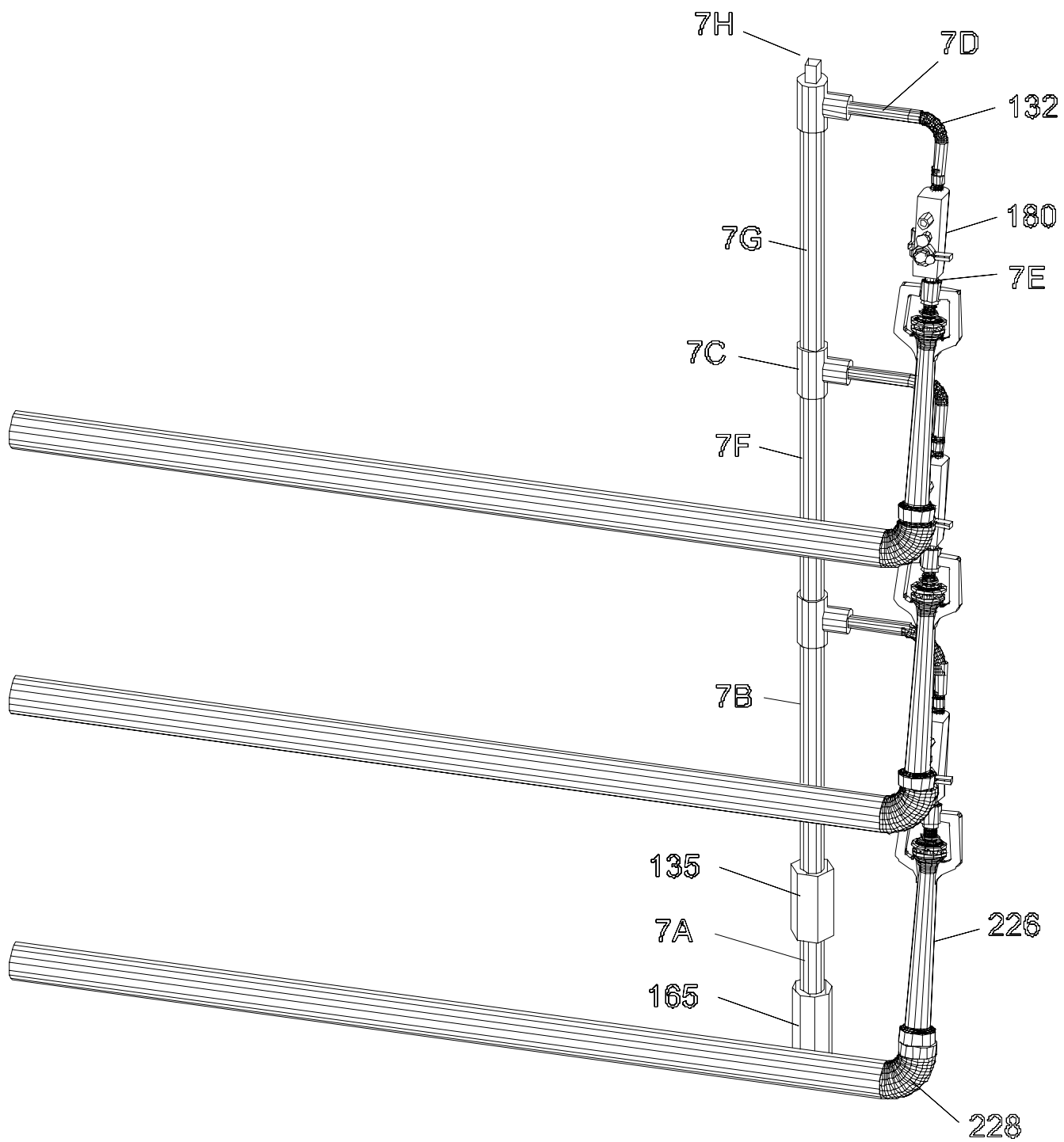

1.17 Parts List for N / 9 G

Item	Qty.	Description	Material	Length	Size	Manufacturer
113	36	Ceramic Radiants (Single Face)	Ceramic			Hickory
117	1	Sliding Door	SS			Hickory
118T	1	Door Slide Assembly Long, Top	SS			Hickory
118B	1	Door Slide Assembly Long, Bottom	SS			Hickory
120	1	Drip Pan	SS			Hickory
121	1	Drip Pan Plug	Brass			Hickory
122	1	Drip Pan Receptacle	Brass			Hickory
131	1	Fiber Motor Worm Gear	Fiber			Hickory
144T	2	Glass Track, Top	SS			Hickory
144B	2	Glass Track, Bottom	SS			Hickory
145	4	Glass Trolley, Regular	Alum.			Hickory
147	2	Handle	Plastic			Hickory
150	1	Lamp Par, 240 V				Hickory
155	1	Motor, 1/3 HP - 240V				Hickory
157	1	Motor Worm Steel	SS			Hickory
158	9	Oil Lite Bushing	Brass			Hickory
159	3	Pillow Block Bearing 5/8"	SS			Hickory
173	3	Reflector Panel Gas Curved	SS			Hickory
174	4	Reflector Panel Gas Flat	SS			Hickory
183	1	Shaft 5/8"	SS			Hickory
184	9	Shaft Worm	Nylon			Hickory
203	1	Spit Lock, N / 9	SS			Hickory
212I	1	Spit Plate, N / 9 Interior	SS			Hickory
212E	1	Spit Plate, N / 9 Exterior	SS			Hickory
223	1	Top Reflector Single	SS			Hickory
227	4	Venturi Cap	Iron			Hickory
229	4	Venturi Lock Nut 3/8" ID, 3/4" OD	Iron			Hickory
231	4	Venturi Nipple	Steel			Hickory
233	4	Venturi Threading Tube, Brass	Steel			Hickory
234	4	Venturi Tube	Iron			Hickory
232	4	Main Orifice, Nat. Gas	Brass			Hickory
162	4	Pilot Burner (includes pilot orifice)	Steel			Hickory
163	4	Pilot Gas Line	Alum.			Hickory
164	4	Pilot Thermocouple	Copper			Hickory
138	4	Gas Pipe Burner	Steel		1 - 1/2"	Hickory
175	6	Retainer Rod for Ceramics	SS			Hickory
152	1	Lamp Socket	Ceramic			Hickory
214	2	Switch, 1-Pole				Hickory
110	2	Caster w/ brake	Nylon			Hickory
111	2	Caster w/o brake	Nylon			Hickory

1.17 Parts List for N / 9 G (Contd.)

Item	Qty.	Description	Material	Length	Size	Manufacturer
189	9	Spit Regular Complete (with screws)	SS			Hickory
179	18	Roll Pin 1/8" Stainless	SS			Hickory
190	9	Spit Regular, without collar	SS			Hickory
191	9	Spit Collar	SS			Hickory
192	9	Spit Gear	Nylon			Hickory
193	9	Spit Handle, 8" Regular	Nylon			Hickory
185	5/Spit	Skewer Double	SS			Hickory
186	5/Spit	Skewer Single	SS			Hickory
219	1/Acc.	Thumb Screw	Steel			Hickory
165	1	Pressure Regulator (Connection)	Alum.		3/4"	Maxitrol
9A	1	Pipe	Steel	3.5"	3/4"	Hickory
135	1	Gas Cock Valve	Steel		3/4"	
9B	1	Pipe	Steel	5.5"	3/4"	Hickory
9C	4	T-Connector	Steel		3/4"	Hickory
9D	8	Nipple (Adapter 3/4" to 3/8")	Steel	1.7"		Hickory
132	1	Flexible Pipe	SS	4.25"	3/8"	Dormont
180	4	Manifold Gas Valve	SS		3/8"	Baso
9E	4	Nipple	Steel	1.5"	3/8"	Hickory
226	3	Venturi Assembly	Iron		3/8" - 1-1/2"	Hickory
228	3	Venturi Elbow, 90°	Iron		1-1/2"	Hickory
9F	1	Pipe	Steel	13.5"	3/4"	Hickory
9G	2	Pipe	Steel	14.5"	3/4"	Hickory
9H	1	Pipe Cap (threaded)	Steel		3/4"	Hickory

The following parts are not shown in the diagrams:

123	1	Electrical Grounding Cap			Hickory
		Electrical Wire			Janor Wire
	1	Connection Cable			TIP Products
104	1	Contact Section 242 (terminal)			Buchanan
105	1	Contact Section 250 (end-piece)			Buchanan
143	2	Glass Tempered, 381 x 559 mm			Hickory
148	1	Lamp Cover, Regular			Hickory

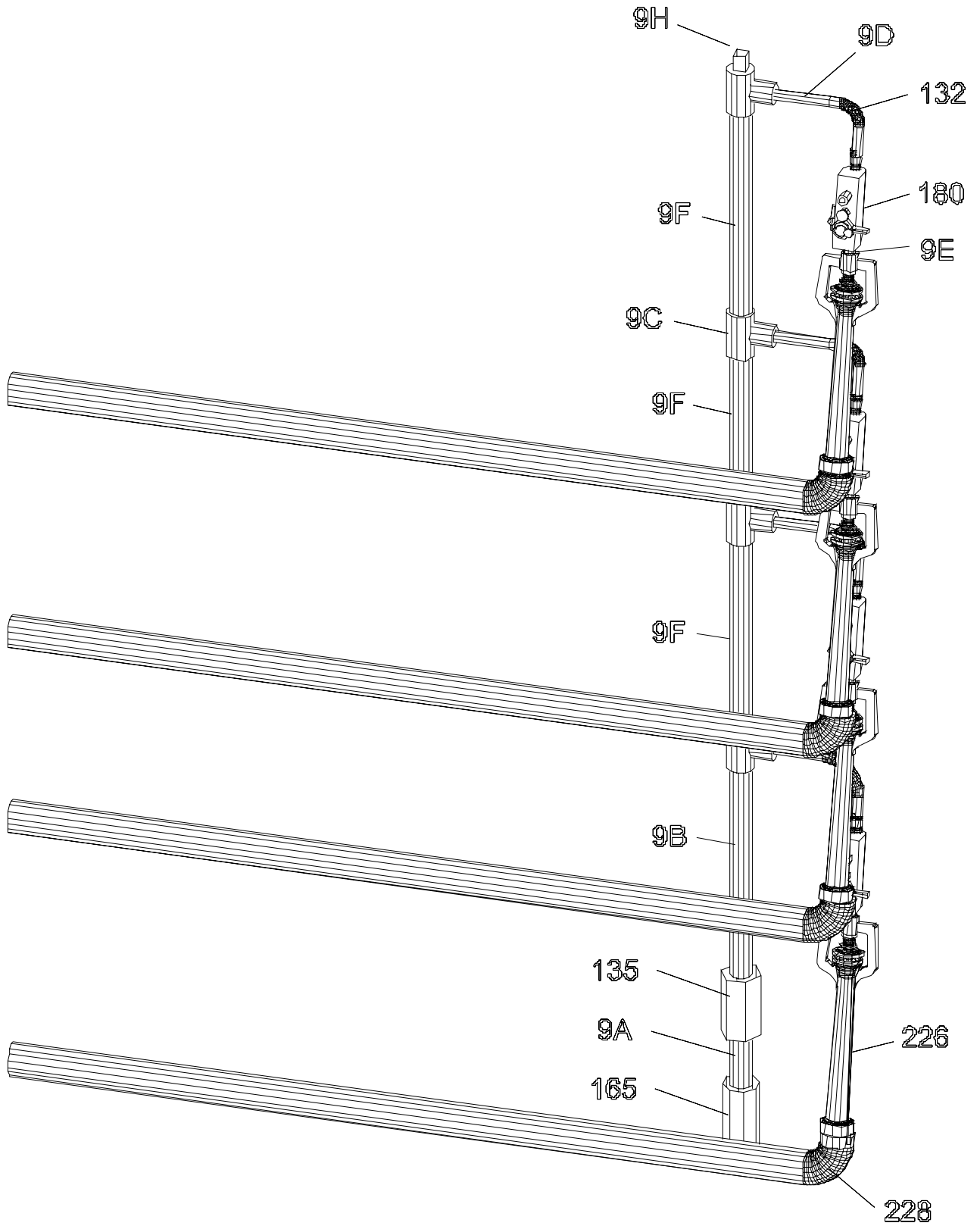

2 Operating Instructions

2.1 Start Up

1. Switch the exhaust hood to on.
2. Open the gas cock at the rear of the machine.
3. Turn the knob on the manifold valve to the "pilot" position.
4. While pressing the "flow index" button down, place a match, or other type of ignition method, to the pilot burner until it is lit. Keep the knob pressed down for at least 40- 60 seconds so that the thermocouple tip warms up and the pilot flame remains lit.
5. Release the knob. The pilot flame should stay on.
6. Repeat the procedure for the other burners.
7. Turn the manifold valve knob to the desired setting ("on" must be lined up with the "flow index" button for high flame or maximum heat). The pipe burner should now light up.
8. Allow the unit to pre-heat for about 15 minutes.
9. When ready to load the spits with product, turn the light and the motor switches to the on position.

2.2 Shut Down

1. Turn the manifold valve knobs to the "off" position if all flames are to be shut off. If the pilot light is to remain lit and only the pipe burners are to be shut off, turn the manifold valve knobs to the "pilot" position. Note that to turn the knobs to the "off" position, one must pull out on the locking mechanism on the knobs and then turn the valve to the off position.
2. After all of the loaded spits have been removed, turn the motor and lights off.
3. Close the gas cock at the rear of the machine if the pilot flames are also shut off.
4. Turn off the exhaust hood.

WARNING! Do not clean the machine or glass while these are hot! Everything should be cooled down before cleaning.

**ATTENTION! Ne pas nettoyer la machine ou de verre tandis que ceux-ci sont chauds!
Tout doit être refroidi avant de le nettoyer .**

2.3 Working with the Rotisserie

Grilling Temperature

The desired temperature in the rotisserie can only be set with the manifold valve knob. Setting "on" is for the high flame setting and represents about 540°F. The grilling temperature can be reduced by turning the knob counter clock-wise (CCW), towards the "pilot" position.

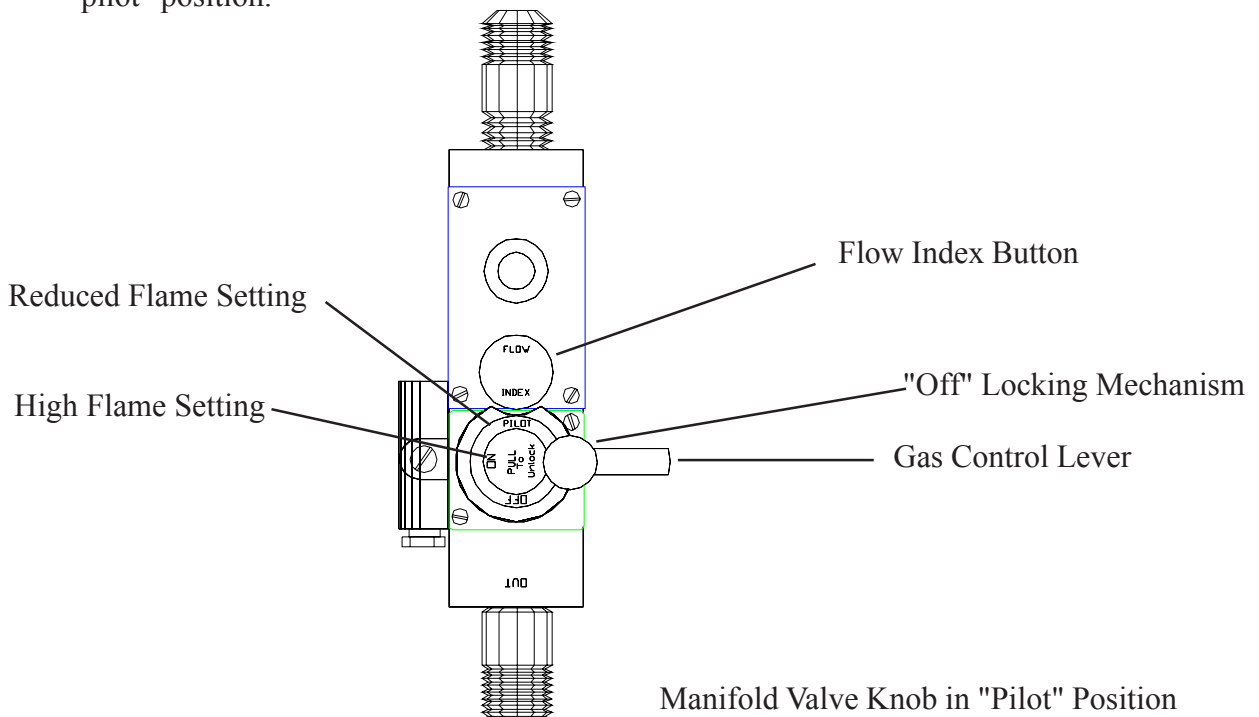

As a general rule, the higher the grilling temperature, the shorter the cooking time. However, when working with the Old Hickory rotisserie, one must consider that the temperatures will vary from top to bottom. The top of the unit will have higher temperatures due to the natural convection. The cooking temperatures indicated above refer to the top section of the machine. For this reason, the product on the top spits will be cooked faster than the product on the lower spits.

This factor allows for continuous cooking. As the top spits are ready, they should be removed. The spits directly below should then be moved up one spit position, thus freeing a spit position at the bottom of the unit. This bottom position can then be loaded with fresh, raw product. By loading raw product to the bottom, there is no danger of cross contamination.

WARNING: The only way to be sure that the product is completely cooked is by taking the internal temperatures. For example, with poultry, the internal temperature must be at least 185°F at the inner side of the thigh.

AVERTISSEMENT : La seule façon d'être sûr que le produit est complètement cuit est par en prenant les températures internes . Par exemple, avec les volailles la température interne doit être d'au moins 185 °F au niveau du côté interne de la cuisse .

For example, when preparing chicken.

- a. After the unit has been ignited and it has warmed up for at least 15 minutes, load all spits with chicken.
- b. Depending on the size and weight of the chickens, check the internal temperature of a chicken (on the inner thigh) on the top spit after approximately 55 minutes. If the internal temperature exceeds 185°F, remove the top spit.
- c. Move the remaining spits up one spit position. The bottom spit position should now be free.
- d. Add a new spit, loaded with raw chickens, to the bottom spit position.
- e. Repeat this procedure as needed during the day.
- f. After the "rush" has ended and demand has decreased, turn the manifold valve knobs to the low temperature settings. This will keep the product in the rotisserie hot over a long period of time, without burning the product.

2.4 Cooking Times

Product	Cooking Time	Temperature
Chicken	45 - 60 minutes	"ON"
Turkey	120 - 170 minutes	1/2 power increase to "ON" for last 20 min.
Ribs	20 - 45 minutes	"ON"
Beef Roast	45 minutes (to 104°F)	"ON"
Pork Loin	45 minutes (to 135 °F)	"ON"
Salmon	20 - 30 minutes	"ON"
Duck	120 minutes	1/2 power - 105 minutes "ON" - 15 minutes
Vegetables (Zucchini)	20 minutes	"ON"
Potatoes	40 minutes	"ON"

2.5 Daily Cleaning

The rotisserie should be cleaned on a daily basis.

1. The exterior should be cleaned with a stainless steel cleaner.
2. The glass should be cleaned with a soft cloth and degreaser. If necessary, a plastic scraper can also be used to remove carbon when using a degreaser.

WARNING! The glass must be cool. Do not use steel wool or abrasives to clean the glass! This will weaken the tempered glass and could cause it to shatter.

ATTENTION! Le verre doit être cool . Ne pas utiliser de laine d' acier ou d'abrasifs pour nettoyer le verre! Cela va affaiblir le verre trempé et pourrait causer à briser .

3. The spits and drip pans should be removed from the machine and cleaned thoroughly with a degreaser.
4. Before cleaning the interior surfaces carefully cover, protect, or remove all ceramics.
5. The interior stainless steel surfaces can be sprayed with a degreaser for best results.
6. For best results on the interior metal, use a steam cleaner or a scrubbing sponge. Be careful not to use excessive water since this could damage the insulation on the rear, side, and front panels.
7. The filters in the exhaust hood must be cleaned as required by the manufacturer.

2.6 Important Information

In case of repairs, only an approved and certified service technician should be called in.

The installation can only be carried out by a certified installer. Otherwise, the warranty will be null and void.

Hickory

Cleaning Instructions for Continuous Cook Rotisseries

The most effective maintenance procedure that you can perform will be the daily cleaning procedure

Prior to First Cook:

While the oven is still cold – spray all interior panels with KOTE.

FOR GAS MODELS

Using the shield provided, cover the top row of ceramics and spray the interior of that area with KOTE. Repeat the process covering the remaining rows of ceramics.

DO NOT SPRAY KOTE DIRECTLY ON THE CERAMICS OR THE PILOT LIGHTS.

FOR ELECTRIC MODELS

When spraying KOTE near the elements, adjust the spray nozzle pattern and try not to spray directly on the elements.

Remove the wire rack located above the drip pan and spray the sides of the drip pan with KOTE. Replace the wire rack and spray it with KOTE.

After Each Cooking Cycle

Spray the inside of the glass doors with an approved glass cleaner and wipe with a soft cloth.

Drain the greasy water from the drip pan and replenish with fresh water.

At The End of Each Day

Turn burners valves or element switches to the “OFF” position and allow the oven to cool down.

Remove any spits or baskets – allow them to soak for 15 – 20 minutes, using a solution of warm water and detergent. Rinse clean, following guidelines for rinsing & sanitizing.

Remove the wire rack – and clean it in the sink using a solution of warm water and detergent.

Drain the greasy water from the drip pan and replenish with a solution of warm water and detergent.

Using either a sponge or a cloth - wipe down the interior of the oven with the solution removing any grease/fat. Wipe dry the interior of the oven with a soft cloth.

USE CARE WHEN CLEANING NEAR THE PILOT ASSEMBLY. IF YOU ACCIDENTALLY MOVE THE THERMOCOUPLE, BE SURE THAT YOU SNAP IT BACK INTO POSITION.

Drain the solution from the drip pan, wipe clean and return to the oven along with the wire rack.

Clean the glass with an approved glass cleaner. Do not use abrasives or razor blades as they will mar and/or scratch the surface causing it to break without notice.

Wipe clean the area around the controls with a sponge or soft cloth.

GAS MODELS

RE-LIGHT THE PILOTS AND TURN ON ALL BURNERS (SET TO HIGH).

ELECTRIC MODELS

TURN ON ALL OF THE ELEMENTS.

RUN THE UNIT FOR APPROXIMATELY 5 MINUTES TO BURN OFF ANY CHEMICAL RESIDUE THAT MAY BE REMAINING FROM THE CLEANING PROCEDURE.

Recommendation – now would be a good time to spray the interior of the oven with KOTE. You will be prepared for tomorrow’s cooking cycle.

NOTE: *On a monthly basis, to ensure that the burner is operating efficiently, remove the ceramics and use a paper clip to clean any debris from the burner openings. Additionally the venturi air inlet gap needs to be cleaned. This can be done using a paring knife or business card. Refer to the operating manual.*

Hickory

Maintenance Procedures for Continuous Cook Rotisseries

The most effective maintenance procedure that you can perform will be the daily cleaning procedure.

Monthly:

To ensure that the burner is operating efficiently, remove the ceramics and use a paper clip to clean any debris from the burner openings.

To ensure proper air/gas mixture, the venturi air inlet gap needs to be cleaned. This can be done using a paring knife or business card. Refer to the operating manual.

Every 6 Months:

To ensure that the shaft worm nylon gears properly mesh with the spit gears, place a spit into each spit position with the motor running. If the gears jump or do not align properly, adjust them using the allen wrench provided – ***DO NOT OVER TIGHTEN THE SCREWS.***

Every 12 Months:

Inspect the spit plates and verify that the brass oil lite bushings are in place for each spit position. Replace any worn or missing bushings.

Remove the glass and inspect for scratches and or chips. If any are found replace the glass as soon as possible. Also, inspect the glass trolleys. If they are worn, replace them.

Units with sliding side doors – the upper and lower slides needed to be greased.