



Read all instructions before assembly and use.  
**KEEP INSTRUCTIONS FOR FUTURE USE.**

Lisez toutes les instructions avant l'assemblage et l'utilisation.  
**CONSERVEZ LES INSTRUCTIONS POUR UN USAGE ULTERIEUR.**

Lea todas las instrucciones antes de ensamblar y usar.  
**MANTENGA LAS INSTRUCCIONES PARA SU USO FUTURO.**



**Dresser With Changing Top**  
**Commode avec plan à langer**  
**cómoda con el cambiador**

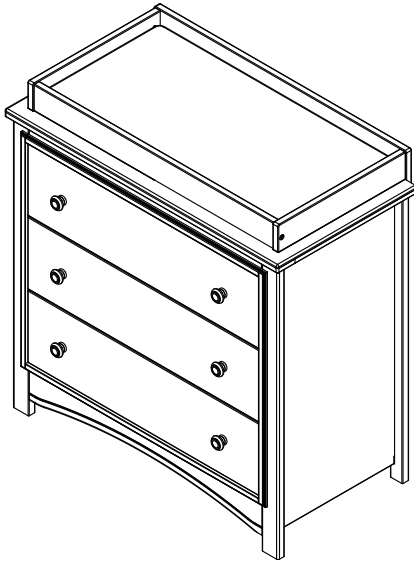

Style #: \_\_\_\_\_  
 A Lot: \_\_\_\_\_  
REV  
 Date: \_\_\_\_\_

**⚠ ADULT ASSEMBLY REQUIRED**  
Due to the presence of small parts during assembly, keep out of reach of children until assembly is complete.

**⚠ L'ASSEMBLAGE DOIT ETRE FAIT PAR UN ADULTE**  
A cause de la presence de petites pieces, pendant l'assemblage gardez hors de portee des enfants jusqu'a ce que celui-ci soit termine.

**⚠ DEBE SER ENSAMBLADO POR UN ADULTO**  
Debido a la presencia de piezas pequeñas durante el ensamblaje, mantenga fuera del alcance de los niños hasta que complete el ensamblaje.

**This product is not intended for institutional or commercial use.**  
**Ce produit ne pas destine a un usage institutionnel ou commercial.**  
**Este producto no esta hecho para uso institucional o comercial.**

**NEED EXTRA HELP?**

We make assembly easy with our tips & tricks video  
<https://www.deltachildren.com/pages/instructions>

**BESOIN D'AIDE SUPPLÉMENTAIRE?**

Nous facilitons l'assemblage avec nos trucs et astuces vidéo  
<https://www.deltachildren.com/pages/instructions>

**¿NECESITA AYUDA EXTRA?**

Hacemos el montaje fácil con nuestros consejos y trucos video  
<https://www.deltachildren.com/pages/instructions>

When contacting Delta Consumer Experience Center please reference the above information. Before contacting Delta Consumer Experience Center please ensure that the information above matches the information found on the label on the *Back Panel*, please reference the information found on the product when contacting Delta Consumer Experience Center.

Lorsque vous contactez le Service client de Delta, veuillez faire référence aux informations ci-dessus. Avant de contacter le Service client de Delta, veuillez vous assurer que les informations ci-dessus correspondent aux informations indiquées sur l'étiquette qui se trouve sur *panneau arrière*; veuillez faire référence aux informations indiquées sur le produit lorsque vous contactez le Service client de Delta.

Al contactar al servicio al cliente de Delta, entregue la información anteriormente mencionada. Antes de contactar al servicio de atención al cliente de Delta, asegúrese de que la información anteriormente mencionada calza con la que aparece en la etiqueta en *panel trasero*; al contactar al centro de atención al cliente de Delta, mencione la información que aparece en el producto.

**CONSUMER EXPERIENCE CENTER**

Delta Children's Products Corp | 114 West 26th Street New York, NY 10001  
(646) 435-8727 | [wcs@DeltaChildren.com](mailto:wcs@DeltaChildren.com) | [www.DeltaChildren.com](http://www.DeltaChildren.com)



# BABY SAFE SLEEP TIPS

Visit [Deltachildren.Com/Pages/Crib-Safety-Tips](https://Deltachildren.Com/Pages/Crib-Safety-Tips) for more information



Read all warnings and follow all instructions.



**DO NOT** place any items in the crib.



The safest place for your baby to sleep is in a JPMA Certified crib.



Pillows and blankets have caused infants to suffocate, **NEVER** use in a crib.

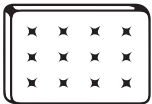

Your baby should sleep on a firm mattress.



**NEVER** place the crib near a window or any wall hangings.



Adult beds are not safe for babies: **NEVER** co-sleep.



Missing or broken parts, any questions? **CALL** Delta Children Consumer Care.



**AAP Recommends:** Always lay your baby on its back to sleep. Consult your doctor.





# FURNITURE SAFETY TIPS

Visit [Deltachildren.Com/Pages/Leaders-In-Safety](https://Deltachildren.Com/Pages/Leaders-In-Safety) for more information

**SERIOUS OR FATAL CRUSHING INJURIES  
CAN OCCUR FROM FURNITURE TIP-OVER.**



Read all warnings and follow all instructions.



**NEVER** open more than one drawer at a time.



**ALWAYS** use provided tipover restraints.



**DO NOT** leave drawers open when not in use.



**DO NOT** set TV's or other heavy objects on the top of bedroom or nursery furniture.



**NEVER** allow children to climb or hang on drawers, doors, or shelves.



Place heaviest items in the lowest drawers.



Missing or broken parts, any questions? **CALL** Delta Children Consumer Care.



# CONSEILS POUR FAIRE DORMIR VOTRE BÉBÉ EN TOUTE SÉCURITÉ

Visitez [Deltachildren.Com/Pages/Crib-Safety-Tips](http://Deltachildren.Com/Pages/Crib-Safety-Tips) pour plus d'information



Lisez tous les avertissements et respectez toutes les consignes de sécurité.



**NE** déposez aucun objet dans le Lit de Bébé



L'endroit le plus sûr pour faire dormir votre bébé, c'est dans un Lit de Bébé approuvé par JPMA.



Des oreillers et couvertures ont parfois été responsables d'étouffements de nourrissons. **N'** en utilisez **JAMAIS** dans un lit de bébé.



Votre bébé doit dormir sur un matelas ferme.



**NE** placez **JAMAIS** le Lit de Bébé à proximité d'une fenêtre ou de tentures.



Les lits d'adultes ne sont pas un lieu sûr pour les bébés: **NE** dormez **JAMAIS** ensemble.



Des pièces manquantes ou cassées? **APPELEZ** Delta Children Consumer Care.



**Conseils de l'AAP:** Placez toujours votre bébé sur le dos pour dormir. Consultez votre médecin.





# CONSEILS DE SÉCURITÉ RELATIFS AUX MEUBLES

Visitez [Deltachildren.Com/Pages/Leaders-In-Safety](http://Deltachildren.Com/Pages/Leaders-In-Safety) pour plus d'information

## LE RENVERSEMENT DU MEUBLE PEUT ENTRAÎNER DES BLESSURES GRAVES OU MORTELLES.



Lisez tous les avertissements et respectez toutes les consignes de sécurité.



**N'OUVREZ JAMAIS** plus d'un tiroir en même temps



Utilisez **TOUJOURS** les dispositifs de non-renversement fournis.



**NE** laissez **PAS** les tiroirs ouverts lorsque vous ne les utilisez pas.



**NE** déposez **PAS** de postes de télévision ou d'autres objets lourds sur des meubles de chambre à coucher ou de chambre d'enfants.



**NE** laissez **JAMAIS** les enfants monter sur ou se suspendre aux tiroirs, portes et ou tablettes.



Placez les objets les plus lourds dans les tiroirs du bas.



Des pièces manquantes ou cassées? **APPELEZ** Delta Children Consumer Care.



# CONSEJOS PARA UN SUEÑO SEGURO PARA LOS BEBÉS

Visite [Deltachildren.Com/Pages/Crib-Safety-Tips](http://Deltachildren.Com/Pages/Crib-Safety-Tips) para obtener más información



Lea todas las advertencias y siga todas las instrucciones.



**NO** coloque artículos en la cuna.



El lugar más seguro para que su bebé duerma es una cuna con certificación JPMA.



Las almohadas y frazadas han provocado asfixia en menores; por lo tanto, **JAMÁS** se deben utilizar en una cuna.



Su bebé debe dormir sobre un colchón firme.



**NEVER** place the crib near a window or any wall hangings.



Las camas para adultos no son seguras para los bebés: **JAMÁS** duerma con ellos.



¿Le faltan piezas o vienen rotas? **LLAME** al Delta Children Consumer Care.



**APP recomienda:** Haga que su bebé duerma siempre boca arriba. Consulte a su médico.





# CONSEJOS DE SEGURIDAD SOBRE MUEBLES

Visite [Deltachildren.Com/Pages/Leaders-In-Safety](http://Deltachildren.Com/Pages/Leaders-In-Safety) para obtener más información

**PUEDEN PRODUCIRSE LESIONES GRAVES O MORTALES POR APLASTAMIENTO AL VOLCARSE MUEBLES.**



Lea todas las advertencias y siga todas las instrucciones.

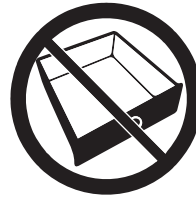

**NUNCA** abra más de un cajón al mismo tiempo.



Utilice **SIEMPRE** las retenciones contra volcamiento incluidas



**NO DEJE** cajones abiertos si no los está utilizando.



**NO** posicione televisores u otros objetos pesados sobre la cama o muebles para infantes.



**NUNCA** permita que los niños trepen sobre cajones, puertas o baldas de estantería ni que se cuelguen de ellos.



Coloque los artículos de mayor peso en los cajones inferiores.



¿Le faltan piezas o vienen rotas? **LLAME** al Delta Children Consumer Care.



# SAVE BIG WITH DELTA CHILDREN

Visit [Deltachildren.com](http://Deltachildren.com) To Start Shopping

Welcome to the  
**DELTA FAMILY**  
Here's a Gift From Us To You

# 10% OFF

Your Next Purchase From  
[DeltaChildren.com](http://DeltaChildren.com)

USE CODE:  
**DELTA10**

\*Exclusions Apply  
\*Subject to Change

## REVIEW TO WIN \$2500

### RULES TO ENTER



*"We LOVE, LOVE, LOVE this crib"*

My husband was impressed with the directions and organization of the hardware package. He easily assembled this crib in an hour without any help. It's very sturdy and we like that it has adjustable levels for the mattress height. To top it all off, it's so incredibly darling!!!

- 1** **WRITE A REVIEW** for this product on the store's website from where it was purchased
- 2** **TAKE A SCREENSHOT** of your review and upload it to [www.DeltaChildren.com/Review](http://www.DeltaChildren.com/Review)
- 3** **IT'S THAT EASY!** Upon submission, you'll be instantly **ENTERED TO WIN \$2,500**

#### FOLLOW US FOR MORE CHANCES TO WIN



@deltachildren

#### SCAN HERE



For more  
information &  
to see all of  
our products







# ÉCONOMISEZ BEAUCOUP AVEC AHORRE MUCHO CON DELTA CHILDREN

Visitez [Deltachildren.com](http://Deltachildren.com) Pour Commencer Vos Achats  
Visita [Deltachildren.com](http://Deltachildren.com) Para Comenzar A Comprar

Bienvenue dans la  
**FAMILLE DELTA**  
Voici Notre Cadeau Pour Vous  
Bienvenido a la  
**FAMILIA DELTA**  
Aquí Está Nuestro Regalo Para Usted

**10%  
OFF**

Votre Prochain Achat Chez  
Su Próxima Compra En  
[DeltaChildren.com](http://DeltaChildren.com)

UTILISEZ LE CODE:  
UTILICE EL CÓDIGO:  
**DELTA10**

\*Des exclusions s'appliquent  
\*Sujet à changement

\*Exclusions Apply  
\*Subject to Change

LAISSEZ UN COMMENTAIRE CLIENT POUR **GAGNER \$2500**  
CALIFIQUE EL PRODUCTO PARA **GANAR \$2500**

## REGLEMENT DE PARTICIPATION / REGLAS PARA PARTICIPAR

- 1** ECRIVEZ UN COMMENTAIRE CLIENT pour ce produit sur le site web du magasin où il a été acheté  
CALIFIQUE EL PRODUCTO en la página web de la tienda donde haya sido comprado
- 2** FAITES UNE CAPTURE D'ECRAN de votre commentaire client et mettez la en ligne sur [www.DeltaChildren.com/Review](http://www.DeltaChildren.com/Review)  
HAGA UNA CAPTURA DE PANTALLA de su calificación y cárguela a la pagina [www.DeltaChildren.com/Review](http://www.DeltaChildren.com/Review)
- 3** C'EST AUSSI SIMPLE QUE ÇA! Dès que c'est fait vous serez instantanément **INSCRIT POUR GAGNER 2500\$**  
ES ASÍ DE FÁCIL! En cuanto lo envíe ya estará instantáneamente **PARTICIPANDO PARA GANAR \$2.500**

SUIVEZ NOUS POUR AVOIR PLUS DE CHANCES DE GAGNER /  
SÍGANOS PARA TENER MAS CHANCES DE GANAR



@deltachildren

SCANNEZ ICI / ESCANEE AQUÍ



Pour plus d'informations et  
pour voir tous nos produits

Para más información y para  
ver todos nuestros productos



## **⚠ WARNING**



**Children have died from furniture tipover. To reduce the risk of furniture tipover:**

- ALWAYS install tipover restraint provided.
- NEVER put a TV on this product.
- NEVER allow children to stand, climb or hang on drawers, doors, or shelves.
- NEVER open more than one drawer at a time.
- Place heaviest items in the lowest drawers.



## **⚠ AVERTISSEMENT**



**Des enfants sont morts à cause d'un meuble qui se renverse. Pour aider à prévenir un renversement :**

- Installez TOUJOURS le système anti-bascule fourni.
- Ne JAMAIS placer un téléviseur sur ce produit.
- Ne jamais permettre à un enfant de grimper ou s'accrocher aux tiroirs, portes ou étagères.
- Ne jamais ouvrir plus d'un tiroir à la fois
- Placez les articles les plus lourds dans les tiroirs inférieurs.



## **⚠ ADVERTENCIA**



**Han muerto niños debido a volcaduras de muebles. Para prevenir volcaduras:**

- Instalar SIEMPRE el dispositivo anti-volcaduras incluido.
- No colocar NUNCA un televisor en este producto.
- Nunca permita que los niños trepen sobre cajones, puertas o baldas de estantería ni que se cuelguen de ellos.
- Nunca abra más de un cajón al mismo tiempo.
- Coloque los artículos de mayor peso en los cajones inferiores.



#### NOTES ON ASSEMBLY:

-During the assembly process whenever using screws or bolts, check each by placing the screw/bolt on the diagram of the item which is drawn actual size and design. Be sure to use the proper size and shape specified in the instructions.

-To assemble this unit you may be required to place the unit on it's side and face. It is strongly recommended that assembly is done on a soft, non-abrasive surface to avoid damaging the finish.

#### NOTES ON CARE AND MAINTENANCE:

- **Do not** scratch or chip the finish.

- Inspect the product periodically, contact Delta Children's Products for replacement parts or questions.

- **Do not** store the product or any parts in extreme temperatures and conditions such as a hot attic or a damp, cold basement. These extremes can cause a loss of structural integrity.

-To preserve the luster of the high quality finish on your product, it is recommended to place a doily or felt pad under any items you place on the finish.

-Clean with a damp cloth, then a dry cloth to preserve the original luster and beauty of this fine finish.

-**Do not** use abrasive chemicals.

-**Do not** spray cleaners directly onto furniture.

-Lift slightly when moving on carpeting to prevent leg breakage.

-Use of a vaporizer near furniture will cause wood to swell and finish to peel.

---

#### REMARQUES SUR L'ASSEMBLAGE :

-Lors de l'assemblage, quand vous utilisez vis ou boulons, vérifiez chaque pièce en plaçant le vis/boulon sur le diagramme de la pièce concernée qui est dessinée en taille et forme réelle. Assurez-vous d'utiliser la taille et la forme exacte comme il est spécifié dans les instructions.

-Pour assembler cet élément vous pourriez avoir besoin de le placer sur le côté latéral et sur le côté frontal. Il est fortement recommandé de faire l'assemblage sur une surface lisse, non abrasive (comme le film mousse de l'emballage) pour éviter d'endommager les finitions.

#### REMARQUES SUR LE SOIN ET L'ENTRETIEN:

-**Ne pas** rayer ou ébrécher la finition.

-Examinez de près le produit régulièrement, contactez Delta Children's Products pour les pièces de rechange ou pour poser des questions.

-**Ne pas** ranger le produit ou des pièces à des températures extrêmes ou dans des conditions comme un grenier chaud ou une cave froide et humide. Ces extrêmes peuvent causer une perte de l'intégrité de la structure du produit

-Pour préserver le lustre original et la beauté de ce fini raffiné nettoyez avec un chiffon humide, puis un chiffon sec.

-**Ne pas** utiliser des produits chimiques abrasifs

-**Ne pas** pulvériser un nettoyant directement sur le meuble, pulvériser sur le torchon et puis appliquer sur le meuble. Testez le produit nettoyant sur un endroit discret avant de l'utiliser sur la totalité du meuble

-Lors d'un déplacement sur une moquette ou tapis, soulevez légèrement le meuble pour éviter de casser les pieds.

-L'utilisation d'un vaporisateur près du meuble causera le gonflement du bois et l'écaillage de la finition.

---

#### INFORMACIÓN SOBRE EL MONTAJE:

-Durante el proceso de montaje, ya utilice pernos o tornillos, compruebe cada uno de ellos colocando el perno/tornillo en el diagrama del artículo donde está dibujado el tamaño y el diseño real. Asegúrese de que utiliza el tamaño y la forma adecuada que especifican las instrucciones.

-Para montar esta unidad, puede que se le solicite que coloque la unidad de lado y de cara. Se recomienda encarecidamente que realice el montaje sobre una superficie no abrasiva (Como la envoltura de embalaje de espuma) para evitar dañar el acabado.

#### NOTAS SOBRE SU CUIDADO Y MANTENIMIENTO:

- **No** arañe ni desconche el acabado.

- Inspeccione el producto con regularidad, póngase en contacto con Delta Children's Products para el recambio de partes o para formular preguntas.

- **No** guarde el producto ni ninguna de sus partes a temperaturas ni en condiciones extremas como un ático caluroso o un sótano húmedo y frío. Estos extremos pueden provocar una pérdida de integridad estructural.

-Para preservar el brillo del acabado de alta calidad que recubre su producto, se recomienda que coloque un paño o una almohadilla de fieltro debajo de cualquier objeto que coloque sobre el acabado.

-Límpielo con un trapo húmedo y luego con uno seco para preservar el brillo y la belleza originales de este fino acabado.

-**No** utilice productos químicos abrasivos.

-**No** pulverice limpiadores directamente sobre el mueble.

-Elevéelo ligeramente cuando lo mueva sobre alfombras o moqueta para evitar que se rompan las patas.

-El uso de vaporizadores cerca de muebles puede provocar que la madera se hinche y acabe desconchándose.



PARTS: MAKE SURE THAT ALL PRE-ASSEMBLED PARTS ARE TIGHT  
 PIÈCES : VÉRIFIEZ QUE TOUTES LES PIÈCES PRÉ-MONTÉES SONT BIEN SERRÉES.  
 PIEZAS: ASEGÚRESE DE QUE TODAS LAS PIEZAS PRE-ENSAMBLADAS ESTÁN BIEN APRETADAS.

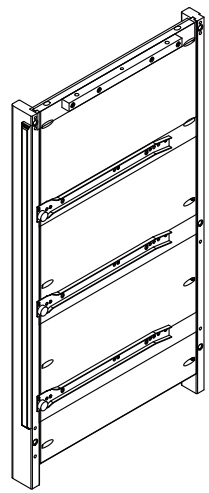

B. Left Side x1  
Côté gauche  
Lado izquierdo  
#40108

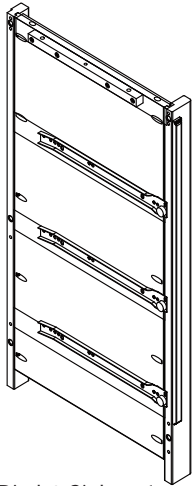

C. Right Side x1  
Côté droit  
Lado derecho  
#40109

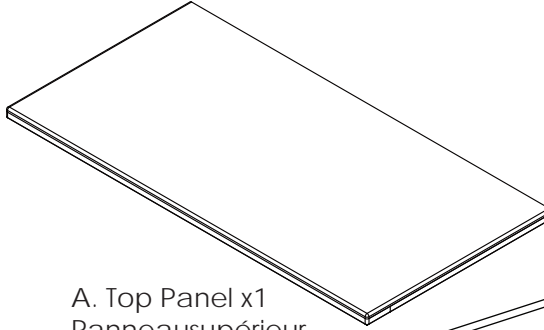

A. Top Panel x1  
Panneau supérieur  
Panel superior  
#40110

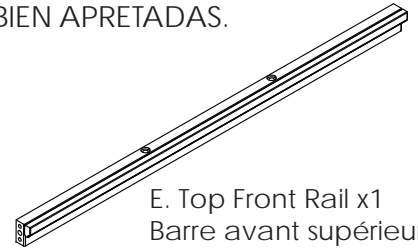

E. Top Front Rail x1  
Barre avant supérieur  
Barra frontal superior  
#40111

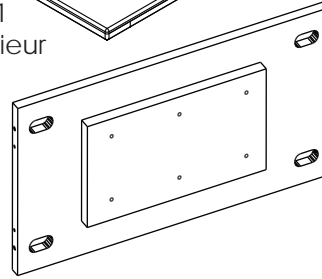

D. Bottom Back Rail x1  
Barre arrière inférieur  
Barra trasero inferior  
#40114

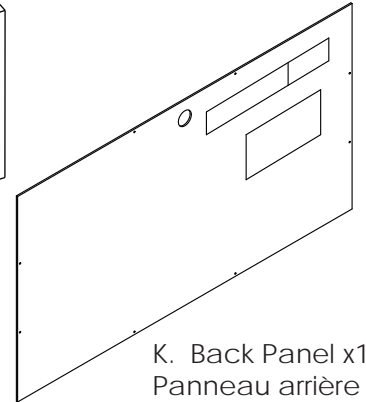

K. Back Panel x1  
Panneau arrière  
Panel trasero  
#40115

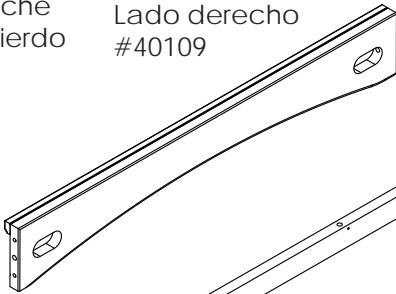

T. Bottom Front Rail x1  
Barre avant inférieur  
Barra frontal inferior  
#40112

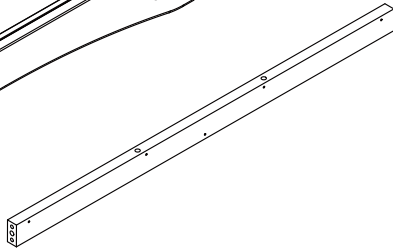

F. Top Back Rail x1  
Barre arrière supérieur  
Barra trasero superior  
#40113

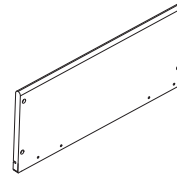

U. Drawer Side x6  
Barre de tiroir  
Barra de la gaveta  
#40117

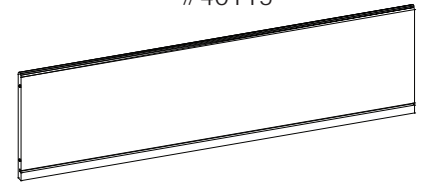

P. Drawer Back x3  
Arrière du tiroir  
Trasera de la gaveta  
#40119

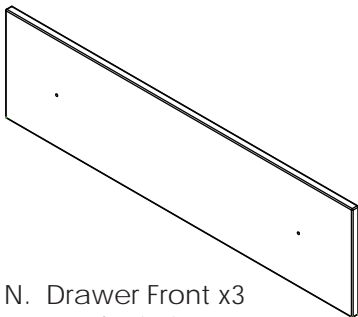

N. Drawer Front x3  
Avant du tiroir  
Parte frontal de la gaveta  
#40116

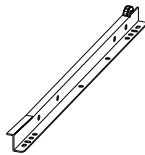

G. Left Drawer Guide x3  
Glissière de tiroir gauche  
Guía de gaveta izquierda  
#5766



H. Right Drawer Guide x3  
Glissière de tiroir droite  
Guía de gaveta derecha  
#5767

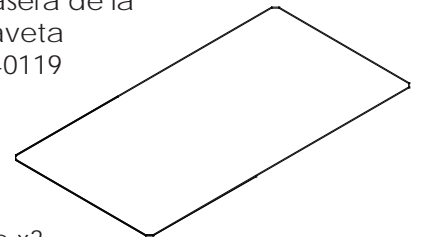

S. Drawer Bottom x3  
Fond du tiroir  
Fondo de la gaveta  
#40120

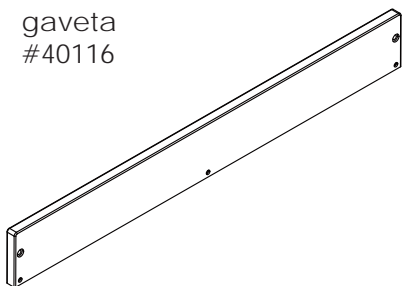

Y. Changing Top Back x1  
Partie postérieure du plan à langer  
Parte posterior del cambiador  
#40121

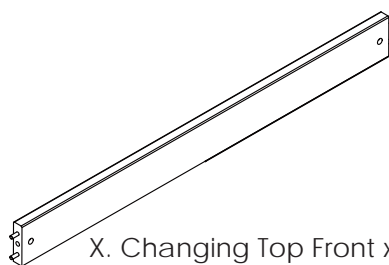

X. Changing Top Front x1  
Partie frontale du plan à langer  
Parte frontal del cambiador  
#40122

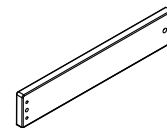

V. Changing Top Left Side x1  
Côté gauche du plan à langer  
Lado izquierdo del cambiador  
#40123

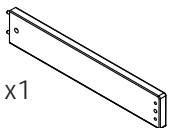

W. Changing Top Right side x1  
Côté droit du plan à langer  
Lado derecho del cambiador  
#40124





Parts: Hardware kits part#40125

Pièces: L'ensemble de quincaillerie - pièce n°40125

Piezas: El kit de herramientas - Pieza #40125

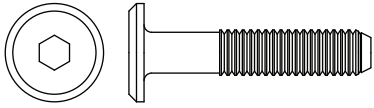
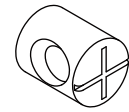

GG. 30mm Bolt x4  
Boulon 30mm  
Perno 30mm

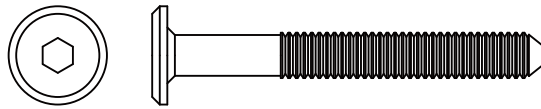

CC. 50mm Bolt x18  
Boulon 50mm  
Perno 50mm

KK. Plastic Barrel Nut x12  
Écrou à portée cylindrique en plastique  
Tuerca cilíndrica plástica

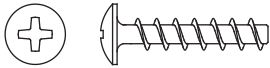

LL. 20mm Screw x12  
Vis 20mm  
Tornillo 20mm

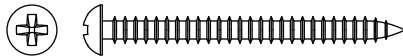

NN. 40mm Screw x15  
Vis 40mm  
Tornillo 40mm

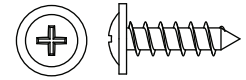

EE. Back Panel Screw x12  
Vis pour Panneau Arrière  
Tornillo de Panel Trasero



MM. Barrel Nut x4  
Écrou à portée cylindrique  
Tuerca cilíndrica

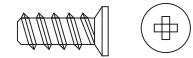

AA. 12mm Screw x12  
Vis 12mm  
Tornillo 12mm

PP. Knob / Bouton / Perilla x6  
#40127



PP2. Knob Screw  
Vis de Bouton  
Tornillo para Perilla

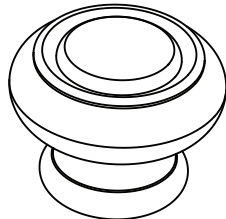

PP1. Knob  
Bouton  
Perilla

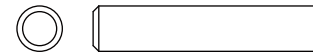

FF. M6x30mm Wood Dowel x18  
Cheville en Bois M6x30mm  
Pasador de Madera M6x30mm

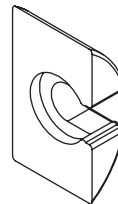

BB. Crescent Washer x10  
Rondelle en croissant  
Arandela de media luna

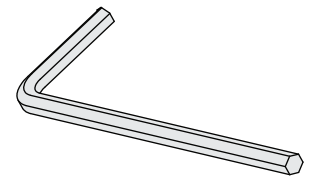

M4 Allen Wrench (included)  
Clé Allen M4 (inclus)  
Llave Allen M4 (incluido)

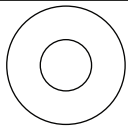

TT. Washer x2  
Rondelle  
Arandela



ZZ. (1) Wall Strap/Sangle murale/Abrazadera

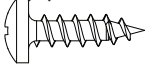

YY. Short Screw x1  
Vis Court  
Tornillo corto

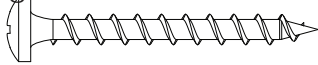

XX. Long Screw x1  
Vis Longue  
Tornillo Largo

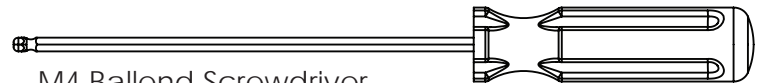

M4 Ballend Screwdriver  
tournevis M4 à tête sphérique  
destornillador M4 con cabeza de bola

**CAUTION: Do Not use a power screwdriver they can cause screws to break or strip.**

**ATTENTION: Ne Pas utiliser un tournevis électrique car les vis peuvent casser ou perdre leurs filets.**

**ATENCIÓN: No use un destornillador eléctrico ya que puede causar que los tornillos se rompan o rueden.**

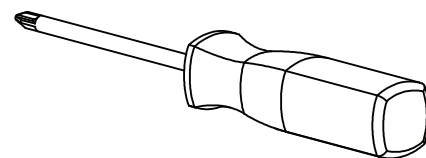
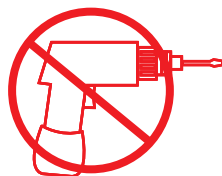

Phillips Screwdriver – Not included  
Tournevis Phillips - non inclus  
Destornillador Phillips – no incluido





**Hardware System - Review Before Assembly**  
**Quincaillerie – Lire Avant D’effectuer Le Montage**  
**Revise Antes De Armar- Elementos De Fijacion Y Ensamble**

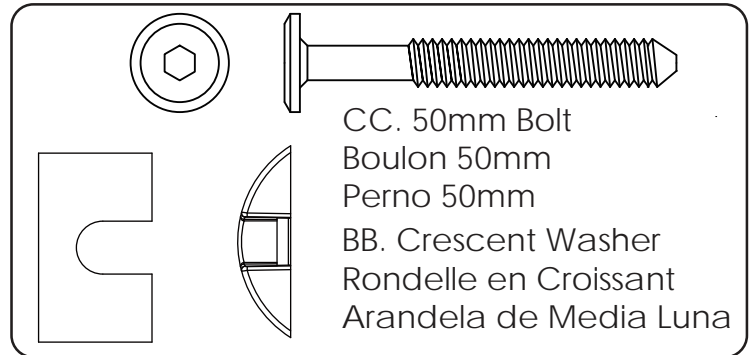
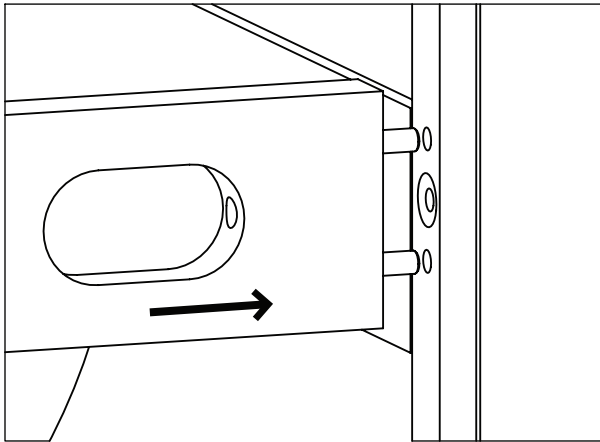

1. Insert the Dowels in the Rail into the holes in the Post.
1. Insérer les chevilles dans le rail dans les orifices dans le poteau.
1. Inserte los pasadores del Riel en los agujeros del Poste.

2. Insert the Bolt into the slot. Turn clockwise with fingers or the Ball End Screwdriver provided. DO NOT fully tighten, leave 1/2" (12mm) exposed.

2. Insérez le boulon dans la fente. Tournez dans le sens des aiguilles d’une montre à l’aide des doigts ou de la tournevis à tête sphérique. Ne Pas serrer complètement et laissez 12 mm (1/2 pouces) exposés.

2. Inserte el perno en la ranura. Gírelo en el sentido de las agujas del reloj con los dedos o con el destornillador con cabeza de bola. NO lo apriete del todo, deje 1/2" (12 mm) fuera.

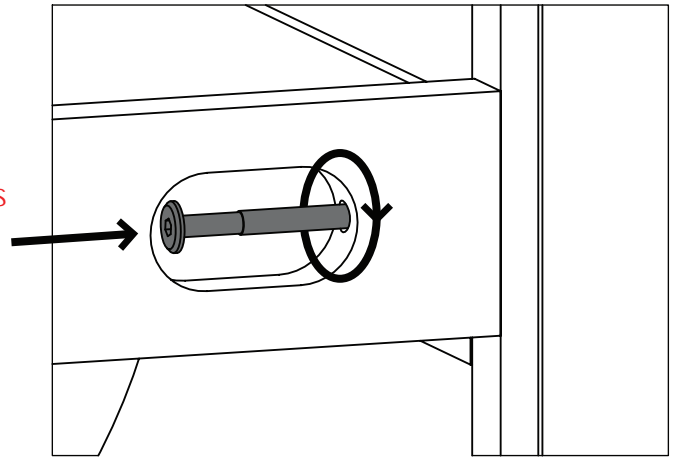

3. Slide the Crescent Washer over the exposed bolt, behind the head of the bolt.

3. Glissez la rondelle en croissant sur l’écrou exposé, derrière la tête de l’écrou.

3. Abrace la parte del Perno que quedó fuera, debajo de la cabeza del mismo, con la Arandela de media luna.

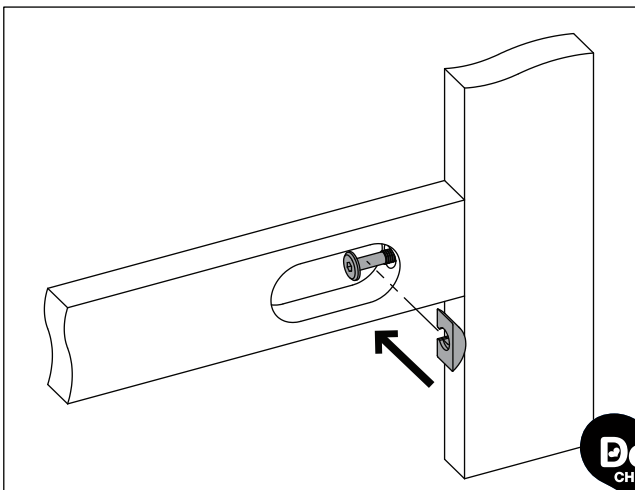



Install (1) bolt and (1) crescent washer at a time. Tighten until it looks like the picture.

Installez (1) boulon et (1) rondelle en croissant à la fois. Serrez jusqu'à ce que cela ressemble à l'image.

Instale (1) perno y (1) Arandela de media luna al mismo tiempo. Apriételos hasta que quede como en la ilustración.

Tighten the bolt with the ball end screwdriver.  
Serrez à l'aide de la Tournevis à tête sphérique.  
Apriételo con el Destornillador hcon cabeza de bola.

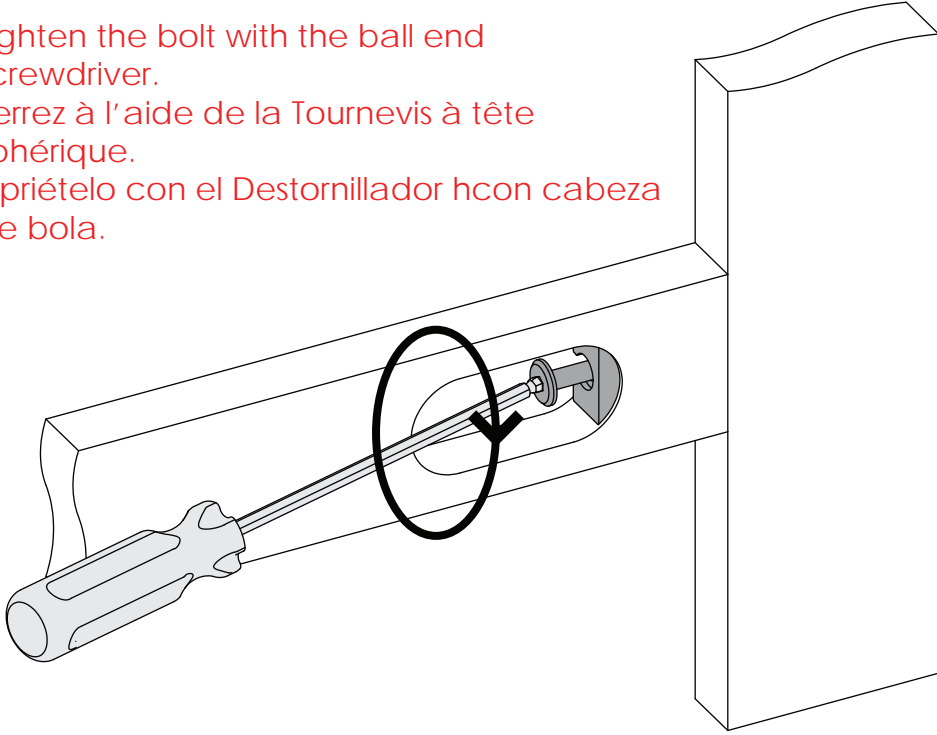

Ensure all bolts are tight with Allen wrench.  
Serrez à l'aide de la clé Allen.  
Apriételo con la llave Allen.

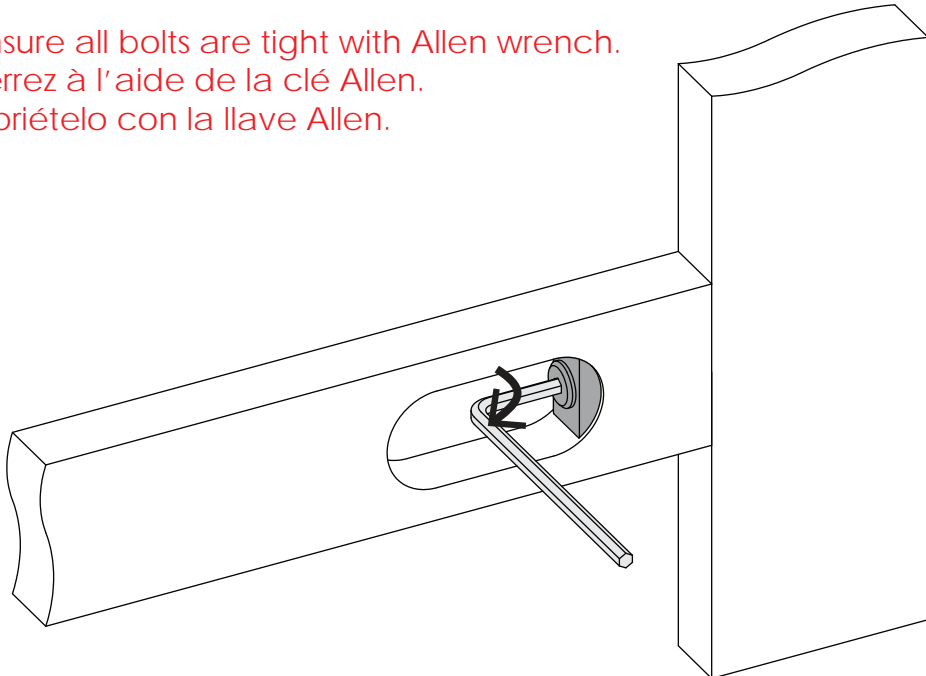



Step 1  
Étape 1  
Paso 1

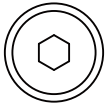

CC.50mm Bolt x5  
Boulon 50mm  
Perno 50mm

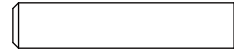

FF. M6x30mm Wood Dowel x8  
Cheville en Bois M6x30mm  
Pasador de Madera M6x30mm



BB. Crescent Washer x5  
Rondelle en croissant  
Arandela de media luna



M4 Ballend Screwdriver  
tournevis M4 à tête sphérique  
destornillador M4 con cabeza de bola

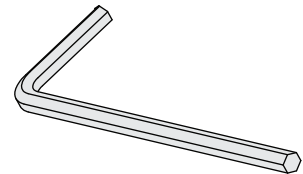

M4 Allen Wrench (included)  
Clé Allen M4 (inclus)  
Llave Allen M4 (incluido)

Attach Bottom Front Rail (Part T), Bottom Back Rail (Part D), Top Front Rail (Part E) and Top Back Rail (Part F) to Left Side (Part B) using (5) 50mm bolts (Part CC), (5) Crescent Washer (Part BB) and (8) 30mm Dowels (Part FF). Tighten the Bolts with the M4 Ballend Screwdriver and M4 Allen wrench, following the instructions on pages 14 and 15.

Fixer le Barre avant inférieur (Pièce T), Barre arrière inférieur (Pièce D), Barre Supérieur avant (Pièce E) et Barre Supérieur Arrière (Pièce F) au Côté gauche (Pièce B) à l'aide de (5) boulons de 50mm (Pièce CC), (5) Rondelle en croissant (Pièce BB) et (8) Chevilles 30mm (Pièce FF) à l'aide de dutournevis M4 à tête sphériqueet la clé Allen M4 ensuivant les instructions pages 14 et 15.

Fije la Barra frontal inferior (Pieza T), Barra trasero inferior (Pieza D), Barra Frontal Superior (Pieza E) y Barra Posterior Superior (Pieza F) al Lado izquierdo (Pieza B) utilizando (5) Pernos 50mm (Pieza CC), (5) Arandela de media luna (Pieza BB) y (8) Pasadors 30mm (Pieza FF) utilizando el destornillador M4 con cabeza de bola y la llave Allen M4 siguiendo las instrucciones de las páginas 14 y 15.





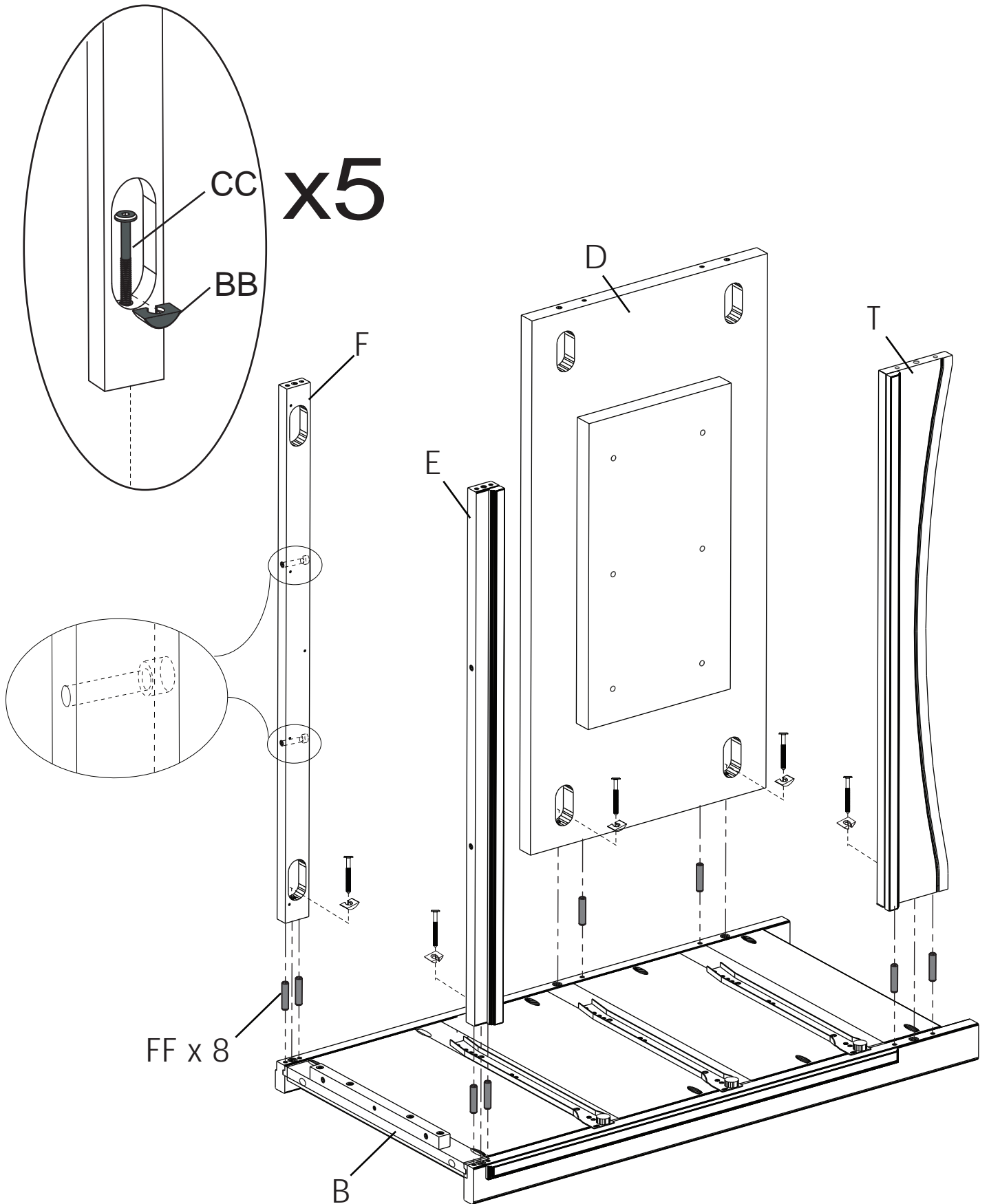



Step 2  
Étape 2  
Paso 2

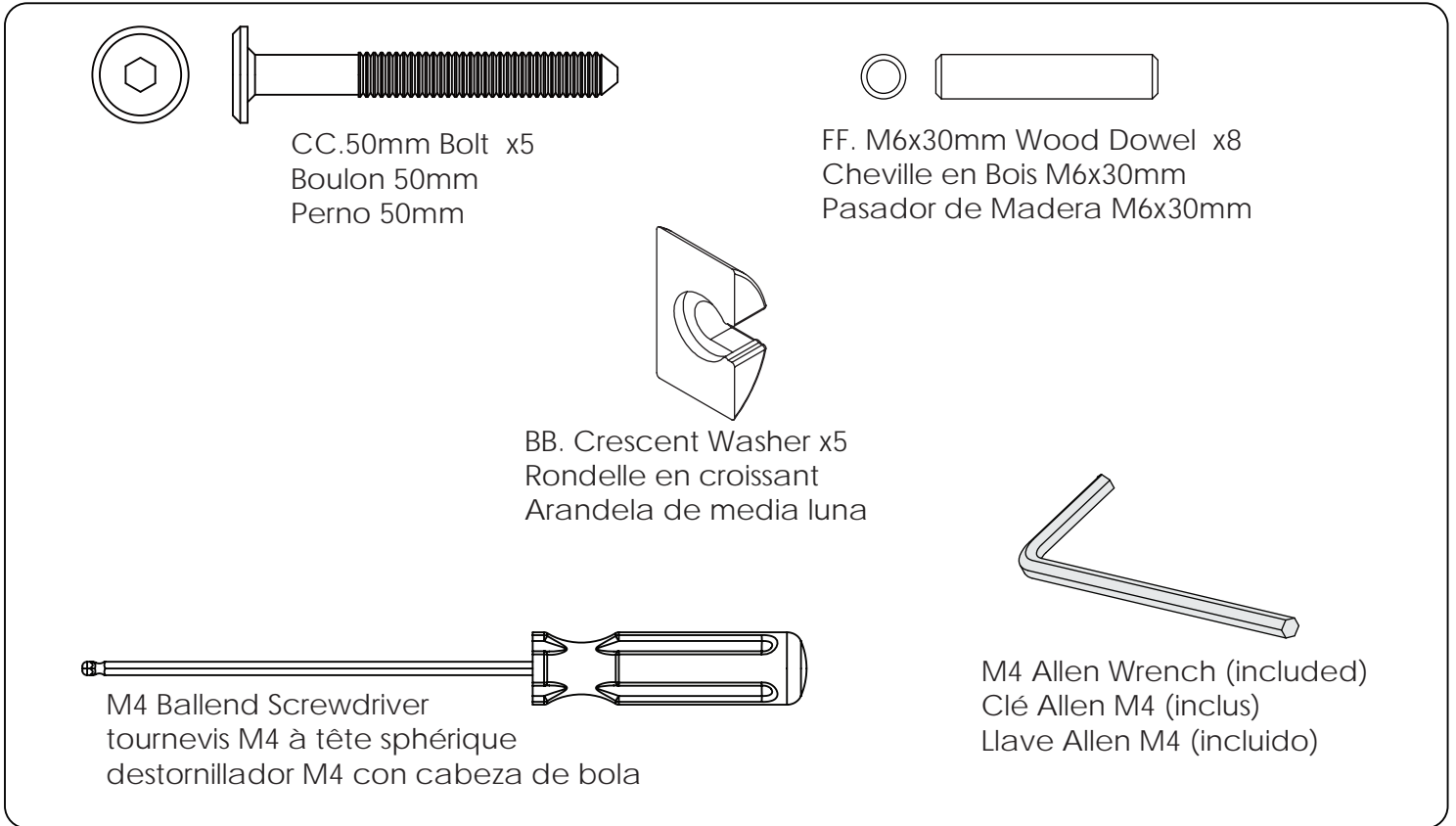

Attach the Right Side (Part C) using (5) 50mm bolts (Part CC), (5) Crescent Washer (Part BB) and (8) 30mm Dowels (Part FF). Tighten the Bolts with the M4 Ballend Screwdriver and M4 Allen wrench, following the instructions on pages 14 and 15.

Fixez le côté droit (pièce C) à l'aide de (5) boulons de 50mm (Pièce CC), (5) Rondelle en croissant (Pièce BB) et (8) Chevilles 30mm (Pièce FF) à l'aide de dutournevis M4 à tête sphériqueet la clé Allen M4 ensuivant les instructions pages 14 et 15.

Fije el lado derecho (Pieza C) utilizando (5) Pernos 50mm (Pieza CC), (5) Arandela de media luna (Pieza BB) y (8) Pasadors 30mm (Pieza FF) utilizando el destornillador M4 con cabeza de bola y la llave Allen M4 siguiendo las instrucciones de laspáginas 14 y 15.

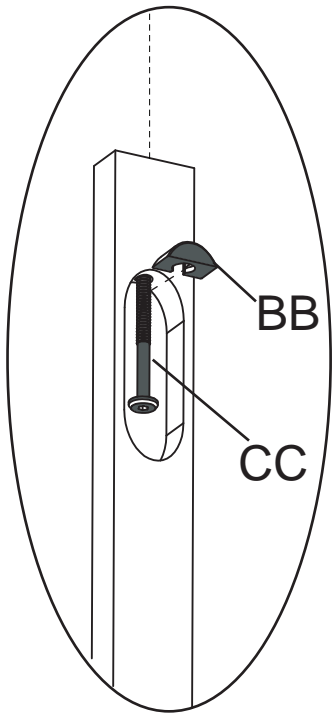

x5

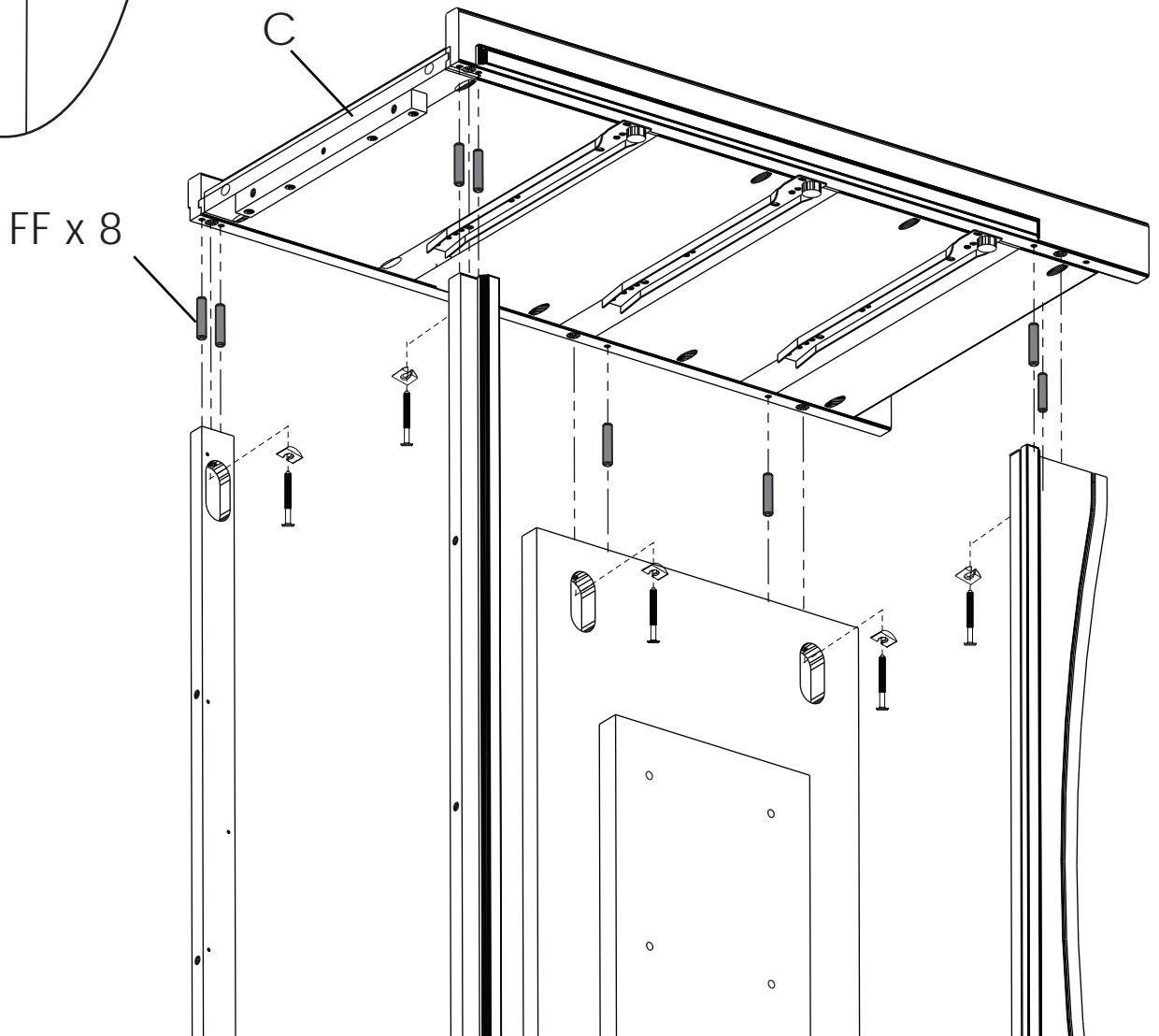



Step 3  
Étape 3  
Paso 3

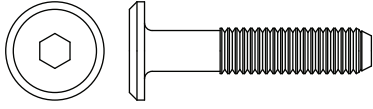

GG. 30mm Bolt x4  
Boulon 30mm  
Perno 30mm

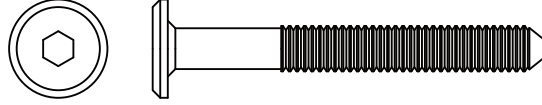

CC.50mm Bolt x4  
Boulon 50mm  
Perno 50mm

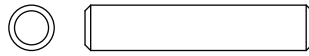

FF. M6x30mm Wood Dowel x2  
Cheville en Bois M6x30mm  
Pasador de Madera M6x30mm



M4 Ballend Screwdriver  
tournevis M4 à tête sphérique  
destornillador M4 con cabeza de bola

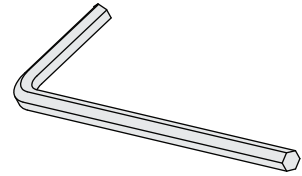

M4 Allen Wrench (included)  
Clé Allen M4 (inclus)  
Llave Allen M4 (incluido)

Attach the Top Panel (Part A) to the assembly from Step 2 using (2) 30mm Dowels (Part FF), (4) 50mm Bolts (Part CC) and (4) 30mm Bolts (Part GG). Tighten the Bolts with the M4 Ballend Screwdriver and M4 Allen wrench.

Fixer le Panneau Avant (Pièce A) au montage assemblé à l'étape 2 à l'aide de (2) Chevilles 30mm (Pièce FF), (4) Boulons 50mm (Pièce CC) et (4) Boulons 30 mm (Pièce GG) à l'aide de du tournevis M4 à tête sphérique et la clé Allen M4.

Fije el Panel Superior (Pieza A) al ensamblaje del Paso 2 utilizando (2) Pasadors 30mm (Pieza FF), (4) Pernos 50mm (Pieza CC) y (4) Pernos 30 mm (Pieza GG) utilizando el destornillador M4 con cabeza de bola y la llave Allen M4.

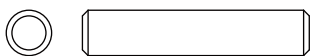

FF. M6x30mm Wood Dowel x2  
Cheville en Bois M6x30mm  
Pasador de Madera M6x30mm

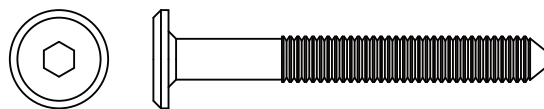

CC.50mm Bolt x4  
Boulon 50mm  
Perno 50mm

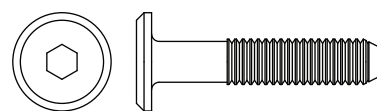
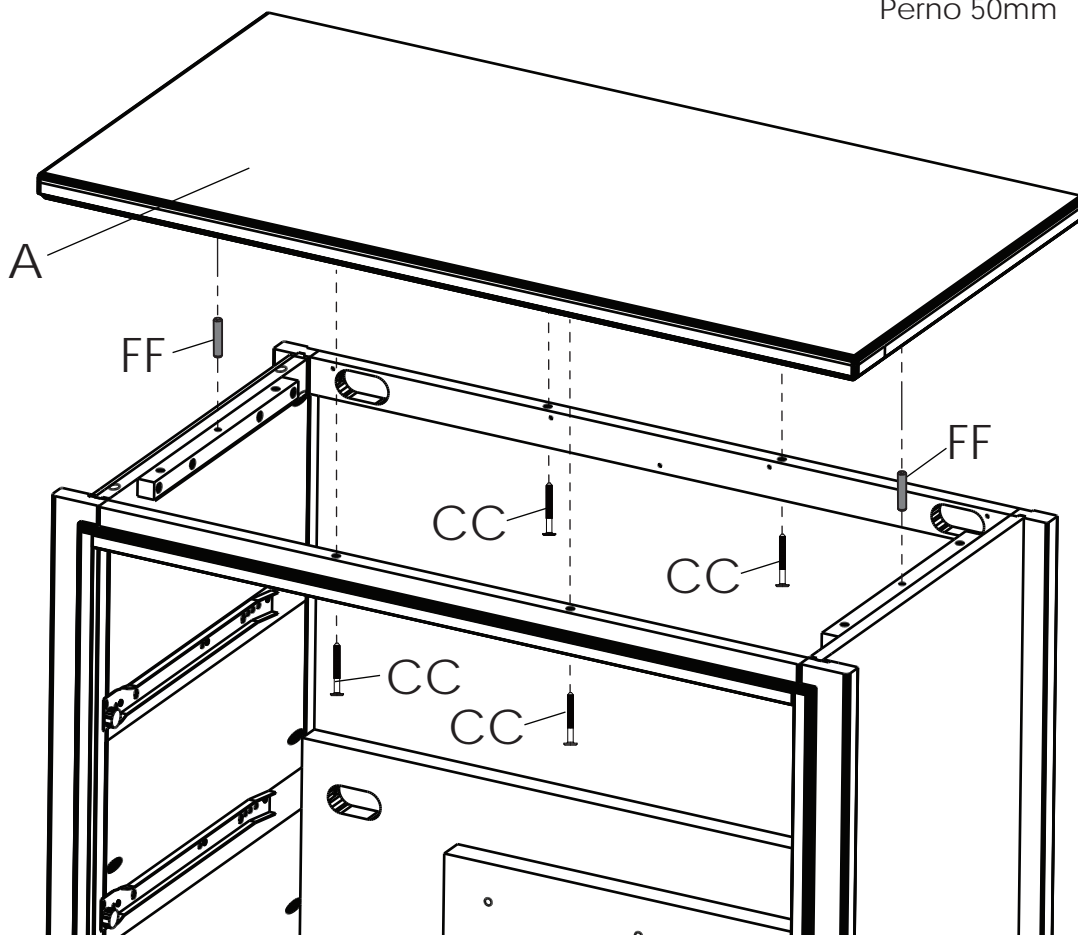

GG. 30mm Bolt x4  
Boulon 30mm  
Perno 30mm

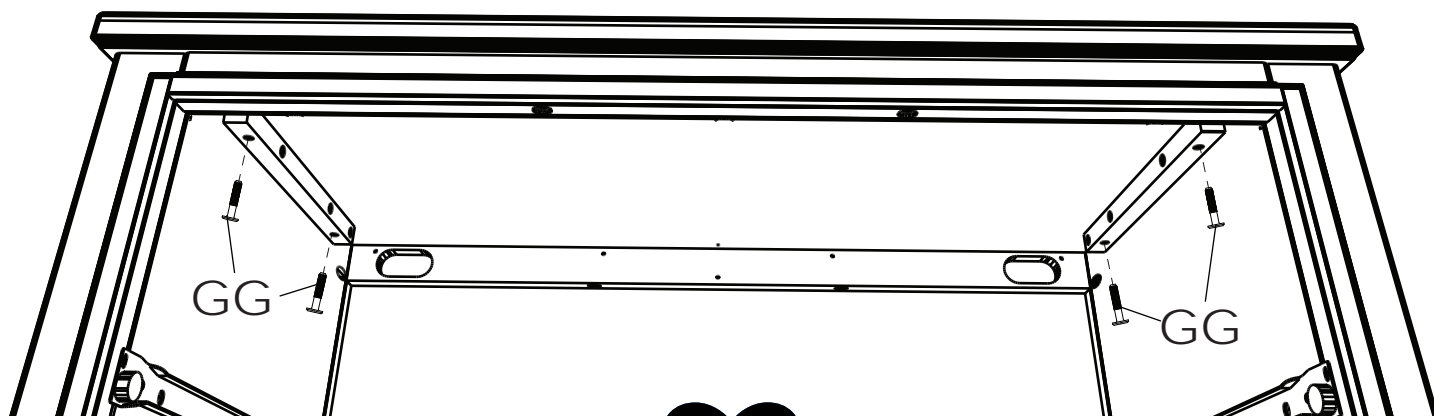



Step 4  
Étape 4  
Paso 4

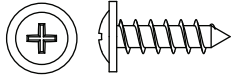

EE. Back Panel Screw x12  
Vis pour Panneau Arrière  
Tornillo de Panel Trasero

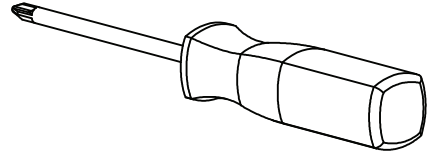

Phillips Screwdriver – Not included  
Tournevis Phillips - non inclus  
Destornillador Phillips – no incluido

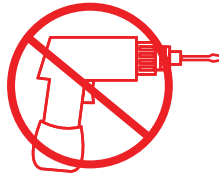

**CAUTION:** Do Not use a power screwdriver they can cause screws to break or strip.  
**ATTENTION:** Ne Pas utiliser un tournevis électrique car les vis peuvent casser ou perdre leurs filets.  
**ATENCIÓN:** No use un destornillador eléctrico ya que puede causar que los tornillos se rompan o rueden.

Attach Back Panel (Part K) using (12) Screws (Part EE), tighten with a Phillips screwdriver.

Fixez le panneau arrière (Pièce K) à l'aide de (12) vis (Pièce EE), serrez à l'aide d'un tournevis cruciforme.

Una el panel posterior (Pieza K) utilizando (12) tornillos (Pieza EE), apriete utilizando un destornillador Philips.



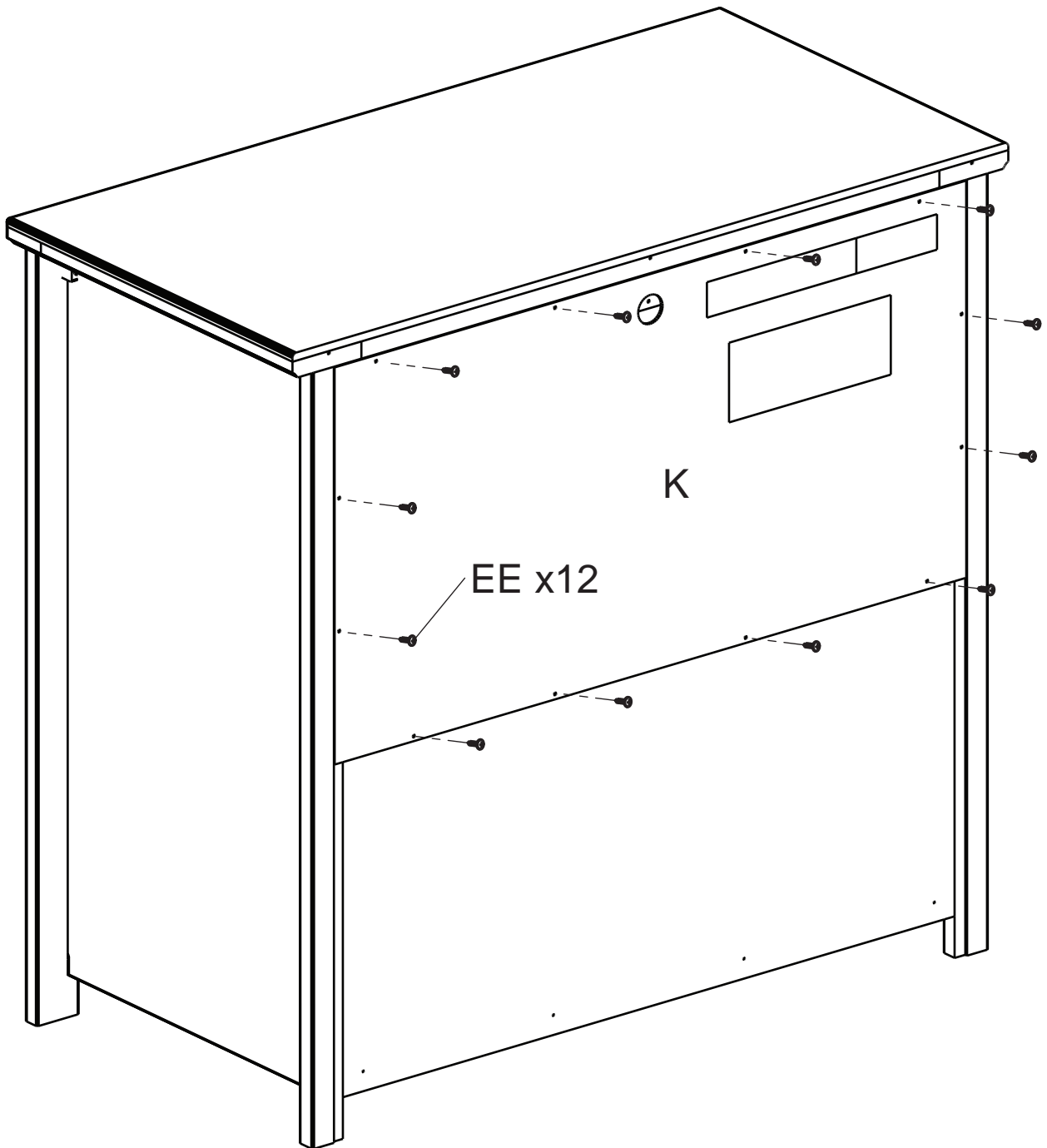



Step 5  
Étape 5  
Paso 5

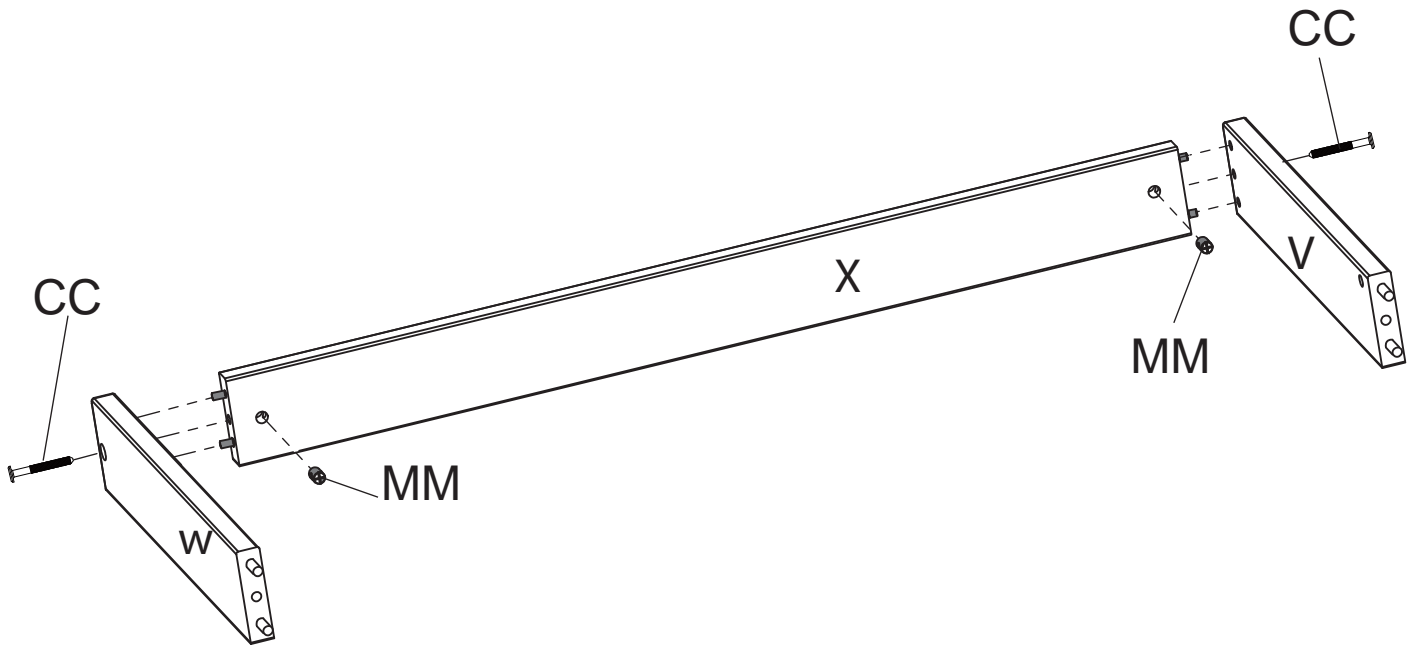
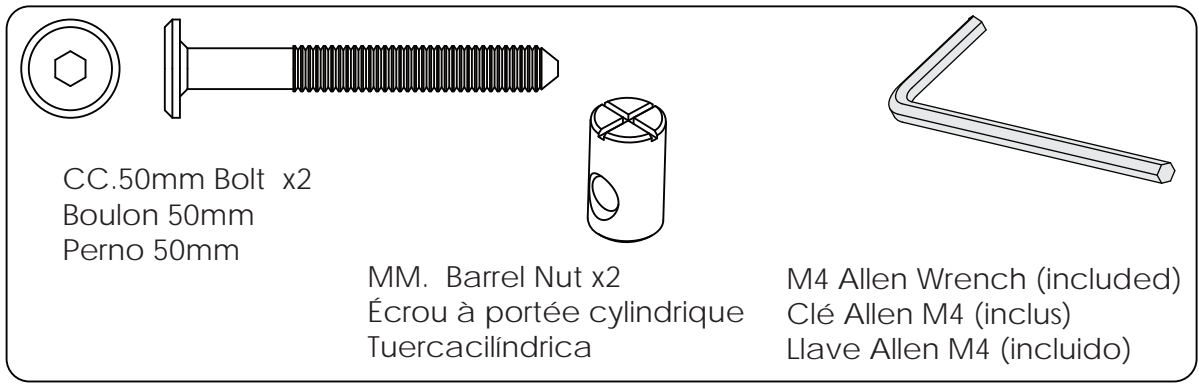

1. Attach Changing Top Right Side (Part W) to the Changing Top Front (Part X) using (1) M6x50mm bolt (part CC) and (1) Barrel Nut (Part MM) . Tighten using M4 allen wrench.
2. Attach Changing Top Left Side (Part V) in the same manner

1. Fixer le coté droit du plan à langer (Pièce W) à la partie frontale du plan à langer (Pièce X) à l'aide de (1) boulon M6 x 50mm (Pièce CC) et d' (1) Écrou à portée cylindrique (Pièce MM). Serrez avec la Clé Allen.
2. Fixer le coté gauche du plan à langer (Pièce V) de la même façon.

1. Fijar el lado derecho del cambiador (pieza W) con la parte frontal del cambiador (pieza X) utilizando (1) Tuercacilíndrica (Pieza MM) and (1) perno de 50mm (pieza CC). Apriete con la Llave Allen.
2. Fijar el lado izquierdo del cambiador (pieza V) de la misma manera.





Step 6  
Étape 6  
Paso 6

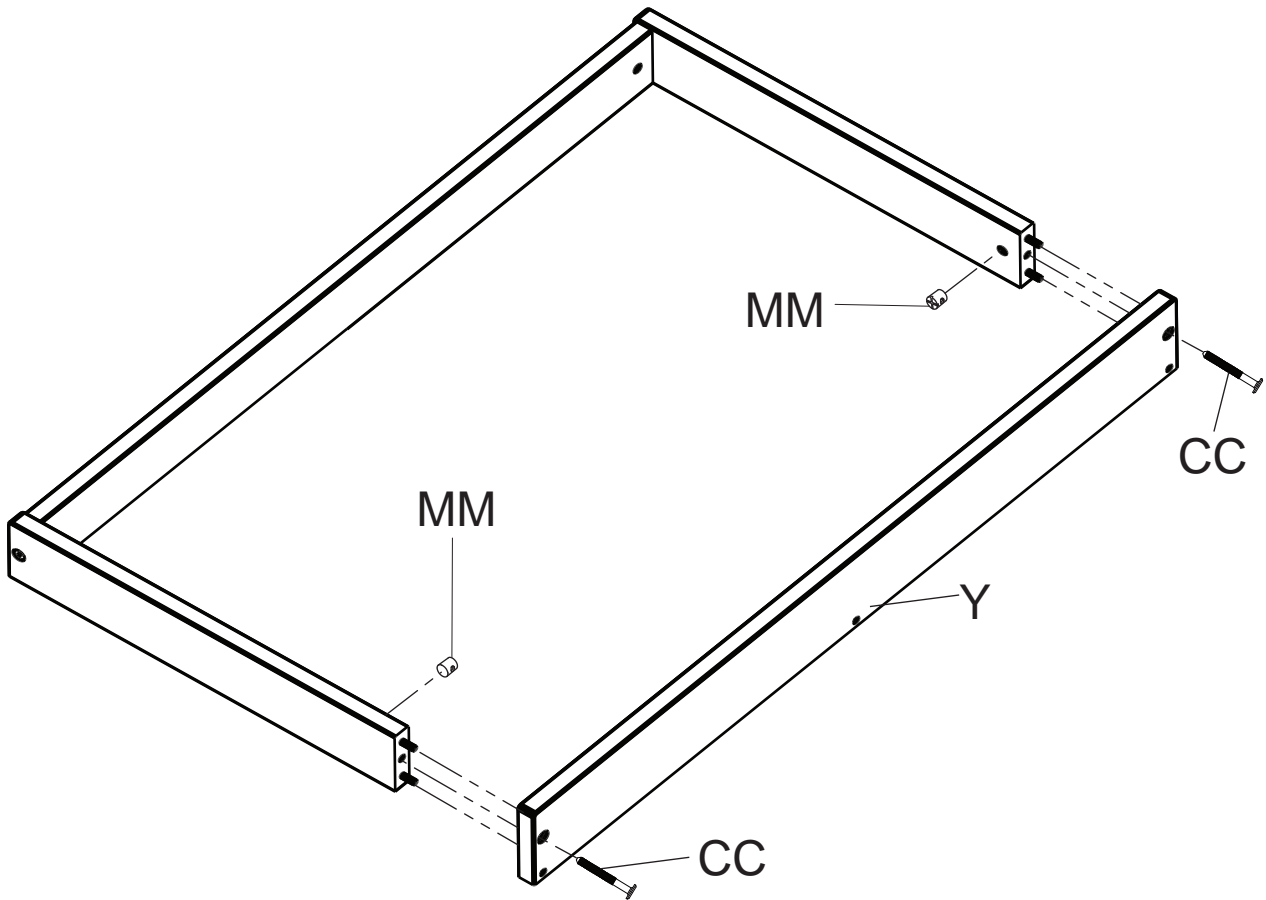
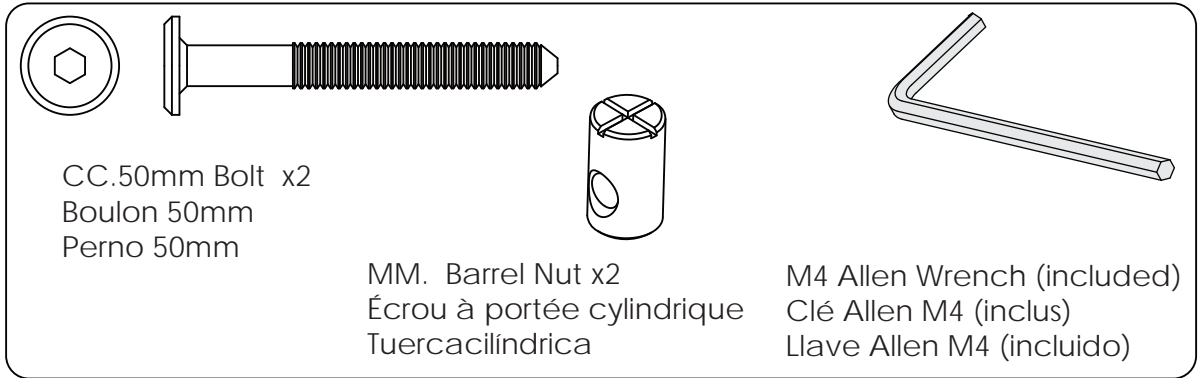

Attach Changing Top Back (Part Y) to the Right and Left Sides using using (2) M6x50mm bolts (part CC) and (2) Barrel Nuts (Part MM) . Tighten with the Allen Wrench.

Fixer la partie postérieure du plan à l'angier (Pièce Y) au cotés droit et gauche à l'aide de (2) boulons M6 x 50mm (Pièce CC) et d'(2) Écrou à portée cylindrique (Pièce MM). Serrezavec la Clé Allen.

Fijar la parte posterior del cambiador (Pieza Y) a los lados derecho e izquierdo utilizando (2) Tuerca cilíndrica (Pieza MM) and (2) pernos de 50mm (pieza CC). Apriete con la Llave Allen.



Step 7  
Étape 7  
Paso 7

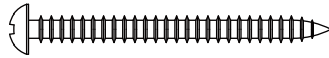

NN. 40mm Screw x3  
Vis 40mm  
Tornillo 40mm

Phillips Screwdriver – Not included  
Tournevis Phillips - non inclus  
Destornillador Phillips – no incluido

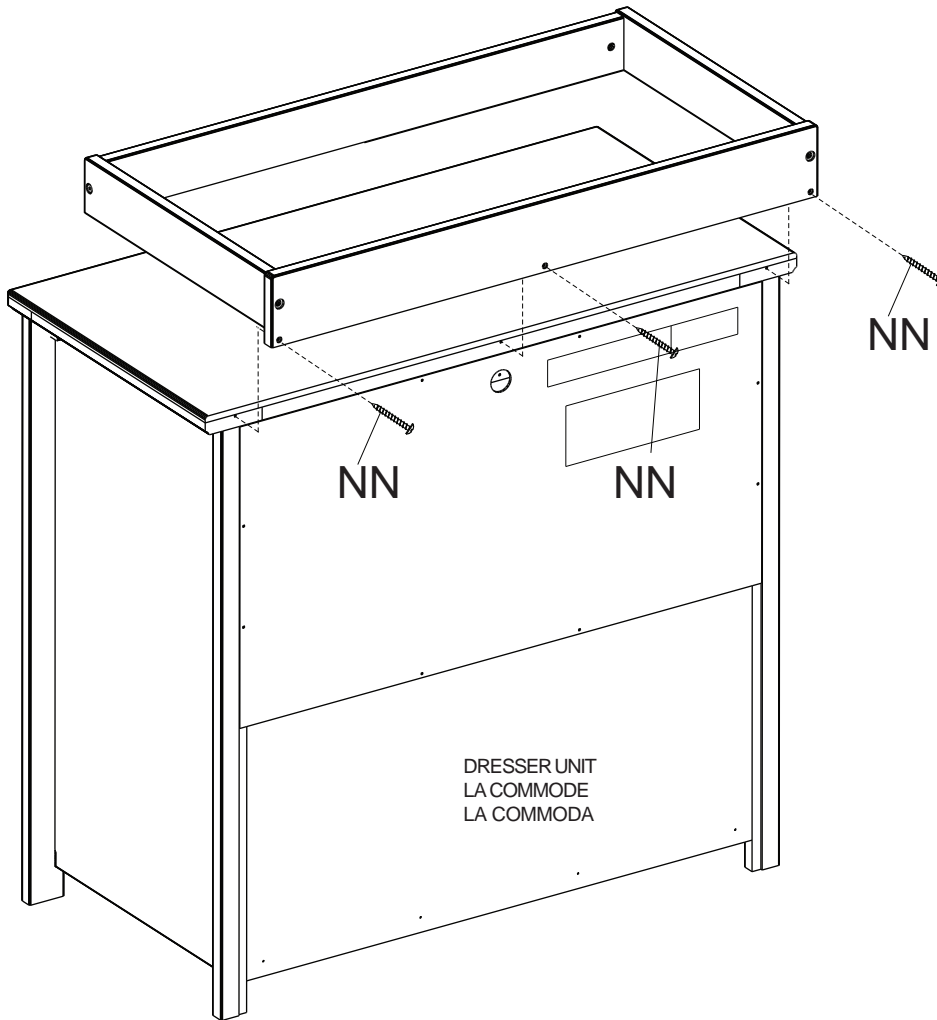

1. Set the Assembled Changing Top on the top of the Dresser as shown.
2. Insert (3) 40mm screws (Part NN) through the back of the Changing Top, into the pre drilled holes the dresser.
3. Tighten with a Phillips Screwdriver.

1. Placer la Table à Langer maintenant assemblée sur ledessusde la commode.
2. Insérer (3) vis 40mm (pièce NN) à partir del' arrière de la table à langer, jusque dans les trous deguidage que l'onvientde percer dans la commode.
3. Serrer au moyen d'un tournevis phillips.

1. Poner el equipó de ensamblaje ensima del cambiador.
2. Inserta (3) tornillos 40 mm (pieza NN) en laparte de atras en los wecos pilót.
3. Apriete con destornillador phillips.



## ⚠️WARNING

**Fall Hazard** Children have suffered serious injuries after falling from changing tables. Falls can happen quickly.

- **STAY** within arm's reach of the child.
- **ALWAYS** secure this unit to the support surface using the screws provided. See instructions.
- Read all instructions before use of the changing top.
- **KEEP THESE INSTRUCTIONS IN A SAFE PLACE FOR FUTURE USE.**
- Inspect the changing top periodically. Do not use the changing top if it is damaged or broken. Contact Delta Children's Products with any questions.
- Tighten all loose screws and bolts before each use.
- The maximum recommended weight of the child is 30lbs for the changing unit.
- Secure the changing unit only to Delta Children's Products item W120030.
- The changing pad used should be 32" x 16" with a maximum thickness of 1".

## ⚠️AVERTISSEMENT

**Danger de chutes.** Des enfants ont souffert de sérieuses blessures après être tombés des tables à langer. Les chutes peuvent arriver rapidement.

- **RESTEZ** à portée de bras de l'enfant.
- Sécurisez **TOUJOURS** cette unité à la surface de support à l'aide des vis fournies. Voir les instructions.
- Lisez toutes les instructions avant d'utiliser la table à langer
- **CONSERVER CES INSTRUCTIONS DANS UN ENDROIT SÛR POUR RÉFÉRENCE ULTÉRIEURE.**
- Inspecter régulièrement la table à langer. Ne pas l'utiliser si elle est endommagée ou brisée. Si vous avez des questions contactez Delta Children's Products.
- Serrer tous les boulons et vis desserrés avant chaque usage.
- La table à langer ne doit pas être utilisée pour un enfant pesant plus de 13,6 kg (30 lb.).
- La table à langer doit être fixé à seulement Delta Children's Products produit W120030.
- Le coussin à langer doit mesurer 32 po x 16 po et avoir une épaisseur maximale de 1 po

## ⚠️ADVERTENCIA

**Peligro de caídas.** Hay niños que han sufrido lesiones serias al caer de cambiadores. Las caídas pueden ocurrir en un instante.

- **MANTENERSE** al alcance de la mano del niño.
- Asegurar **SIEMPRE** esta unidad a la superficie de soporte utilizando los tornillos provistos. Ver las instrucciones.
- Lea todas las instrucciones antes de usar el cambiador.
- **COLOQUE ESTAS INSTRUCCIONES EN UN LUGAR SEGURO PARA SU USO FUTURO.**
- Inspeccione este cambiador periódicamente. No use el cambiador si esta dañado o roto. Póngase en contacto con Delta Children's Products para formular preguntas.
- Apriete los tornillos y pernos flojos antes de cada uso.
- El peso máximo recomendado para los niños que usen el cambiador es 30 libras (13,6 kilos).
- Asegure el cambiador sólo al producto Delta Children's Products W120030.
- La almohadilla usada debe ser 32 x 16 pulgadas con un grosor máximo de 1 pulgada.

**Step 8**  
**Étape 8**  
**Paso 8**

**Tipover Restraint**  
**Dispositif de non-renversement**  
**Protección contra volcamiento**

**▲ WARNING**

Use of tip-over restraints may only reduce, but not eliminate, the risk of tip-over.

Do not attempt to screw into the wallboard only. You must screw into a wood wall stud or other wood structure such as securely attached baseboard. If your wall is not wood stud construction, see your local hardware store or home center for a wall anchor system that will hold a pull force of 50 LBS in your wall type. If you are unsure of how to locate the wood stud, or of what type of wall you have, contact a professional contractor.

**▲ AVERTISSEMENT**

L'utilisation de dispositif anti-renversement peut uniquement réduire les risques de renversement, mais ne les élimine pas totalement.

Ne tentez pas de le visser dans le panneau de revêtement uniquement. Vous devez visser dans un poteau mural en bois ou toute autre structure en bois telle qu'une plinthe solidement fixée. Si votre mur n'est pas construit de montants de bois, voyez votre quincaillerie locale ou centre de rénovation pour une ancre de mur pouvant supporter 50 livres dans votre type de mur. Si vous êtes incertain par rapport à comment localiser le montant ou à quel type de mur vous avez, contactez un entrepreneur professionnel.

**▲ ADVERTENCIA**

El uso de herramientas de contención de vuelcos tan solo puede reducir, pero no eliminar, el riesgo de vuelco.

No intente atornillar a paredes hechas únicamente de paneles. Debe atornillar en un pilar u otra estructura de madera similar, como un zócalo fijado de manera segura. Si su pared no tiene vigas de Madera, visite su ferretería o tienda del ramo más cercana para conseguir un sistema de anclaje que soporte una fuerza de tiraje de hasta 50 LBS (22,7 Kgs) para su tipo de muro. Si no está seguro sobre cómo encontrar la viga de madera o tiene dudas sobre el tipo de muro, contacte a un contratista profesional.

- 1) Choose BOTTOM or TOP attachment.
- 2) Locate the through holes in the back of the dresser.
- 3) Align the hole to be used with the wood wall stud (For Open Bottom Installation, use wood wall stud closest to center)
- 1) Choisissez une fixation SUPÉRIEURE ou INFÉRIEURE.
- 2) Repérez les trous percés au dos de la commode.
- 3) Alignez le trou à utiliser sur le poteau mural en bois (Pour une installation à fond ouvert, utilisez le poteau mural le plus près du milieu)
- 1) Seleccione el aditamento SUPERIOR o INFERIOR.
- 2) Ubique los orificios pasantes en la parte posterior del mueble.
- 3) Alinee el orificio que utilizará con el pilar de la pared (para una instalación con fondo abierto, utilice el pilar de madera más cercano al centro)

- 4) Make a pencil mark on the wall using the wood rail as a guide, pencil mark must be over wood wall stud. Then move the case away from the wall.
- 4) Faites une marque sur le mur à l'aide d'un crayon en vous servant du barre en bois comme guide, la marque au crayon doit être au-dessus du poteau mural en bois. Ensuite, déplacez la caisse afin de l'éloigner du mur.
- 4) Utilizando un lápiz, haga una marca en la pared utilizando el barra de madera como guía; la marca debe estar sobre el pilar de madera. Luego, aleje la carcasa de la pared.

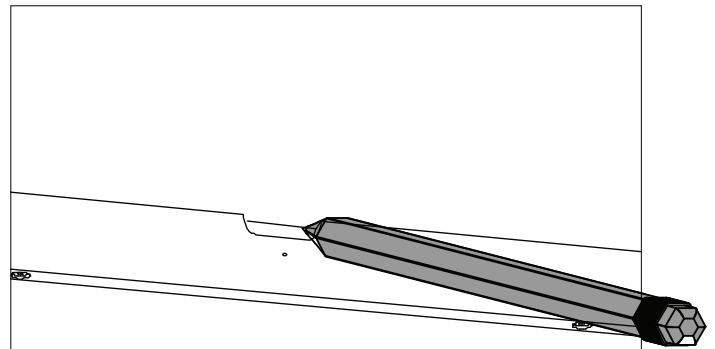

- 5) Drill Ø1/8" hole at Pencil Mark, in wood wall stud
- 5) Percez un trou de 1/8 po de diamètre à l'emplacement de la marque au crayon, dans le poteau mural en bois
- 5) Perfore un orificio de Ø1/8" en la marca del lápiz, sobre el pilar de madera

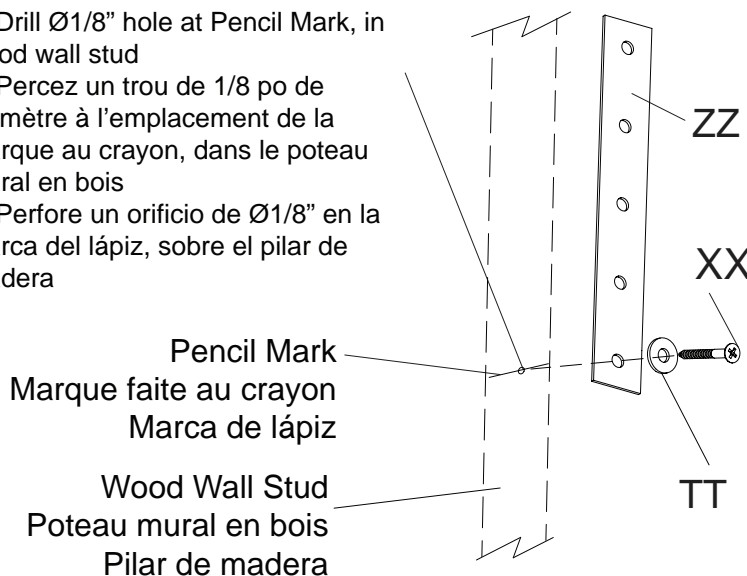

- 6) Attach the Tip-over restraint strap (ZZ) to the wall using (1) Long Screw (XX) and (1) washer (TT) as shown. The screw MUST be installed into a wood wall stud (See WARNINGS for additional information).

6) Fixez la sangle du dispositif de non-renversement (ZZ) au mur à l'aide de (1) vis longue (XX) et de (1) rondelle (TT) tel qu'illustré. La vis DOIT être serrée dans un poteau mural en bois (Pour de plus amples informations, veuillez vous référer aux AVERTISSEMENTS).

6) Fije la correa de retención contra volcamiento (ZZ) a la pared utilizando (1) tornillo largo (XX) y (1) arandela (TT), como se indica. El tornillo DEBE instalarse en un pilar de madera (para obtener más información consulte las ADVERTENCIAS).

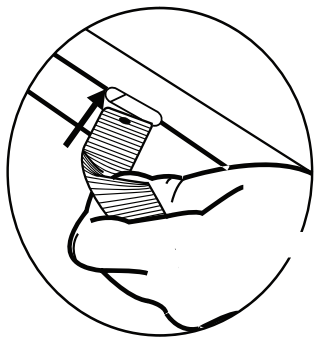

NOTE: Be sure to attach any accessory items to case before completing this step.  
 7) Feed the Tipover Restraint through the hole as you place the dresser in it's final position.  
 REMARQUE : Veuillez à fixer tous accessoires sur la caisse avant de l'exécution de cette étape.  
 7) Faites entrer le dispositif de non-renversement à travers le trou lorsque vous placez la commode dans s position finale.  
 NOTA: Asegúrese de fijar todos los accesorios a la carcasa antes de completar este paso.  
 7) Pase el elemento de retención a través del orificio, a medida que posiciona el mueble en su posición final.

8) Pull the Tip-over restraint through the hole and fasten it securely to the case using (1) 15mm screw (YY) and (1) washer (TT).  
 8) Tirez le dispositif de non-renversement à travers le trou, puis fixez-le solidement sur la caisse à l'aide de (1) vis de 15 mm (YY) et de (1) rondelle (TT).  
 8) Pase el elemento de retención a través del orificio y fíjelo con seguridad a la carcasa utilizando (1) tornillo de 15 mm (YY) y (1) arandela (TT).

Attach to Top  
 Fixez-le à la partie supérieure  
 Fijar a la parte superior

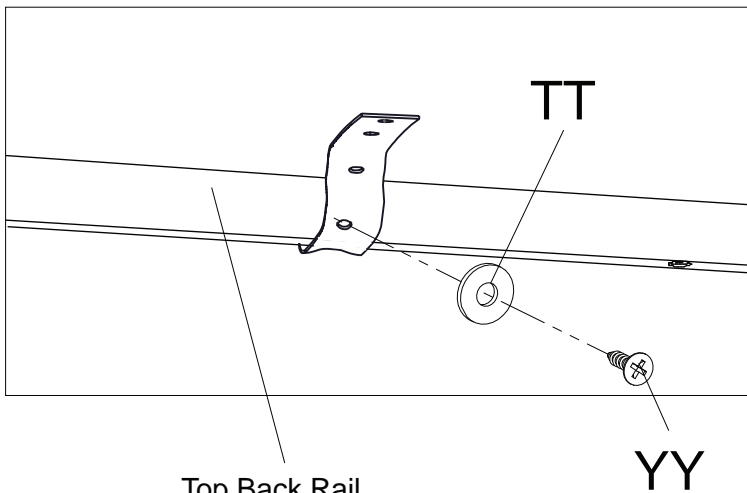

Top Back Rail  
 Barre Arrière Supérieur  
 Barra Trasero Superior

Attach to Bottom  
 Fixez-le à la partir inférieure  
 Fijar al fondo

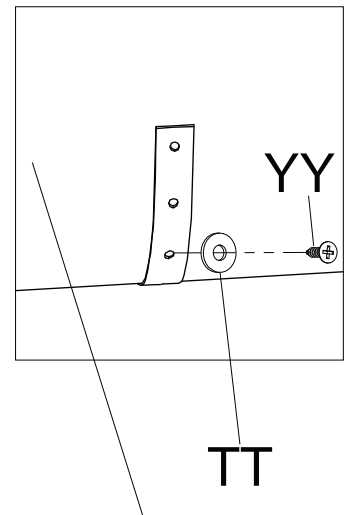

Bottom Back Rail  
 Barre Arrière Inférieur  
 Barra Trasero Inferior

9) Pull case AWAY from wall until Restraint is SNUG.  
 9) Tirez la caisse afin de L'ÉLOIGNER du mur jusqu'à ce que le dispositif de non-renversement soit BIEN AJUSTÉ  
 9) Jale la carcasa ALEJÁNDOLA de la pared hasta que la retención esté TENSA.

10) Ensure restraint is not loose.  
 10) Assurez-vous que le dispositif de non-renversement n'est pas desserré.  
 10) Asegúrese de que la retención no esté suelta.

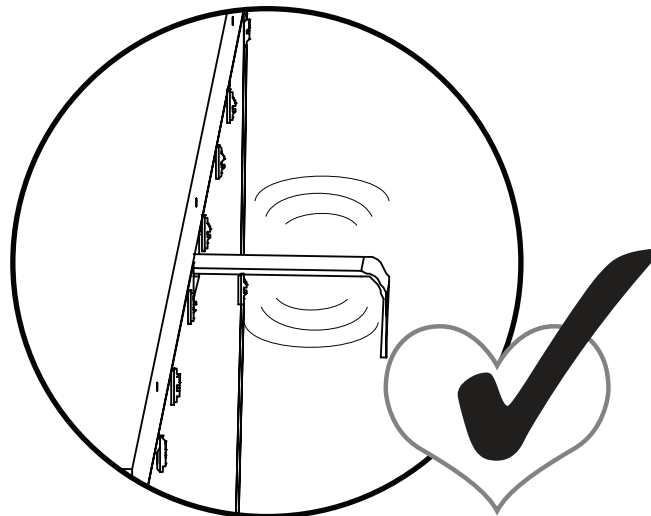
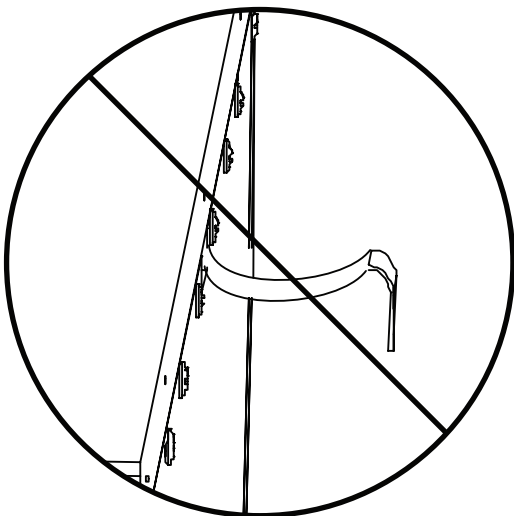



Step 9  
Étape 9  
Paso 9

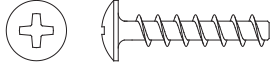

LL. 20mm Screw x12  
Vis 20mm  
Tornillo 20mm

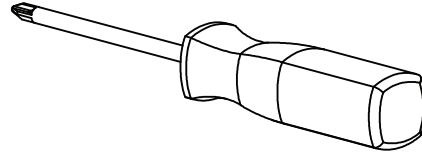

Phillips Screwdriver – Not included  
Tournevis Phillips - non inclus  
Destornillidor Phillips – no incluido

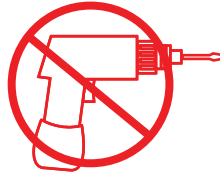

**CAUTION:** Do Not use a power screwdriver they can cause screws to break or strip.  
**ATTENTION:** Ne Pas utiliser un tournevis électrique car les vis peuvent casser ou perdre leurs filets.  
**ATENCIÓN:** No use un destornillador eléctrico ya que puede causar que los tornillos se rompan o rueden.

Slide Drawer Bottom (Part S) into the grooves. Attach (2) Drawer Sides (Part U) to the Drawer Front (Part N) with (4) 20mm Screws (Part LL). Note: Grooves in Bottom must align. Tighten With Phillips Screwdriver. Repeat this step until 3 drawers are complete.

Glisser le fond du tiroir (Pièce S) dans les rainures. Fixer (2) Barre de tiroir (Pièce U) à l'avant du tiroir (Pièce N) à l'aide de (4) vis 20mm (Pièce LL). Remarque: Les rainures inférieures doivent être alignées. Serrer avec un tournevis Phillips. Répéter cette étape jusqu'à ce que les 3 tiroirs soient montés.

Deslice la Fondo de la gaveta (Pieza S) hacia las ranuras. Fije (2) Barra de la gaveta (Pieza U) a la parte frontal de la gaveta (Pieza N) utilizando (4) tornillos 20mm (Pieza LL). Nota: Las ranuras al inferior deben alinearse. Apriete utilizando un destornillador Phillips. Repitaestepaso hasta haber completadolos 3 gavetas .

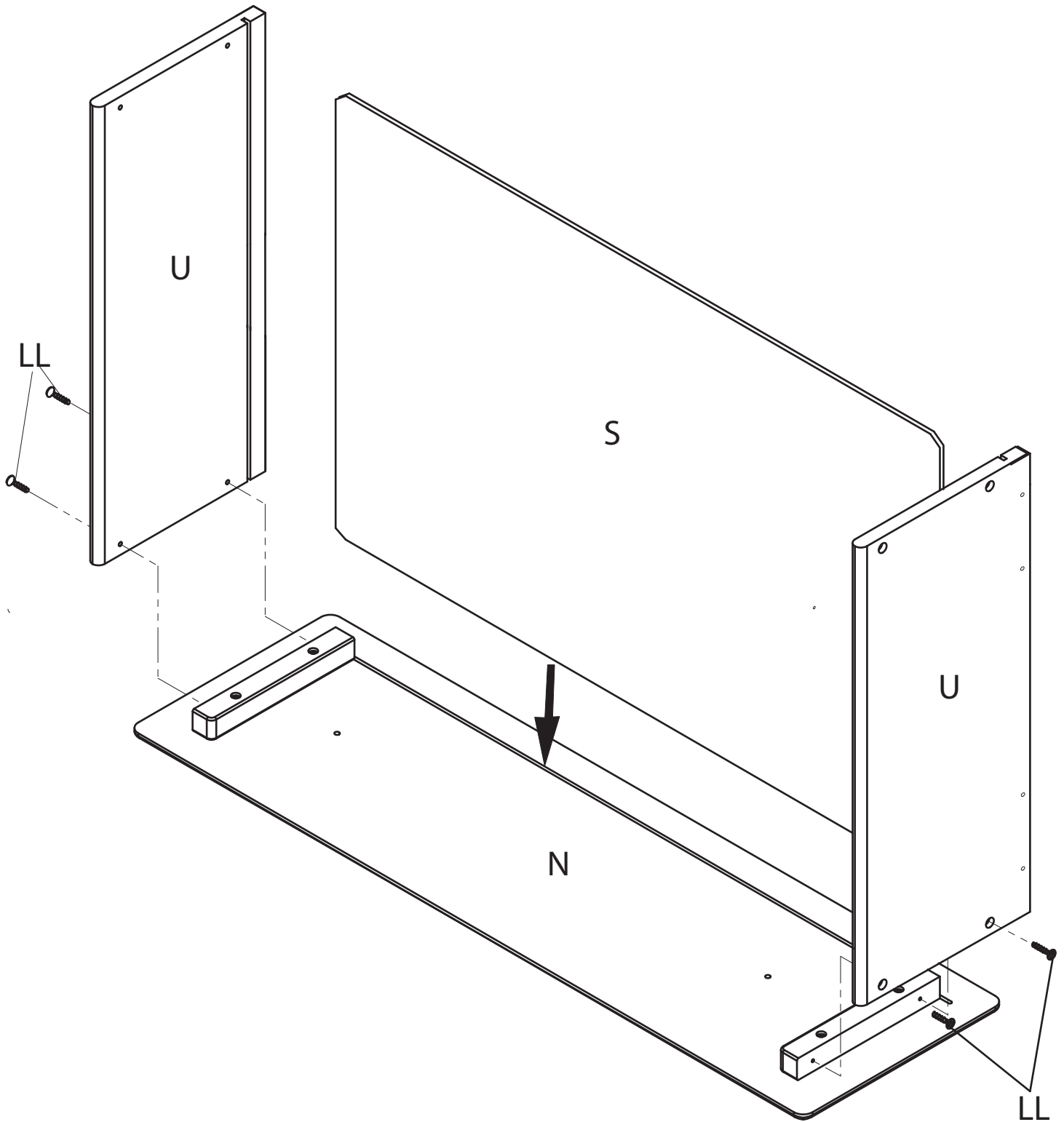



Step 10  
Étape 10  
Paso 10

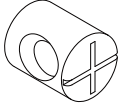

KK. Plastic Barrel Nut x12  
Écrou à portée cylindrique  
en plastique  
Tuerca cilíndrica plástica

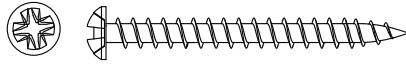

NN. 40mm SCREW x12  
Vis 40mm  
Tornillo 40mm

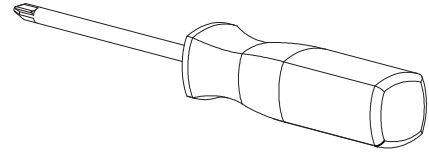

Phillips Screwdriver – Not included  
Tournevis Phillips - non inclus  
Destornillidor Phillips – no incluido

**CAUTION:** Do Not use a power screwdriver they can cause screws to break or strip.

**ATTENTION:** Ne Pas utiliser un tournevis électrique car les vis peuvent casser ou perdre leurs filets.

**ATENCIÓN:** No use un destornillador eléctrico ya que puede causar que los tornillos se rompan o rueden.

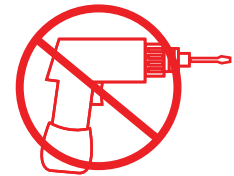

Install the Drawer Back (Part P) using (4) 40mm Screws (Part NN) and (4) Plastic Barrel Nuts (Part KK). Note: Grooves In Bottom Must Align. Tighten With Phillips Screwdriver. Repeat this step until 3 drawers are complete.

Installer le arrière du tiroir (Pièce P) à l'aide de (4) vis 40mm (Pièce NN) et de (4) Écrous à portée cylindriques en plastique (Pièce KK). Remarque: Les rainures inférieures doivent être alignées. Serrer avec un tournevis Phillips. Répéter cette étape jusqu'à ce que les 3 tiroirs soient montés.

Instale el Trasera de la gaveta (Pieza P) utilizando (4) tornillos de 40 mm (Pieza NN) y (4) tuercas cilíndricas plásticas (Pieza KK). Nota: Las ranuras al inferior deben alinearse. Apriete utilizando un destornillador Phillips. Repita este paso hasta haber completado las 3 gavetas.



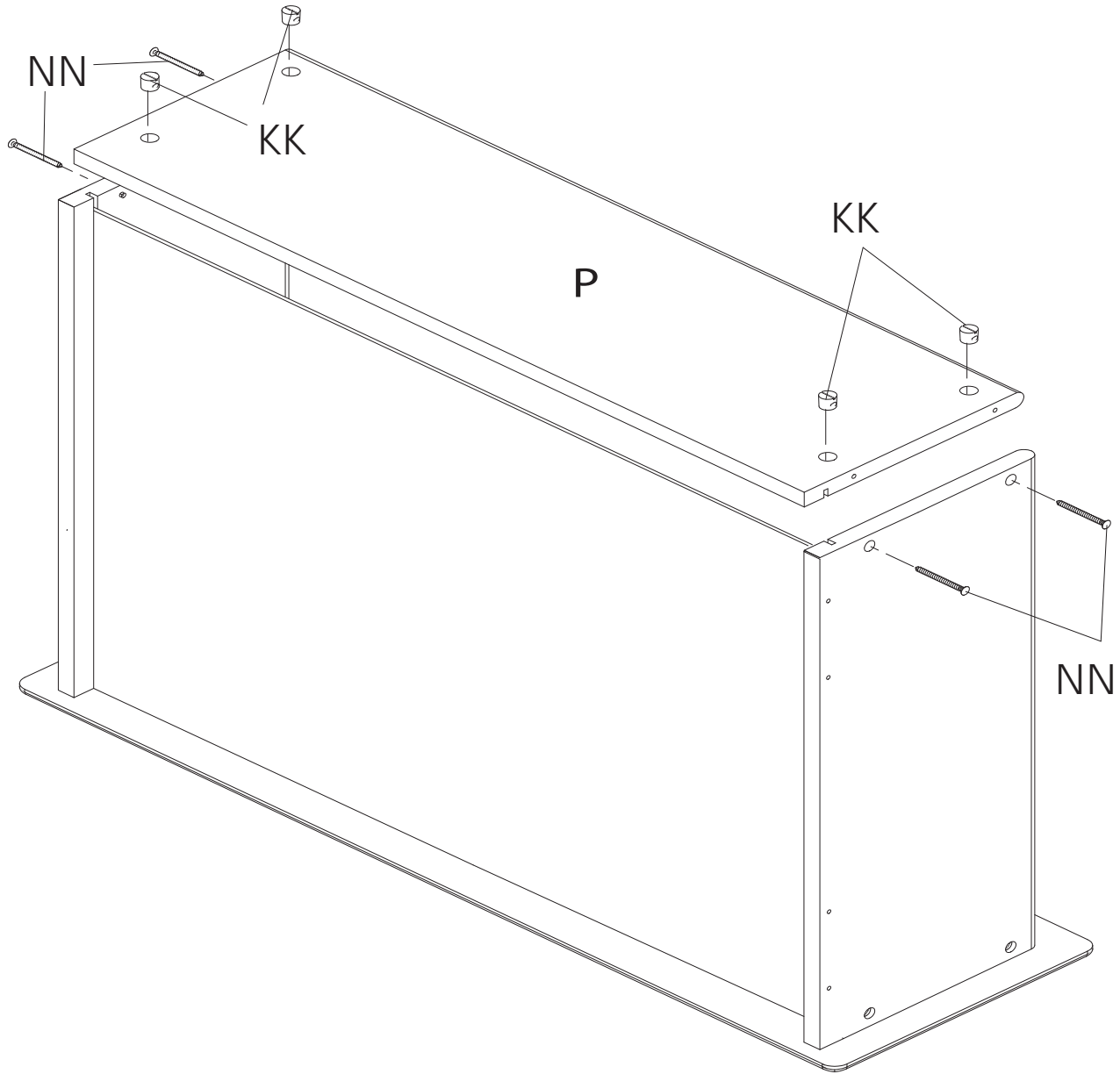

x3



Step 11  
Étape 11  
Paso 11

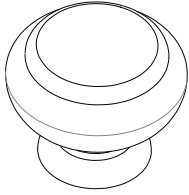

PP1. Knob x6  
Bouton  
Perilla

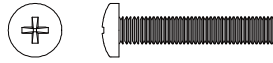

PP2. Knob Screw x6  
Vis de Bouton  
Tornillo para Perilla

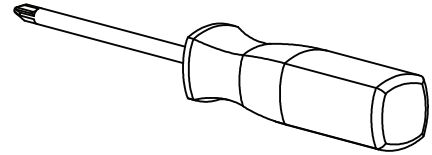

Phillips Screwdriver – Not included  
Tournevis Phillips - non inclus  
Destornillador Phillips – no incluido

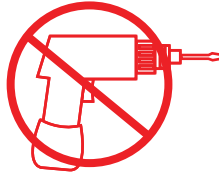

**CAUTION:** Do Not use a power screwdriver they can cause screws to break or strip.  
**ATTENTION:** Ne Pas utiliser un tournevis électrique car les vis peuvent casser ou perdre leurs filets.  
**ATENCIÓN:** No use un destornillador eléctrico ya que puede causar que los tornillos se rompan o rueden.

Attach (2) Knobs (Part PP1) to Drawer Assembly using (2) Knob Screws (Part PP2). Repeat this step until 3 drawers are complete.

Fixer le (2) boutons (Pièce PP1) au montage assemblé du tiroir à l'aide d'(2) vis de Bouton (Pièce PP2). Répéter cette étape jusqu'à ce que les 3 tiroirs soient montés.

Fije la(2) perillas (Pieza PP1) al ensamblaje de la gaveta utilizando (2) tornillos para Perilla (Pieza PP2). Repita este paso hasta haber completado las 3 gavetas.

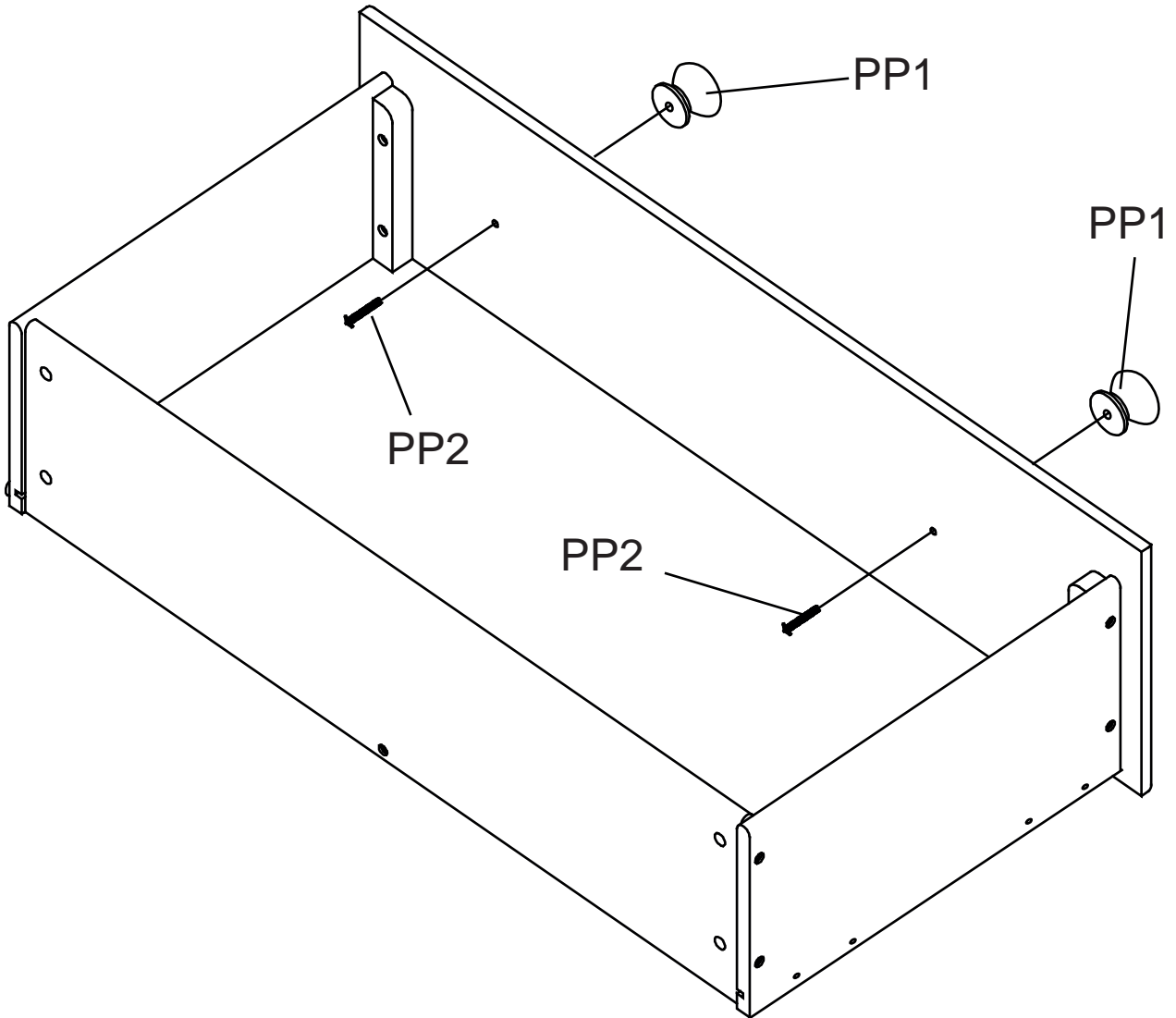

x3



Step 12  
Étape 12  
Paso 12

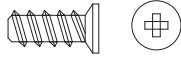

AA.12mm Screw x12  
Vis 12mm  
Tornillo 12mm

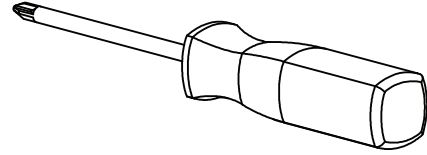

Phillips Screwdriver – Not included  
Tournevis Phillips - non inclus  
Destornillador Phillips – no incluido

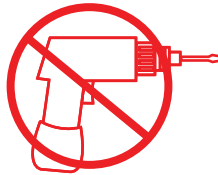

**CAUTION:** Do Not use a power screwdriver they can cause screws to break or strip.  
**ATTENTION:** Ne Pas utiliser un tournevis électrique car les vis peuvent casser ou perdre leurs filets.  
**ATENCIÓN:** No use un destornillador eléctrico ya que puede causar que los tornillos se rompan o rueden.

Attach Left Drawer Guide (Part G) and Right Drawer Guide (Part H) to Drawer Assembly using (4) 12mm Screws (Part AA) in the pre-drilled holes. Tighten with a Phillips Screw Driver. Repeat this step until 3 drawers are complete.

Fixez la glissière du tiroir gauche (Pièce G) et Glissière de tiroir droite (Pièce H) à l'aide de (4) vis de 12 mm (Pièce AA) en les trous prépercés. Serrez à l'aide d'un tournevis cruciforme. Répéter jusqu'à ce que les (3) tiroirs soient montés.

Fije la guía de gaveta izquierda (Pieza G) y la Guía de gaveta derecha (Pieza H) con (4) tornillos de 12 mm (Pieza AA) en los agujeros pre taladrados. Apriete con un destornillador Philips. Repita hasta completar las (3) gavetas.



x3

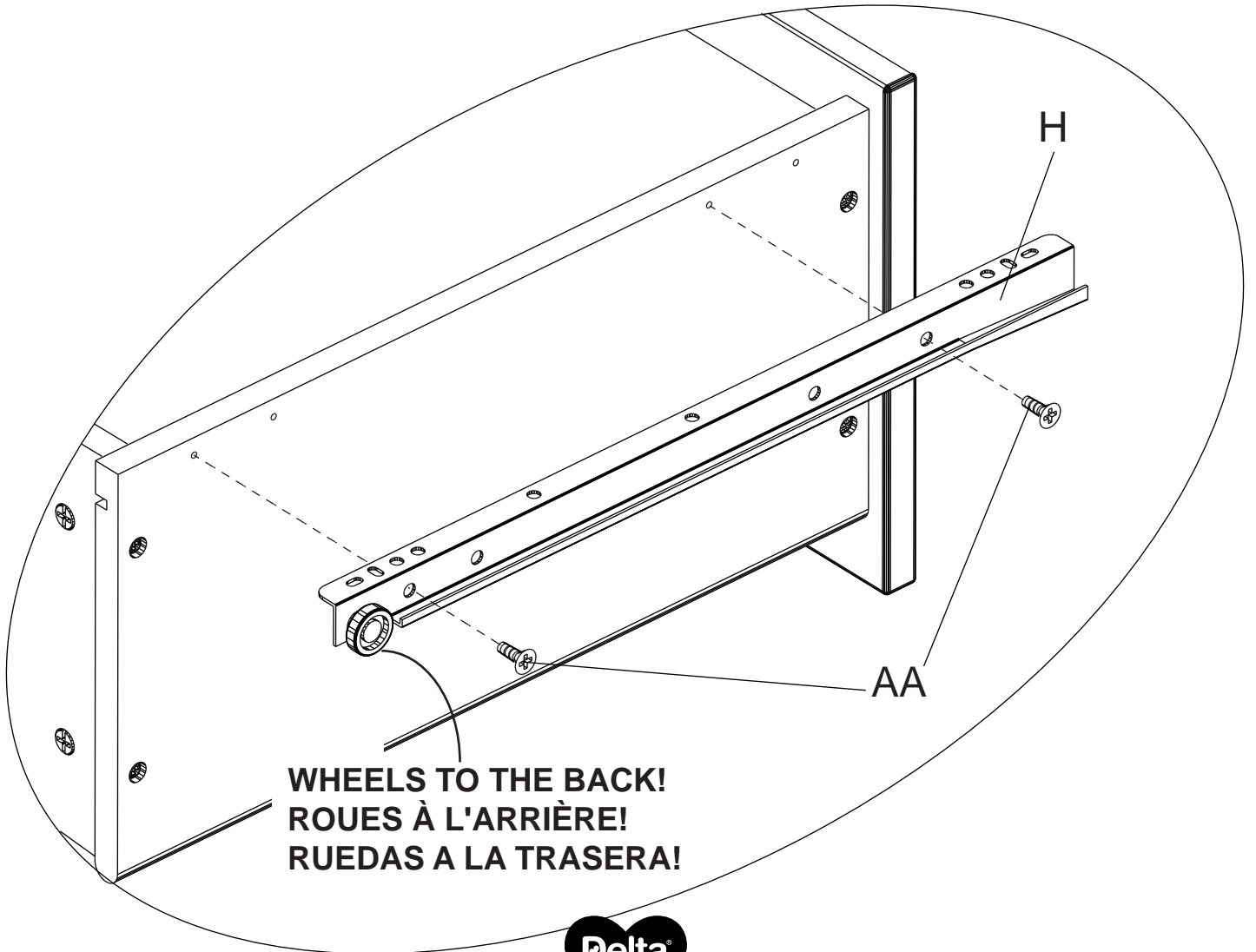
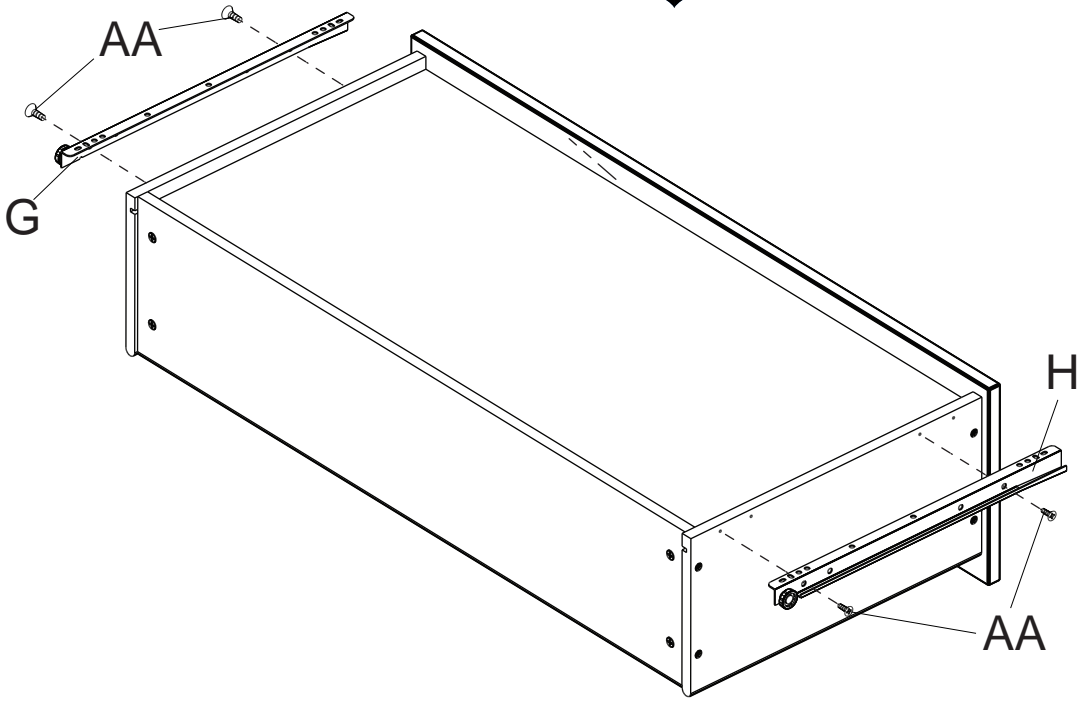

**WHEELS TO THE BACK!**  
**ROUES À L'ARRIÈRE!**  
**RUEDAS A LA TRASERA!**





Step 13  
Étape 13  
Paso 13

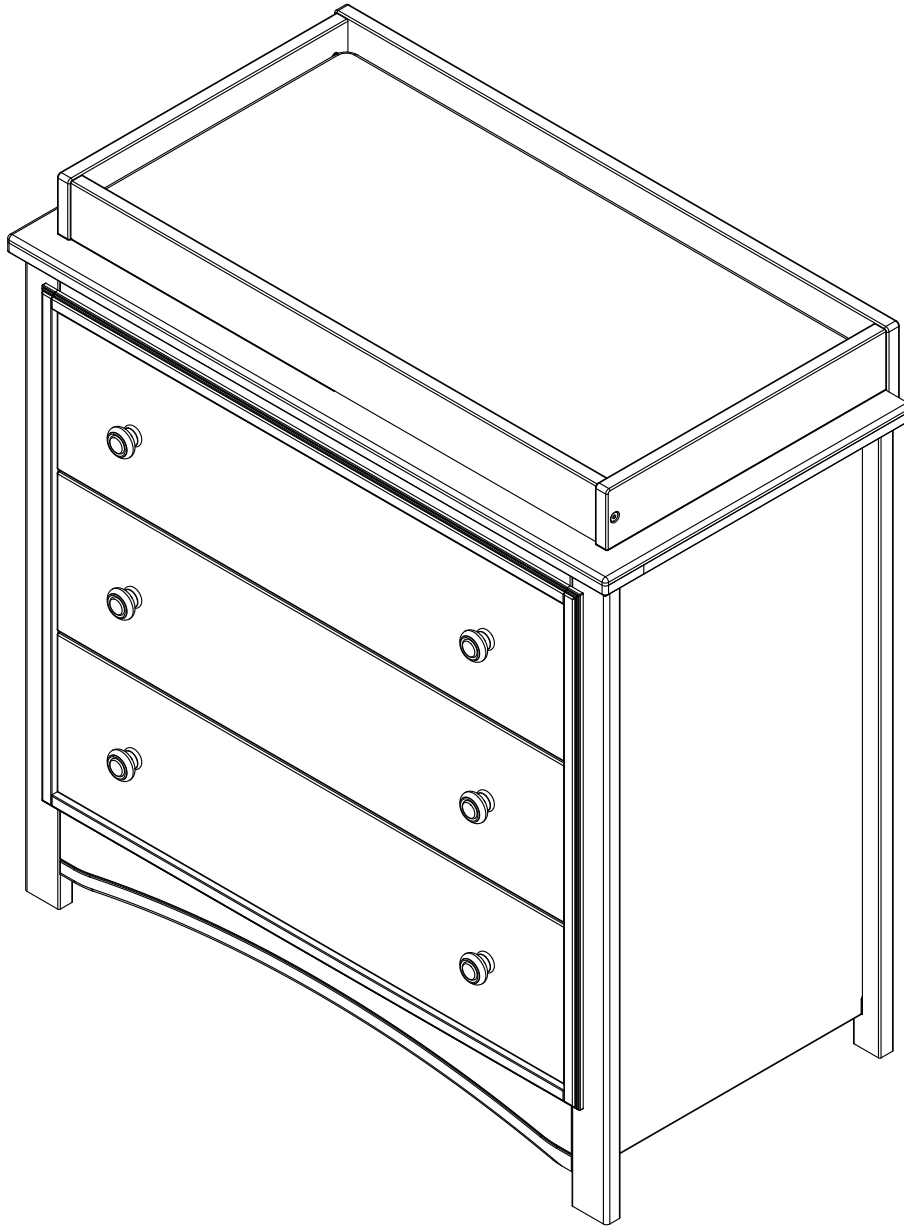

Install the drawers in the case body. Changing the locations may improve fit or performance.

Installez les tiroirs dans le corps du boîtier. Modifiez l'emplacement pour un meilleur ajustement ou de meilleures performances.

Instale las gavetas en el cuerpo del mueble. Cambiar las ubicaciones podría mejorar el funcionamiento.





## Consumer Experience Center

[www.DeltaChildren.com](http://www.DeltaChildren.com)

Delta Children's Products Corp

114 West 26th Street

New York, NY 10001

(646) 435-8727

[wcs@DeltaChildren.com](mailto:wcs@DeltaChildren.com)

**Limited Warranty:** This Delta product is warranted to be free from defects for a period of 90 days from the date of purchase under normal use. This warranty extends only to the original retail purchaser and is valid only when supplied with proof of purchase, or if received as a gift, when the registration is on file with Delta. This limited warranty **does not cover** the following:

- Products purchased as floor models or samples.
- Items purchased on an “as-is” basis, as a second hand product, or as a resale product.
- Items purchased at a Final sale, a “Going out of Business” sale or a Liquidation sale.

**Garantie Limitée:** Ce produit Delta est garanti libre de défauts pour une période de 90 jours à partir de son achat et dans des conditions normales d'utilisation. Cette garantie se donne uniquement à l'acheteur d'origine et elle est valable seulement sur présentation d'une preuve d'achat, ou si le produit a été reçu en tant que cadeau alors il doit avoir été enregistré chez Delta. Cette garantie limitée du fabricant **ne couvre pas** les cas suivants :

- Produits achetés comme modèles d'exposition ou échantillons.
- Articles achetés comme « en l'état », produits d'occasion ou revente des produits.
- Articles achetés en « vente finale », ventes dans « magasins en faillite » ou ventes par liquidation.

**Garantía Limitada:** Este producto Delta está garantizado de estar libre de defectos por un período de 90 días a partir de su adquisición, bajo uso normal. Esta garantía se otorga únicamente al comprador original y es válida solamente cuando se proporciona una prueba de compra, o si el producto fue recibido como un regalo, debe haber sido registrado con Delta. Esta garantía limitada del fabricante **no cubre** lo siguiente:

- Productos comprados como exhibiciones de la tienda o muestras.
- Artículos comprados como “tal como está”, productos de segunda mano o reventa de los productos.
- Artículos comprados como “venta final”, “ventas de tiendas que están quebrando” o ventas por liquidación.

To register your product for important safety alerts and updates to your product please visit **[www.deltachildren.com](http://www.deltachildren.com)**

Pour enregistrer votre produit pour avoir les alertes de sécurité et les mises à jour de votre produit veuillez visiter **[www.DeltaChildren.com](http://www.DeltaChildren.com)**

Para registrar su producto para alertas importantes de seguridad y estar al tanto sobre novedades de su producto por favor visite **[www.DeltaChildren.com](http://www.DeltaChildren.com)** y seleccione Product Registration.

To report a problem, please log on to **[www.deltachildren.com](http://www.deltachildren.com)** and click the Consumer Care Tab, or contact us by phone at (646) 435-8727

Pour signaler un problème, veuillez vous connecter à **[www.DeltaChildren.com](http://www.DeltaChildren.com)** et cliquez sur la touche Consumer Care, ou contactez nous par téléphone au (646) 435-8727

Para reportar cualquier problema, por favor entre a **[www.DeltaChildren.com](http://www.DeltaChildren.com)** y de clicen Servicio al cliente o contáctenos por teléfono al (646) 435-8727

**Date of Purchase:** \_\_\_\_\_ (you should also keep your receipt)

**Date d'Achat:** \_\_\_\_\_ (vous devriez aussi garder votre facture d'achat)

**Fecha de Compra:** \_\_\_\_\_ (debe además mantener su recibo)



# SAFETY LEADERS

Visit [Deltachildren.Com/Pages/Leaders-In-Safety](https://Deltachildren.Com/Pages/Leaders-In-Safety) for more information

## SAFE MATERIALS

Safe products start with safe materials. We test all of our products to create the safest and healthiest environment for your baby.



## PRODUCTS YOU CAN TRUST

We have 8 cutting edge safety labs around the world where we test our products above and beyond the industry standards. All of our dressers are engineered to meet or exceed ASTM Furniture Safety Standards.



## WE GO ABOVE & BEYOND

To protect your children, Delta Children dressers are tested to meet the requirements of the industry tip over test set forth by ASTM. For additional security, we strongly recommend that all dressers in your home be anchored; all Delta Children dressers include a wall anchor.







# LEADERS EN MATIÈRE DE SÉCURITÉ

Visitez [Deltachildren.Com/Pages/Leaders-In-Safety](https://Deltachildren.Com/Pages/Leaders-In-Safety) pour plus d'informations

## MATÉRIAUX SURS

Les produits surs sont faits à partir de matériaux surs. Nous testons tous nos produits pour créer l'environnement le plus sûr et plus sain pour votre bébé.



## DES PRODUITS FIABLES

Nous possédons 8 laboratoires de pointe en matière de sécurité où nous testons nos produits au delà des standards industriels. Toutes nos commodes sont conçues pour être aux normes selon les standards de sureté des meubles ASTM et même les dépasser.



## NOUS ALLONS AU-DELÀ

Pour protéger vos enfants, les commodes de Delta Children sont testées pour satisfaire les exigences du test industriel de basculement indiqué par ASTM. Pour une sécurité additionnelle, nous recommandons fortement l'ancrage de toutes les commodes dans votre maison; toutes les commodes de Delta Children incluent une fixation pour le mur.





# LÍDERES EN LA SEGURIDAD

Visite [Deltachildren.Com/Pages/Leaders-In-Safety](http://Deltachildren.Com/Pages/Leaders-In-Safety) para más información

## MATERIALES SEGUROS

Los productos seguros se hacen con materiales seguros. Ponemos a prueba todos nuestros productos para crear el ambiente más seguro y saludable para su bebé.



## PRODUCTOS CONFIABLES

Tenemos 8 laboratorios de seguridad de alta tecnología donde probamos nuestros productos mas allá de los estándares de la industria. Todos nuestros tocadores están diseñados para cumplir o exceder los estándares de seguridad ASTM de muebles.



## ESTAMOS POR ENCIMA Y MÁS ALLÁ

Para proteger a sus niños, los tocadores de Delta Children son sometidos a pruebas para que cumplan los requisitos ASTM establecidos de la industria en cuanto a volcamientos se refiere.

Para seguridad adicional, recomendamos enfáticamente que todos los tocadores de su casa estén fijos: todos los tocadores de Delta Children incluyen un anclaje de pared.





# POURQUOI CHOISIR POR QUÉ ELEGIR A DELTA CHILDREN?

Visitez [Deltachildren.Com/Pages/Our-Story](http://Deltachildren.Com/Pages/Our-Story) pour plus d'information

Visita [Deltachildren.Com/Pages/Our-Story](http://Deltachildren.Com/Pages/Our-Story) para más información

<p><b>DELTA EN TÊTE</b> Un enfant sur deux aux U.S.A. dort dans nos produits</p> <p><b>DELTA LIDERA</b> 1 de cada 2 niños en los EE.UU duerme en nuestros productos</p>	<p><b>DELTA DONNE</b> 10% de nos revenus sont dédiés à l'amélioration de la vie des enfants</p> <p><b>DELTA DONA</b> 10% de nuestros ingresos está destinado a mejorar la vida de los niños</p>	<p><b>DELTA PREND SOIN</b> Nous testons la conformité au-delà des standards de sécurité de l'industrie</p> <p><b>A DELTA LE IMPORTA</b> Hacemos pruebas por encima de los estándares de seguridad de la industria</p>	<p><b>DELTA EST DÉVOUÉ</b> familiale a été présente pour votre famille depuis 1968</p> <p><b>DELTA ESTÁ DEDICADA</b> Nuestra empresa familiar ha estado siempre presente para su familia desde 1968</p>	<p><b>DELTA GRANDIT AVEC VOUS</b> Nous avons des produits pour chaque âge et chaque étape</p> <p><b>DELTA CRECE CON USTEDES</b> Tenemos productos para cada edad y etapa</p>	<p><b>Plus De 50 Ans De Sécurité, Design &amp; Innovation</b></p> <p><b>Más De 50 Años De Seguridad, Estilo E Innovación</b></p>
---	---	---	---	--	--

Bienvenue dans la **FAMILLE DELTA**  
Voici Notre Cadeau Pour Vous  
Bienvenido a la **FAMILIA DELTA**  
Aquí Está Nuestro Regalo Para Usted

**10% OFF**

Votre Prochain Achat Chez  
Su Próxima Compra En  
[DeltaChildren.com](http://DeltaChildren.com)

**UTILISEZ LE CODE:  
UTILICE EL CÓDIGO:  
DELTA10**

\*Des exclusions s'appliquent  
\*Sujet à changement      \*Exclusions Apply  
\*Subject to Change

## DES PRODUITS POUR CHAQUE ÂGE ET CHAQUE ÉTAPE PRODUCTOS PARA CADA EDAD Y ETAPA



NOTRE FAMILLE DE MARQUES SUPÉRIEURES / NUESTRA FAMILIA DE LAS MEJORES MARCAS



PLUS DE 50 ANS DE SÉCURITÉ, DESIGN & INNOVATION / MAS DE 50 ANOS DE SEGURIDAD, ESTILO E INNOVACIÓN





# WHY CHOOSE DELTA CHILDREN?

Visit [Deltachildren.Com/Pages/Our-Story](http://Deltachildren.Com/Pages/Our-Story) for more information

<p><b>DELTA LEADS</b> 1 Out Of 2 Children In The U.S. Sleep In Our Products</p>	<p><b>DELTA GIVES</b> 10% Of Our Profits Go Toward Improving The Lives Of Children</p>	<p><b>DELTA CARES</b> We Test Above &amp; Beyond Industry Safety Standards</p>	<p><b>DELTA IS DEDICATED</b> Our Family-Run Company Has Been There For Your Family Since 1968</p>	<p><b>DELTA GROWS WITH YOU</b> We Have Products For Every Age And Stage</p>	<p>Over 50 Years Of Safety, Style &amp; Innovation</p>
---	--	--	---	---	--

Welcome to the  
**DELTA FAMILY**  
Here's a Gift From Us To You

**10% OFF**

Your Next Purchase From  
[DeltaChildren.com](http://DeltaChildren.com)

USE CODE:  
**DELTA10**

\*Exclusions Apply  
\*Subject to Change

## PRODUCTS FOR EVERY AGE AND STAGE

 CRIBS LITS POUR BÉBÉ CUNAS	 STROLLERS ÉQUIPEMENT POUR BÉBÉ COSAS PARA BEBÉ	 GLIDERS CHAISE SILLA	 BASSINETS COUFFINS MOISÉS	 MATTRESSES MATELAS COLCHÓN	
 BABY GEAR POUSSETTES CARRIOLAS	 TODDLER BEDS LITS POUR ENFANT CAMA PARA NIÑO	 PLAYROOM FURNITURE SALLE DE JEUX CUARTO DE JUGAR	 TWIN BEDS LITS UNE PLACE CAMA SENCILLA	 BINS & ORGANIZERS PANIERES CONTENEDORES	 DRESSERS COMMODOES TOCADORES

## OUR FAMILY OF TOP BRANDS



OVER 50 YEARS OF SAFETY, STYLE, AND INNOVATION

