

OLYMPIA

Side x Side Stroller



INSTRUCTION MANUAL

LF11602

ASSEMBLY INSTRUCTIONS

Styles and colors may vary



Read all instructions BEFORE assembly and USE of product
KEEP INSTRUCTIONS FOR FUTURE USE.

Customer Experience Center
email: gcs@DeltaChildren.com



www.DeltaChildren.com

DCP-IM-20200917

Consumer Information



WARNING

Prevent serious injury from falls or sliding out:

- ALWAYS use the restraint system.
- Only children who have developed enough upper body control to sit without leaning forward can use the front seat in the upright position.
- NEVER leave child unattended.
- DO NOT use the storage bag to carry children.

To prevent product from tipping over:

- DO NOT exceed the maximum storage weight limit of 3 lbs (1.36 kg) in the storage bag or canopy pouch.
- DO NOT exceed the maximum storage weight limit of 3 lbs (1.36 kg) in the cup holder.
- DO NOT place additional items on this product, except as recommended in the instructions.

To prevent injury:

- Make sure all body parts are clear of the stroller when folding and unfolding.
- DO NOT place hot liquids in the cup holder. Hot liquids can burn your child.

- Please read these instructions before assembly and use of this product.
- Adult assembly is required.
- Use only for a children who weigh less than 35 lbs (15.88 kg) in each seat.
- Maximum weight limit for the storage bag and canopy pouch is 3 lbs (1.36 kg).
- Maximum weight limit for the cup holder is 3 lbs (1.36 kg).
- Product features and decorations may vary from the photo.

Care

- The plastic parts may be wiped clean using a mild cleaning solution and damp cloth. Hand wash fabric with damp cloth and air dry. Do not use bleach.
- To keep your stroller wheels from squeaking, use a silicone or graphite based lubricant.



Before returning this product to the store! Let's see if we can assist you!

- **Not sure how to assemble our product?**

Visit our site for easy to follow instructions along with some Tricks and Tips assembly videos <https://www.deltachildren.com/pages/instructions>

- **If you are missing a piece or have a damaged part**

Please contact our Consumer Experience Center for assistance at gcs@DeltaChildren.com. To better assist you please have your Style# or Model# and Lot# available. This can be found on a white rectangular sticker on your product, on the registration card, and on the product's box.

- **In the event we do not have a replacement part available**

You may need to return your product to the retailer for an exchange or refund.

- **Warranty**

In order to protect your investment, don't forget to register your product. You may also wish to consider purchasing our extended warranty.

Visit <https://www.deltachildren.com/pages/extended-warranty> for more details.

- **Please note:**

"All Final", "As Is" or Third Party/Liquidator sales are not covered under our Limited Manufacturer Warranty.

DELTA ♥ CHILDREN

LIMITED MANUFACTURER WARRANTY

This Delta product is warranted to be free from defects for a period of 90 days from the date of purchase under normal use. This warranty extends only to the original retail purchaser and is valid only when supplied with proof of purchase, or if received as a gift, when the registration is on file with Delta. This limited manufacturer warranty does not cover the following:

- Products purchased as floor models or samples.
- Items purchased on an “as-is” basis, as a second hand product, or as a resale product.
- Items purchased at a Final sale, a “Going out of Business” sale, or a Liquidation sale.

TO REGISTER YOUR PRODUCT for important safety alerts and updates to your product please visit www.deltachildren.com

TO REPORT A PROBLEM, please log on to www.deltachildren.com and click the Consumer Care Tab, or contact us by email at gcs@DeltaChildren.com

Date of Purchase: _____ (you should also keep your receipt)

EXTENDED WARRANTY

DON'T MISS YOUR CHANCE TO BE COVERED FOR ALL OF LIFE'S MISHAPS!

With Delta's Extended Warranty, you're covered for mechanical failure from normal use or if your item stops working due to normal wear and tear, plus all those unexpected surprises.

2 YEARS OF PROTECTION

For Additional Information:

Simply visit our Website, register your product, and add the Extended Warranty

<https://www.deltachildren.com/pages/product-registration>

Extended Warranty only available in the following States: Arkansas, Colorado, Delaware, District of Columbia, Georgia, Idaho, Illinois, Indiana, Iowa, Kansas, Kentucky, Louisiana, Maryland, Michigan, Mississippi, Missouri, Nebraska, Nevada, New Hampshire, New York, North Carolina, North Dakota, Pennsylvania, Rhode Island, South Dakota, Tennessee, Utah, West Virginia

Parts

IMPORTANT! Please remove all parts from the package and identify them before assembly.

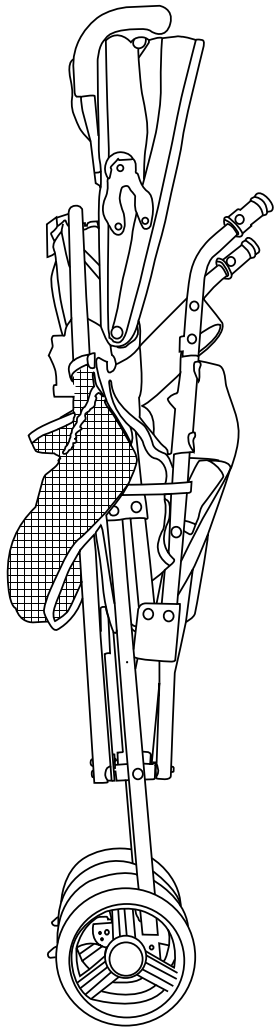

Stroller

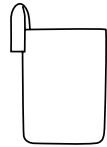

Cup Holder

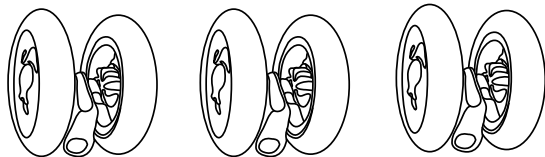

3 Front Wheel Assemblies

Assembly

IMPORTANT! Before assembly or each use, inspect this product for damaged hardware, loose joints, missing parts or sharp edges. DO NOT use if any parts are missing or broken. Contact manufacturer for replacement parts and instructions if needed. Never substitute parts.

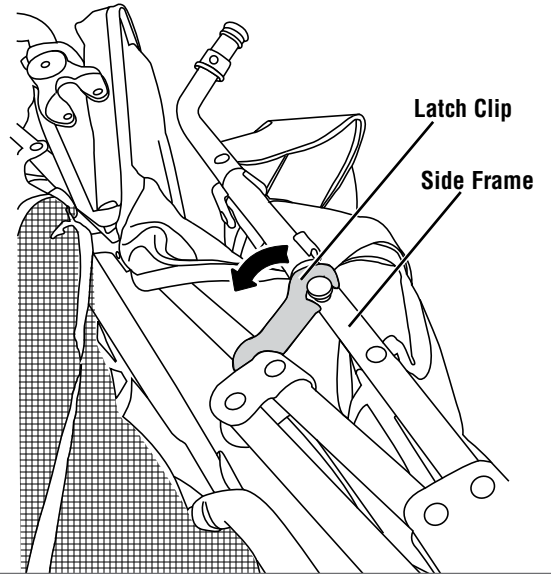

- Locate the latch clip on the side frame of the stroller.
- Pull to release the latch clip.

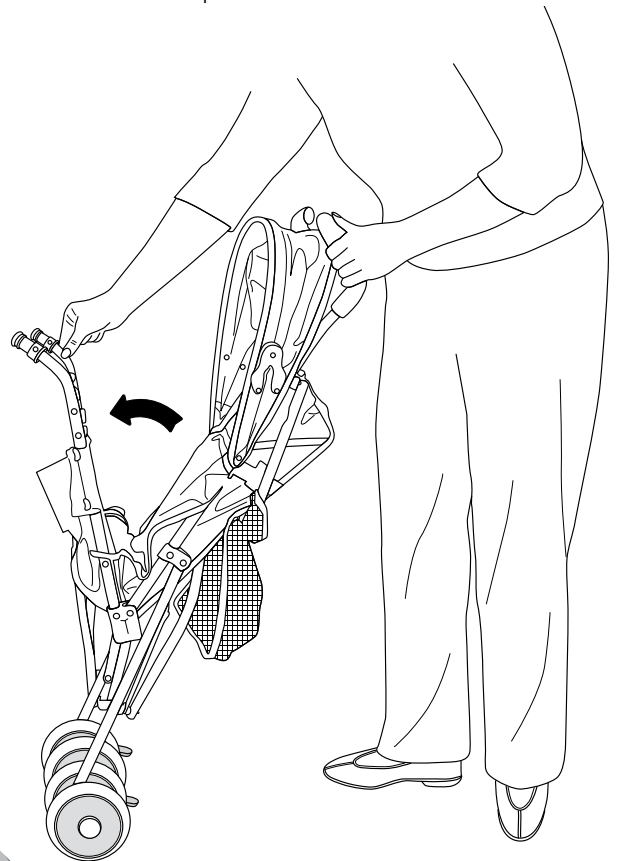

- Position the stroller upright on its rear wheels.
- Grasp a handle with one hand. With your other hand, push down on the front of the stroller to open.

Assembly

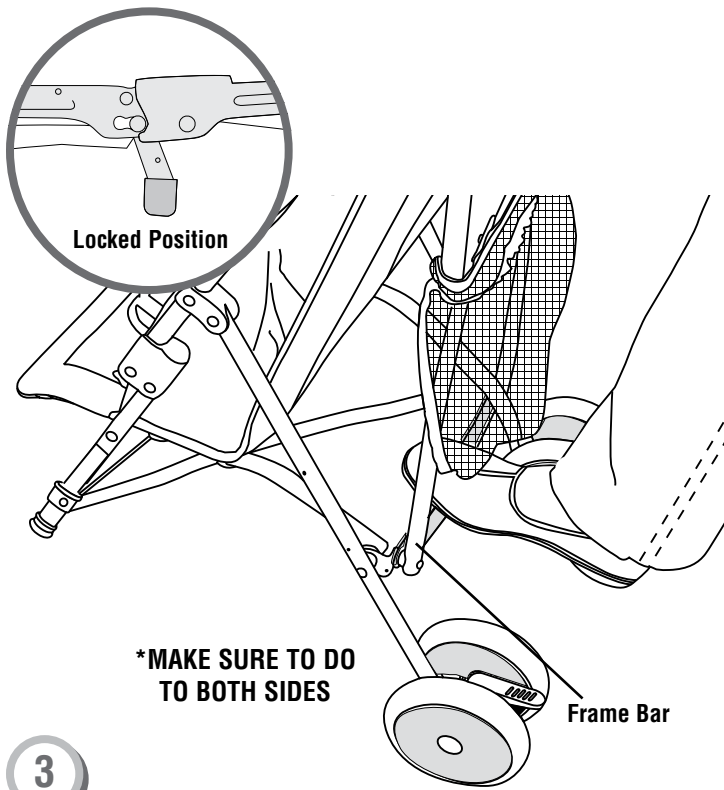

3

- With your foot, press down on the frame bar until it “clicks” into place.
- Check to be sure the stroller is locked open by pulling up on the frame bar.

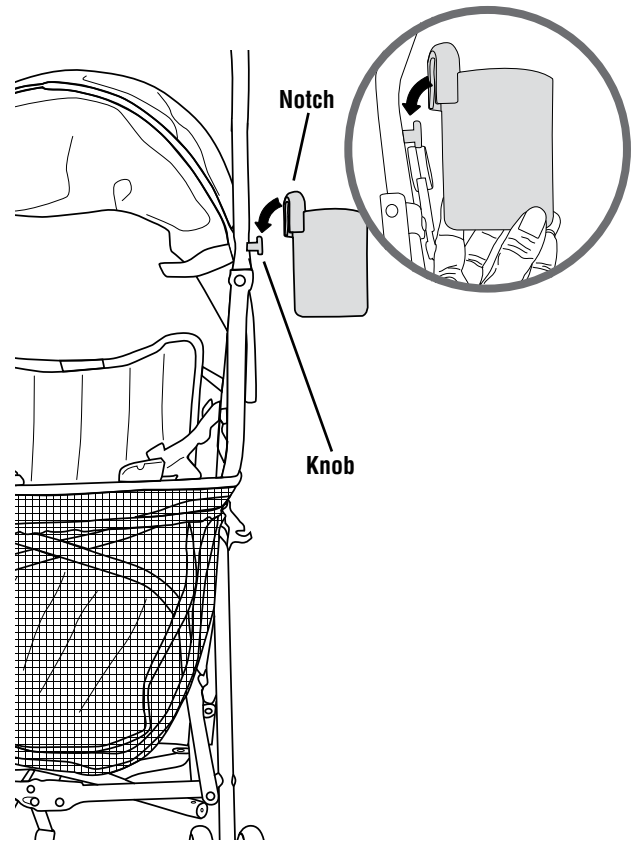

5

Attaching Cup Holder

- Locate the knob on the side of the stroller.
- Fit the notch in the cup holder over the knob on the side rail and push down until you hear a “click”. Pull up on the cup holder to be sure it is secure.

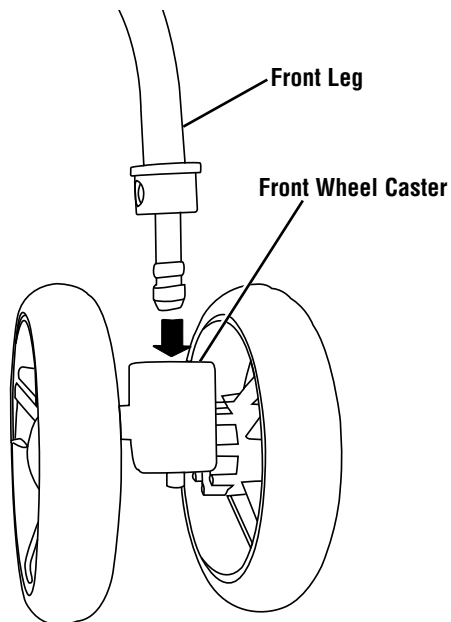

4

Front Wheel Assembly

- Slide the front wheel caster onto a front leg. Make sure you hear a “click”.
- Pull on the front wheel assembly to make sure it is securely attached to the front leg.
- Repeat this procedure to attach the other front wheel assemblies.

Setup and Use

WARNING

Prevent serious injury from falls or sliding out:

- ALWAYS use the restraint system.
- Only children who have developed enough upper body control to sit without leaning forward can use the front seat in the upright position.
- NEVER leave child unattended.
- DO NOT use the storage bag to carry children.

To prevent product from tipping over:

- DO NOT exceed the maximum storage weight limit of 3 lbs (1.36 kg) in the storage bag or canopy pouch.
- DO NOT exceed the maximum storage weight limit of 3 lbs (1.36 kg) in the cupholder.
- DO NOT place additional items on this product, except as recommended in the instructions.

To prevent injury:

- Make sure all body parts are clear of the stroller when folding and unfolding.
- DO NOT place hot liquids in the cup holder. Hot liquids can burn your child.

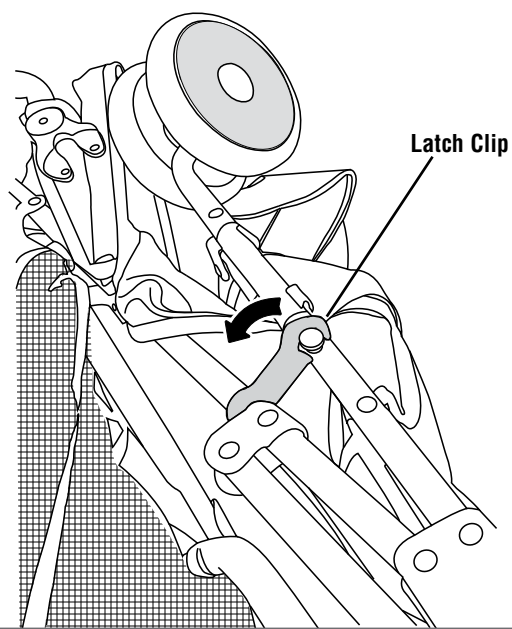

To Unfold

- Locate the latch clip on the side of the stroller.
- Pull to release the latch clip on the side of the stroller.

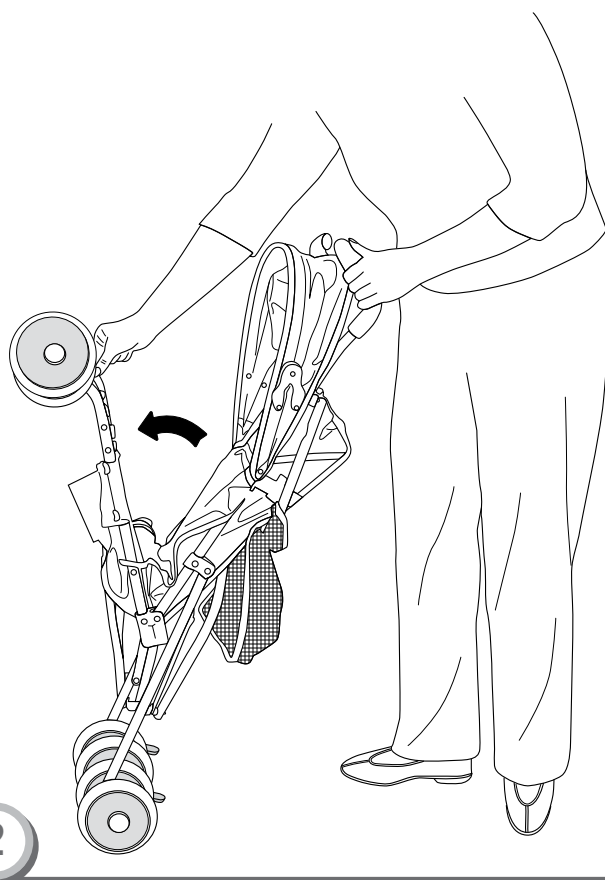

- Grasp a handle with one hand. With your other hand, push down on the front leg. Pull the stroller apart.

Setup and Use

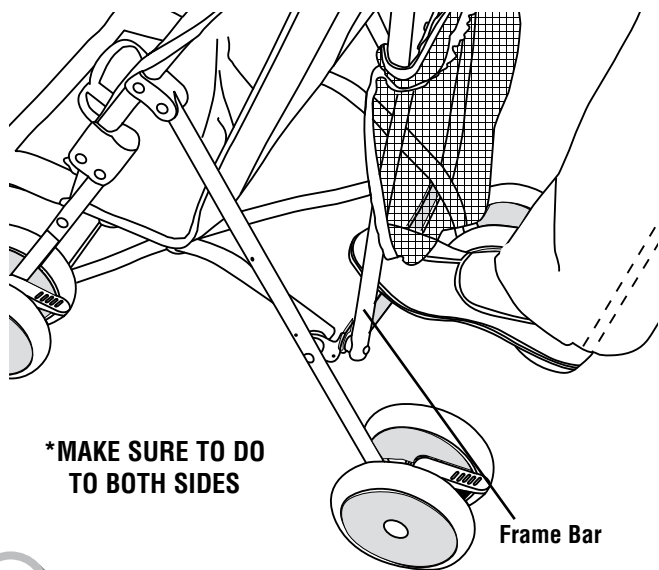

3

- With your foot, press down on the frame bar until it “clicks” into place.
- Pull up on the frame bar to make sure it is locked.

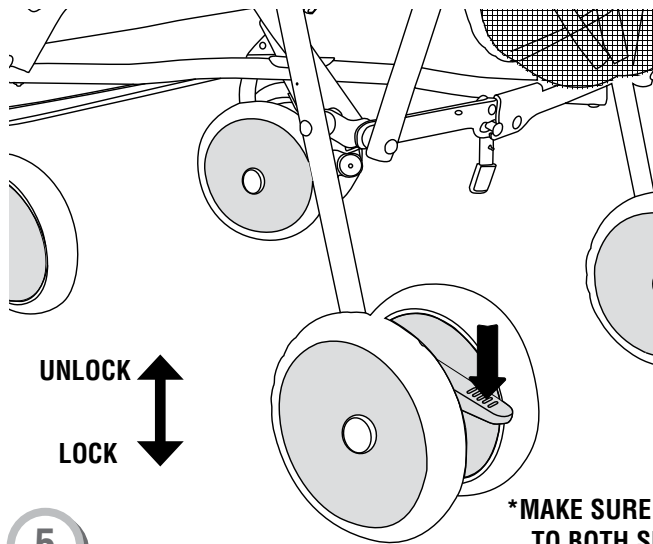

5

Rear Wheel Brakes

To lock the rear wheel brakes:

- Press **both** brake pedals down until they “click” into the locked position. **Make sure the brake pedals are pressed down completely.**
- Always set both brake pedals whenever you park the stroller.

To unlock the rear wheel brakes:

- Lift both brake pedals until they “click” into the unlocked position.

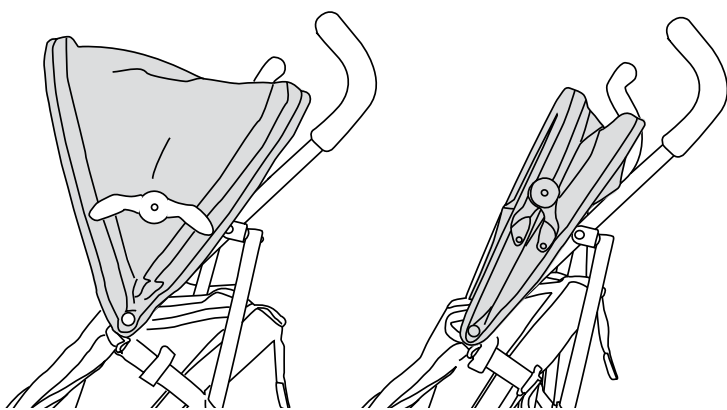

4

CANOPY OPEN

CANOPY CLOSED

Canopy Adjustment

- The canopy can be adjusted to the open or closed position.

SECURING CHILD

Before Placing your Child in Stroller:

Close Canopy. Press both brake pedals down until they “click” into the locked position.

Make sure the brake pedals are pressed down completely.

Always set both brake pedals when parking the stroller.

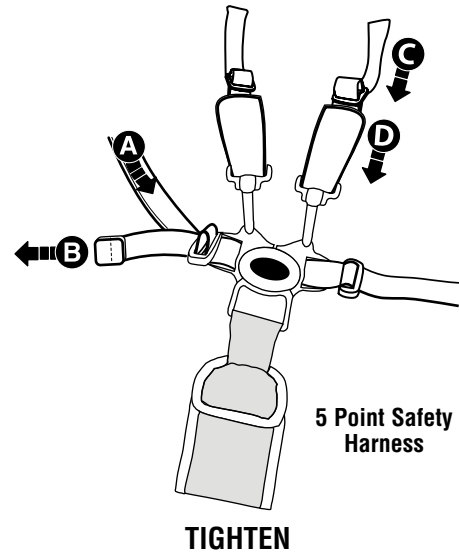
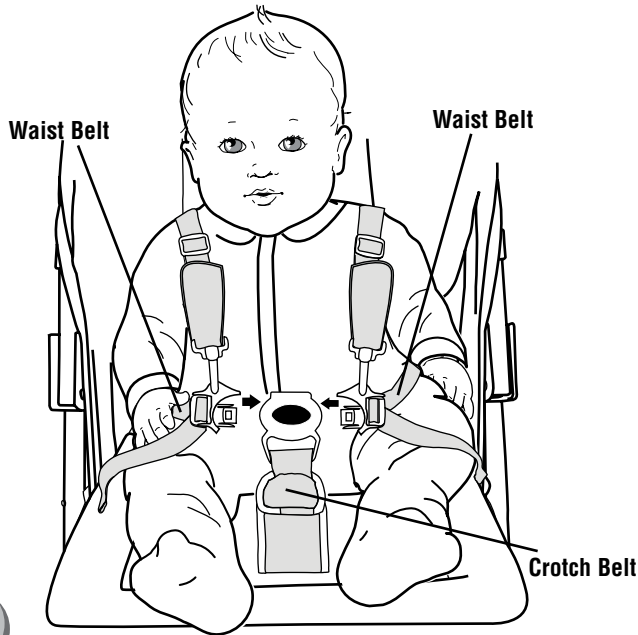

Securing Child

- Place your child in the stroller. Position the crotch belt between your child's legs.
- Pull shoulder straps over child's arm and shoulder and fasten **both** strap ends to the restraint system.
- Fasten **both** waist belts to the buckle on each side of the crotch belt. Make sure you hear a “click” on both sides.
- Check to be sure the restraint system is securely attached by pulling it away from your child. The restraint system should remain attached.

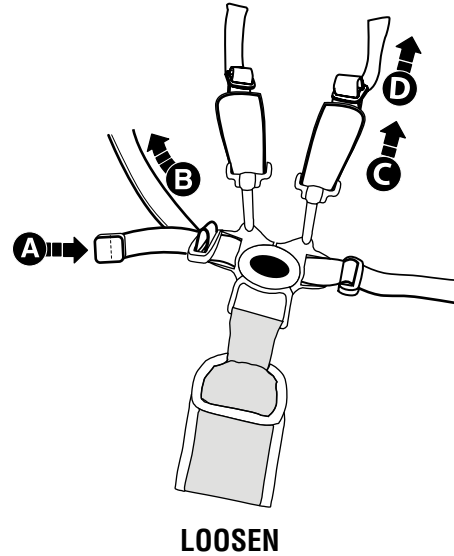

3

To tighten the waist belts and shoulder straps:

- Feed the anchored end of a waist belt up through the buckle to form a loop **A**. Pull the free end of the waist belt **B**.
- Repeat this procedure to tighten the other waist belt.
- Feed the top end of the shoulder strap through the plastic stay to form a loop **C**. Pull the bottom end down to tighten the strap **D**.
- Repeat this procedure to tighten the other shoulder strap.

To loosen the waist belts and shoulder straps:

- Feed the free end of the waist belt up through the buckle to form a loop **A**. Enlarge the loop by pulling on the end of the loop toward the buckle. Pull the anchored end of the waist belt to shorten the free end of the waist belt **B**.
- Repeat this procedure to loosen the other waist belt.
- Feed the bottom end of the shoulder strap through the plastic stay to form a loop **C**. Pull the top end up to loosen the strap **D**.
- Repeat this procedure to loosen the other shoulder strap.

Please note: After adjusting the restraint system to fit your child, make sure you pull on it to be sure it is securely fastened.

- Tighten each waist belt and shoulder strap so that the restraint system is snug against your child.

Please refer to the next section for instructions to tighten the waist belts.

Storage

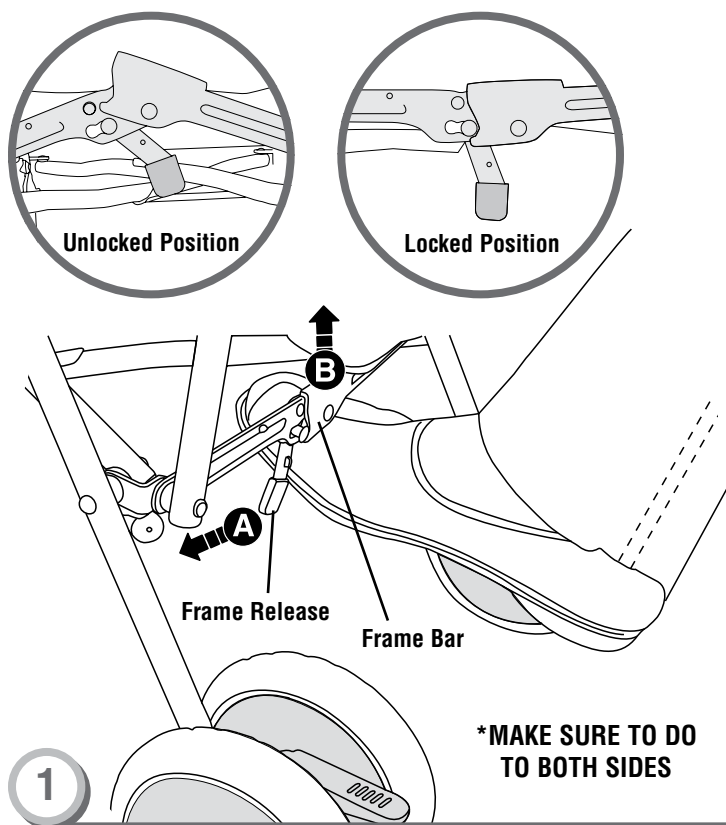

Hint: Make sure canopy is in the closed position before folding the stroller.

- With your foot, slide the frame release to the left **A**, then push up on the frame bar **B**.

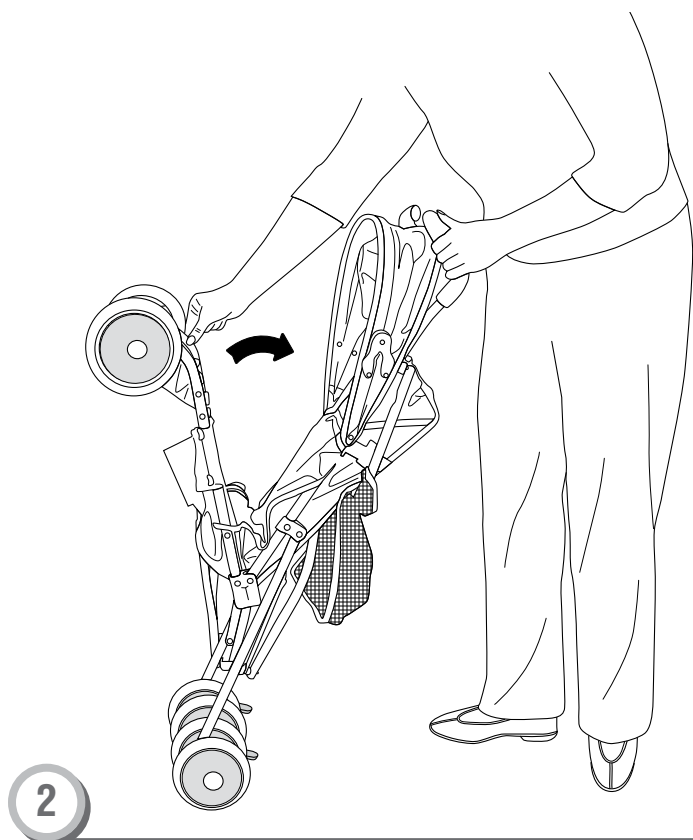

- Lift the front wheels toward the closed canopy.

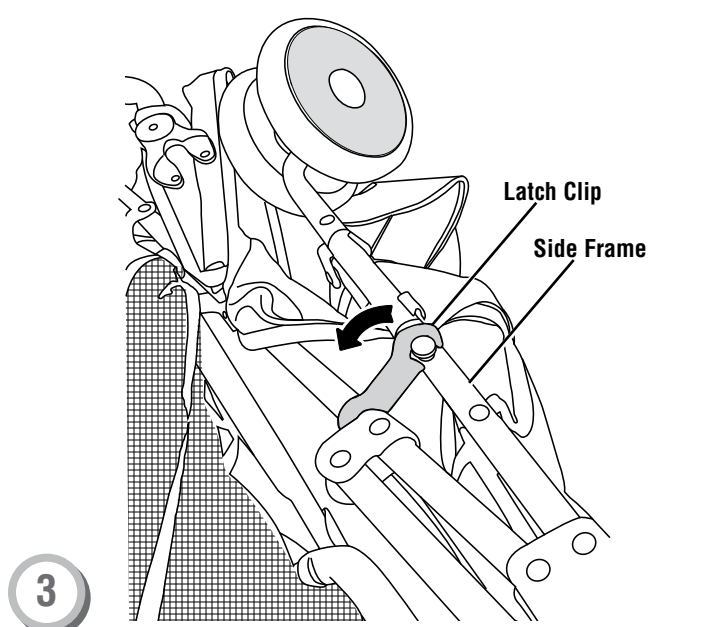

- Slide the latch clip onto the side frame to secure in the folded storage position.

Notes

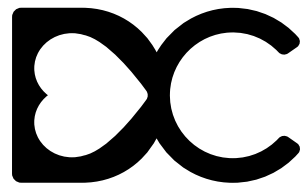

DELTACHILDREN

Delta Children's Products Corp.

114 West 26th Street
New York, NY 10001
gcs@DeltaChildren.com
www.DeltaChildren.com