

# CLASSIC TOUR STROLLER



## INSTRUCTION MANUAL

**ADULT ASSEMBLY REQUIRED**  
**THIS PRODUCT CONTAINS SMALL PARTS**  
**STYLES AND COLORS MAY VARY**

**LF11308**



**▲ WARNING:**  
**CHOKING HAZARD**

Adult assembly required because of small parts. Keep assembly parts out of reach of children under 3 years.

**Read all instructions BEFORE assembly and USE of product. KEEP INSTRUCTIONS FOR FUTURE USE.**



**Please DO NOT return this product to the store.**

If you experience any difficulty with assembly, missing parts or use, please DO NOT return this item to the store. Retail stores are unable to properly assist you. Contact our Customer Service Department directly for assistance

(646) 435-8726

www.DeltaChildren.com • gcs@deltachildren.com  
©2019 Delta Children's Products, Inc. New York, NY 10001



## **EXTENDED WARRANTY**

**DON'T MISS YOUR CHANCE TO BE COVERED FOR ALL OF LIFE'S MISHAPS!**

With Delta's Extended Warranty, you're covered for mechanical failure from normal use or if your item stops working due to normal wear and tear, plus all those unexpected surprises.

## **2 YEARS OF PROTECTION**

**For Additional Information:**

**Simply visit our Website, register your product, and add the Extended Warranty**

**<https://www.deltachildren.com/pages/product-registration>**

Extended Warranty only available in the following States: Arkansas, Colorado, Delaware, District of Columbia, Georgia, Idaho, Illinois, Indiana, Iowa, Kansas, Kentucky, Louisiana, Maryland, Michigan, Mississippi, Missouri, Nebraska, Nevada, New Hampshire, New York, North Carolina, North Dakota, Pennsylvania, Rhode Island, South Dakota, Tennessee, Utah, West Virginia

# WARNING

**WARNING:** Please follow all of these instructions to ensure the safety of your child. Keep these instructions for future reference.

**WARNING:** Failure to follow these instructions could result in serious injury or death. Avoid serious injury from falling or sliding out. Always use the safety harness and insure that the child is properly positioned according to these instructions.

**WARNING:** Never leave child unattended.

**WARNING: CHOKING HAZARD**

Adult assembly required because of small parts.

Keep (assembly parts) out of reach of children under 3 years.

Purses, shopping bags, parcels, diaper bags or accessory items may change the balance of the stroller and cause hazardous unstable conditions.

The maximum weight that can be carried in the basket is 3 lbs and in the parent tray is 3 lbs. Excessive weight may cause a hazardous unstable condition to exist.

Be certain the stroller is fully erect and latched in the open position before allowing the child near the stroller.

Use of the stroller with a child weighing more than 40 pounds or 40 inches will cause excessive wear and stress on the stroller and may cause a hazardous unstable condition to exist.

**DO NOT** use the stroller on stairways or escalators.

**DO NOT** use the stroller with roller skates or in-line skates.

Never allow your stroller to be used as a toy.

To clean use only mild household soap or detergent and warm water on a sponge or clean cloth.

Check your stroller for loose screws, worn parts, torn material or stitching on a regular basis. Replace or repair parts as needed.

Discontinue use of stroller should it malfunction or become damaged. Please contact our customer service Parts Hotline to arrange for repair or obtain replacement parts.

## CARE AND MAINTENANCE

- To clean the stroller use a mild household soap with warm water on a sponge or clean cloth.
- Check your stroller for loose screws, worn parts, torn material or stitching on a regular basis. Replace or repair parts as needed.
- Discontinue use of stroller if it should become damaged or malfunctions. Please contact our customer service number (646) 435-8726 to arrange for repair or obtain replacement parts.
- If you experience any difficulty with assembly, missing parts or use, please DO NOT return this item to the store. Retail stores are unable to properly assist you. Contact our Customer Service Department directly for assistance (646) 435-8726.

# PARTS

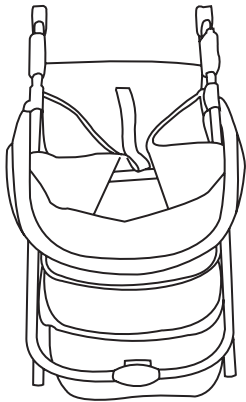

**Stroller**

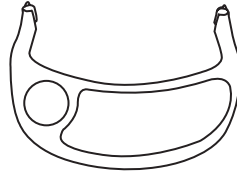

**Child Tray**



**Parent Tray**

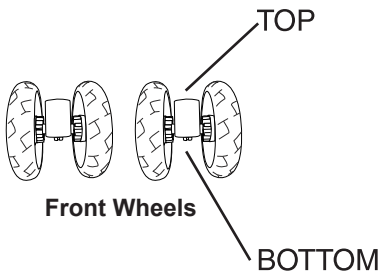

**Front Wheels**



**Rear Wheels**



**Locking Clips**



**Rear Wheel Axle**



**Hub Caps**



**Washer**

# ASSEMBLY

**ATTENTION:** To ensure safe operation of your stroller, please follow these instructions carefully. Retain these instructions for future reference. Remove stroller from box. The front wheels, rear wheels, child tray and parent tray need to be installed prior to use.

Remove stroller from box. The front wheels, rear wheels, child tray and parent tray need to be installed prior to use.

## FRONT WHEEL

1. Release the folding latch lock, which is located on the right side.
  - Lift up the stroller handle with both hands (Fig. 1a) until the stroller frame is vertical and fully locked in the upright position before use. See Figure 1b.

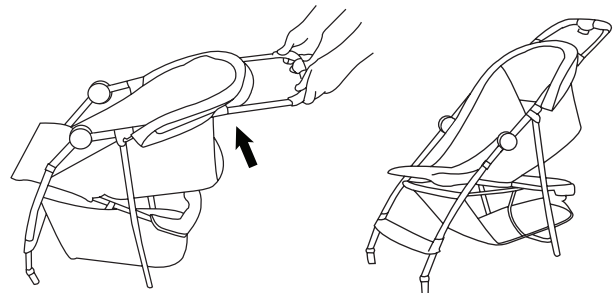

Fig. 1a

Fig. 1b

2. Lean the stroller backwards so that it rests on the handle and rear frame tubes and the front wheel posts are pointing upward.
  - Push each front wheel onto the front wheel posts until snapped into place. (Fig 2) Pull on the wheel to ensure that it is securely attached to the stroller.

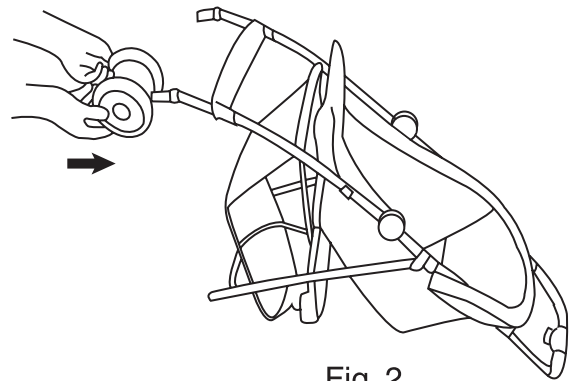

Fig. 2

## REAR WHEEL

3. Assemble the rear axle as follows. Insert the axle through each wheel, with axle going through the brake cluster on the wheel first. Then slide washer onto axle. (Fig 3a) Secure the wheel with the locking clip by pushing the straight side of pin through axle hole. (Fig 3b). Snap wheel cap into place (Fig 3c). Pull on each wheel to ensure that each is securely locked onto the rear axle.

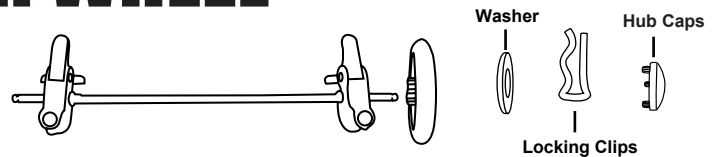

Fig. 3a

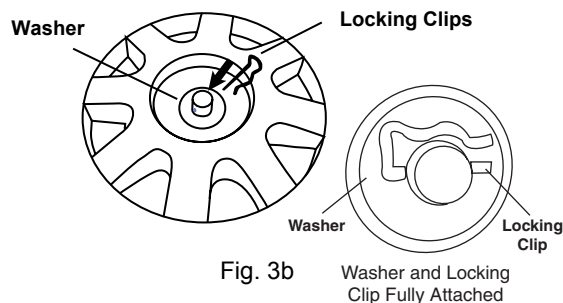

Fig. 3b

Fig. 3c

# ASSEMBLY

## ATTENTION

PLEASE FOLLOW THESE INSTRUCTIONS FOR THE PROPER INSTALLATION OF YOUR REAR AXLE ASSEMBLY

4. Lean the stroller forward to rest on the front wheels. To attach the rear axle, line up the rear frame tubes with the rear axle housing with the brake pedals facing toward the rear of the stroller. Push both housings onto the rear frame tubes at the same time until they snap into place. Check that the push button shows through the small hole near the bottom of the inside of the housing. (Fig 4) Make sure that the axle is firmly attached to the stroller. (For more details see page 18)

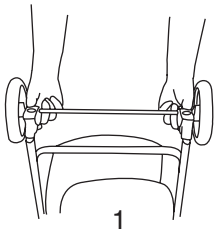
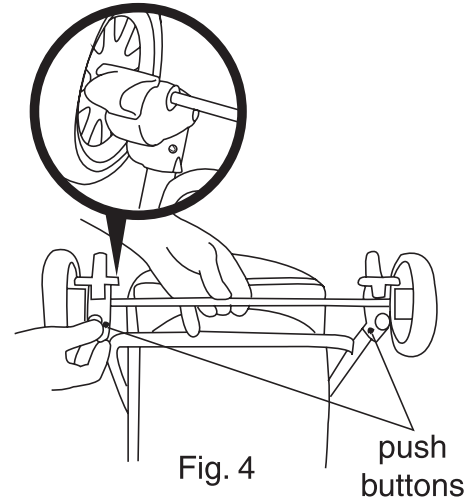

1  
Line up the frame tubes with the axle assembly

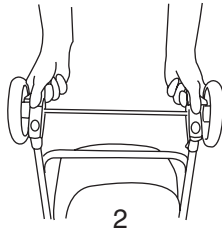

2  
Slide onto frame tubes at the same time

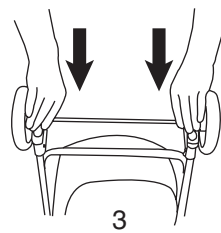

3  
Push down until axle housing snaps into place

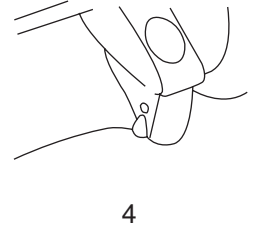

4  
Axle housing is secure when the metal tab locks axle housing into place

### TO ATTACH THE REAR WHEELS

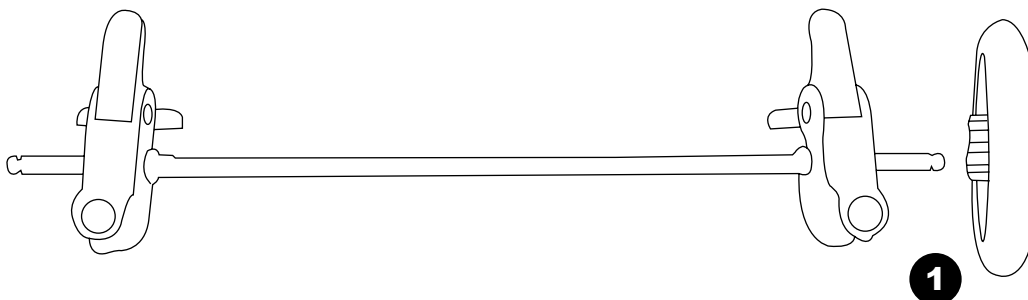

Follow this order

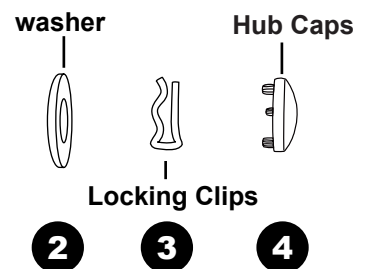

# ASSEMBLY

**WARNING:** Do Not lift the stroller by the front tray.

## CHILD TRAY

5. To attach the front child tray, snap each side latch onto the front frame tube just below the fold joint and above the tray stop. Please see Figure 5a.

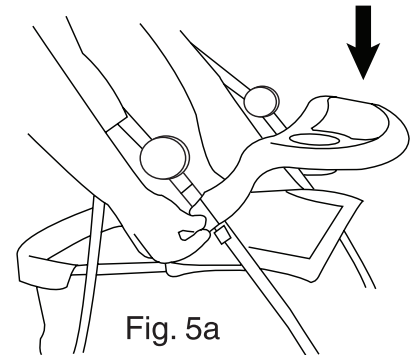

- To remove front child tray pull outward on the tray latches to release. Please see Figure 5b.

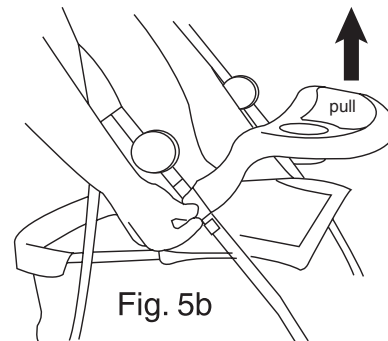

- To unload child, unlatch one side of child tray, and swing outward. Please see Figure 5c.

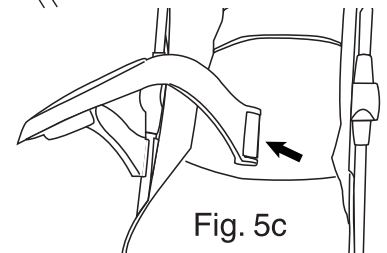

6. To attach the parent tray, place one side of the tray on the stroller handle such that the button engages into the hole on the tray. Snap opposite side onto handle checking that the button engages into the hole on the tray. Please see Figure 6.

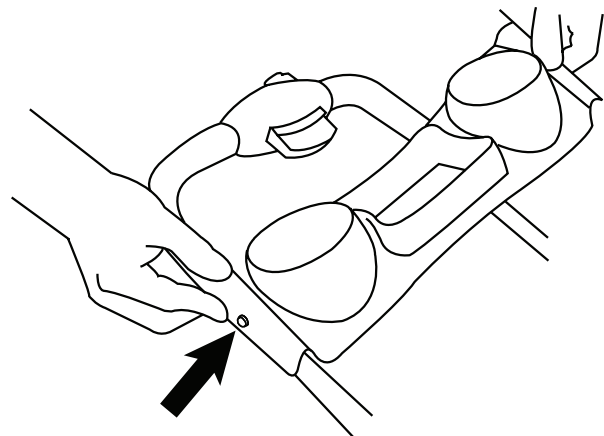

# TO SECURE THE CHILD

## Before Placing your Child in Stroller:

Close Canopy. Press both brake pedals down until they “click” into the locked position.

**Make sure the brake pedals are pressed down completely.**

Always set both brake pedals when parking the stroller.

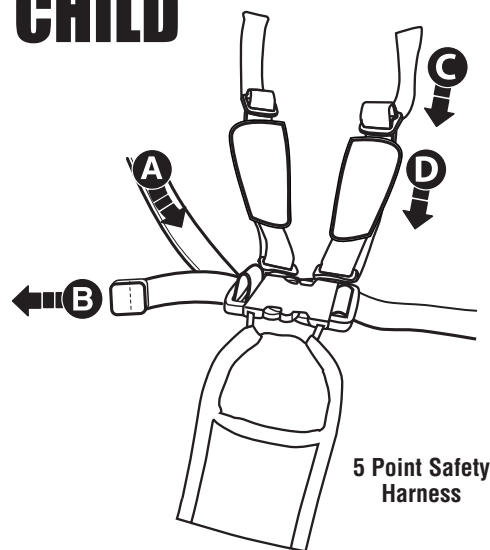

5 Point Safety Harness

**TIGHTEN**

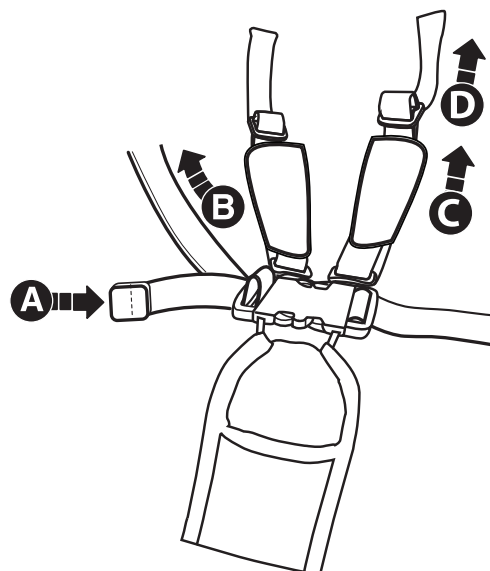

**LOOSEN**

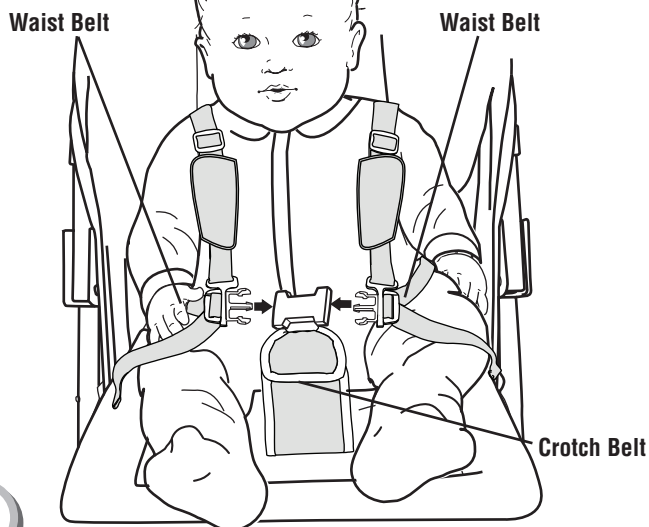

1

## Securing Child

- Place your child in the stroller. Position the crotch belt between your child's legs.
- Pull shoulder straps over child's arm and shoulder and fasten **both** strap ends to the restraint system.
- Fasten **both** waist belts to the buckle on each side of the crotch belt. Make sure you hear a “click” on both sides.
- Check to be sure the restraint system is securely attached by pulling it away from your child. The restraint system should remain attached.

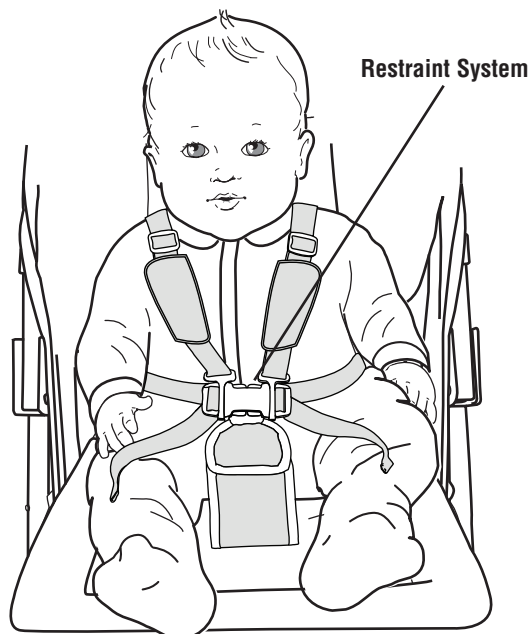

2

- Tighten each waist belt and shoulder strap so that the restraint system is snug against your child.

Please refer to the next section for instructions to tighten the waist belts.

3

## To tighten the waist belts and shoulder straps:

- Feed the anchored end of a waist belt up through the buckle to form a loop **A**. Pull the free end of the waist belt **B**.
- Repeat this procedure to tighten the other waist belt.
- Feed the top end of the shoulder strap through the plastic stay to form a loop **C**. Pull the bottom end down to tighten the strap **D**.
- Repeat this procedure to tighten the other shoulder strap.

## To loosen the waist belts and shoulder straps:

- Feed the free end of the waist belt up through the buckle to form a loop **A**. Enlarge the loop by pulling on the end of the loop toward the buckle. Pull the anchored end of the waist belt to shorten the free end of the waist belt **B**.
- Repeat this procedure to loosen the other waist belt.
- Feed the bottom end of the shoulder strap through the plastic stay to form a loop **C**. Pull the top end up to loosen the strap **D**.
- Repeat this procedure to loosen the other shoulder strap.

**Please note:** After adjusting the restraint system to fit your child, make sure you pull on it to be sure it is securely fastened.



# OPERATION

## SEAT BACK RECLINE POSITIONING

9. Squeeze both sides on cord housing and pull away to recline seat, as shown in Fig. 9.

To return to an upright position, hold bottom cord loops while squeezing cord housing and move cord housing upwards towards the backseat, as shown in Fig. 9A.

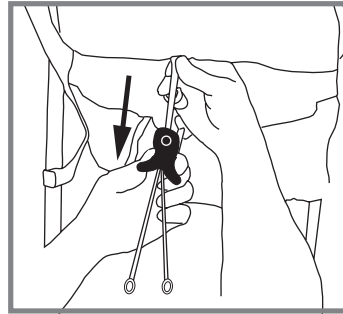

RECLINE

Fig. 9

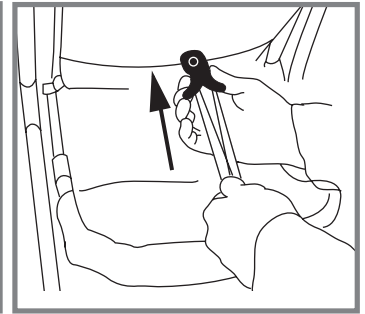

UPRIGHT

Fig. 9A

## BRAKES

**WARNING:** Always set brakes when the stroller is not being pushed so that the stroller will not roll away. Never leave stroller unattended on a hill or incline as the stroller may slide down the hill.

10. To engage brakes, apply light downward pressure to the brake lever located on each rear wheel. See Figure 10a. The stroller may require slight forward or rearward movement in order to line up the teeth on the brake with each wheel brake cluster. Check that the stroller will not move and that the brakes are properly applied. To release, gently lift up on the brake lever. See Figure 10b.

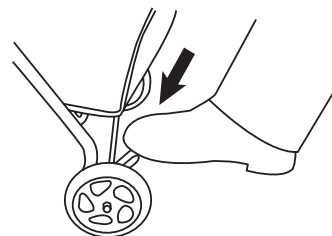

Fig. 10a

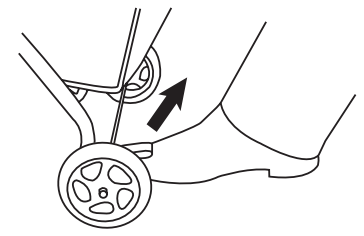

Fig. 10b

# OPERATION

## CANOPY

11. To open the canopy, push forward on the front frame of the canopy. Pull backwards on the canopy frame to fold completely. Always fold the canopy prior to folding the stroller frame. Please see Figure 11.

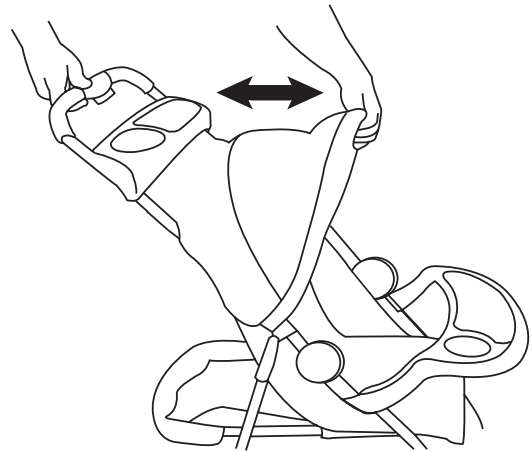

Fig. 11

## TO FOLD STROLLER

12. **NOTE:** Make sure canopy is in its fully closed position and recline the seat to a fully reclined down position before folding the stroller.

To fold the stroller, the following needs to be completed; close canopy and recline the seat to a fully reclined position. (Fig. 12)

A **Dual action** is needed to fold the stroller.

**Action 1;** Slide the unlock tab with your thumb to the farthest left position and hold.

**Action 2;** While holding unlock tab, squeeze the fold lever inward and push downward on the handle. (Fig. 12A) (Fig. 12B)

Once the stroller begins to fold, release the unlock tab and push downward until stroller is folded. Secure the stroller in the folded position by fastening the fold locking latch (located on the right side of the stroller) over the extended rivet on the lower frame tube. (Fig. 12C)

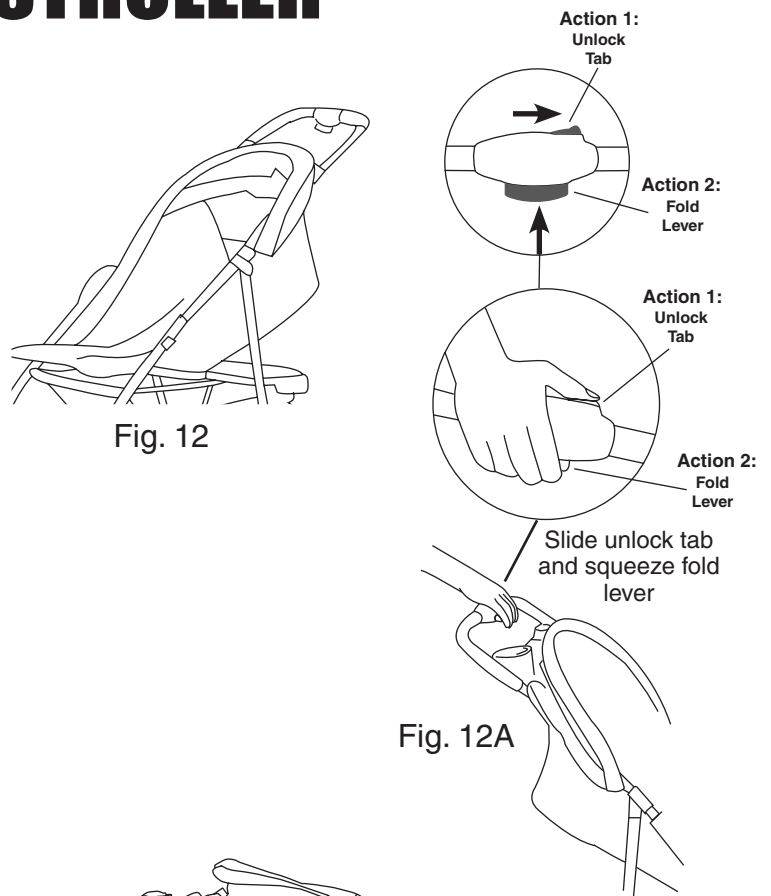

Fig. 12

Fig. 12A

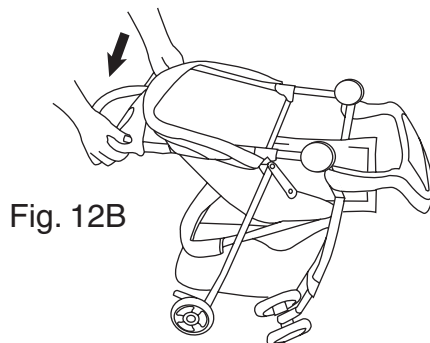

Fig. 12B

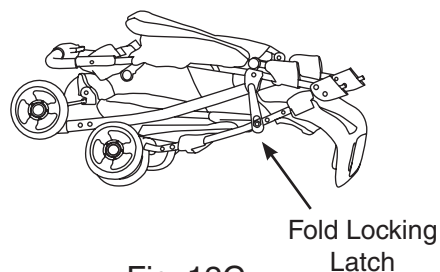

Fig. 12C





**Delta Children's Products Corp.**  
114 West 26th Street  
New York, NY 10001  
(646) 435-8726  
[www.DeltaChildren.com](http://www.DeltaChildren.com)