



Read all instructions before assembly and use.
KEEP INSTRUCTIONS FOR FUTURE USE.

Lisez toutes les instructions avant l'assemblage et l'utilisation.
CONSERVEZ LES INSTRUCTIONS POUR UN USAGE ULTERIEUR.

Lea todas las instrucciones antes de ensamblar y usar.
MANTENGA LAS INSTRUCCIONES PARA SU USO FUTURO.



Loft Bed
Lit Mezzanine
Cama Litera

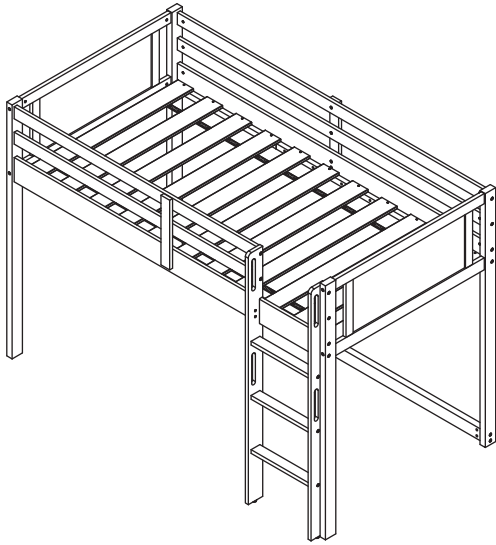

ADULT ASSEMBLY REQUIRED

Due to the presence of small parts during assembly, keep out of reach of children until assembly is complete.

L'ASSEMBLAGE DOIT ETRE FAIT PAR UN ADULTE

A cause de la presence de petites pieces, pendant l'assemblage gardez hors de portee des enfants jusqu'a ce que celui-ci soit termine.

DEBE SER ENSAMBLADO POR UN ADULTO

Debido a la presencia de piezas pequeñas durante el ensamblaje, mantenga fuera del alcance de los niños hasta que complete el ensamblaje.

This product is not intended for institutional or commercial use.
Ce produit ne pas destine a un usage institutionnel ou commercial.
Este producto no esta hecho para uso institucional o comercial.

NEED EXTRA HELP?

We make assembly easy with our tips & tricks video

<https://www.deltachildren.com/pages/instructions>

BESOIN D'AIDE SUPPLÉMENTAIRE?

Nous facilitons l'assemblage avec nos trucs et astuces vidéo

<https://www.deltachildren.com/pages/instructions>

¿NECESITA AYUDA EXTRA?

Hacemos el montaje fácil con nuestros consejos y trucos video

<https://www.deltachildren.com/pages/instructions>

When contacting Delta Consumer Care, please reference the information on the Product Information label found on the product.

Lorsque vous contactez le Service après Vente de Delta, veuillez nous donner les références sur l'étiquette d'Information qui se trouve sur le produit.

Cuando contacte al Servicio de Atención al Consumidor de Delta por favor mencione los datos que aparecen en la etiqueta de información que se encuentra en el producto.



DELTA CHILDREN'S PRODUCTS CORP
114 WEST 26TH STREET. M / #: xxxxx
NEW YORK, NY 10001. PO #: xxxxx LOT #: xxxxx
Email: tcs@DeltaChildren.com D. O. M.: xxxxx
TEL.: 646-435-8728 Base Model: BW301
MADE IN MALAYSIA TSCA VI

Product information label
L'étiquette d'information
Etiqueta de información

Consumer Care:

Delta Children's Products Corp
114 West 26th Street New York, NY 10001
Tel: (646) 435-8728

Email: tcs@DeltaChildren.com

<https://www.deltachildren.com/pages/instructions>





SAVE BIG WITH DELTA CHILDREN

Visit Deltachildren.com To Start Shopping

Welcome to the
DELTA FAMILY
Here's a Gift From Us To You

10% OFF

Your Next Purchase From
DeltaChildren.com

USE CODE:
DELTA10

*Exclusions Apply
*Subject to Change

REVIEW TO WIN \$2500

RULES TO ENTER



"We LOVE, LOVE, LOVE this crib"

My husband was impressed with the directions and organization of the hardware package. He easily assembled this crib in an hour without any help. It's very sturdy and we like that it has adjustable levels for the mattress height. To top it all off, it's so incredibly darling!!!

- 1** **WRITE A REVIEW** for this product on the store's website from where it was purchased
- 2** **TAKE A SCREENSHOT** of your review and upload it to www.DeltaChildren.com/Review
- 3** **IT'S THAT EASY!** Upon submission, you'll be instantly **ENTERED TO WIN \$2,500**

FOLLOW US FOR MORE CHANCES TO WIN



SCAN HERE



For more information
and to see all of our
products





WARNING

- Follow the information on the warnings appearing on the upper bunk end structure and on the carton. **DO NOT** remove warning label from bed.
- Always use the recommended size mattresses or mattress supports, or both, to help prevent the likelihood of entrapment or falls.
- Surface of mattress must be at least 5". (127 mm) below the upper edge of guardrails.
- This bed is intended to use a twin size mattress that is between 74" - 75" long, between 37 1/2" - 38 1/2" wide, and not thicker than 8".
- **DO NOT** allow children under 6 years of age to use the upper bunk.
- Periodically check and ensure that the guardrail, ladder, and other components are in their proper position, free from damage, and that all connectors are tight.
- **DO NOT** allow horseplay on or under the bed and prohibit jumping on the bed.
- Use of a night light may provide added safety precaution for a child using the upper bunk
- **DO NOT** substitute parts. Replacement parts, including additional guardrails, may be obtained from Delta Children's Products dealers that carry this item or by contacting Delta Consumer Care.
- Always use the ladder for entering and leaving the upper bunk.
- Always use guardrails on both long sides of the upper bunk. If the bunk bed will be placed next to the wall, the guardrail that runs the full length of the bed should be placed against the wall to prevent entrapment between the bed and wall.
- The use of water or sleep flotation mattresses is prohibited.
- **STRANGULATION HAZARD**—Never attach or hang items to any part of the bunk bed that are not designed for use with the bed; for example, but not limited to, hooks, belts and jump ropes.
- Keep these instructions for future reference.



AVERTISSEMENT

- Suivez les informations des avertissements apparaissant sur l'extrémité du cadre du lit en hauteur et sur le carton. Ne pas retirer l'étiquette d'avertissement du lit.
- Toujours utiliser la taille de matelas ou support de matelas recommandés, ou les deux, pour prévenir le risque de piégage ou de chute.
- La surface de matelas doit être au moins 5 pouces. (127mm) en dessous du bord supérieur de la barre de sécurité.
- Ce lit est conçu pour recevoir un matelas double dont les dimensions sont de l'ordre de : 187,96 à 190,5 cm (74 à 75 pouces) de long, 95,25 à 97,79 cm (37 1/2 à 38 1/2 pouces) de large, et 20.32 cm (8 pouces) d'épaisseur maximum.
- **NE PAS** autoriser un enfant de moins de 6 ans utiliser le lit en hauteur.
- Fréquemment vérifier et s'assurer que la barre de sécurité, l'échelle, et les autres composants sont dans leurs positions correctes, sans dommage, et que tous les connecteurs sont serrés.
- **NE PAS** laisser l'enfant se mettre à cheval sur ou en dessous du lit et interdire de sauter sur le lit.
- **NE PAS** remplacer des pièces. Des pièces de rechange, y compris des rambardes de sécurité supplémentaires, sont disponibles auprès des magasins Delta Children's Products qui vendent cet article, ou en contactant le Service Client de Delta.
- Utiliser une lampe de nuit peut apporter une précaution de sécurité supplémentaire pour l'enfant utilisant le haut du lit.
- Toujours utiliser les barres de sécurité sur les deux côtés du lit en hauteur. Si le lit superposé sera placé à côté du mur, la barre de sécurité se trouvant près du mur devra être contre le mur pour prévenir le risque de piégage ou de chute.
- L'utilisation de matelas d'eau ou de flottaison est interdit.
- **RISQUE D'ÉTRANGLEMENT** - Ne jamais attacher ou laisser pendre des objets à n'importe quel endroit du lit superposé qui ne sont pas faits pour l'utilisation de ce lit; par exemple, mais ne se limite pas à ceci, crochets, ceintures et cordes à sauter
- Gardez ces instructions pour future référence.



ADVERTENCIA

- Siga las advertencias que aparecen en uno de los extremos de esta cama litera y en la caja de este producto. **NO** remueva la etiqueta de advertencia de la cama.
- Siempre utilice el tamaño recomendado de colchón o soporte o ambos, para prevenir posibles atrapamientos o caídas.
- Asegúrese de que el espesor del colchón esté al menos 5" debajo del borde superior de barandas.
- Esta cama está diseñada para usar colchones de 74" a 75" de largo y 37 1/2 " a 38 1/2" de ancho, y hasta 8" de espesor.
- **NO** permita que niños menores de 6 años utilicen la litera superior. Verifique periódicamente que las barandillas, escalera y otros componentes estén en la posición adecuada, libre de daños, y que todas las conexiones estén correctamente apretadas.
- **NO** permita juegos bruscos sobre o debajo de la cama.
- Use siempre la escalera para subir y bajar de la parte superior litera.
- **NO** sustituya piezas. Piezas de reemplazo, incluyendo barandas de seguridad, pueden ser obtenidas a través de los distribuidores de Delta Children que vendan este producto o comunicándose con Atención al Consumidor de Delta Children.
- Usar luz nocturna quizá proporcione seguridad adicional al niño que utilice esta cama litera.
- Siempre use barandas de seguridad en ambos lados largos de camas litera. Si la litera está colocada junto a la pared, las barandas de seguridad que recorre toda la cama debe colocarse contra la pared para evitar atrapamientos entre la cama y la pared.
- El uso de colchones de agua o colchones inflables está prohibido en esta cama.
- **PELIGRO DE ESTRANGULACIÓN**
NUNCA coloque o cuelgue artículos en ninguna parte de la cama litera que no sean diseñados para el uso esta; por ejemplo, pero no limitado a, ganchos, correas y cuerdas de saltar.
- Mantenga estas intrucciones para futuras referencias.

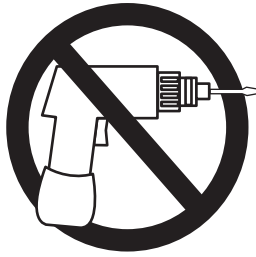

Required Tools
Outils Nécessaires
Herramientas necesarias



AA x16

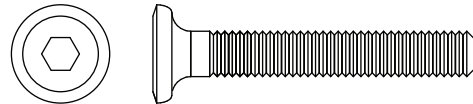

BB x2

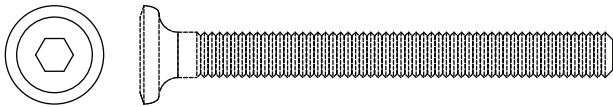

CC x10

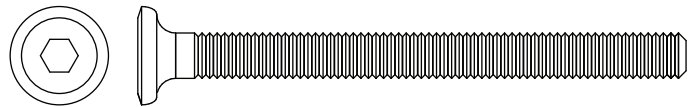

DD x18

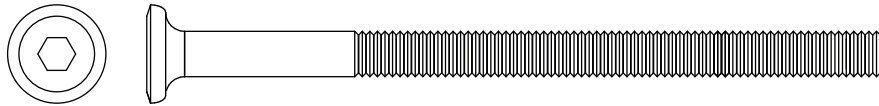

EE x8

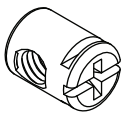

FF x36



GG x2

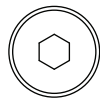

HH x8

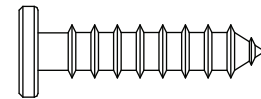

JJ x22

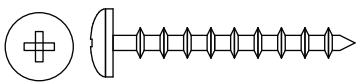
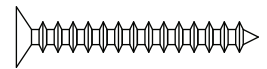

KK x2

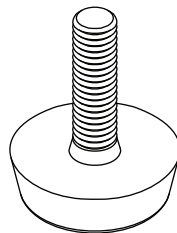

LL x2

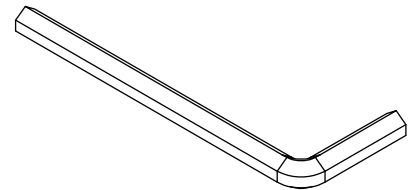

MM x2



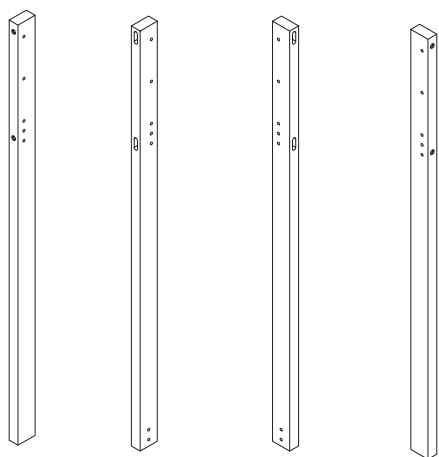

A x1 B x1 C x1 D x1

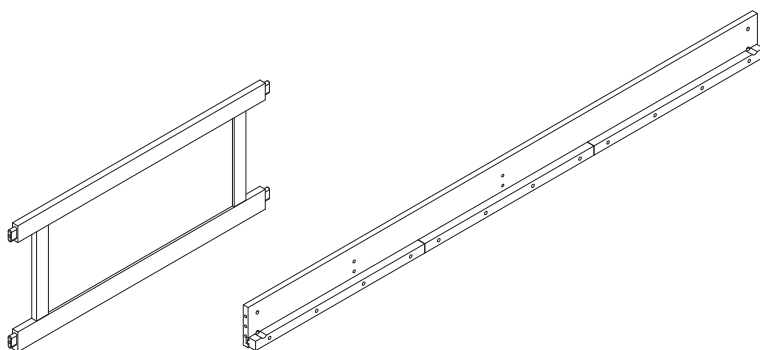

E x2 F x1

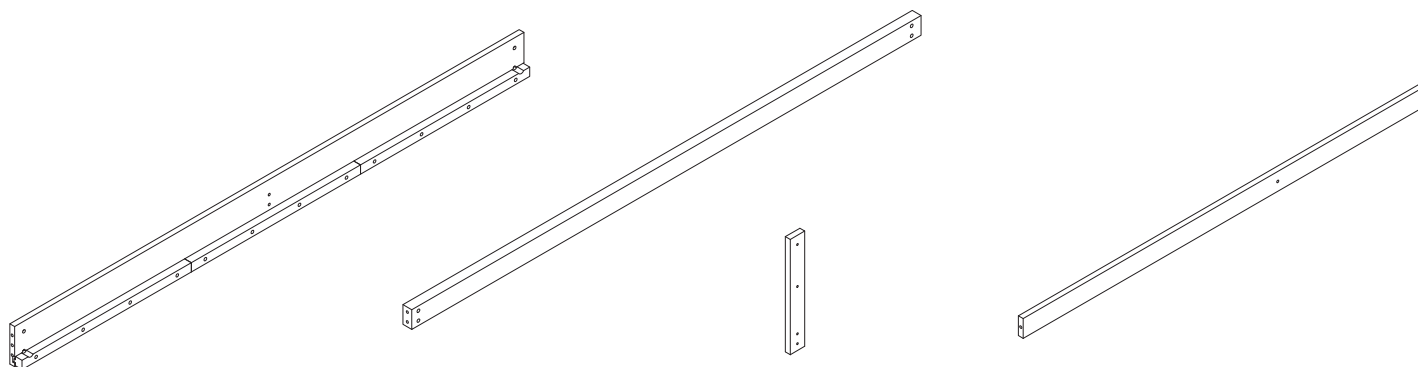

G x1 H x1 K x2 L x2

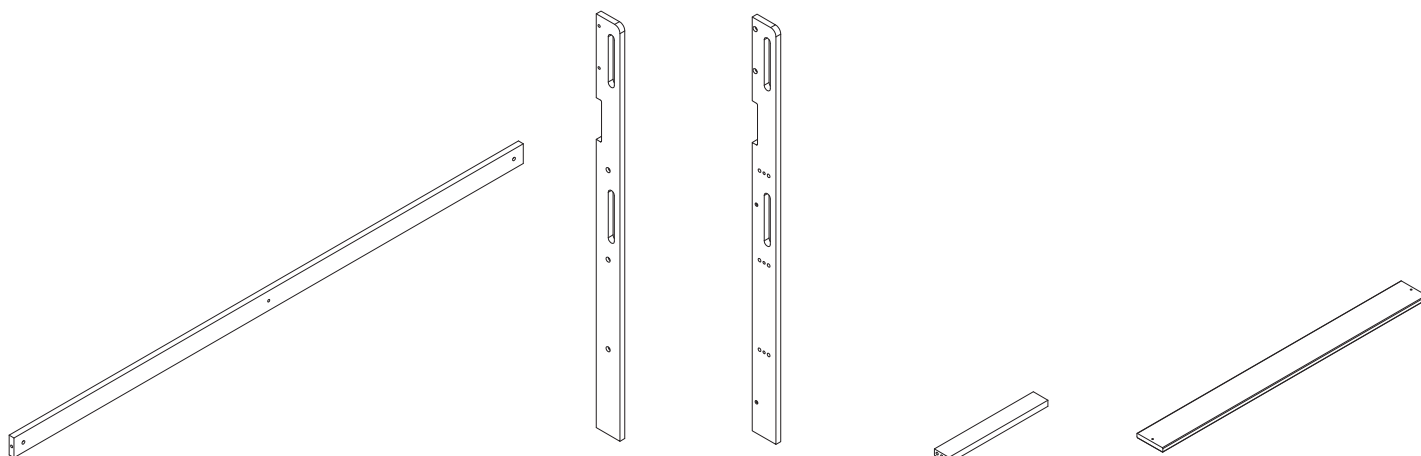

M x2 N x1 P x1 Q x3 R x11



1

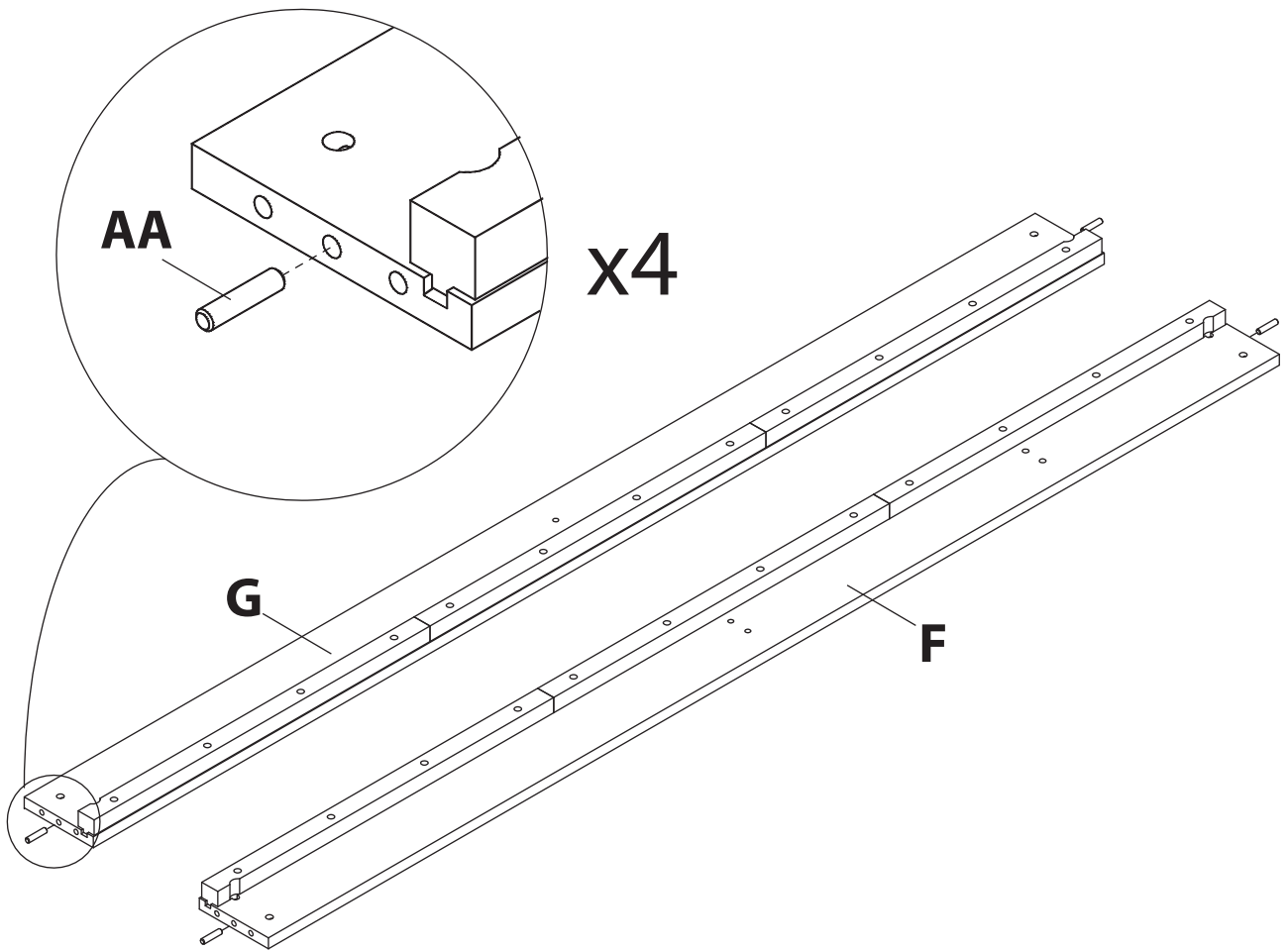
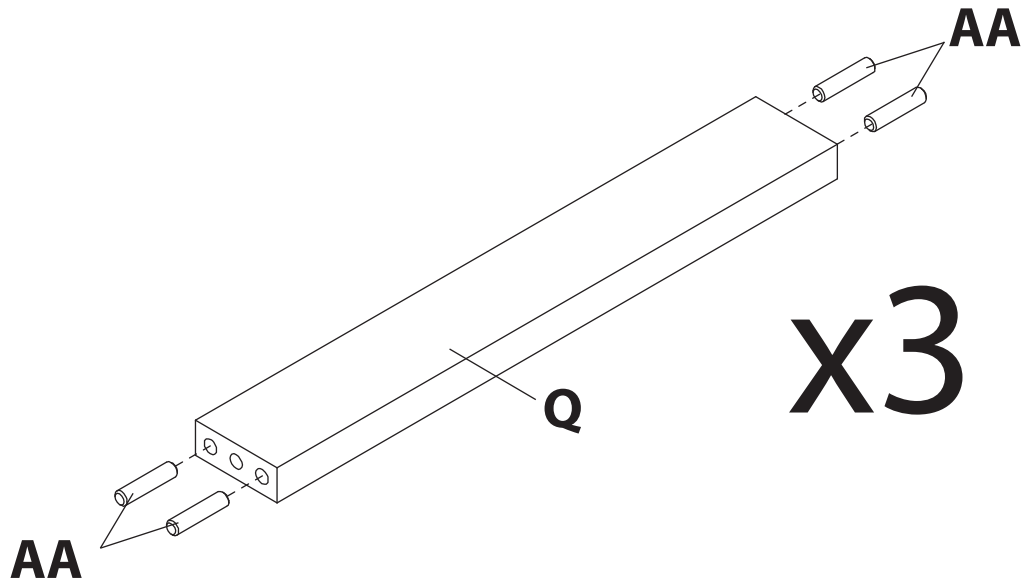



2

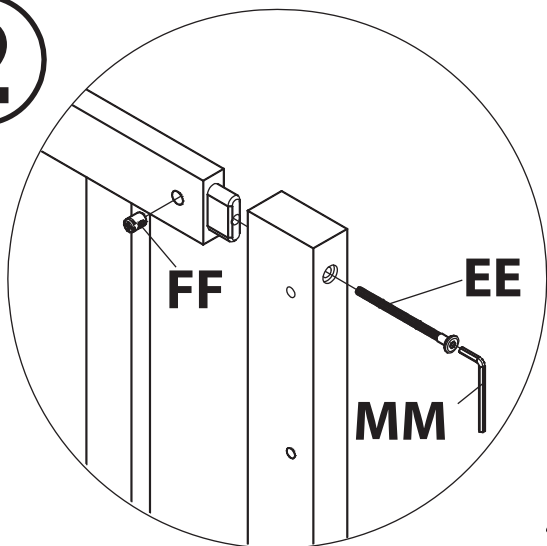

x8

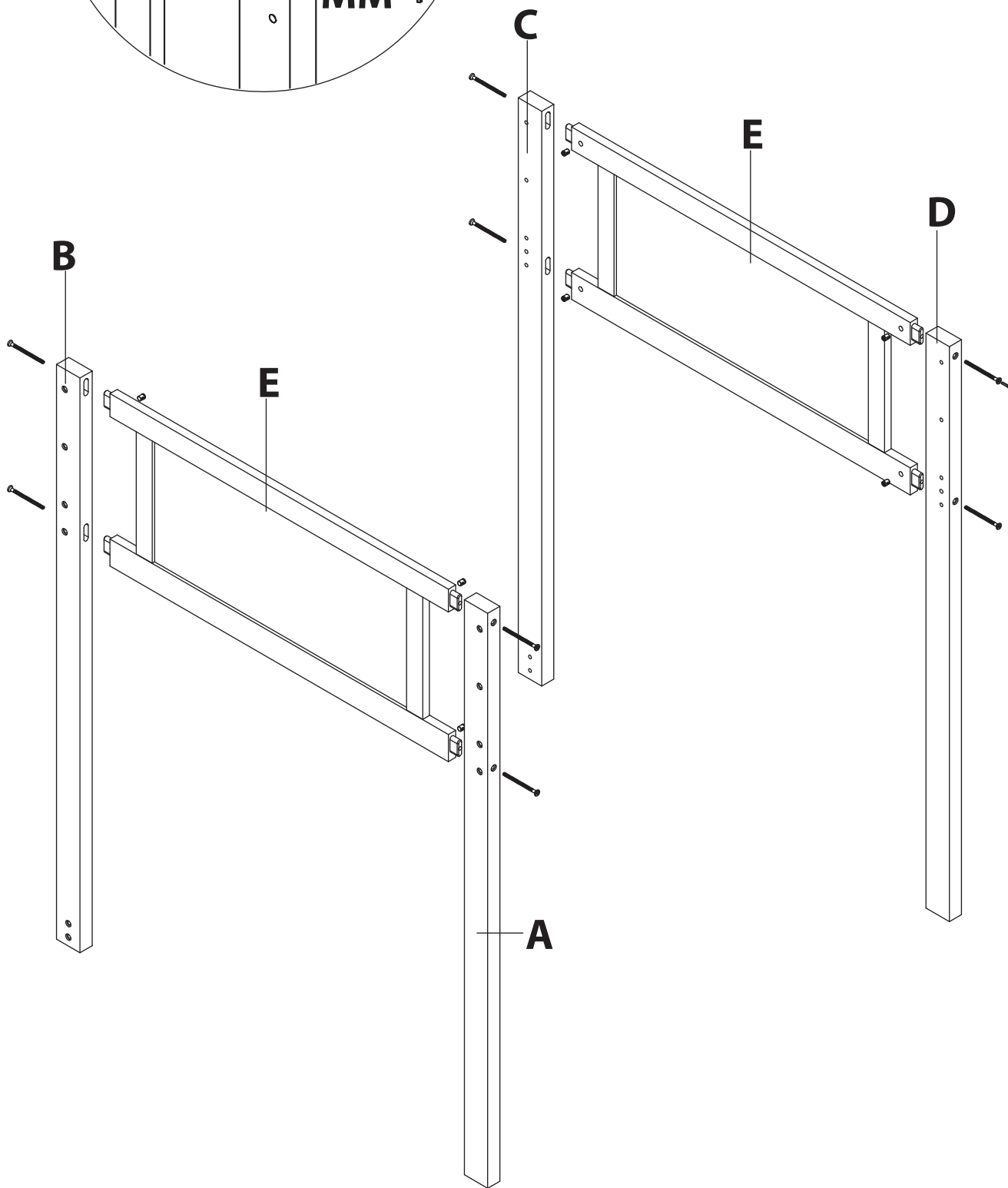



3

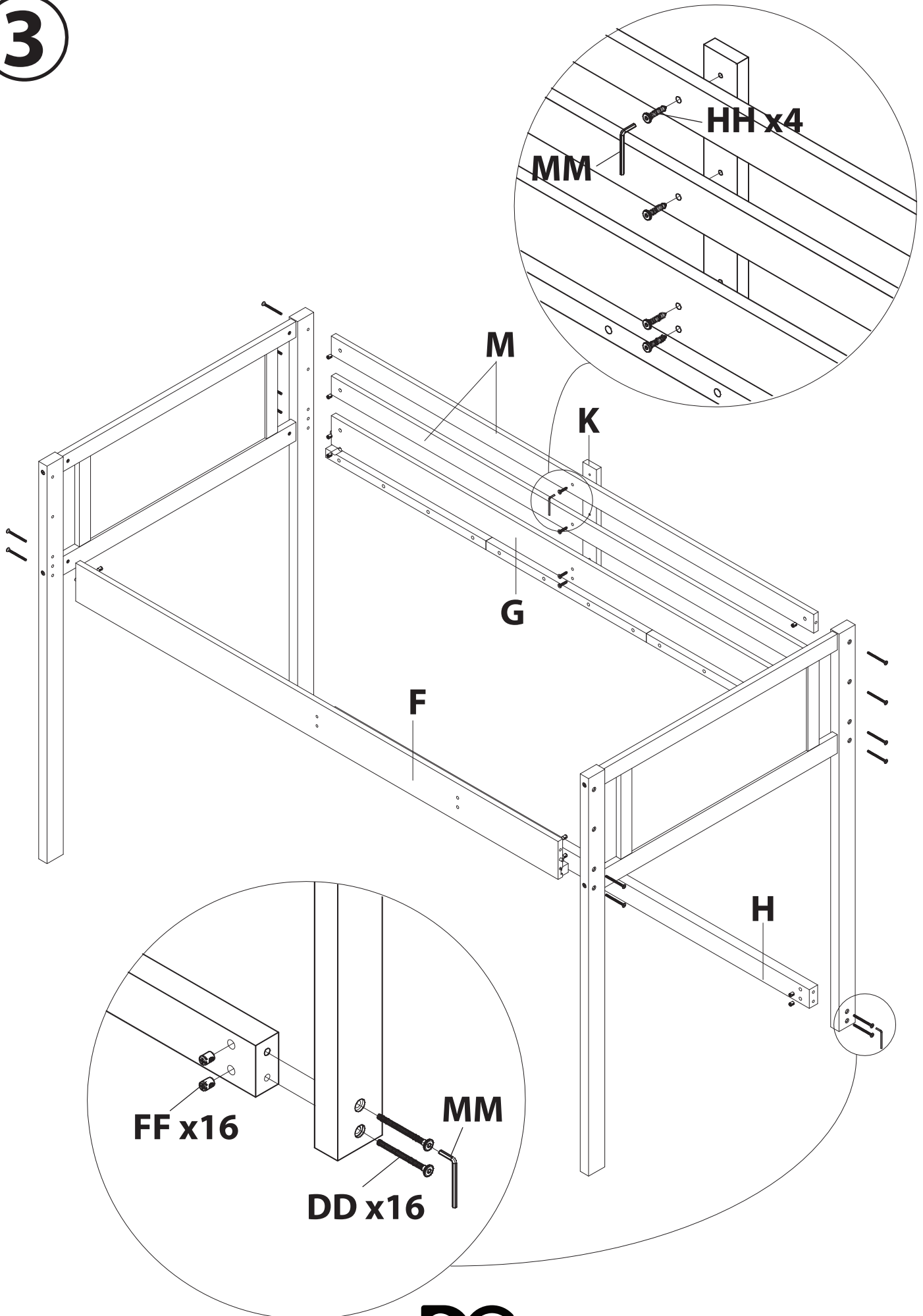



4

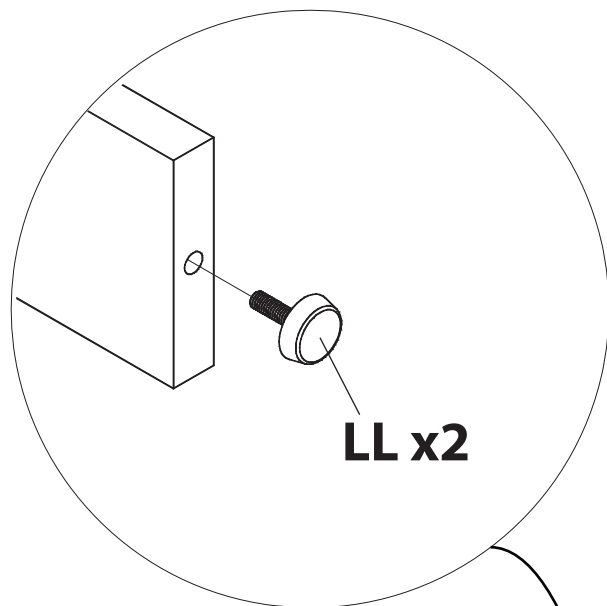

LL x2

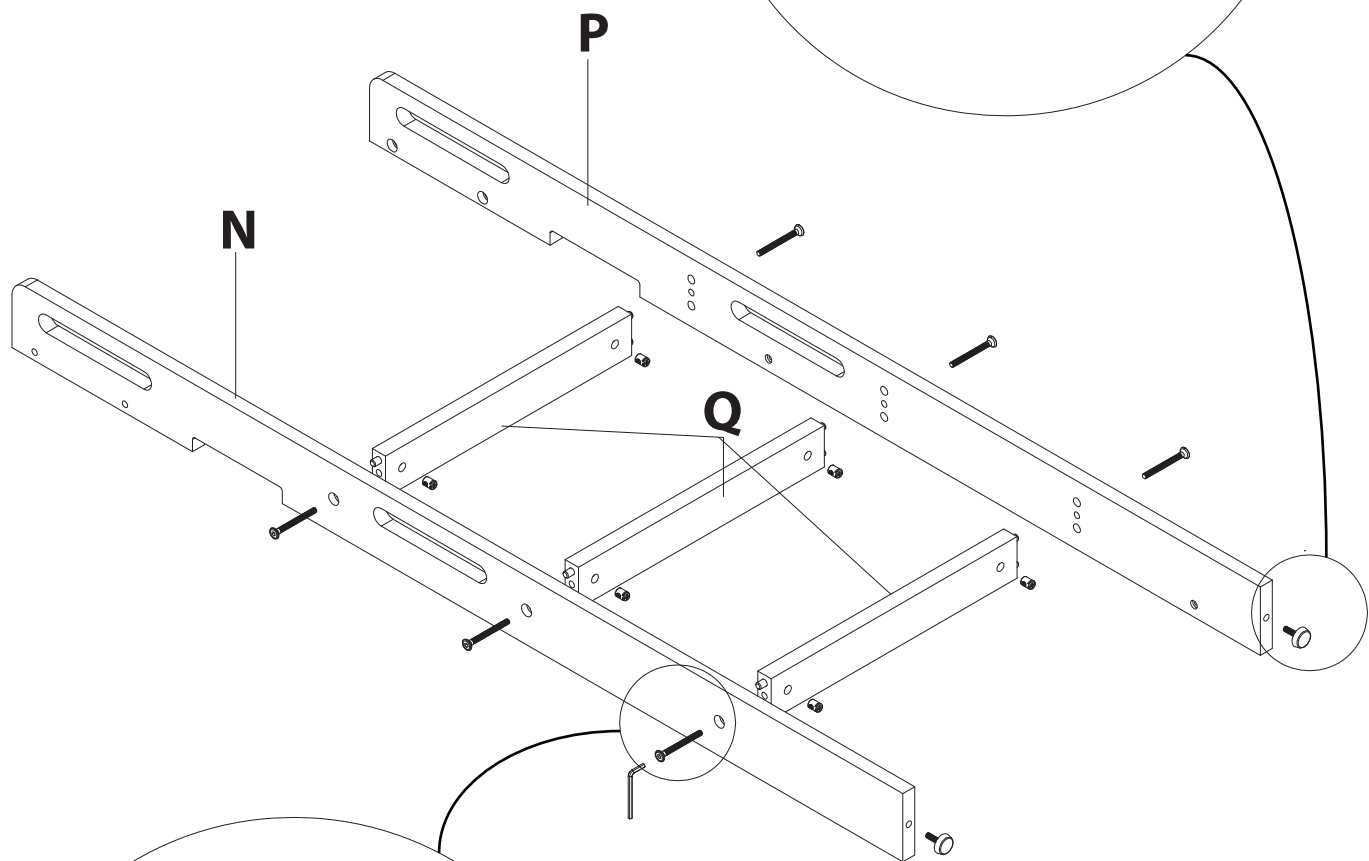

N

P

Q

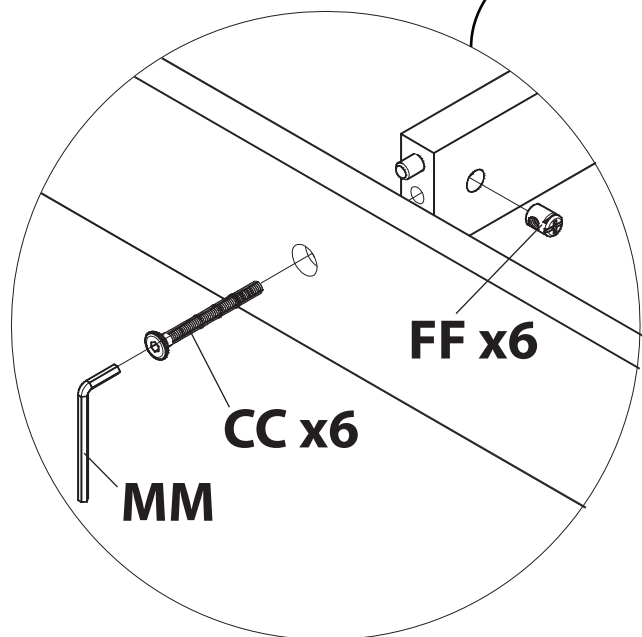

FF x6

CC x6

MM



5

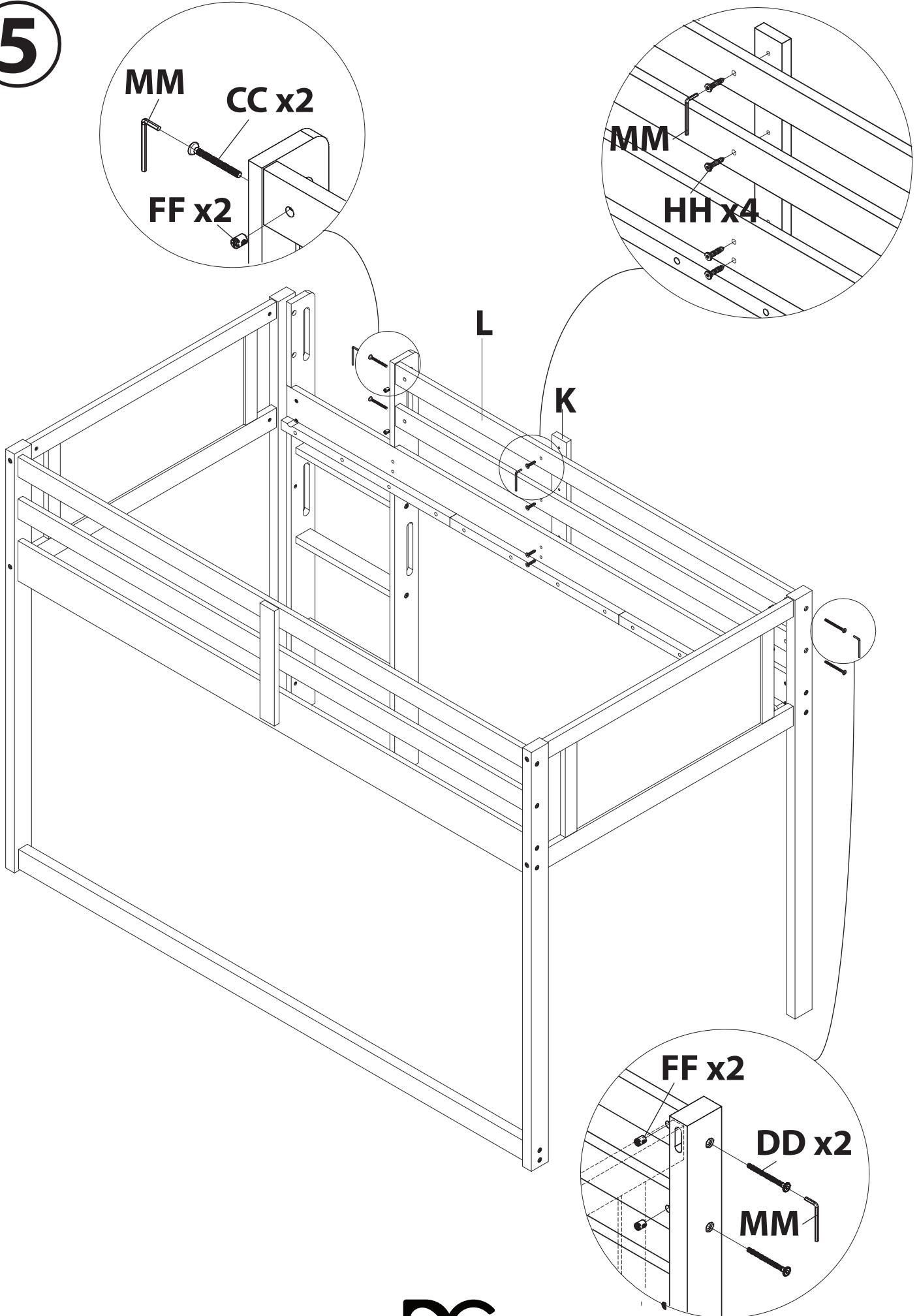



6

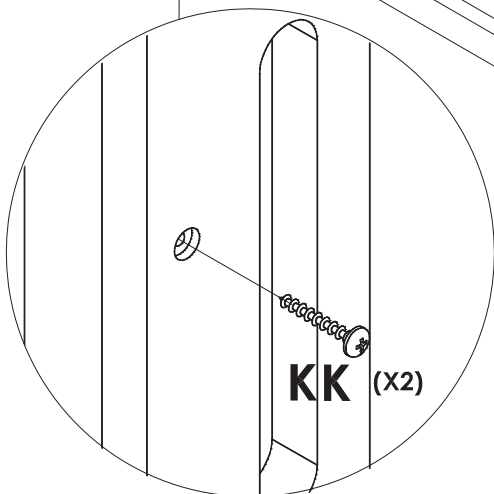
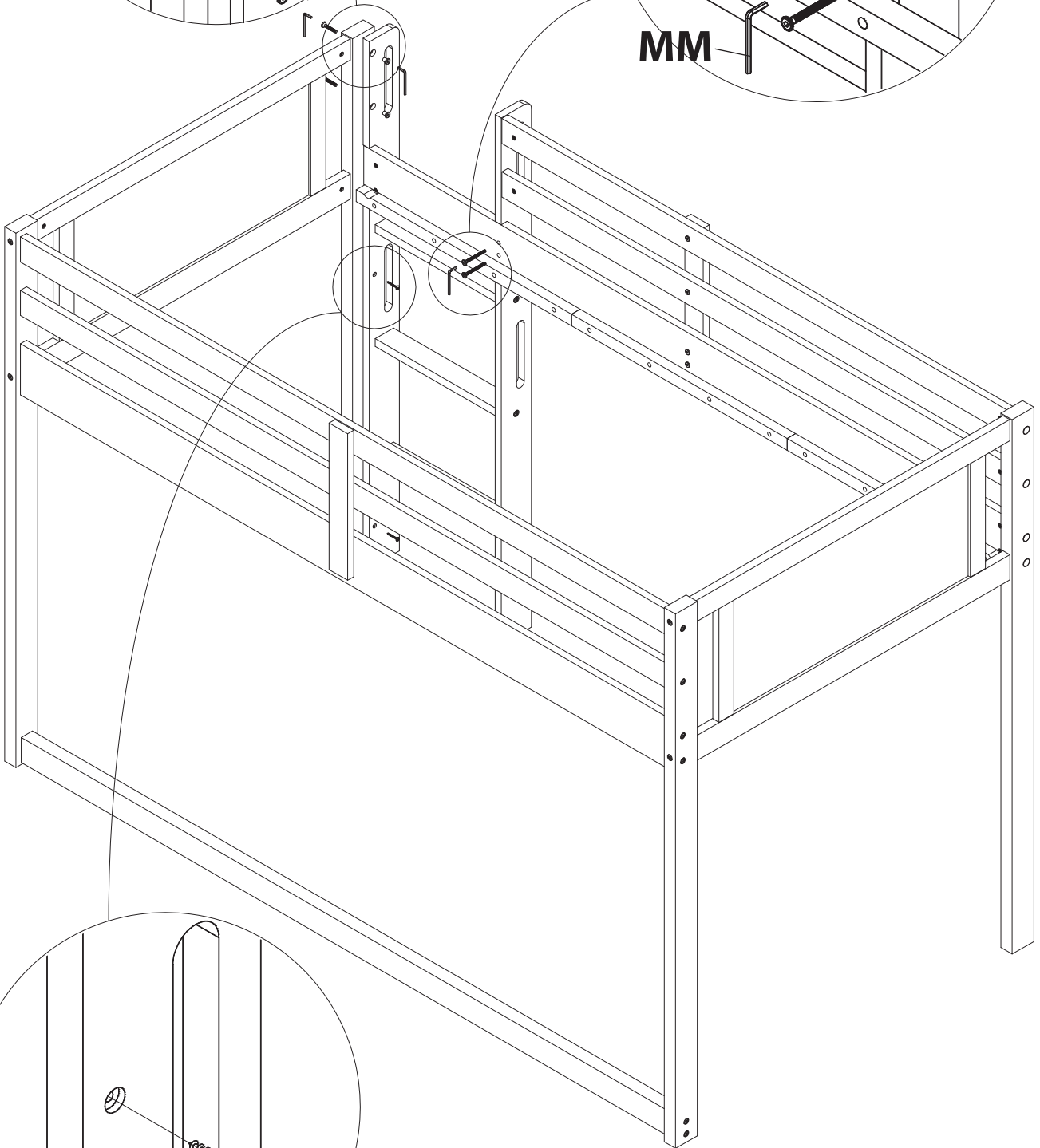
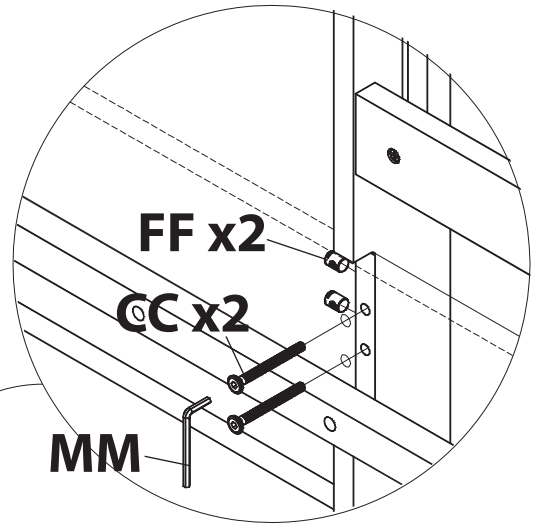
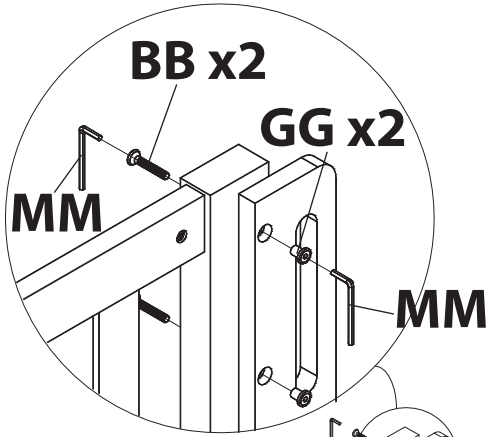



7

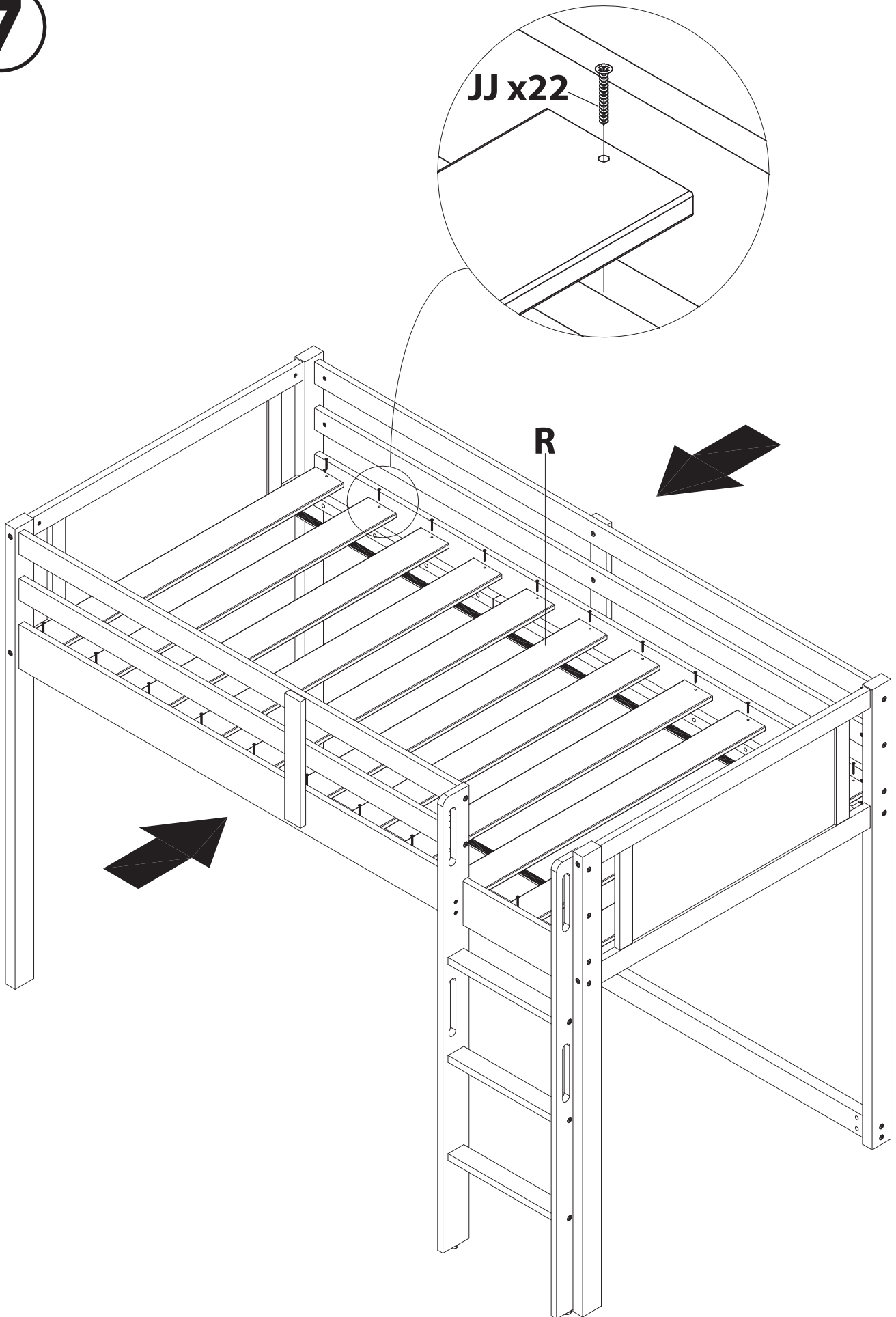

♥♥♥

WHY CHOOSE DELTA CHILDREN?

Visit Deltachildren.Com/Pages/Our-Story for more information

<p>DELTA LEADS</p> <p>1 Out Of 2 Children In The U.S. Sleep In Our Products</p>	<p>DELTA GIVES</p> <p>10% Of Our Proceeds Go Toward Improving The Lives Of Children</p>	<p>DELTA CARES</p> <p>We Test Above & Beyond Industry Safety Standards</p>	<p>DELTA IS DEDICATED</p> <p>Our Family-Run Company Has Been There For Your Family Since 1968</p>	<p>DELTA GROWS WITH YOU</p> <p>We Have Products For Every Age And Stage</p>	<p>Over 50 Years Of Safety, Style & Innovation</p>
--	--	---	--	--	---

Welcome to the **DELTA FAMILY**
Here's a Gift From Us To You







10% OFF

Your Next Purchase From
DeltaChildren.com

USE CODE:
DELTA10

*Exclusions Apply
*Subject to Change

PRODUCTS FOR EVERY AGE AND STAGE

					
CRIBS	STROLLERS	GLIDERS	BASSINETS	MATRESSES	
					
BABY GEAR	TODDLER BEDS	PLAYROOM FURNITURE	TWIN BEDS	BINS & ORGANIZERS	DRESSERS

OUR FAMILY OF TOP BRANDS



OVER 50 YEARS OF SAFETY, STYLE, AND INNOVATION



