

READ ALL INSTRUCTIONS BEFORE
ASSEMBLY AND USE.
KEEP INSTRUCTIONS FOR FUTURE USE.
⚠️ ADULT ASSEMBLY REQUIRED
DUE TO THE PRESENCE OF SMALL PARTS
DURING ASSEMBLY, KEEP OUT OF REACH OF
CHILDREN UNTIL ASSEMBLY IS COMPLETE.

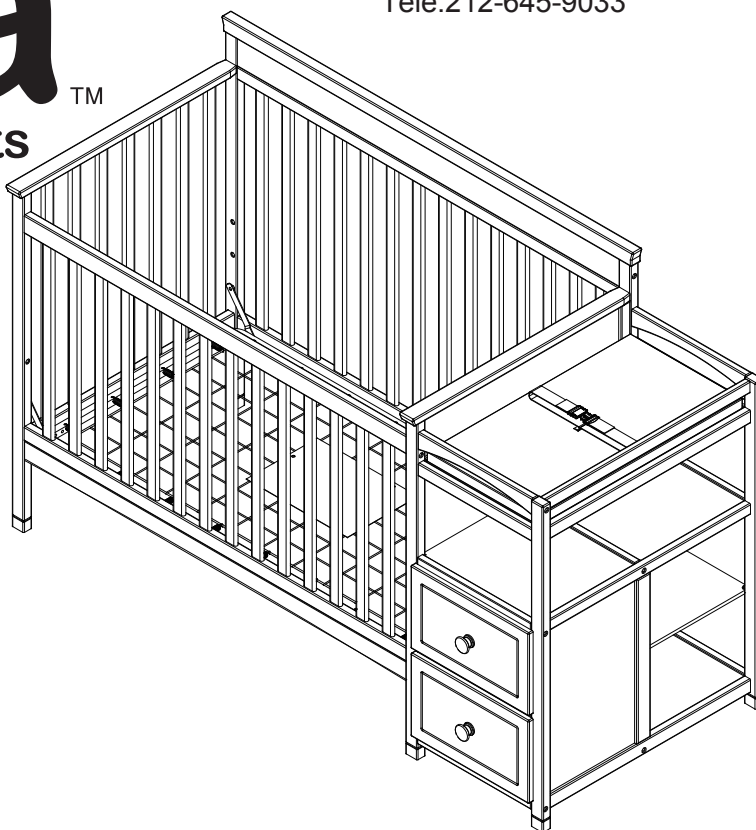

Consumer Care:
www.deltachildrensproducts.com
Delta Children's Products
114 West 26th Street
New York, NY 10001
Tele.212-645-9033

DeltaTM
Children's Products



STYLE No: 78001



COLOR



REV



FTY

THIS PRODUCT IS NOT INTENDED FOR INSTITUTIONAL OR COMMERCIAL USE.

If you have any questions or missing parts, contact us. DO NOT return product parts to the store from where it was purchased before contacting Delta Children's Products Customer Service. Make sure that all preassemble parts are tight. The appearance of your product may be different from that pictured in this booklet.

To register your product for important safety alerts and updates to your product please visit www.deltachildrensproducts.com

⚠CAUTION: ANY MATTRESS USED IN THIS CRIB MUST BE AT LEAST 27 1/4 INCHES BY 51 5/8 INCHES WITH A THICKNESS NOT EXCEEDING 6 INCHES.

⚠WARNING: CRIB

Infants can suffocate on soft bedding. Never add a pillow or comforter. Never place additional padding under an infant.

Failure to follow these warnings and the assembly instructions could result in serious injury or death.

To reduce the risk of SIDS, pediatricians recommend healthy infants be placed on their backs to sleep, unless otherwise advised by your physician.

ADULT ASSEMBLY REQUIRED DUE TO SMALL PARTS.

*Read all instructions before assembling crib. **KEEP INSTRUCTIONS FOR FUTURE USE.**

***Strangulation Hazard:** STRINGS CAN CAUSE STRANGULATION! **Do not** place items with a string around a child's neck, such as hood strings or pacifier cords. **Do not** suspend strings over a crib or attach strings to toys.

***Strangulation Hazard:** To help prevent strangulation tighten all fasteners. A child can trap parts of the body or clothing on loose fasteners.

***Strangulation Hazard:** **Do not** place crib near window where cords from blinds or drapes may strangle a child.

***Fall Hazard:** When child is able to pull to a standing position, set mattress to lowest position and remove bumper pads, large toys and other objects that could serve as steps for climbing out. This crib has an adjustable mattress support. For the convenience of the parent when the baby is very small, the mattress support may be used in the highest position. Important: with the mattress support and mattress in the highest position, be absolutely sure that the top of the front crib side is at least 3 inches higher than the top surface of the mattress. If it is not, lower the mattress support and the mattress to the next highest position.

***Fall Hazard:** Stop using crib when child begins to climb out or reaches a height of 35in. (90cm), whichever occurs first. The child should be placed in a youth or regular bed.

*Check this product for damaged hardware, loose joints, missing parts or sharp edges before and after assembly and frequently during use. **Do not use crib** if any parts are missing, damaged or broken. Contact Delta Children's Products for replacement parts and instructional literature if needed. Do not substitute parts.

*Follow warnings on **all** products in a crib.

***Do not** use a water mattress with this crib.

*If refinishing, use a non-toxic finish specified for children's products.

***Never** use plastic shipping bags or other plastic film as mattress covers because they can cause suffocation.

*Infants can suffocate in gaps between crib sides and a mattress that is too small.

*Ensure a safe environment for the child by checking regularly, before placing the child in the crib, that every component is properly and securely in place.

*To avoid head injury, do not allow any child to play underneath the crib.

***Never** add an accessory such as a bassinet or changing table that extends over the sleeping area.

TODDLER BED

WARNING ENTRAPMENT/STRANGULATION HAZARD

*INFANTS HAVE DIED IN **TODDLER BEDS** FROM ENTRAPMENT AND STRANGULATION. Failure to follow these warnings and the assembly instructions could result in serious injury or death.

***Never** use bed with children under 15 months.

***Never** place bed near windows where cords from blinds or drapes may strangle a child.

***Do not** place items with a string, cord, or ribbon around a child's neck, such as hood strings or pacifier cords.

***Do not** suspend strings over a toddler bed for any reason.

*The users maximum weight shall not be greater than 50 lb (22.7kg).

*The mattress intended for use on the bed shall be a full-size crib mattress having minimum dimensions of 51 5/8 in. (1310 mm) in length, 27 1/4 in. (690 mm) in width and 4 in. (100 mm) in thickness.

*Stabilizer bar(s) must be used when converted to a toddler bed.

WARNING: CHANGING TABLE

Fall hazard - to prevent death or serious injury, always keep child within arm's reach.

Read all instructions before use of the changing table.

KEEP THESE INSTRUCTIONS IN A SAFE PLACE FOR FUTURE USE.

Inspect the changing table periodically. **Do not** use the changing table if it is damaged or broken.

Contact Delta Children's Products with any questions.

Tighten all loose screws and bolts before each use.

The maximum recommended weight of the child is 30lbs for the changing table.

Use only the pad provided by Delta Children's Products.

Always secure the pad to the changing surface by inserting the strap through the hole in the middle of the pad. See Instructions.

NOTES ON ASSEMBLY:

-During the assembly process whenever using screws or bolts, check each by placing the screw/bolt on the diagram of the item which is drawn actual size and design. Be sure to use the proper size and shape specified in the instructions.

-To assemble this unit you may be required to place the unit on it's side and face. It is strongly recommended that assembly is done on a soft, non-abrasive surface to avoid damaging the finish.

NOTES ON USE:

Keep children and others safe by following these simple rules:

- **Do not** allow any child to play on furniture

- **Do not** allow climbing on any piece of furniture.

- **Do not** allow hanging from any piece of furniture.

- Always monitor your child's activity when in the nursery.

NOTES ON CARE AND MAINTENANCE:

- **Do not** scratch or chip the finish.

- Inspect the product periodically, contact delta children's products for replacement parts or questions.

- **Do not** store the product or any parts in extreme temperatures and conditions such as a hot attic or a damp, cold basement. These extremes can cause a loss of structural integrity.

-To preserve the luster of the high quality finish on your product, it is recommended to place a doily or felt pad under any items you place on the finish.

-Clean with a damp cloth, then a dry cloth to preserve the original luster and beauty of this fine finish.

-**Do not** use abrasive chemicals.

-**Do not** spray cleaners directly onto furniture.

-Lift slightly when moving on carpeting to prevent leg breakage.

-Use of a vaporizer near furniture will cause wood to swell and finish to peel.

PARTS: MAKE SURE THAT ALL PRE-ASSEMBLED PARTS ARE TIGHT.

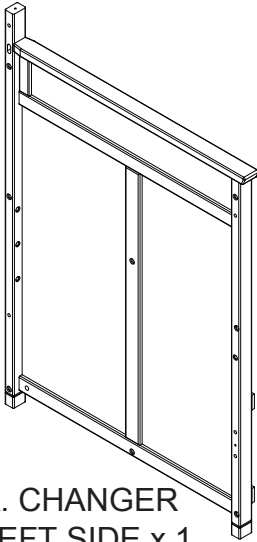

A. CHANGER LEFT SIDE x 1
PART # 21517

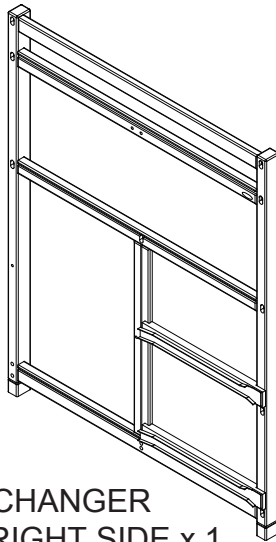

B. CHANGER RIGHT SIDE x 1
PART # 21519

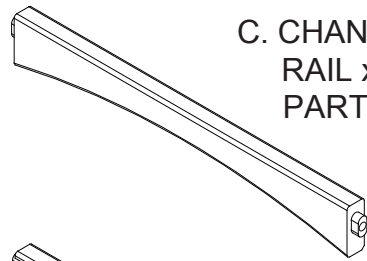

C. CHANGER TOP RAIL x 2
PART # 21520



D. CHANGER UPPER SHELF RAIL x 2
PART # 21521

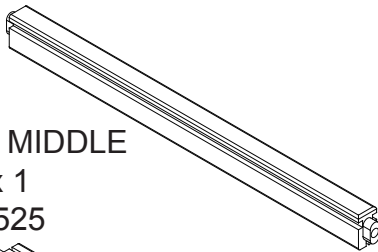
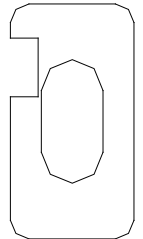

H. CHANGER MIDDLE TOP RAIL x 1
PART # 21525

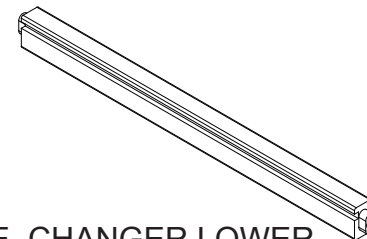

E. CHANGER LOWER SHELF RAIL x 2
PART # 21522

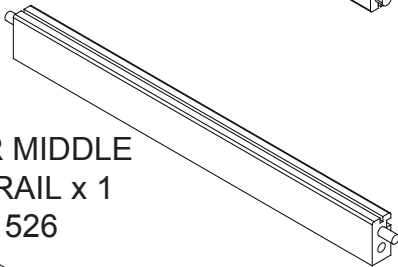

J. CHANGER MIDDLE BOTTOM RAIL x 1
PART # 21526

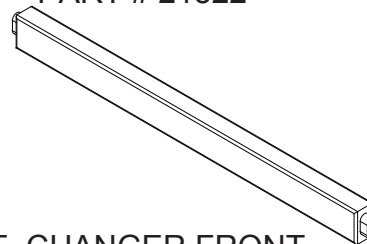
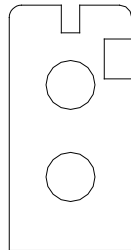

F. CHANGER FRONT LOWER RAIL x 1
PART # 21523

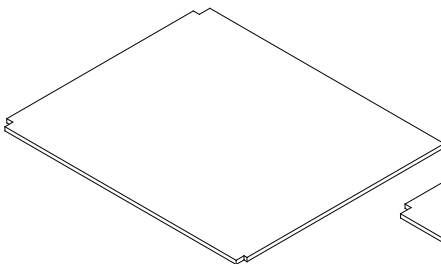
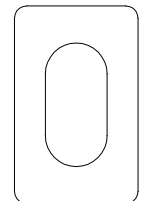

L. CHANGER MIDDLE FRONT SHELF x 1
PART # 21530

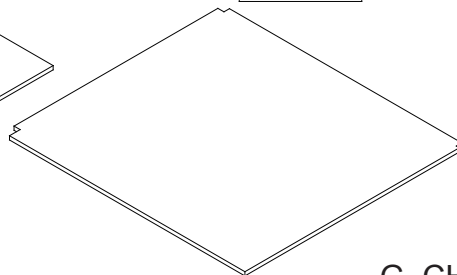

M. CHANGER MIDDLE BACK SHELF x 1
PART # 21531

G. CHANGER FRONT BOTTOM RAIL x 1
PART # 21524

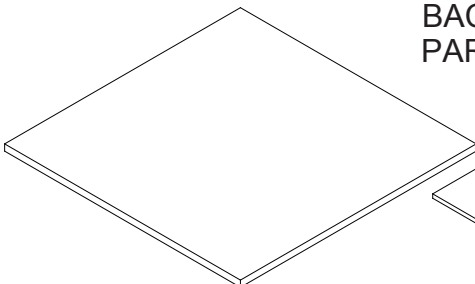
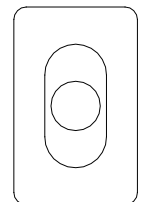
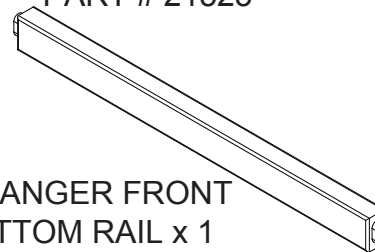

P. CHANGER REMOVABLE SHELF x 1
PART # 21534

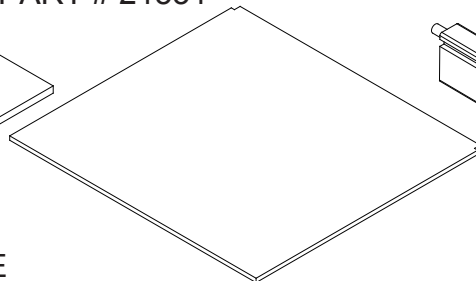

N. CHANGER BOTTOM SHELF x 1
PART # 21532

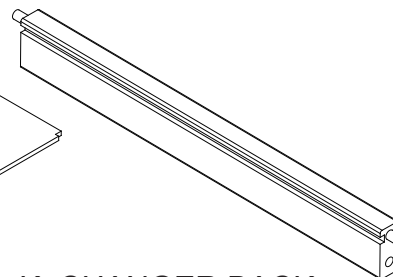

K. CHANGER BACK BOTTOM RAIL x 1
PART # 21527

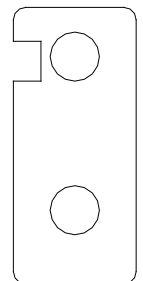

PARTS: MAKE SURE THAT ALL PRE-ASSEMBLED PARTS ARE TIGHT.

T. CHANGER MIDDLE
PANEL x 1
PART # 21533

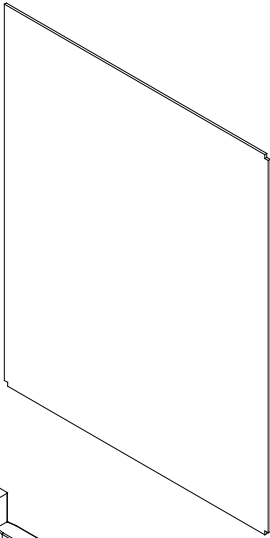

R. CHANGER SURFACE
WITH STRAP x 1
PART # 21528

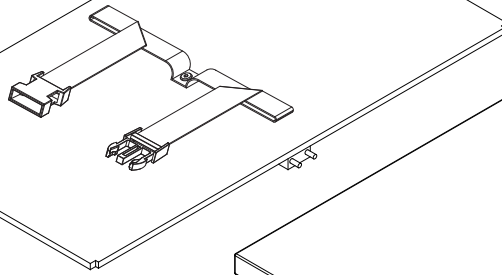

S. CHANGER PAD x 1
PART # 21529

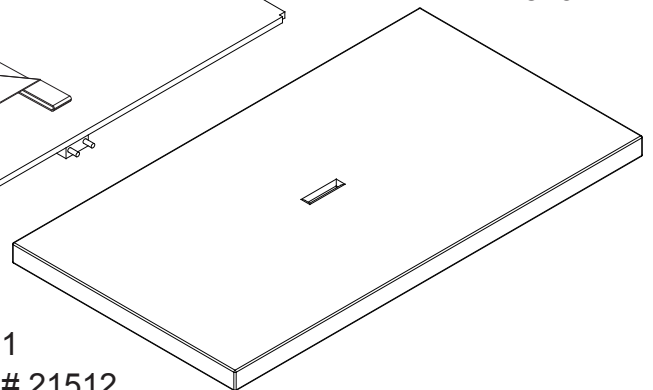

U. CRIB BACK
RAIL TOP x 1
PART # 21512



W. CRIB FRONT
RAIL x 1
PART # 21513

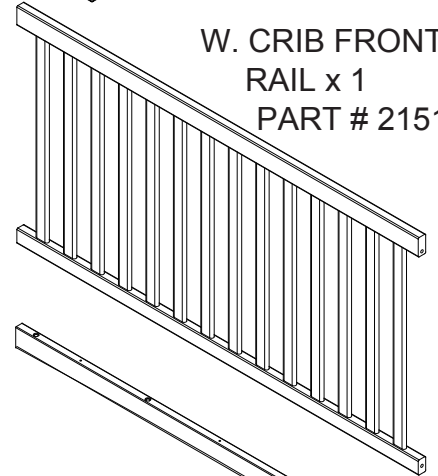

V. CRIB BACK RAIL x 1
PART # 21511

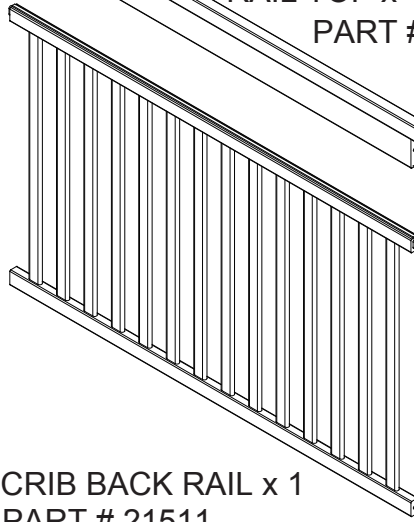

X. STABILIZER BAR x 1
PART # 21514

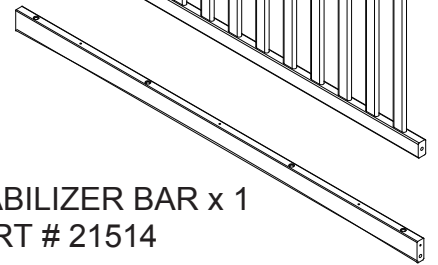

Y. CRIB LEFT END x 1
PART # 21515

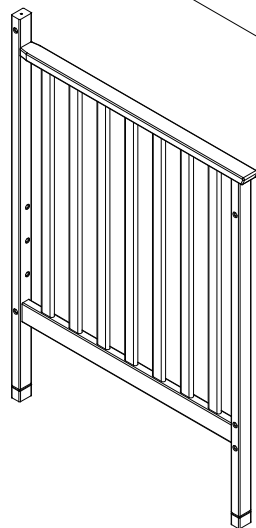

CC. DRAWER RIGHT SIDE
PANEL x 2
PART # 21538

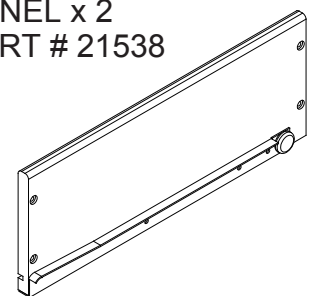
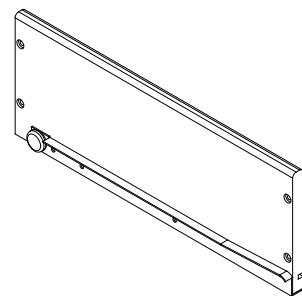

BB. DRAWER LEFT SIDE
PANEL x 2
PART # 21537

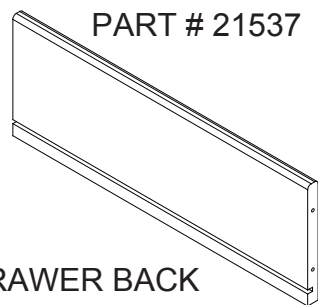

Z. DRAWER FRONT
PANEL x 2
PART # 21535

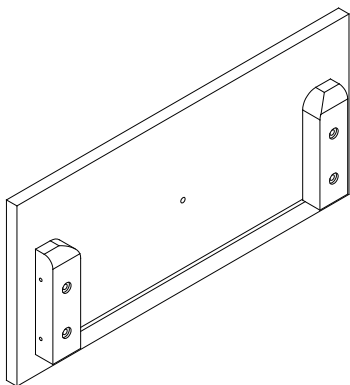

AA. DRAWER BACK
PANEL x 2
PART # 21536

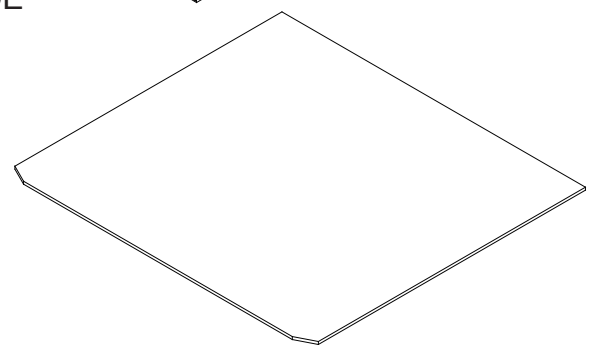

DD. DRAWER BOTTOM PANEL x 2
PART # 21539

PARTS: HARDWARE KIT IS PART # 21543 FOR COLOR 607 OR # 21544 FOR COLOR 209.
SEE FRONT COVER.

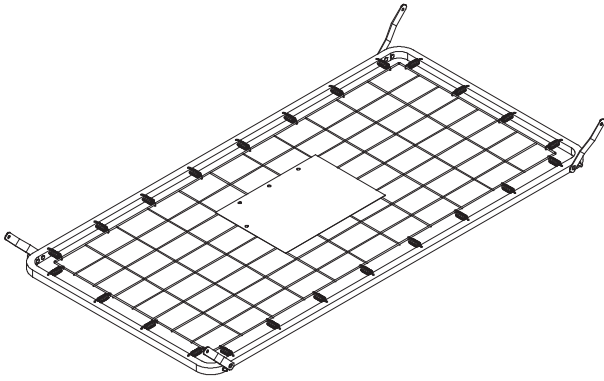



EE. MATTRESS SUPPORT x 1
PART # 21149

POUCH ATTACHED TO MATTRESS SUPPORT
- KEEP INSTRUCTIONS IN THIS POUCH
AFTER ASSEMBLY.
WARNINGS RELATED TO THE SAFE USE OF
THIS CRIB ARE PRINTED ON THE POUCH.

 No drills necessary.
Do not use power
screwdriver.

REQUIRED TOOLS

PHILLIPS SCREWDRIVER
NOT SUPPLIED



FLAT HEAD SCREWDRIVER
NOT SUPPLIED



MM. 25 mm SCREW x 8

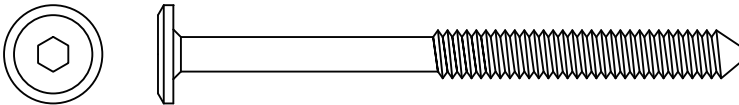

NN. 40 mm SCREW x 8



FF. M6 x75 mm BOLT x 8

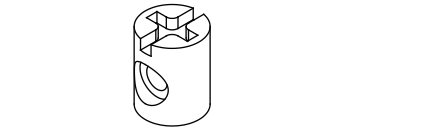

PP. PLASTIC BARREL NUT x 8

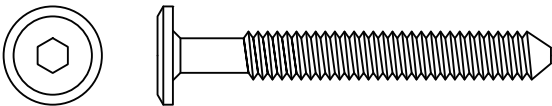

GG. M6 x50 mm BOLT x 14

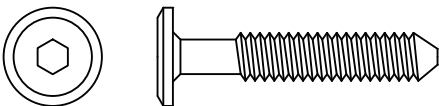

HH. M6 x35 mm BOLT x 4

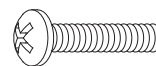

RR. HANDLE BOLT x 2

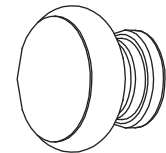

SS. HANDLE x 2
PART # 21541

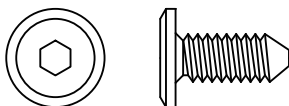

JJ. M6 x15 mm BOLT x 4



TT. SHELF CLIPS x 4



KK. Φ4x30 mm METAL PIN x 7

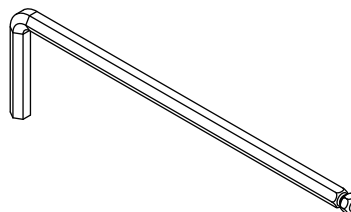

**M4 ALLEN WRENCH
SUPPLIED**

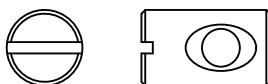

LL. BARREL NUT x 8

SECTION 1: CHANGING TABLE ASSEMBLY

STEP 1

PARTS AND TOOLS REQUIRED TO COMPLETE STEP

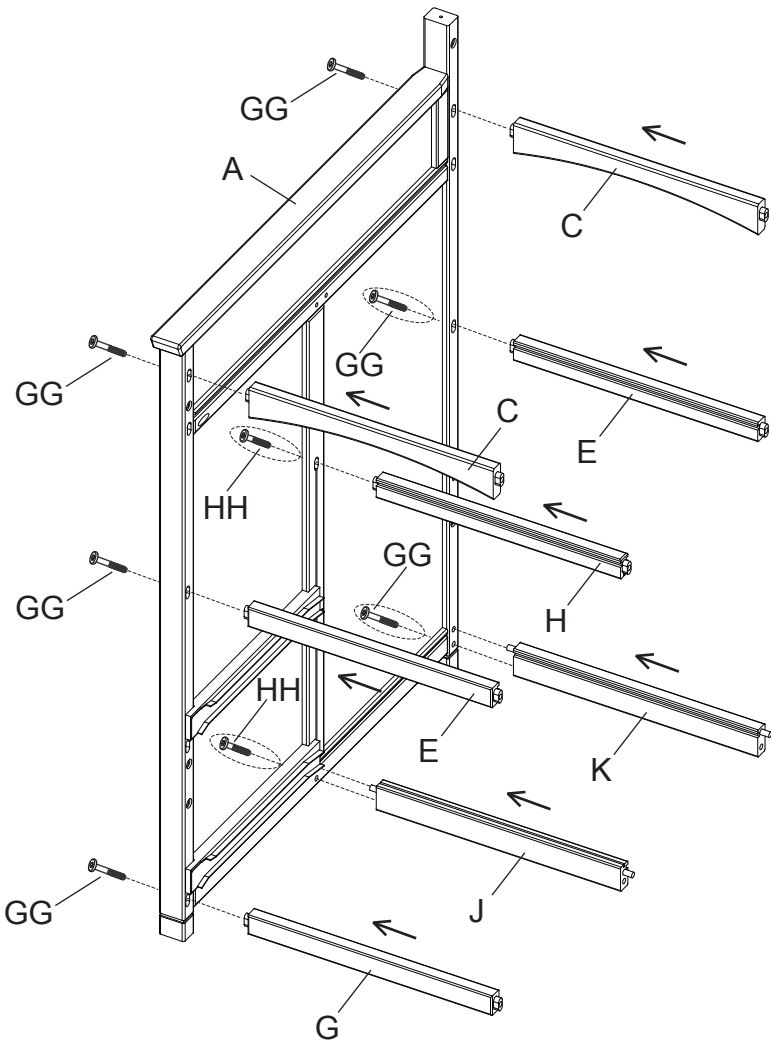
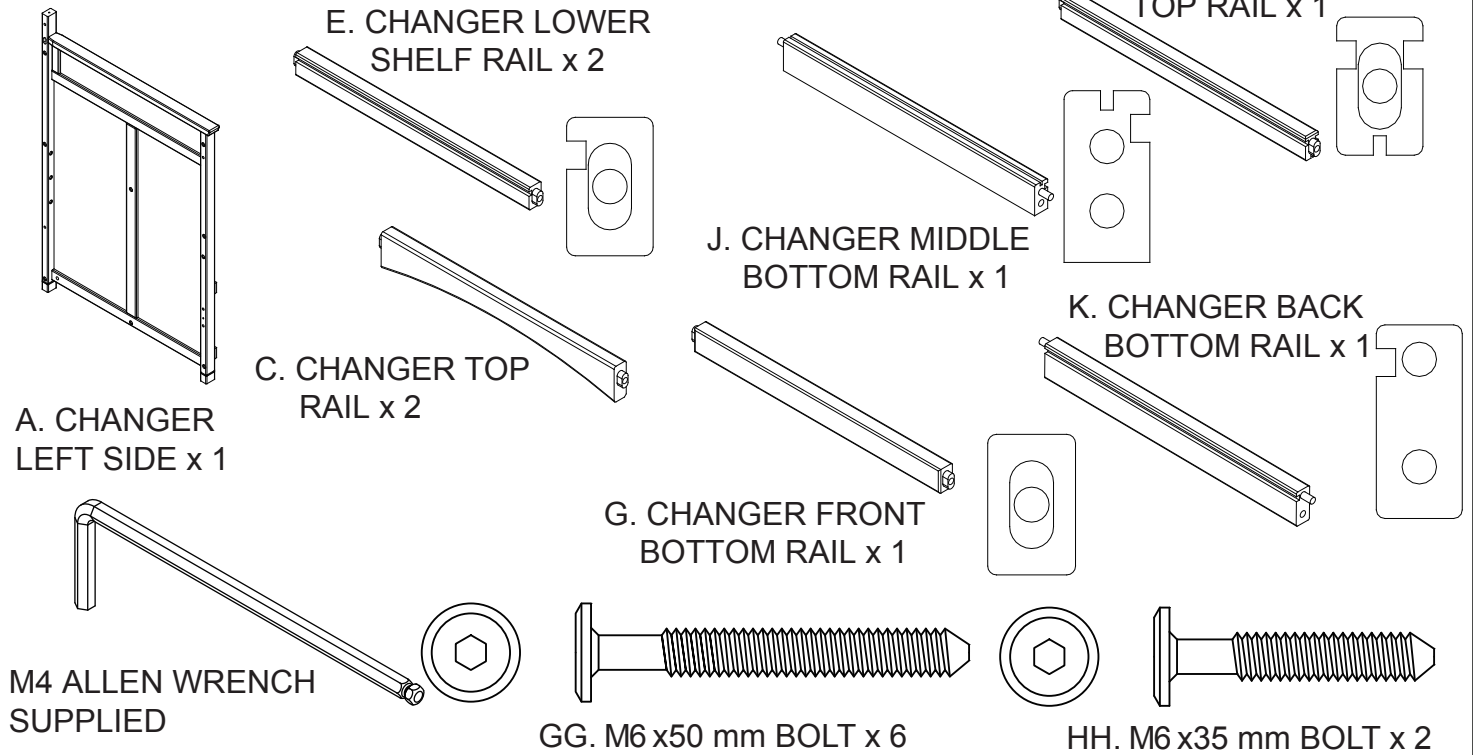

ATTACH (2) CHANGER TOP RAILS (PART C), (2) CHANGER LOWER SHELF RAILS (PART E), (1) CHANGER FRONT BOTTOM RAIL (PART G), (1) CHANGER MIDDLE TOP RAIL (PART H), (1) CHANGER MIDDLE BOTTOM RAIL (PART J) AND (1) CHANGER BACK BOTTOM RAIL (PART K) TO THE CHANGER LEFT SIDE (PART A) USING (6) M6 x 50 mm BOLT (PART GG) AND (2) M6 x 35 mm BOLT (PART HH). TIGHTEN WITH THE M4 ALLEN WRENCH.

SECTION 1: CHANGING TABLE ASSEMBLY

STEP 2

PARTS AND TOOLS REQUIRED TO COMPLETE STEP

FROM STEP 1

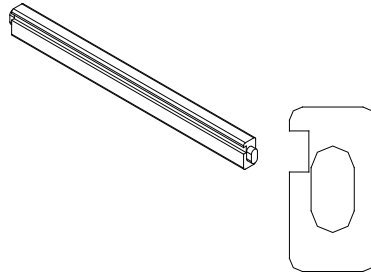
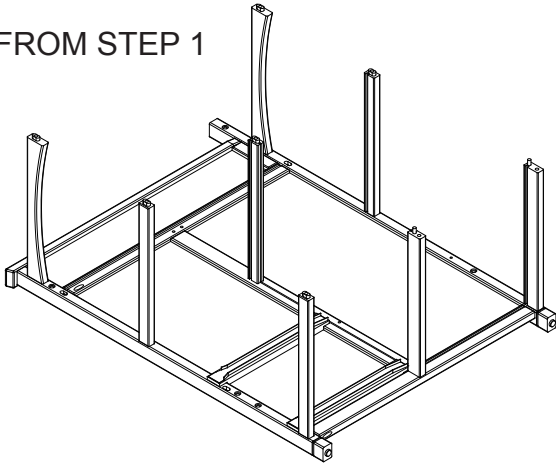

D. CHANGER UPPER SHELF RAIL x 2

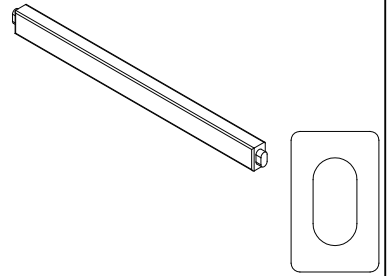

F. CHANGER FRONT LOWER RAIL x 1

LAY CHANGER LEFT SIDE (PART A) ON IT'S SIDE AND LOOSELY INSERT (2) CHANGER UPPER SHELF RAILS (PART D) AND (1) CHANGER FRONT LOWER RAIL (PART F) AS SHOWN.

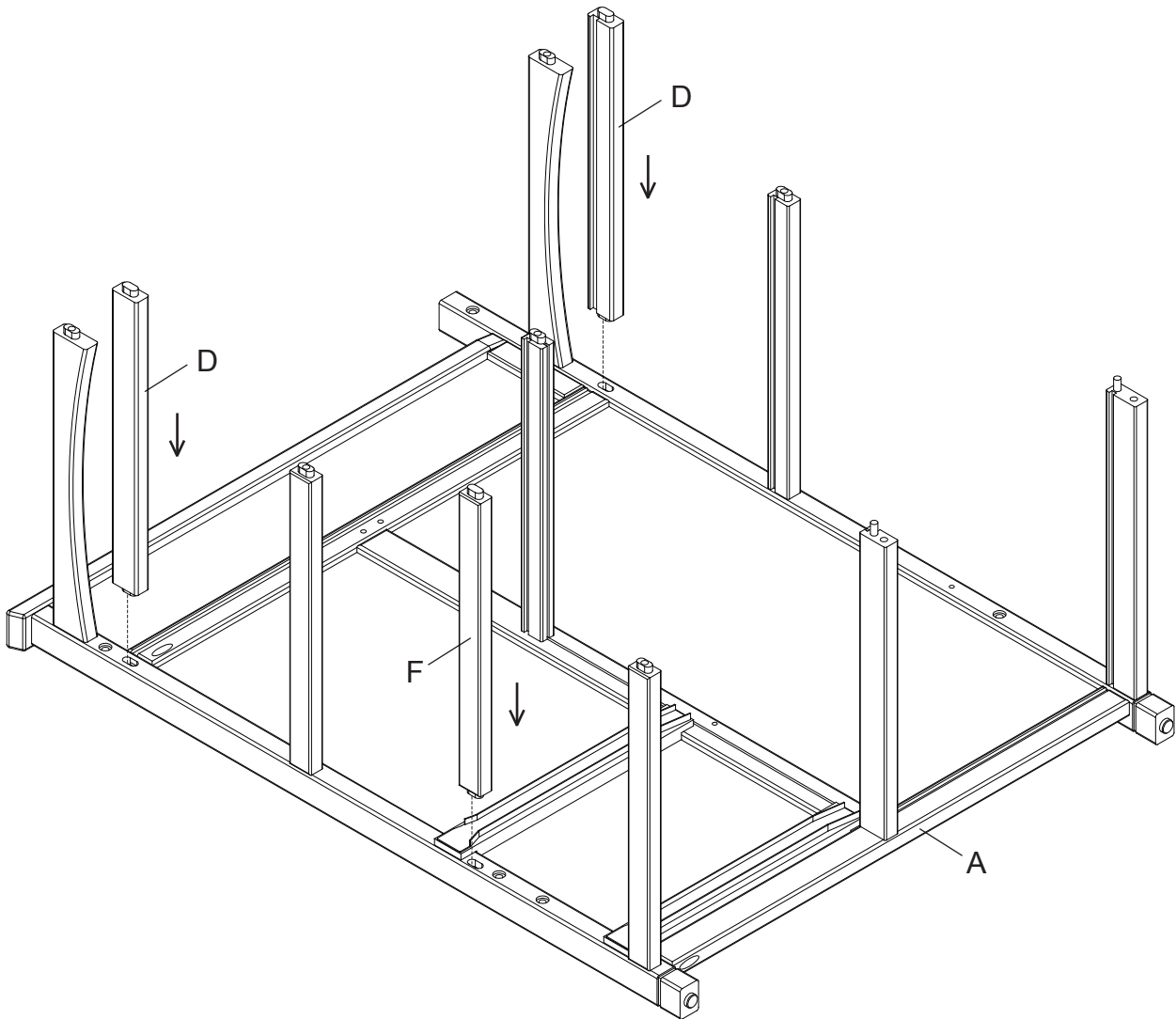

SECTION 1: CHANGING TABLE ASSEMBLY

STEP 3

PARTS AND TOOLS REQUIRED TO COMPLETE STEP

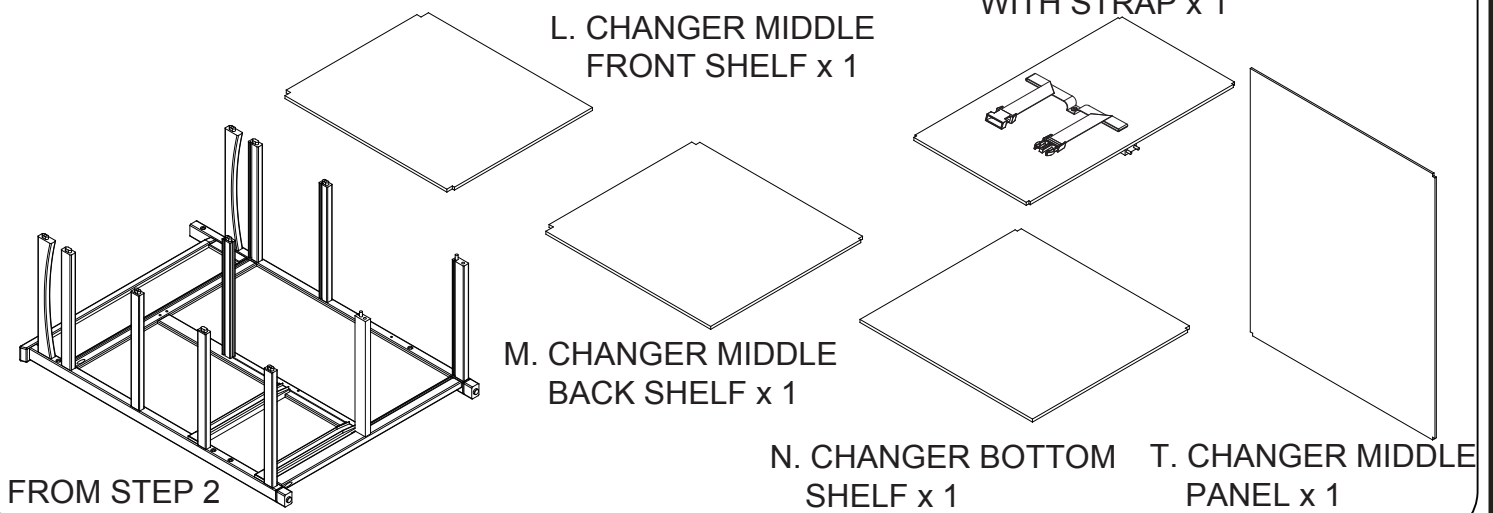

SLIDE CHANGER SURFACE WITH STRAP (PART R) IN BETWEEN CHANGER UPPER SHELF RAILS (PART D) GROOVES AS SHOWN.

SLIDE CHANGER MIDDLE FRONT SHELF (PART L) INTO CHANGER LOWER SHELF RAIL (PART E) AND CHANGER MIDDLE TOP RAIL (PART H) GROOVES AS SHOWN.

SLIDE CHANGER MIDDLE BACK SHELF (PART M) INTO CHANGER MIDDLE TOP RAIL (PART H) AND CHANGER LOWER SHELF RAIL (PART E) GROOVES AS SHOWN.

SLIDE CHANGER MIDDLE PANEL (PART T) INTO CHANGER MIDDLE TOP RAIL (PART H) AND CHANGER MIDDLE BOTTOM RAIL (PART J) GROOVES AS SHOWN.

SLIDE CHANGER BOTTOM SHELF (PART N) INTO CHANGER BACK BOTTOM RAIL (PART K) AND CHANGER MIDDLE BOTTOM RAIL (PART J) GROOVES AS SHOWN.

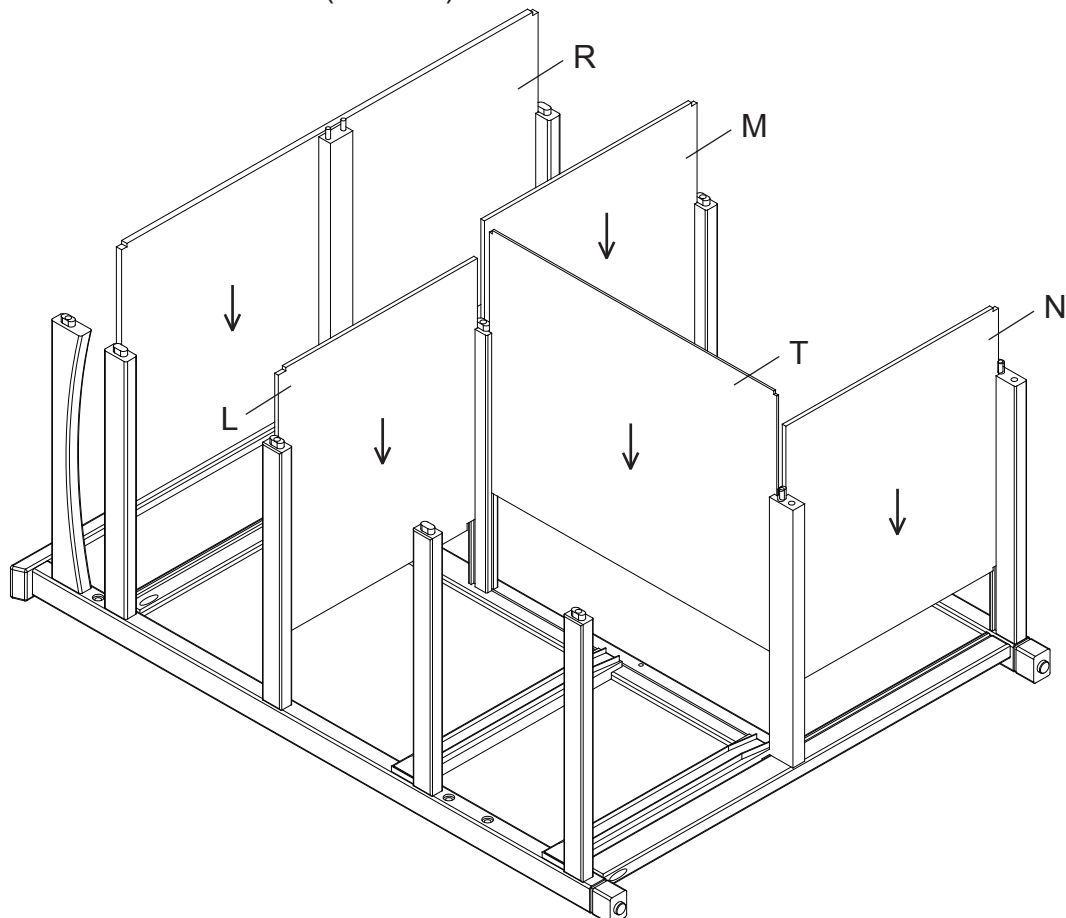

SECTION 1: CHANGING TABLE ASSEMBLY

STEP 4

PARTS AND TOOLS REQUIRED TO COMPLETE STEP

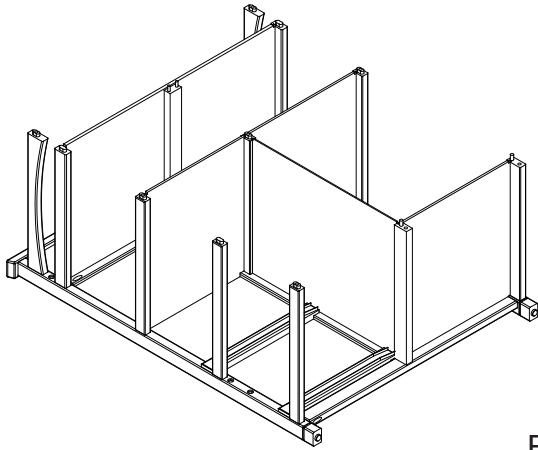

FROM STEP 3

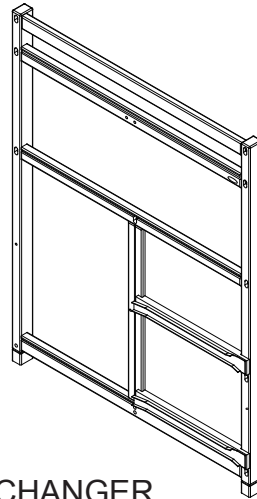

B. CHANGER
RIGHT SIDE x 1

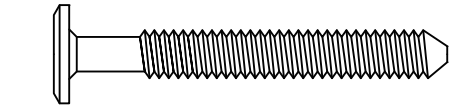
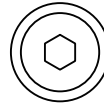

GG. M6 x50 mm BOLT x 6

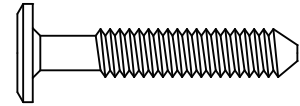
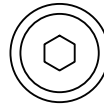

HH. M6 x35 mm BOLT x 2



M4 ALLEN WRENCH
SUPPLIED

CAREFULLY ALIGN ALL PANELS, TABS AND PINS WITH THE HOLES AND SLOTS IN THE CHANGER RIGHT SIDE (PART B). INSERT (6) M6x50mm BOLTS (PART GG) AND (2) M6x35mm BOLTS (PART HH) AS SHOWN. TIGHTEN ALL BOLTS WITH THE M4 ALLEN WRENCH.

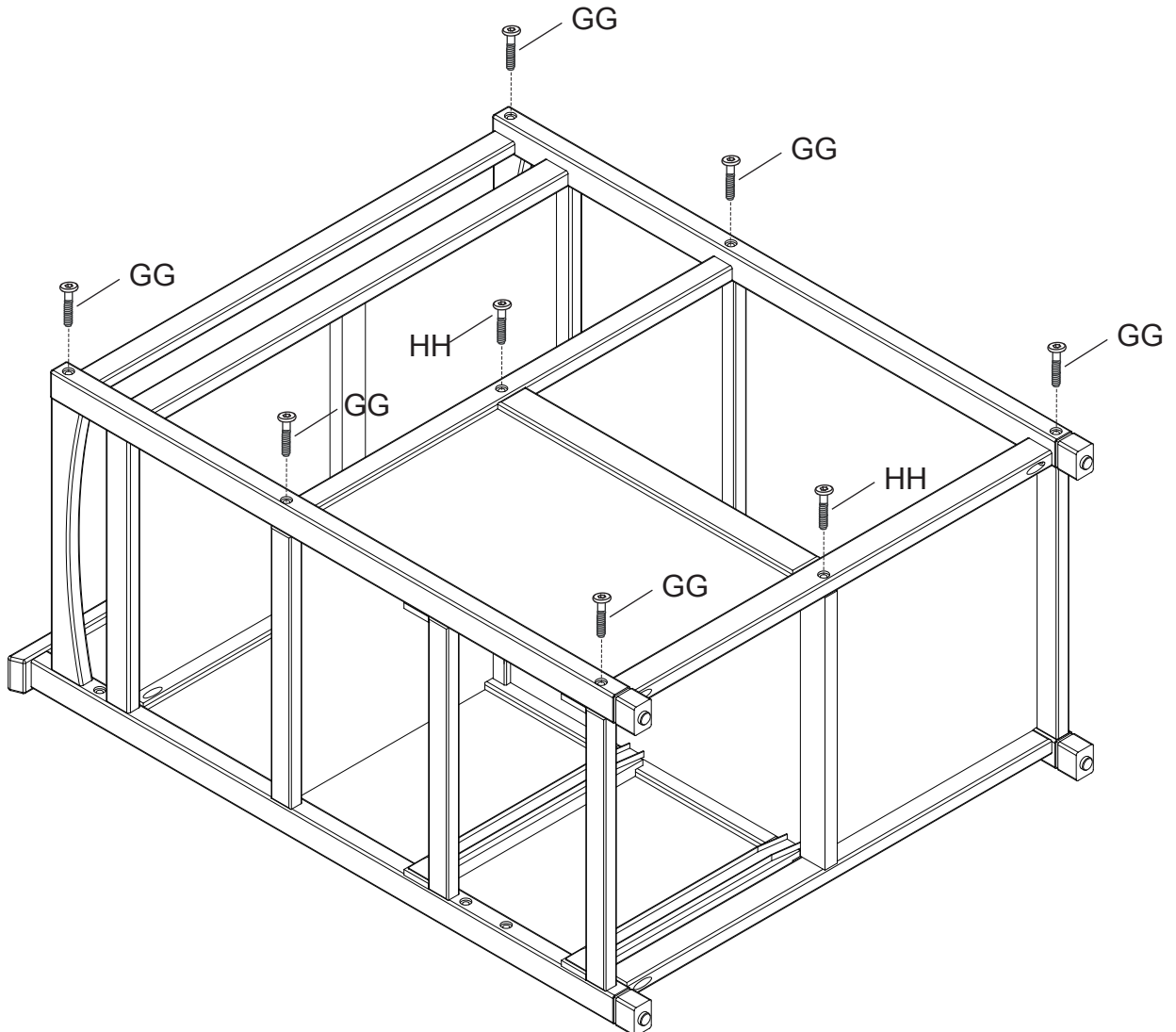

SECTION 2: CRIB ASSEMBLY

STEP 1

PARTS AND TOOLS REQUIRED TO COMPLETE STEP

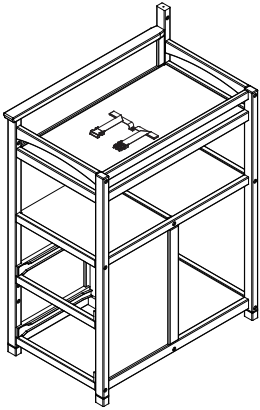

FROM SECTION 1
STEP 4

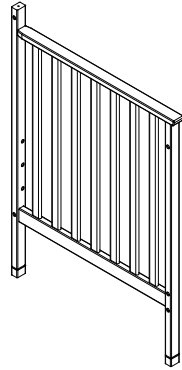

Y. CRIB LEFT END x 1

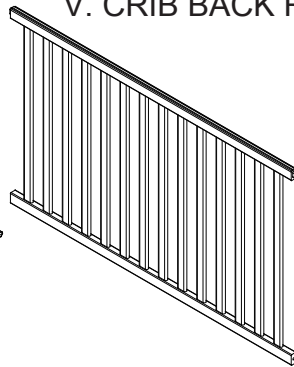

V. CRIB BACK RAIL x 1



M4 ALLEN WRENCH
SUPPLIED

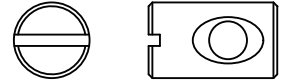

LL. BARREL NUT x 2

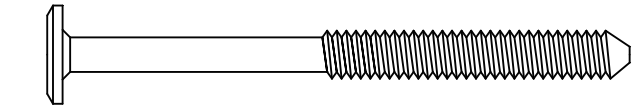
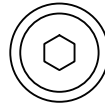

FF. M6x75 mm BOLT x 2

ATTACH (1) CRIB BACK RAIL (PART V) AND (1) CRIB LEFT END (PART Y) TO THE ASSEMBLY FROM SECTION 1 STEP 4 USING (2) M6x75 mm BOLTS (PART FF) AND (2) BARREL NUTS (PART LL). TIGHTEN WITH THE M4 ALLEN WRENCH. USE THE FLAT HEAD SCREWDRIVER TO HOLD THE BARREL NUT IN THE PROPER ALIGNMENT. DO NOT TIGHTEN THE BOLTS INSTALLED IN THE PERVIOUS STEP.

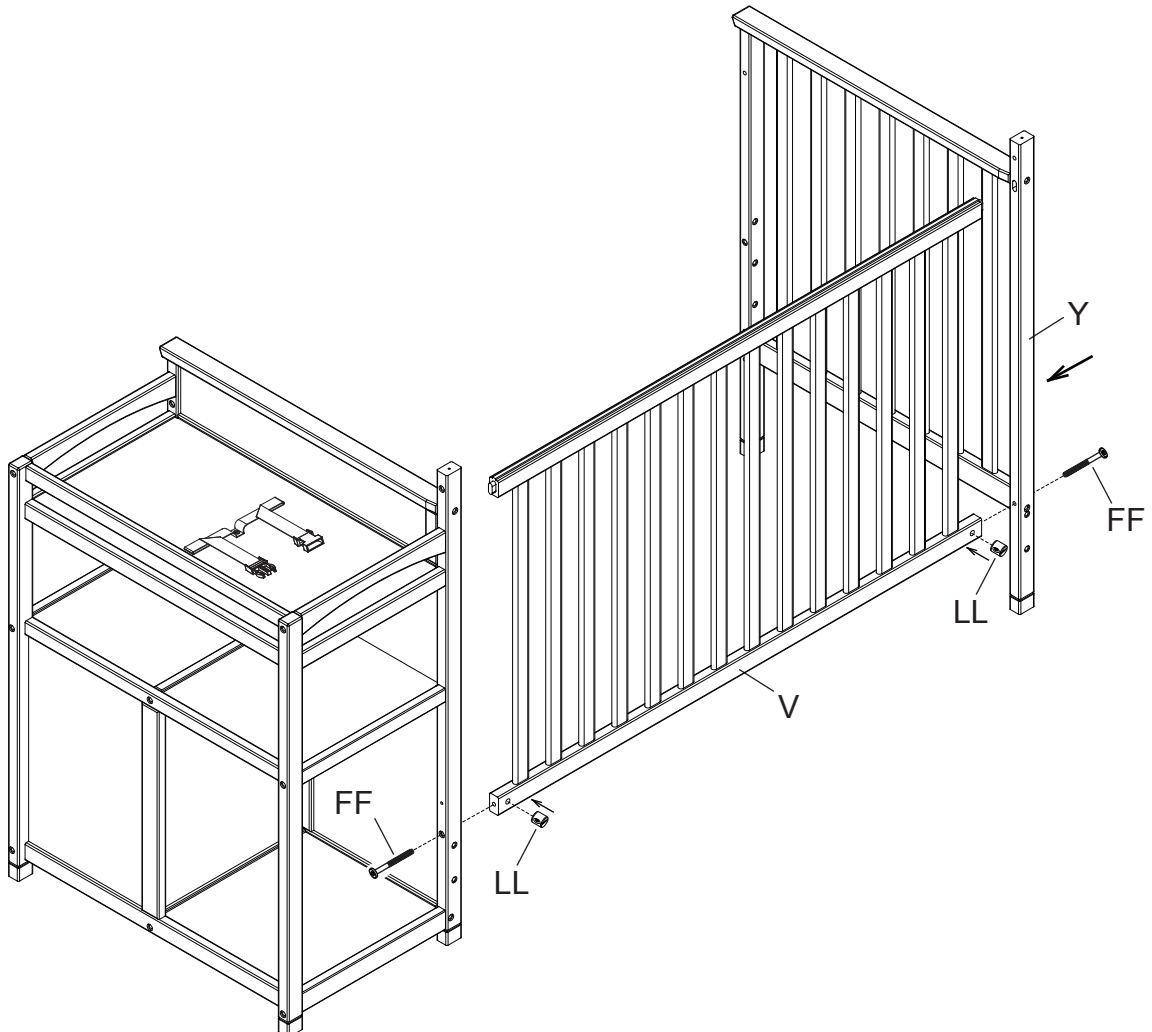

SECTION 2: CRIB ASSEMBLY

STEP 2

PARTS AND TOOLS REQUIRED TO COMPLETE STEP

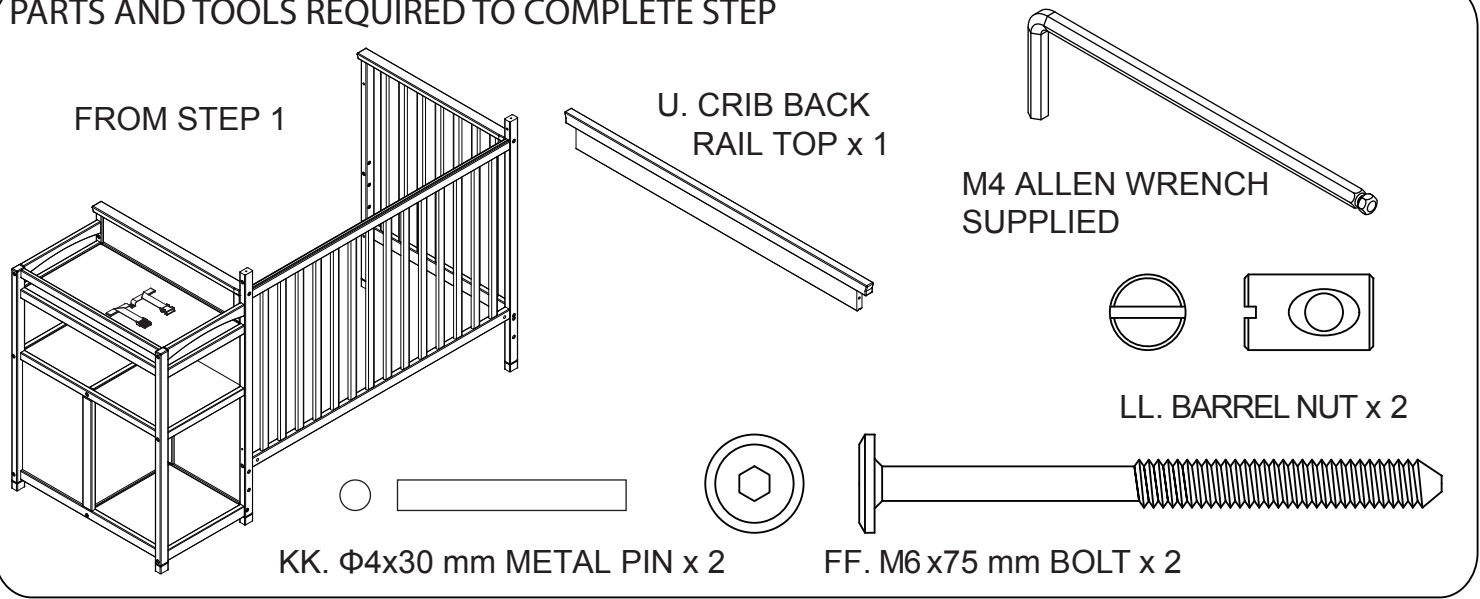

ATTACH (1) CRIB BACK RAIL TOP (PART U) TO THE ASSEMBLY FROM STEP 1 USING (2) $\Phi 4 \times 30$ mm METAL PINS (PART KK), (2) M6 x 75 mm BOLTS (PART FF) AND (2) BARREL NUTS (PART LL). TIGHTEN WITH THE M4 ALLEN WRENCH. USE THE FLAT HEAD SCREWDRIVER TO HOLD THE BARREL NUT IN THE PROPER ALIGNMENT.

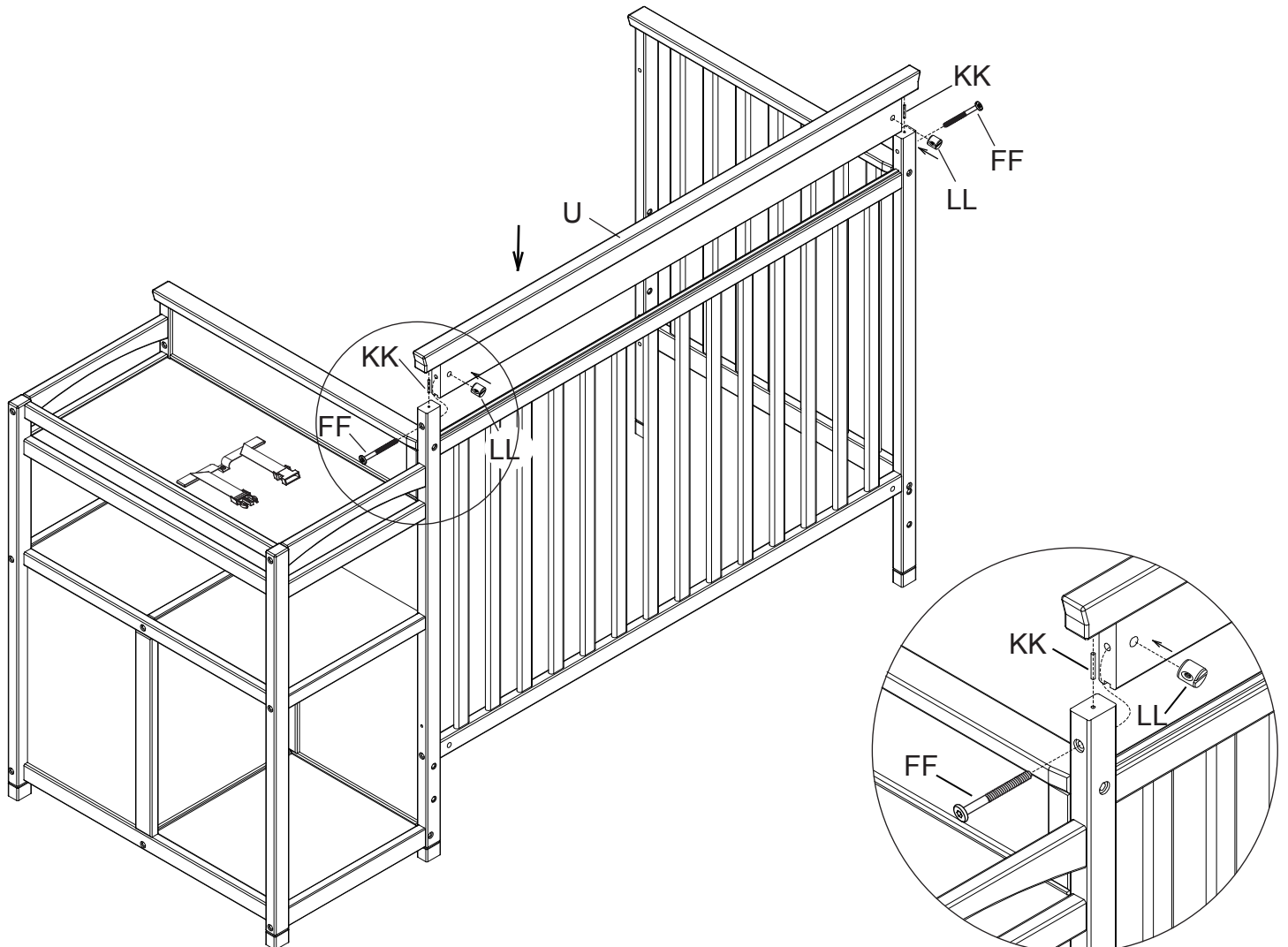

SECTION 2: CRIB ASSEMBLY

STEP 3

PARTS AND TOOLS REQUIRED TO COMPLETE STEP

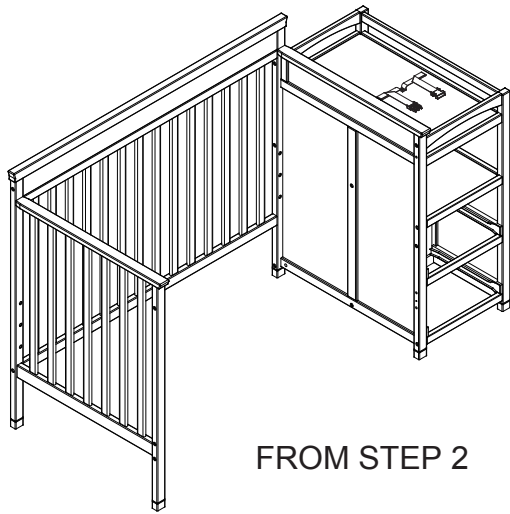

FROM STEP 2

X. STABILIZER BAR x 1

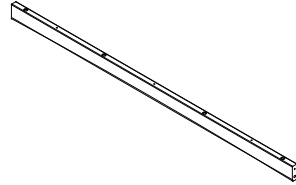

M4 ALLEN WRENCH
SUPPLIED



KK. $\Phi 4 \times 30$ mm METAL PIN x 2

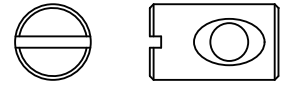

LL. BARREL NUT x 2

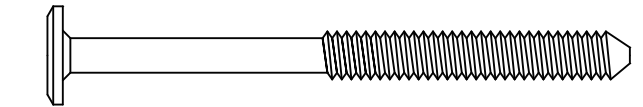
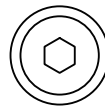

FF. M6x75 mm BOLT x 2

1. INSERT (2) M4x30mm METAL PINS (PART KK) INTO THE HOLE IN EACH OF THE STABILIZER BAR (PART X).
2. INSERT THE METAL PIN INTO THE HOLES IN THE FRONT POST OF THE FINISHED CHANGING TABLE. ATTACH WITH (1) M6x75mm BOLT (PART FF) AND (1) BARREL NUT (PART LL). TIGHTEN WITH THE M4 ALLEN WRENCH. USE THE FLAT HEAD SCREWDRIVER TO HOLD THE BARREL NUT IN THE PROPER ALIGNMENT. REPEAT ABOVE WITH THE CRIB END (PART S). **DO NOT TIGHTEN BOLTS COMPLETELY.** THEY WILL BE TIGHTENED IN SECTION 2 STEP 5.

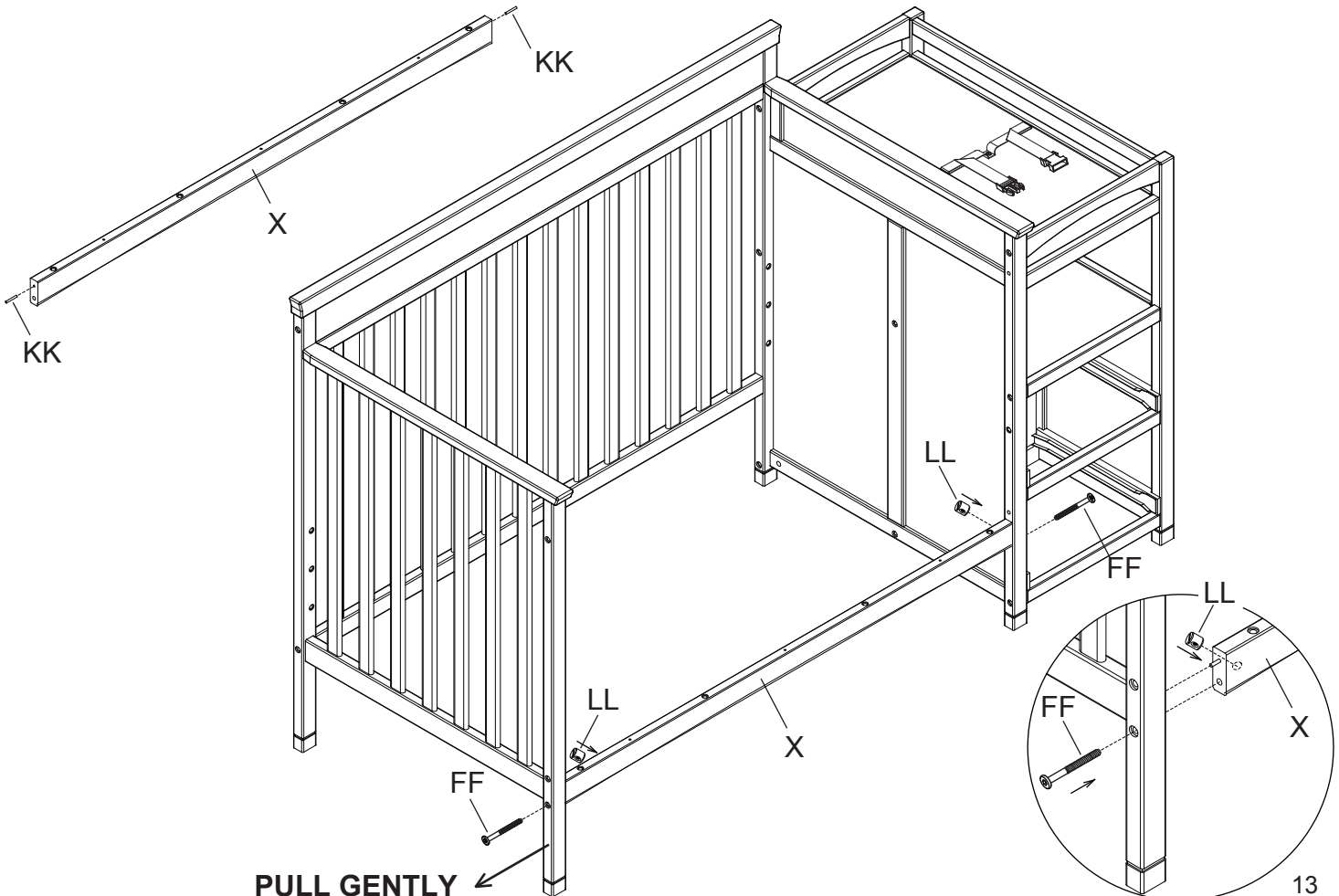

SECTION 2: CRIB ASSEMBLY

STEP 4

PARTS AND TOOLS REQUIRED TO COMPLETE STEP

FROM STEP 3

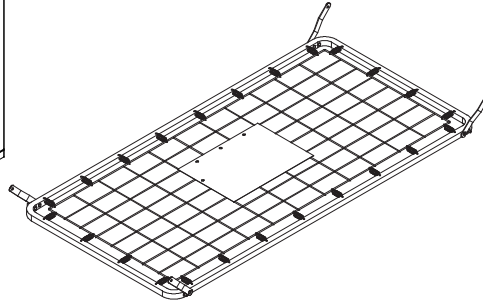
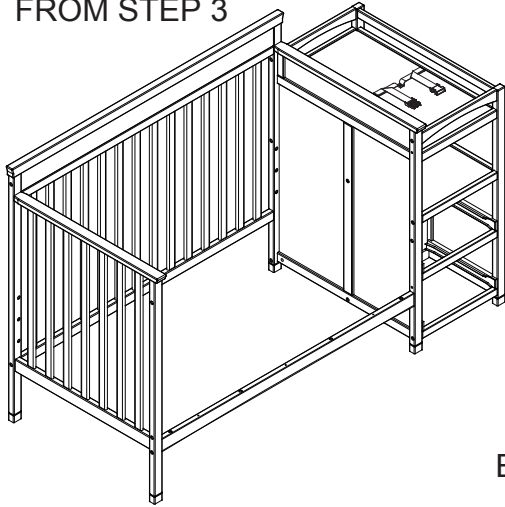

EE. MATTRESS SUPPORT x 1



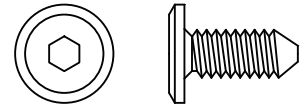

M4 ALLEN WRENCH
SUPPLIED

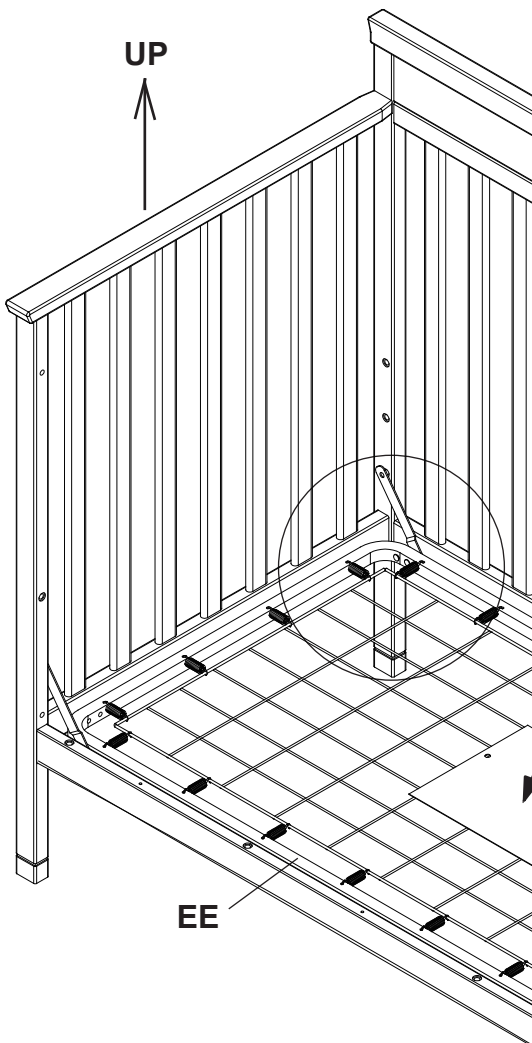

JJ. M6 x 15 mm BOLT x 4

ATTACH THE MATTRESS SUPPORT (PART EE) IN ALL CORNERS USING (1) M6x15 mm BOLT (PART JJ) IN EACH CORNER. TIGHTEN WITH THE M4 ALLEN WRENCH.



THE  WARNINGS PRINTED ON THE POUCH ATTACHED TO THE MATTRESS SUPPORT MUST FACE UP, THE SPRINGS MUST FACE UP.

THIS CRIB HAS (3) ADJUSTMENT POSITIONS, USE THE HIGHEST ONLY FOR NEW BORN, MOVE THE MATTRESS DOWN AS THE CHILD GROWS.

WARNING:

FALL HAZARD: WHEN CHILD IS ABLE TO PULL TO A STANDING POSITION, SET MATTRESS TO LOWEST POSITION AND REMOVE BUMPER PADS, LARGE TOYS AND OTHER OBJECTS THAT COULD SERVE AS STEPS FOR CLIMBING OUT.

 **WARNINGS ON POUCH MUST FACE UP.**

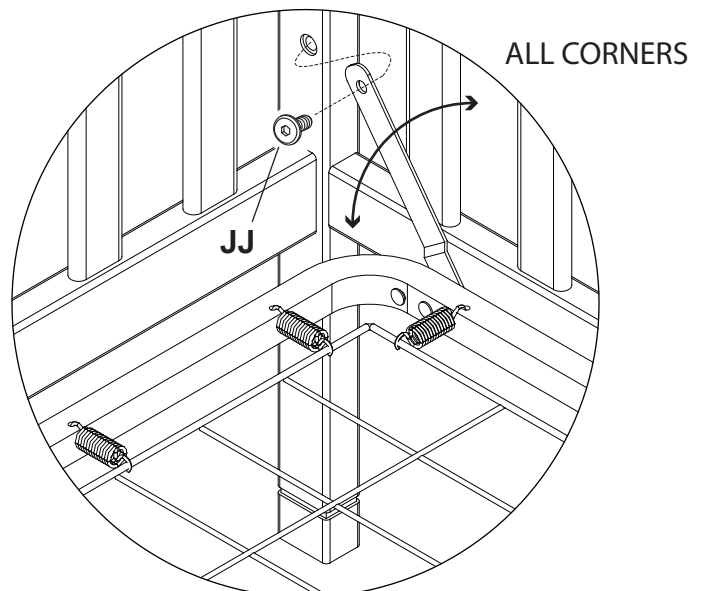

SECTION 2: CRIB ASSEMBLY

STEP 5

PARTS AND TOOLS REQUIRED TO COMPLETE STEP

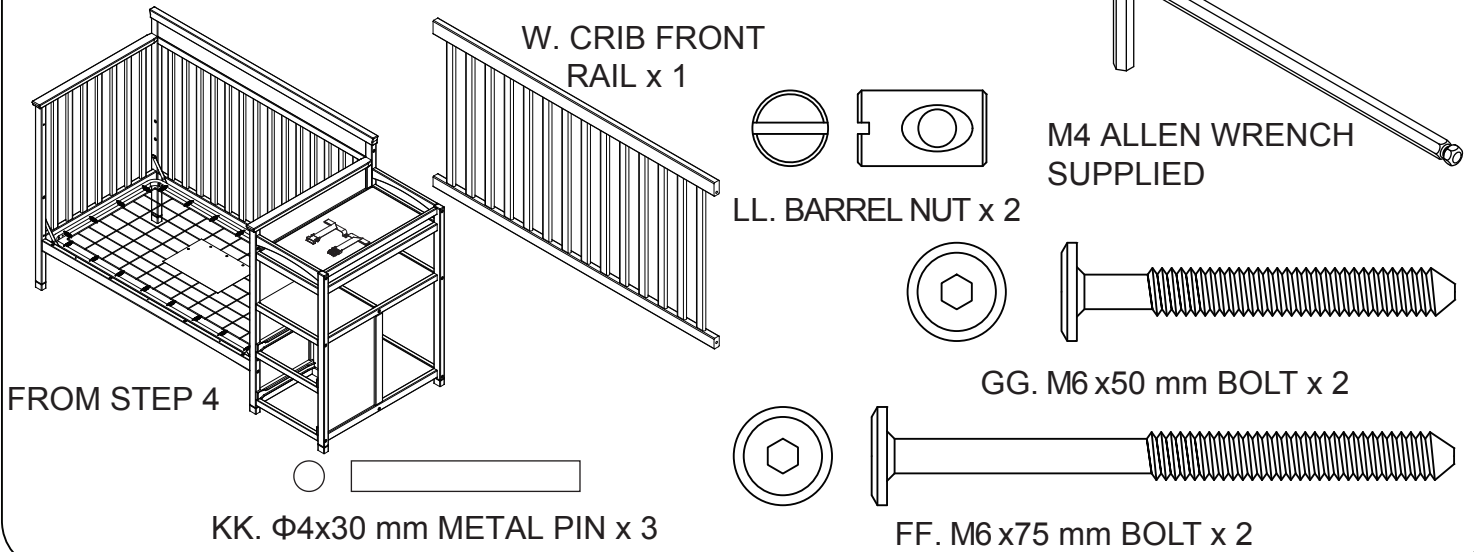

ATTACH THE CRIB FRONT RAIL (PART W) TO THE ASSEMBLY FROM STEP 4 USING (3) Φ 4x30mm METAL PINS (PART KK), (2) M6x50mm BOLTS (PART GG), (2) M6x75mm BOLTS (PART FF) AND (2) BARREL NUTS (PART LL). TIGHTEN ALL BOLTS, INCLUDING THE BOLT INSTALLED LOOSELY IN SECTION 2 STEP 1, 2 AND 3, WITH THE M4 ALLEN WRENCH. USE THE FLAT HEAD SCREWDRIVER TO HOLD THE BARREL NUT IN THE PROPER ALIGNMENT.

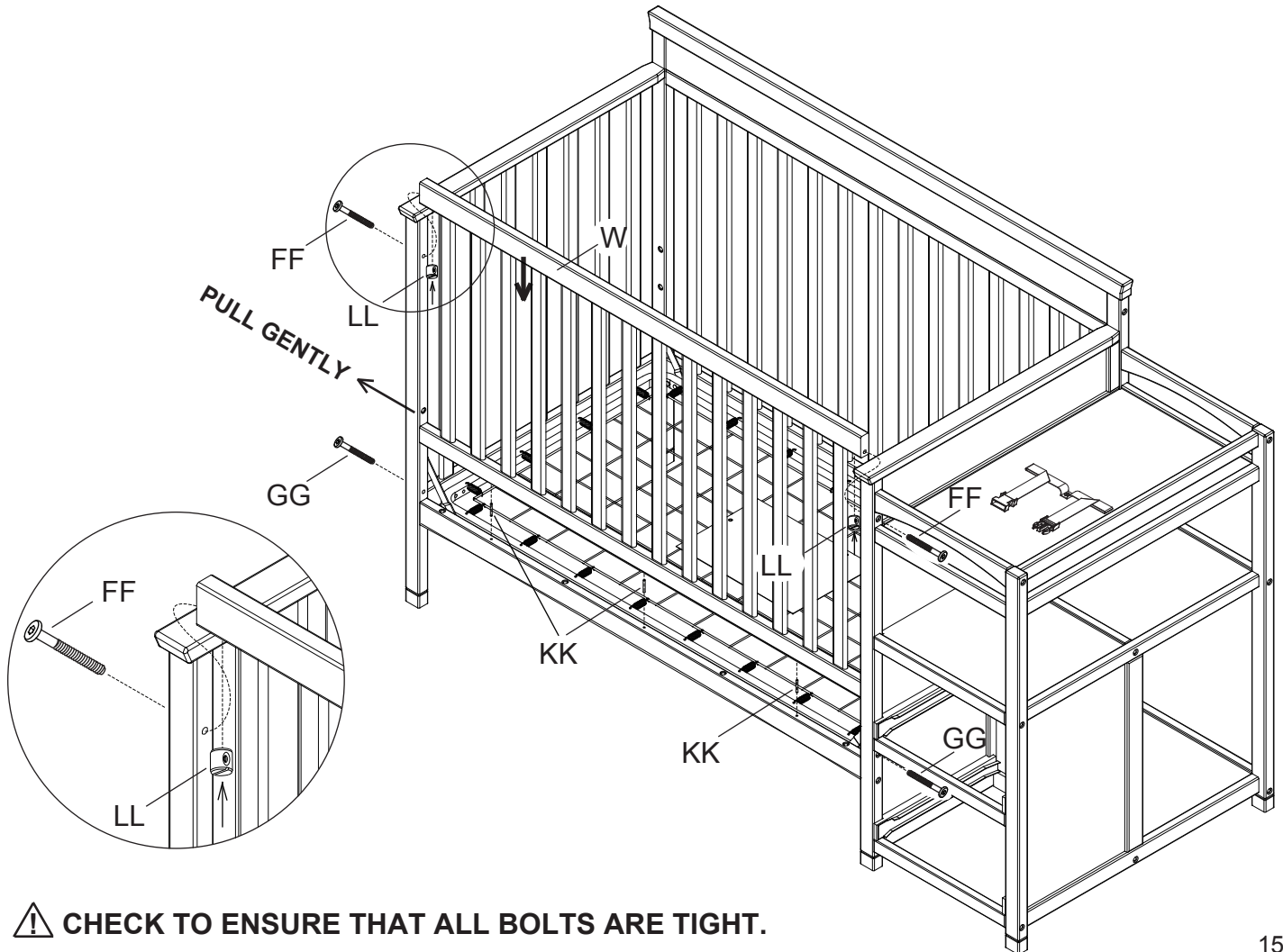

⚠ CHECK TO ENSURE THAT ALL BOLTS ARE TIGHT.

SECTION 2: CRIB ASSEMBLY

STEP 6

PARTS AND TOOLS REQUIRED TO COMPLETE STEP

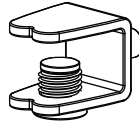
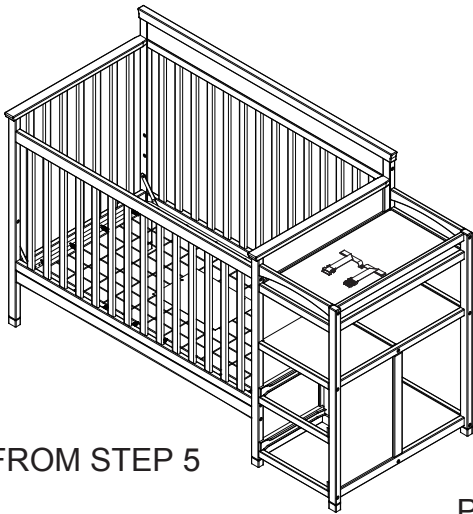

TT. SHELF CLIPS x 4

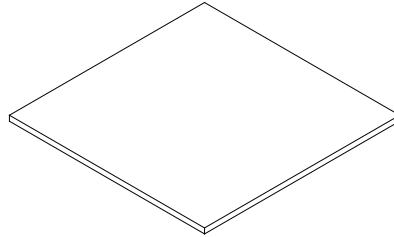

P. CHANGER REMOVABLE SHELF x 1

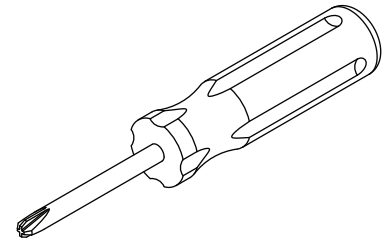

PHILLIPS SCREWDRIVER
NOT SUPPLIED

INSERT THE SHELF CLIPS (PART TT) IN THE HOLES IN THE POSTS OF THE CHANGING TABLE. PLACE THE REMOVABLE SHELVES (PART P) INSIDE THE SHELF CLIPS. TIGHTEN THE SCREWS IN THE SHELF CLIPS WITH THE PHILLIPS SCREWDRIVER.

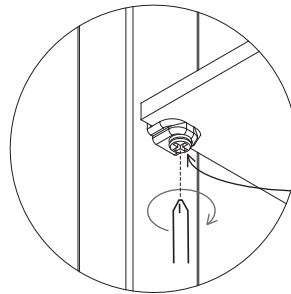

TIGHTEN ALL CLIP SCREWS
TO HOLD SHELVES
IN PLACE.

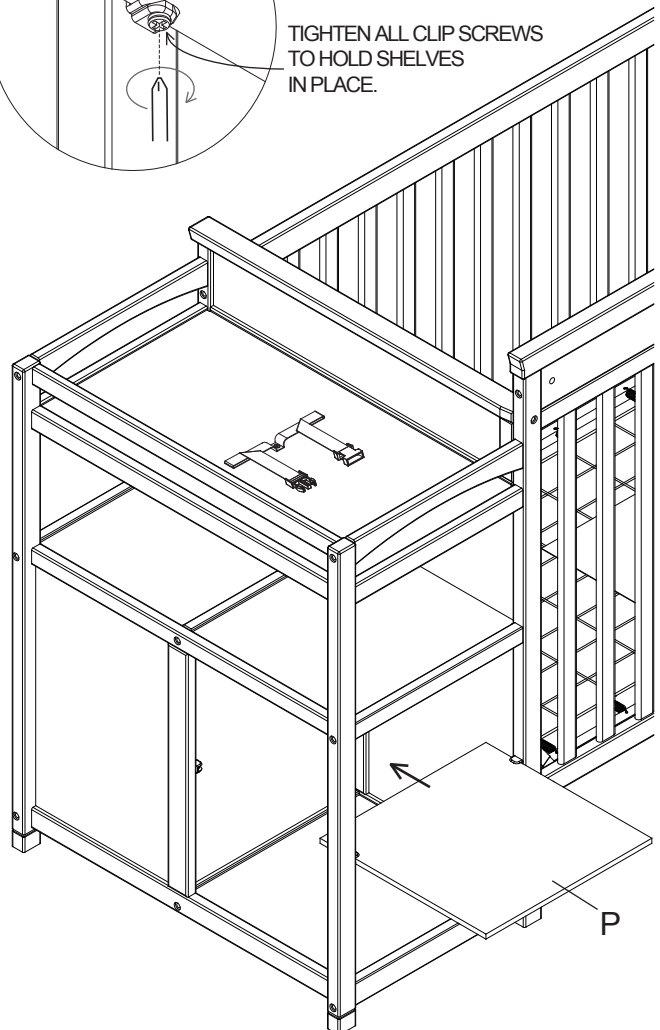
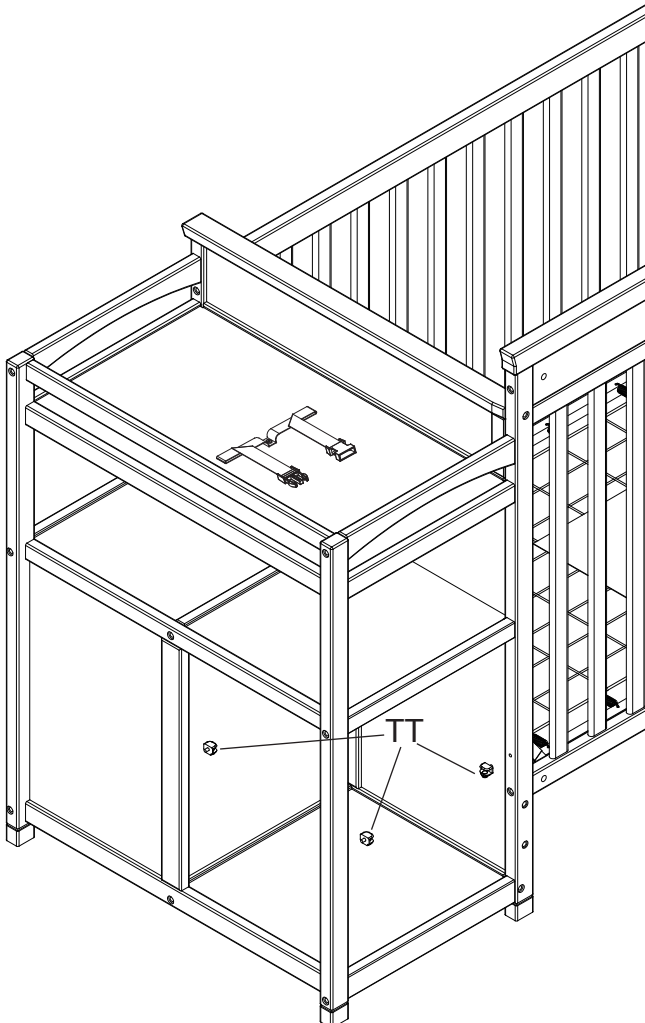

SECTION 3: DRAWER ASSEMBLY

STEP 1

PARTS AND TOOLS REQUIRED TO COMPLETE STEP

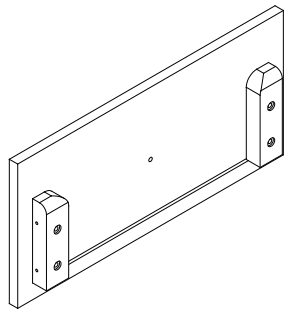

Z. DRAWER FRONT
PANEL x 2

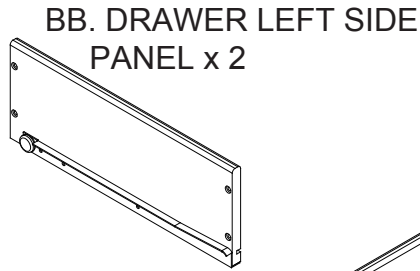

BB. DRAWER LEFT SIDE
PANEL x 2

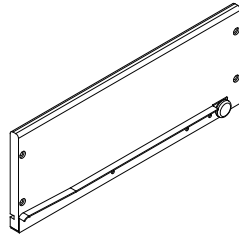

CC. DRAWER RIGHT SIDE
PANEL x 2



MM. 25 mm SCREW x 8

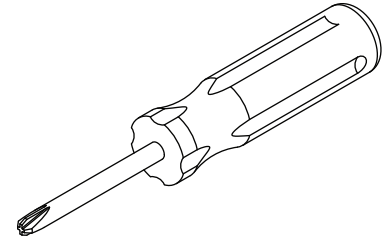

PHILLIPS SCREWDRIVER
NOT SUPPLIED

ATTACH (1) DRAWER LEFT SIDE PANEL (PART BB) AND (1) DRAWER RIGHT SIDE PANEL (PART CC) TO (1) DRAWER FRONT PANEL (PART Z) WITH (4) 25mm SCREWS (PART MM). TIGHTEN WITH THE PHILLIPS SCREWDRIVER. REPEAT ON THE OTHER DRAWER.

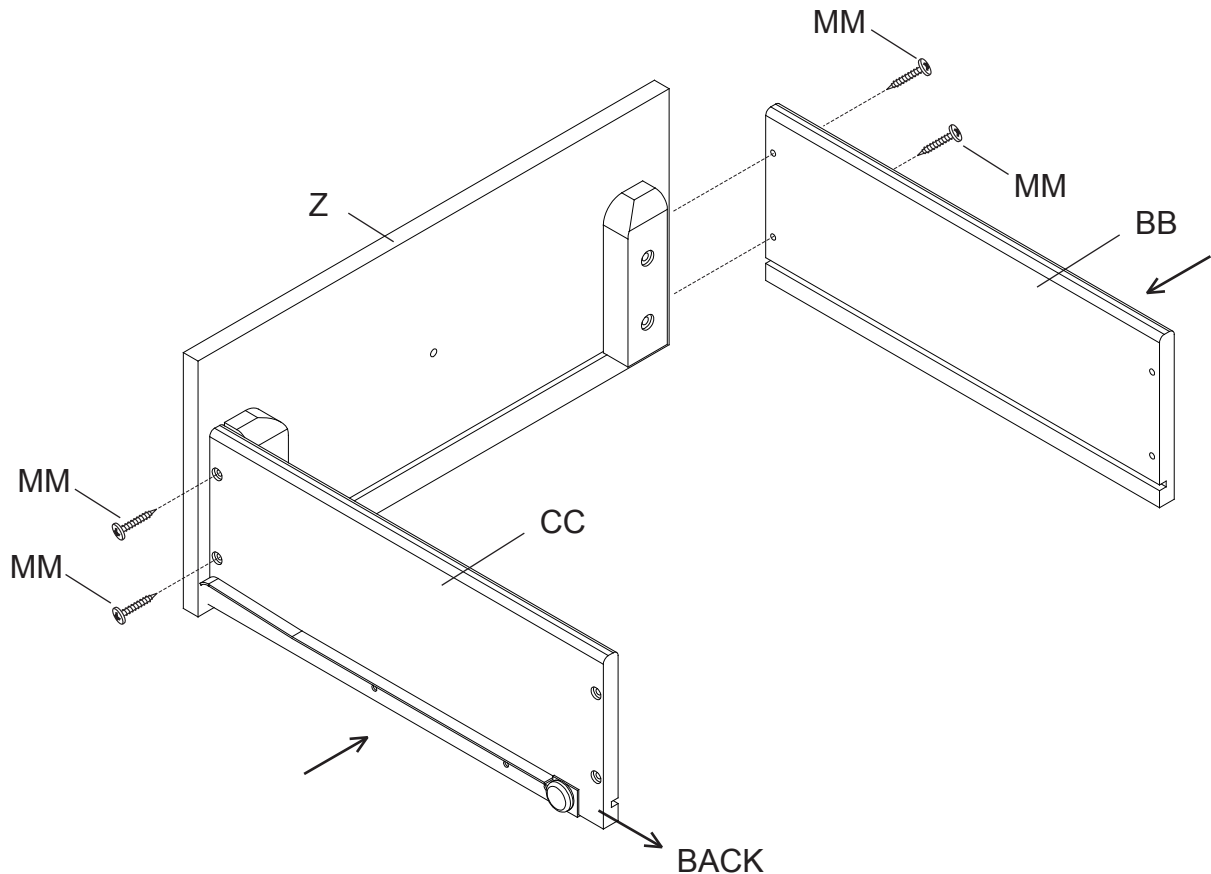

SECTION 3: DRAWER ASSEMBLY

STEP 2

PARTS AND TOOLS REQUIRED TO COMPLETE STEP

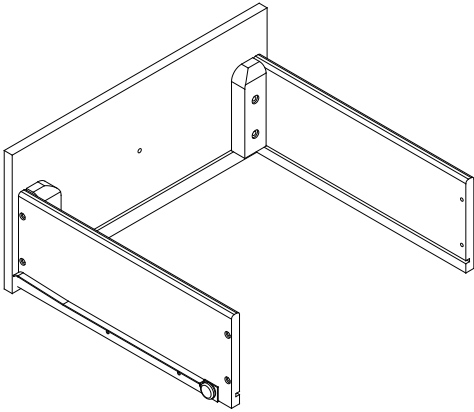

FROM STEP 1

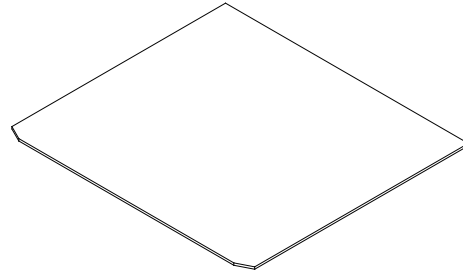

DD. DRAWER BOTTOM PANEL x 2

SLIDE (1) DRAWER BOTTOM PANEL (PART DD) IN THE GROOVES ON THE DRAWER LEFT SIDE PANEL AND DRAWER RIGHT SIDE PANEL, INTO THE GROOVE ON THE DRAWER FRONT PANEL. REPEAT ON THE OTHER DRAWER.

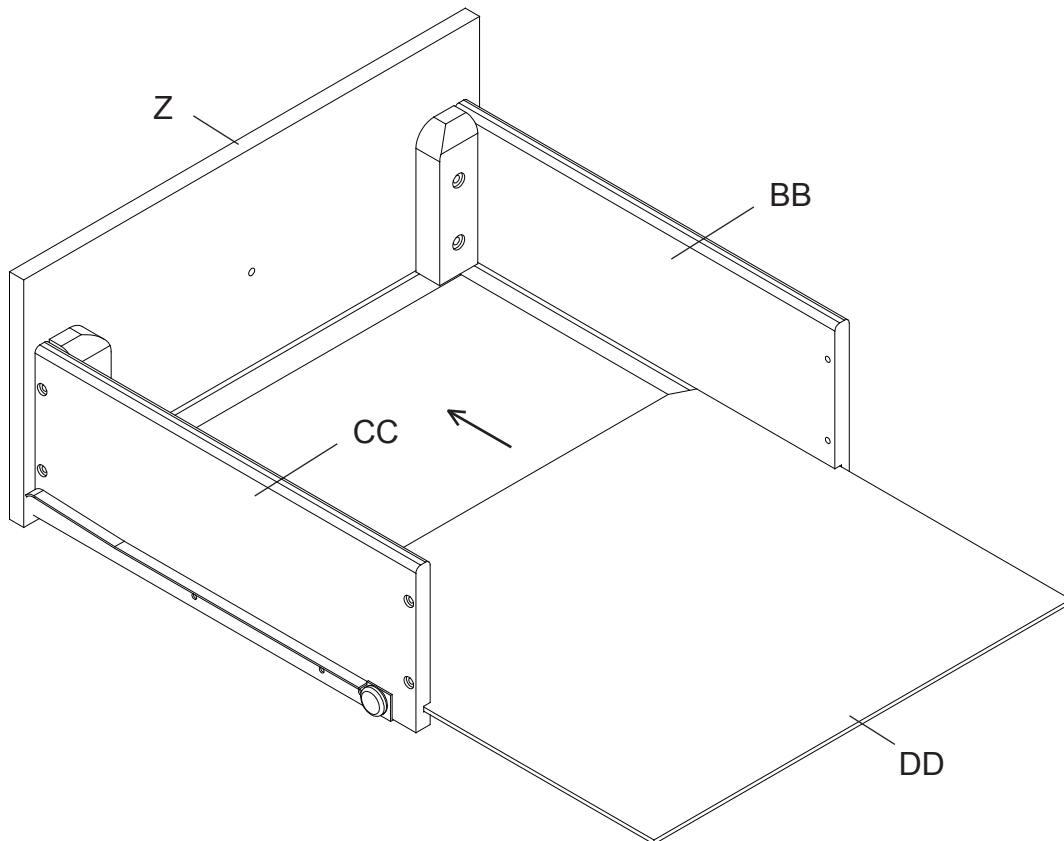

SECTION 3: DRAWER ASSEMBLY

STEP 3

PARTS AND TOOLS REQUIRED TO COMPLETE STEP

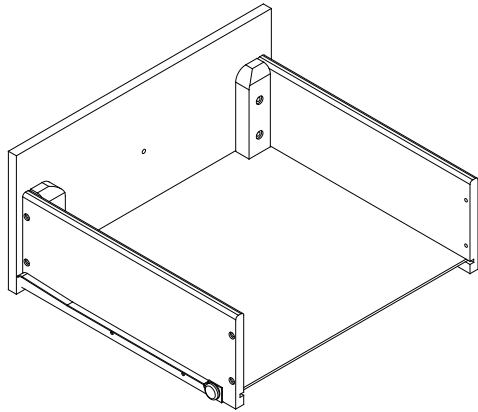

FROM STEP 2



PP. PLASTIC BARREL NUT x 8



NN. 40 mm SCREW x 8

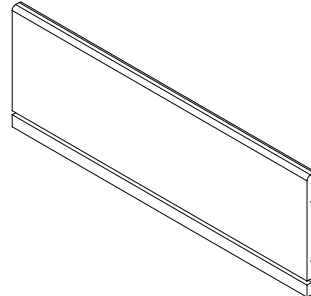

AA. DRAWER BACK PANEL x 2

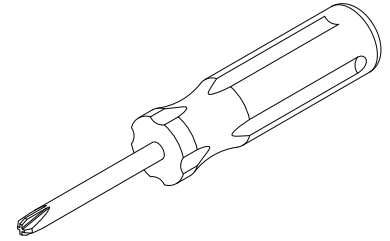

PHILLIPS SCREWDRIVER
NOT SUPPLIED

ATTACH (1) DRAWER BACK PANEL (PART AA) TO THE ASSEMBLY FROM STEP 2 WITH (4) 40mm SCREWS (PART NN) AND (4) PLASTIC BARREL NUT (PART PP). USE THE FLAT HEAD SCREWDRIVER TO HOLD THE PLASTIC BARREL NUT IN THE PROPER ALIGNMENT. TIGHTEN WITH THE PHILLIPS SCREWDRIVER. REPEAT ON THE OTHER DRAWER.

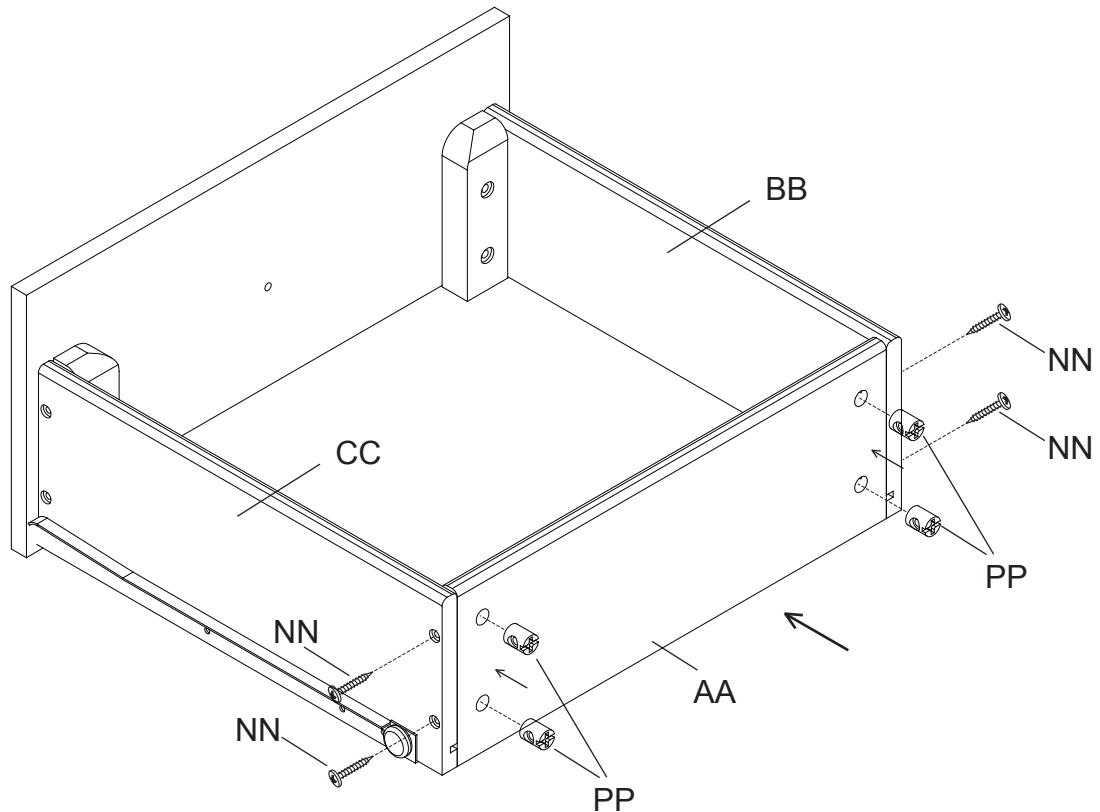

SECTION 3: DRAWER ASSEMBLY

STEP 4

PARTS AND TOOLS REQUIRED TO COMPLETE STEP

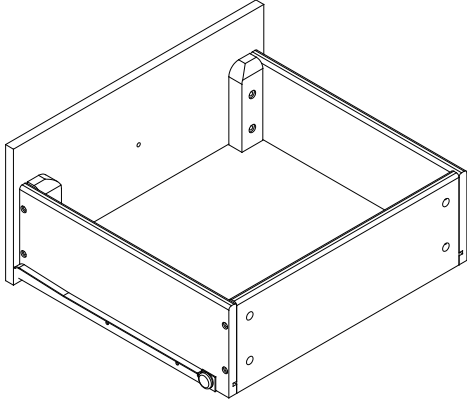

FROM STEP 3

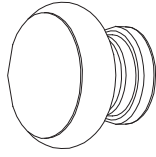

SS. HANDLE x 2

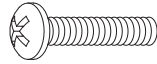

RR. HANDLE BOLT x 2

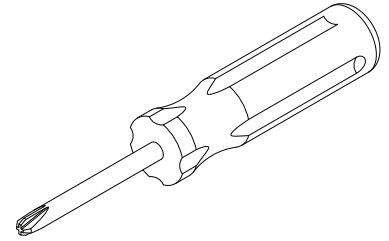

PHILLIPS SCREWDRIVER
NOT SUPPLIED

ATTACH (1) HANDLE (PART SS) TO THE ASSEMBLY FROM STEP 3 WITH (1) HANDLE BOLT (PART RR). TIGHTEN WITH THE PHILLIPS SCREWDRIVER. REPEAT ON THE OTHER DRAWER.

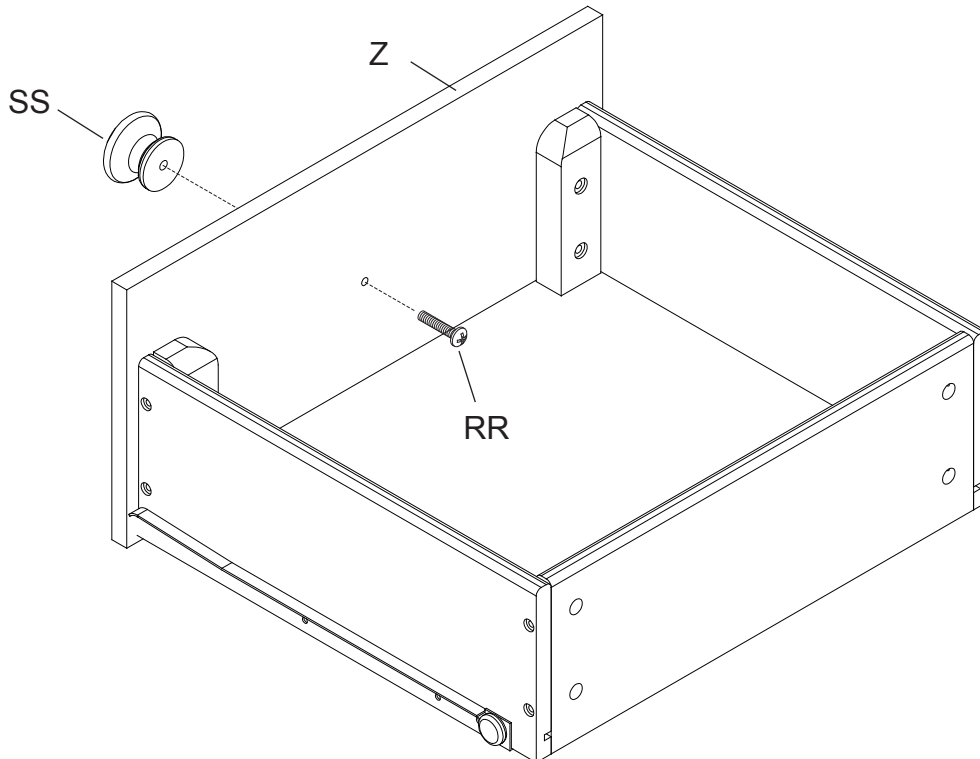

SECTION 3: DRAWER ASSEMBLY

STEP 5

PARTS AND TOOLS REQUIRED TO COMPLETE STEP

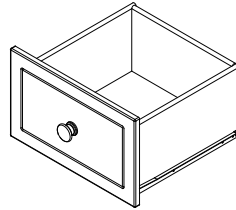
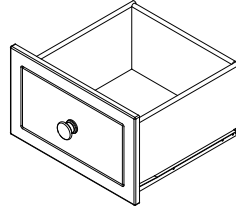
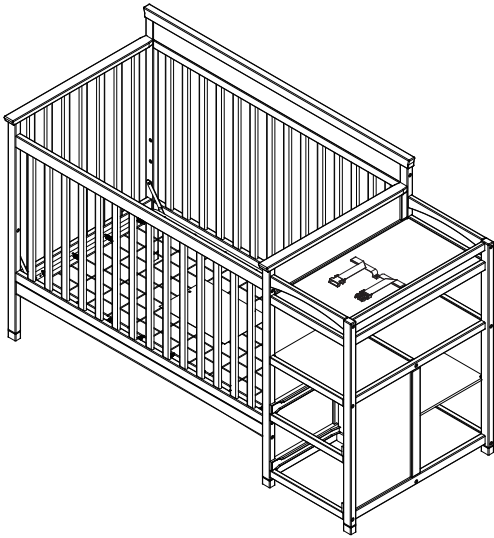

FROM STEP 4

INSERT THE DRAWERS AS SHOWN.

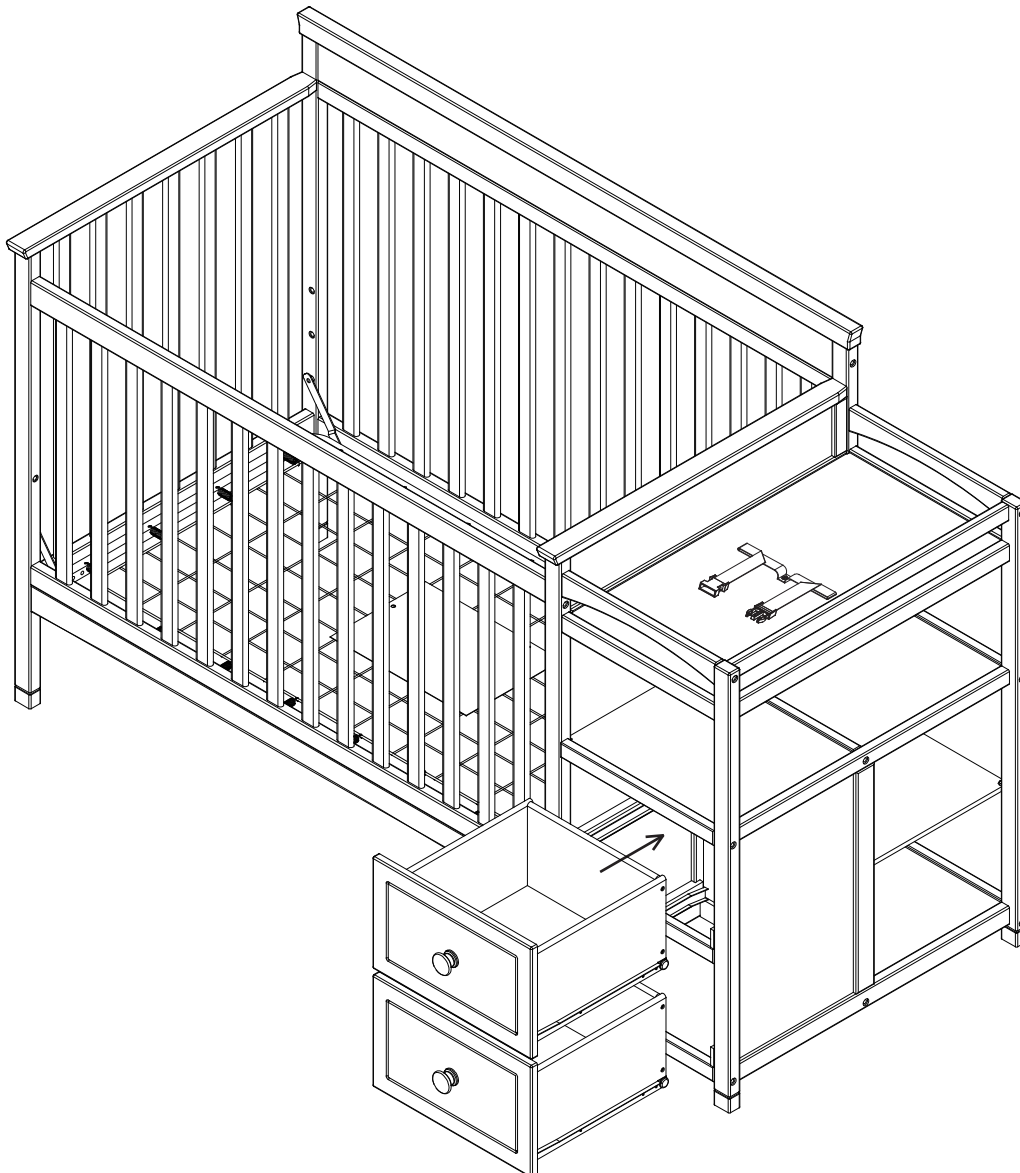

SECTION 4:

STEP 1 CHANGING PAD ATTACHMENT AND USE

PARTS AND TOOLS REQUIRED TO COMPLETE STEP

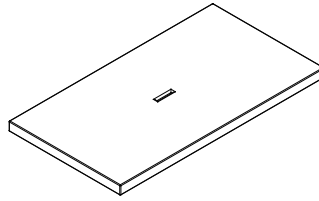
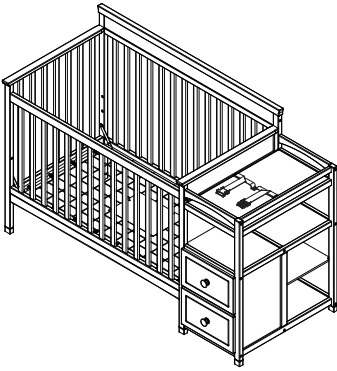

S. CHANGER PAD x 1

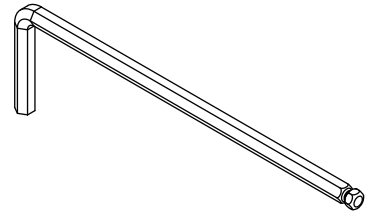

M4 ALLEN WRENCH
SUPPLIED

1. CHECK THAT THE BOLT SECURING THE STRAP IS TIGHT USING M4 ALLEN WRENCH.
2. INSERT THE STRAP THROUGH THE HOLE IN THE CHANGER PAD (PART S).
3. PLACE PAD ON CHANGING SURFACE.

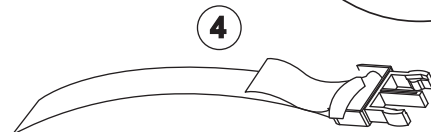
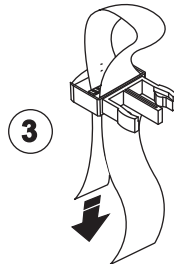
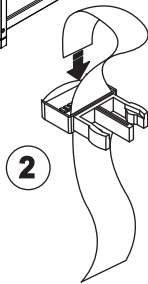
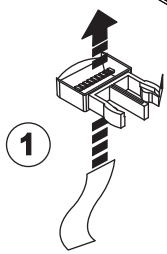
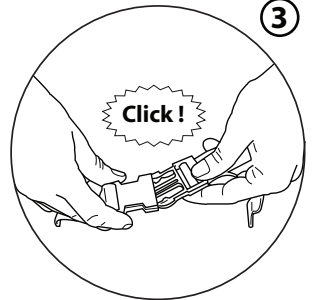
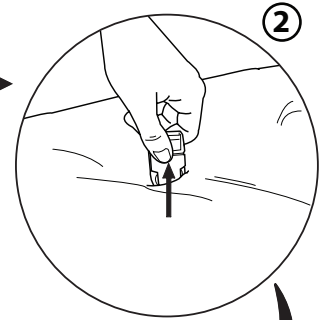
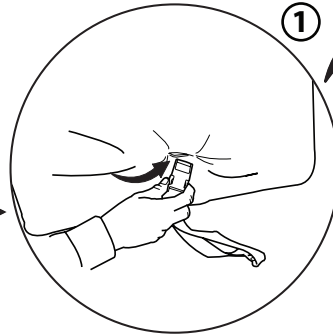
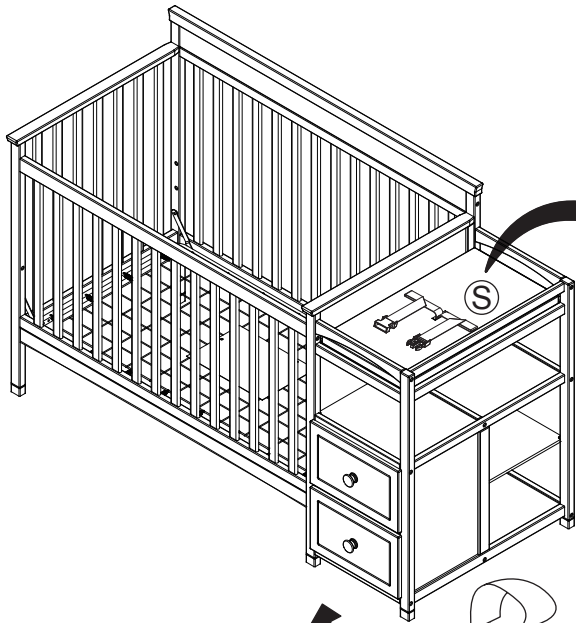

TO FASTEN STRAP - PUTH BUCKLE SIDE TOGETH-
ERBESURE BUCKLE IS FULLY FASTENED TO
SECURE CHILD SAFFELY

TO RELEASE PRESS BOTH TABS AND PULL APART

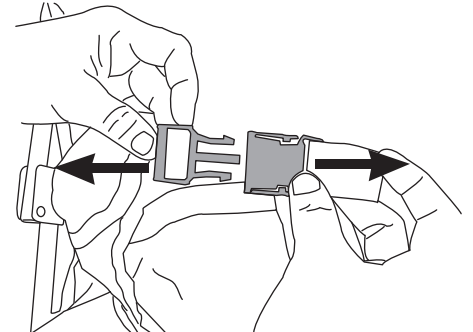
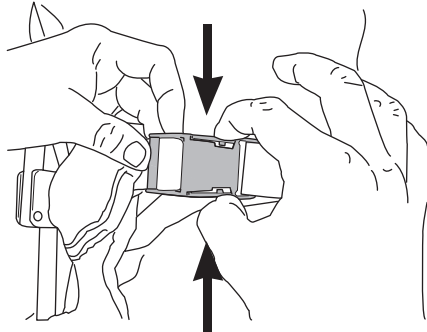
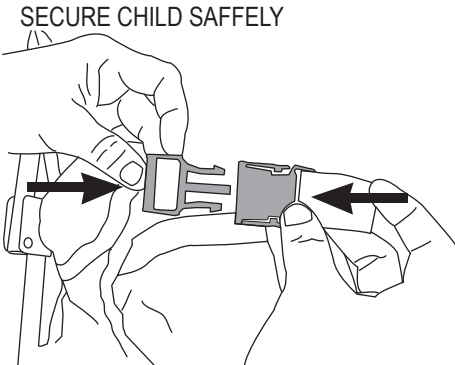

SECTION 4: STEP 2 STORING INSTRUCTION BOOKLET

PARTS AND TOOLS REQUIRED TO COMPLETE STEP



ASSEMBLY INSTRUCTION
BOOKLET

STORE THE ASSEMBLY INSTRUCTION BOOKLET IN THE POUCH ATTACHED TO THE MATTRESS SUPPORT. STORE ALL PARTS AND TOOLS SEPARATELY, IN A SAFE PLACE.

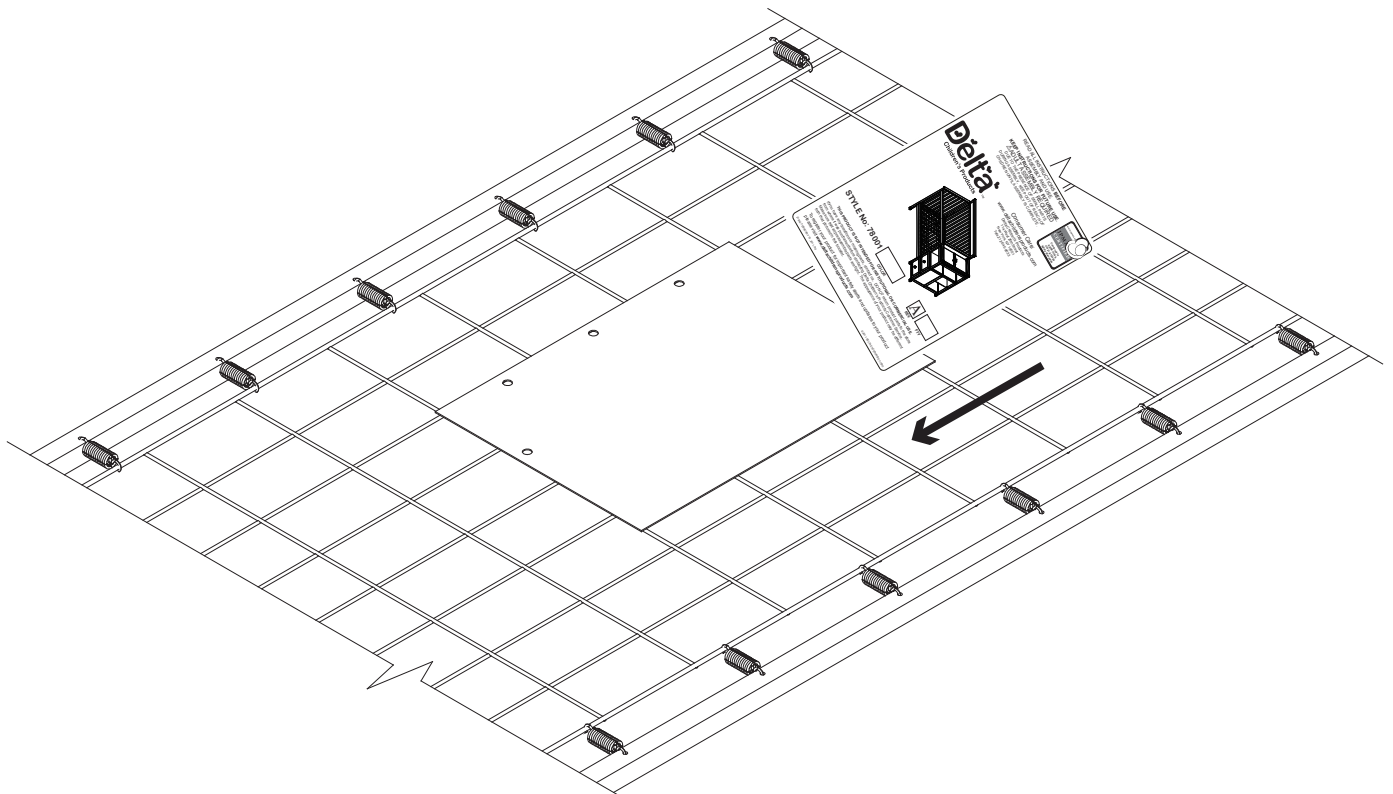

SECTION 5: TODDLER BED CONVERSION

STEP 1

PARTS AND TOOLS REQUIRED TO COMPLETE STEP

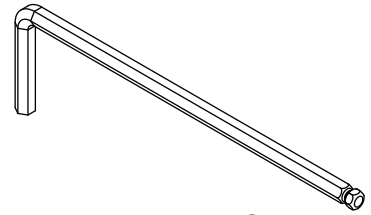

M4 ALLEN WRENCH
SUPPLIED

REMOVE (2) M6x75mm BOLTS (PART FF), (2) BARREL NUTS (PART LL), (2) M6x50mm BOLTS (PART GG) AND (3) Φ 4x30 METAL PINS (PART KK) INSTALLED IN SECTION 2 STEP 5 TO REMOVE THE CRIB FRONT RAIL (PART W) USING THE M4 ALLEN WRENCH.

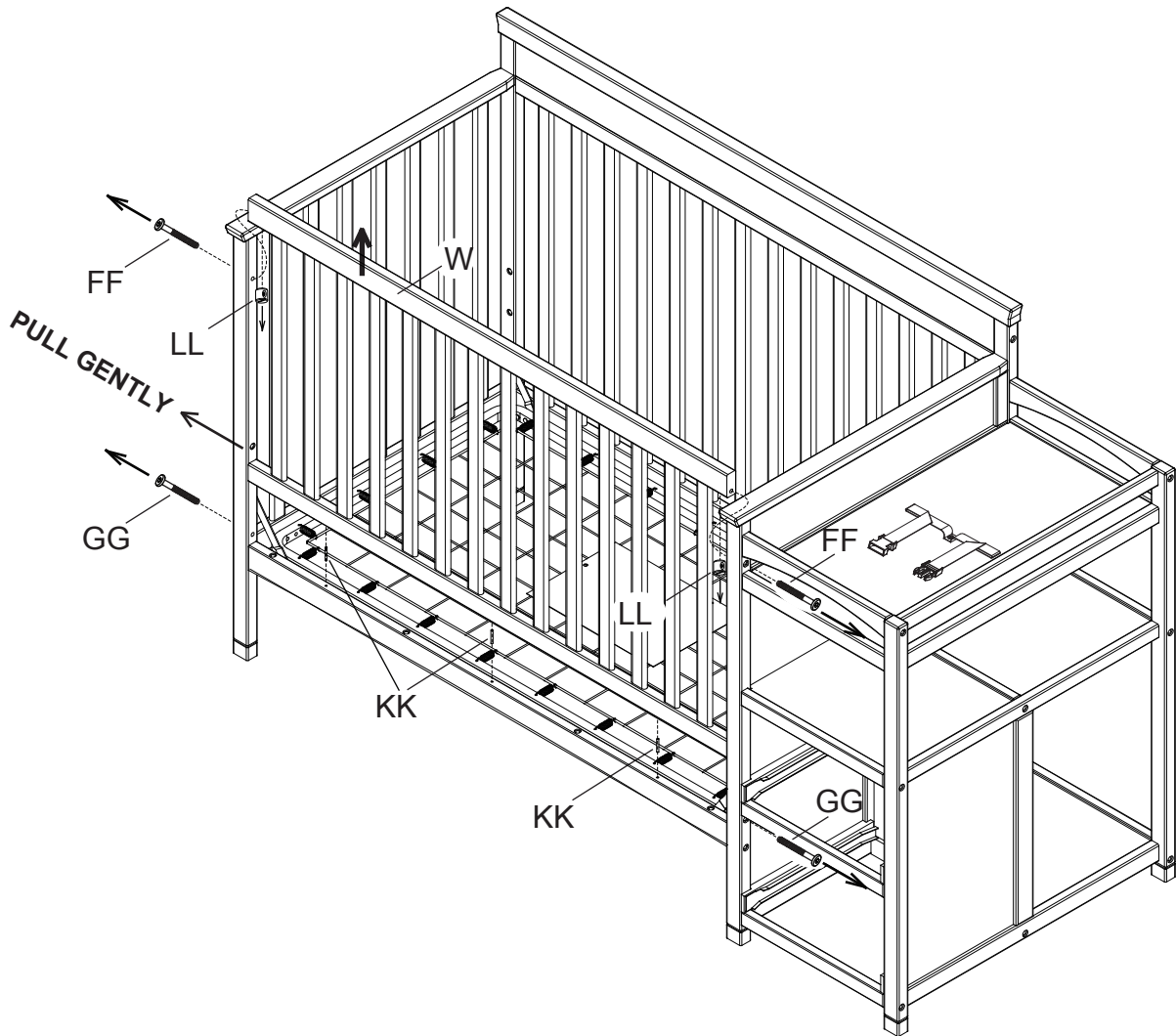

SECTION 5: TODDLER BED CONVERSION STEP 2

⚠ WARNING: SEE PAGE 3 FOR TODDLER BED WARNINGS

THE MATTRESS SUPPORT MUST BE IN THE LOWEST POSITION.
STORE ALL HARDWARE SAFELY.
READ ALL WARNINGS ON PAGE 3

AS SHOWN, USE AS A DAY BED OR LOVE SEAT SOFA.
DO NOT USE WITHOUT STABILIZER BAR INSTALLED.
CHECK TO ENSURE ALL BOLTS ARE TIGHT.

⚠ STABILIZER BAR MUST BE USED
WHEN CONVERTED TO A TODDLER BED.

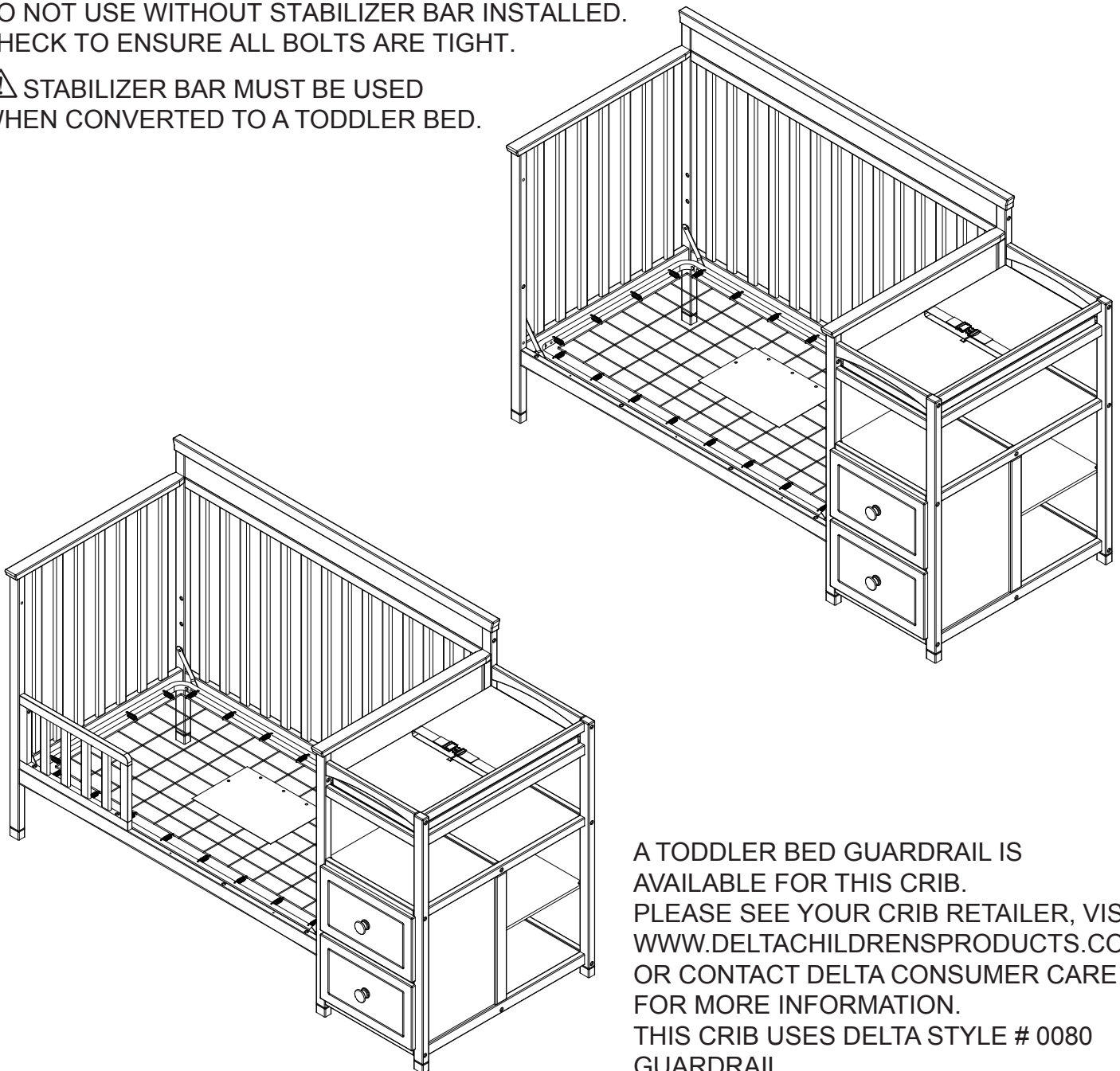

A TODDLER BED GUARDRAIL IS
AVAILABLE FOR THIS CRIB.
PLEASE SEE YOUR CRIB RETAILER, VISIT
WWW.DELTACHILDRENSPRODUCTS.COM
OR CONTACT DELTA CONSUMER CARE
FOR MORE INFORMATION.
THIS CRIB USES DELTA STYLE # 0080
GUARDRAIL.

SECTION 6: FULL SIZE BED CONVERSION

STEP 1

PARTS AND TOOLS REQUIRED TO COMPLETE STEP

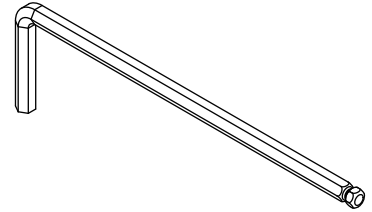

M4 ALLEN WRENCH
SUPPLIED

REMOVE SHELVES AND SHELF CLIPS. DISASSEMBLE THE CHANGER UNIT BY REVERSING ALL STEPS IN SECTION 1: CHANGER ASSEMBLY. REMOVE THE POST FROM THE LEFT CHANGER SIDE (PART A) BY REMOVING THE BOLTS. STORE ALL PARTS CAREFULLY FOR FUTURE USE, SEE PAGE 3 FOR INFORMATION.

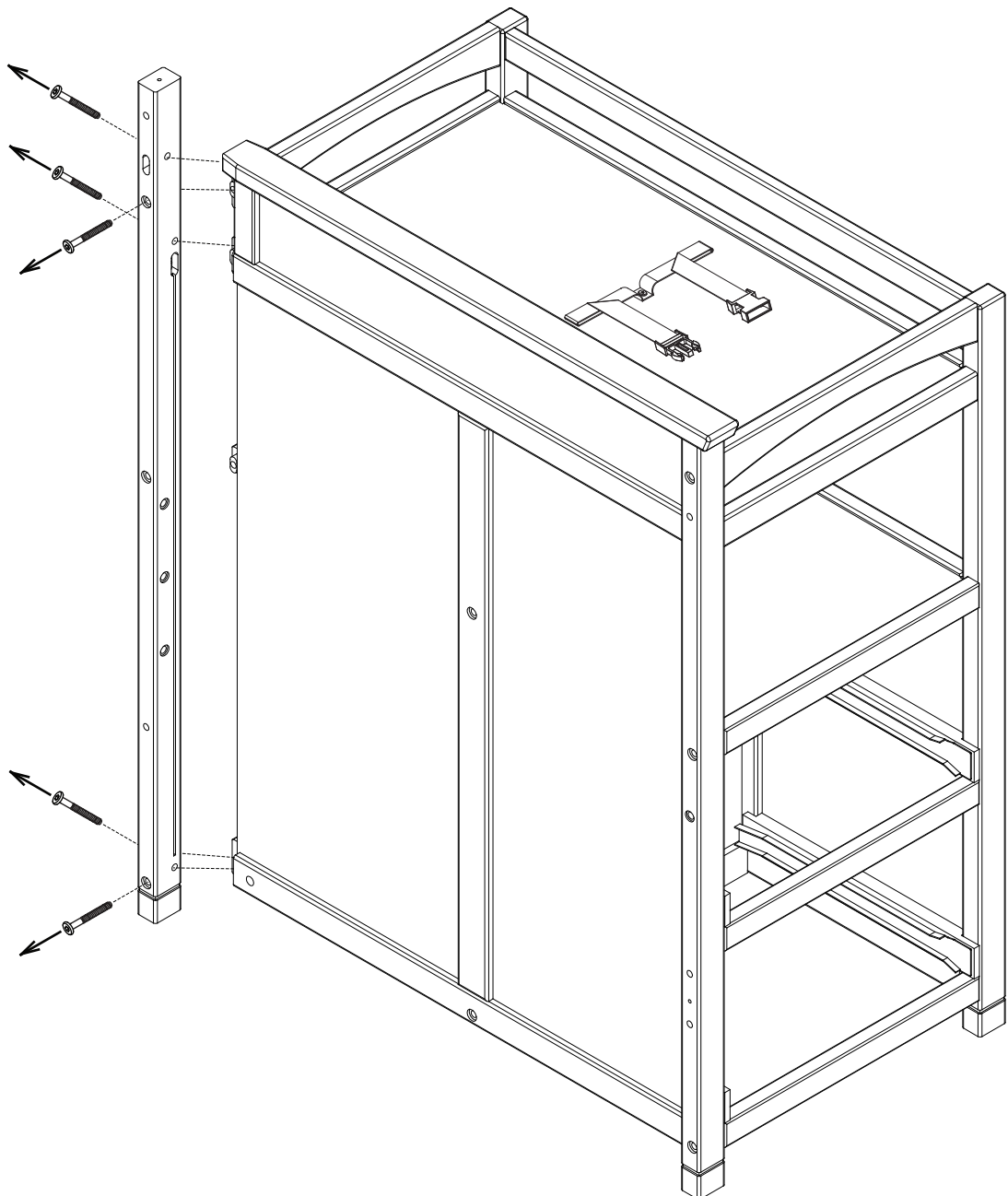

SECTION 6: FULL SIZE BED CONVERSION

STEP 2

PARTS AND TOOLS REQUIRED TO COMPLETE STEP

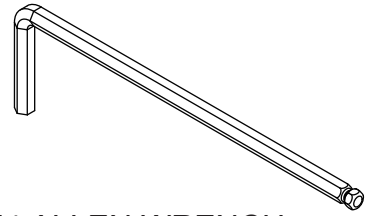

M4 ALLEN WRENCH
SUPPLIED

DISASSEMBLE THE CRIB END BY REMOVING THE PREASSEMBLED BOLTS WITH THE M4 ALLEN WRENCH. ATTACH THE POST REMOVED FROM THE CHANGER IN THE PREVIOUS STEP TO THE END OF THE CRIB BACK SIDE WHERE IT WAS PREVIOUSLY ATTACHED USING (1) $\Phi 4 \times 30$ mm METAL PIN (PART KK), (2) M6x75mm BOLTS (PART FF) AND (2) BARREL NUTS (PART LL). TIGHTEN BOLTS WITH THE M4 ALLEN WRENCH. USE THE FLAT HEAD SCREWDRIVER TO HOLD THE BARREL NUT IN THE PROPER ALIGNMENT. STORE ALL PARTS AND HARDWARE IN A SAFE PLACE. SEE PAGE 3 FOR INFORMATION.

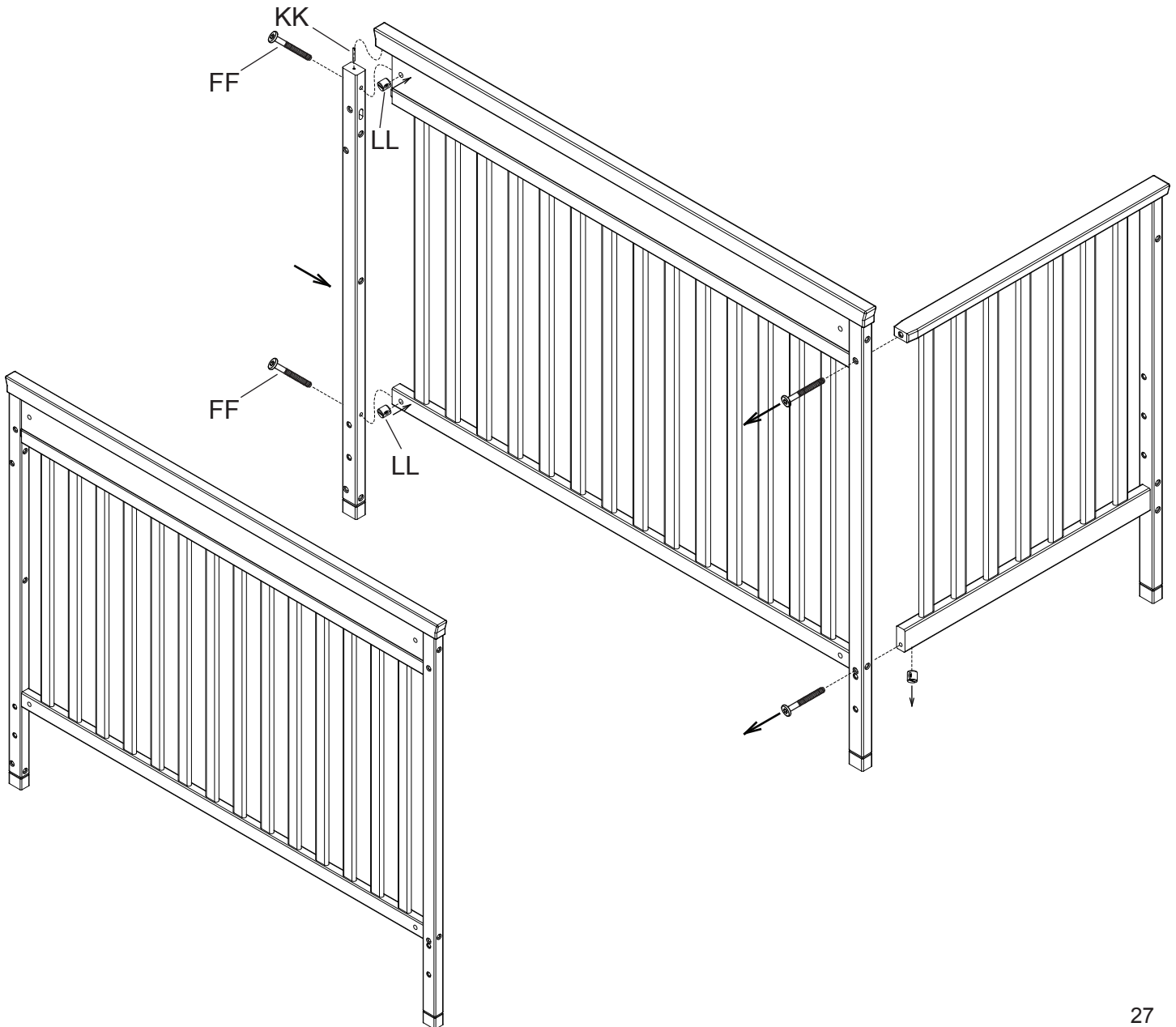

SECTION 6: FULL SIZE BED CONVERSION

STEP 3

PARTS AND TOOLS REQUIRED TO COMPLETE STEP



FROM SECTION 6
STEP 2

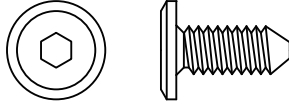

JJ. M6 x15 mm BOLT x 4

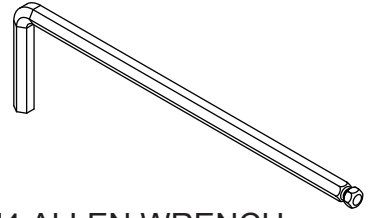

M4 ALLEN WRENCH
SUPPLIED

ATTACH BED FRAME TO THE HEADBOARD (FROM SECTION 6 STEP 2) USING (4) M6x15mm BOLTS (PART JJ). FOLLOW ALL INSTRUCTIONS SUPPLIED WITH THE BED FRAME.

NOTE: BED FRAME SYSTEM IS NOT INCLUDED, SEE YOUR FURNITURE OR MATTRESS RETAILER. CONTACT DELTA CHILDREN'S PRODUCTS FOR INFORMATION OR WITH QUESTIONS.

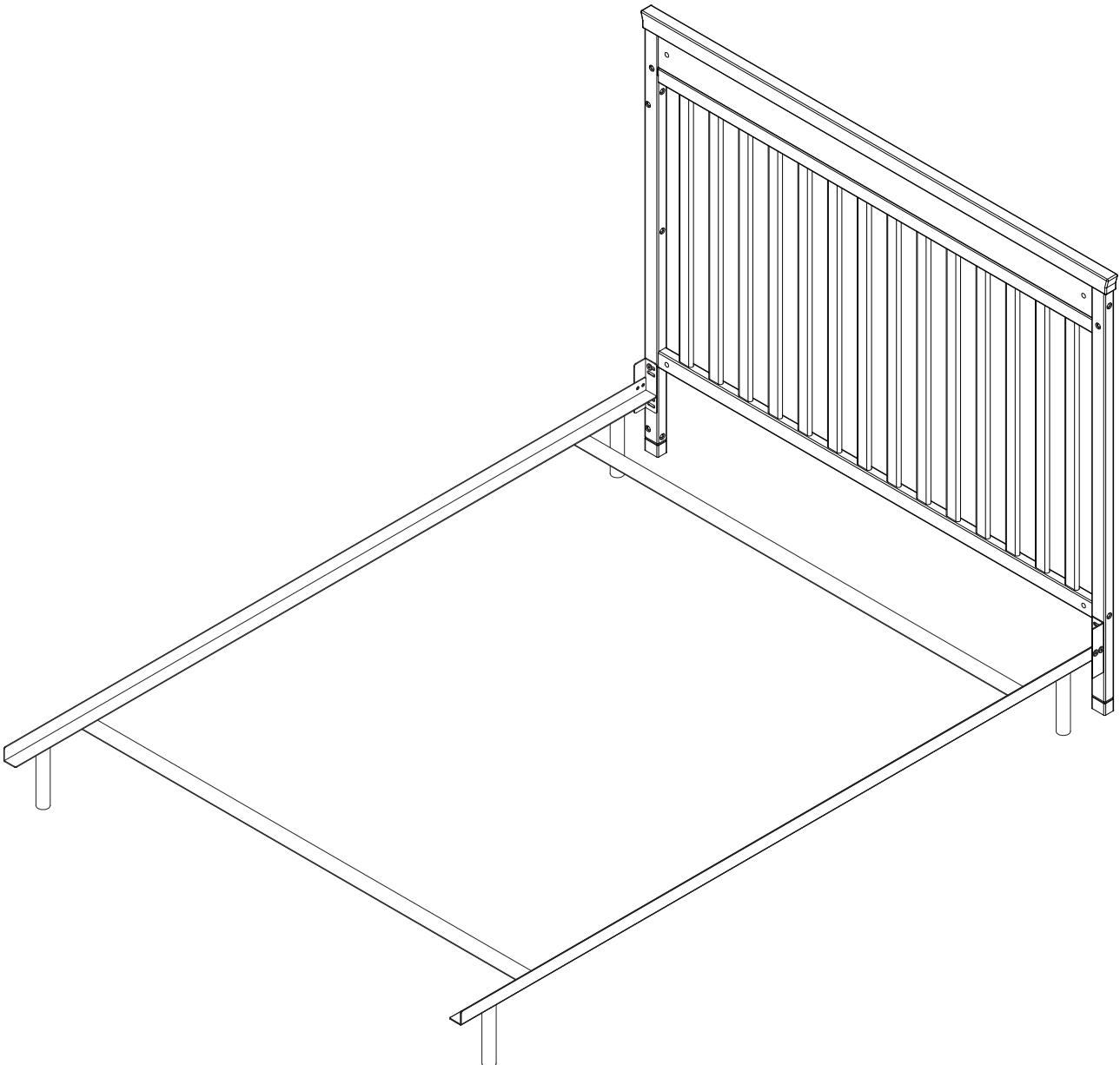



Children's Products

Consumer Care:

www.deltachildrenproducts.com

Delta Children's Products

114 West 26th Street

New York, NY 10001

Tele. 212-645-9033

Warranty: This Delta Crib is warranted to be free from defects for a period of 1 year from the date of purchase under normal use. This warranty extends only to the original retail purchaser and is valid only when supplied with proof of purchase, or if received as a gift, when the registration is on file with Delta.

To register your product for important safety alerts and updates to your product please visit **www.deltachildrenproducts.com**

Please do not return this item to the store before contacting us about missing parts or with any questions.

To report a problem, please log on to **www.deltachildrenproducts.com** and click the Consumer Care Tab, or contact us by phone at (212) 645-9033.

In the event that you need to contact our customer service department please have the Style Number and Lot Number available. Use the space below to make note of those numbers. They can be found on the label on the Crib End bottom rail.

Style No.: _____

Lot No. : _____

Pack Date: _____

Date of Purchase: _____ (you should also keep your receipt)