



Read all instructions before assembly and use.  
**KEEP INSTRUCTIONS FOR FUTURE USE.**

**⚠ ADULT ASSEMBLY REQUIRED**

Due to the presence of small parts during assembly, keep out of reach of children until assembly is complete.

## Convertible Bookcase

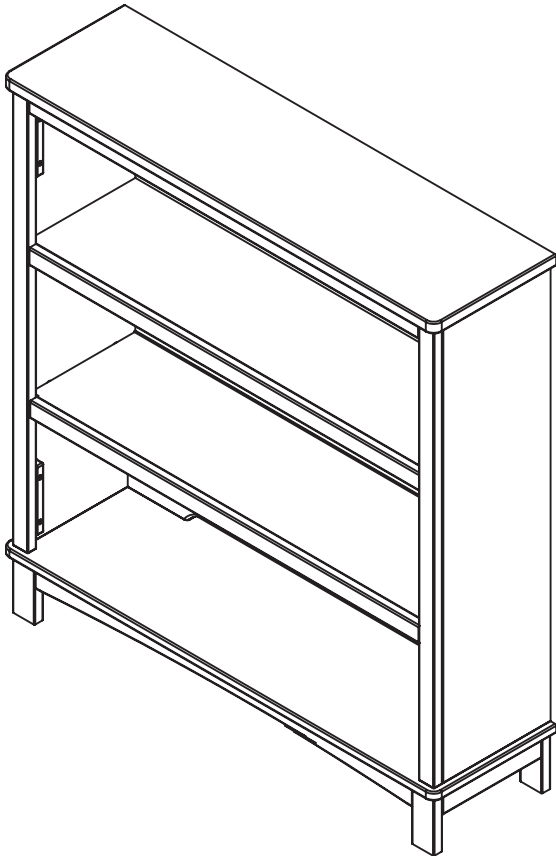

Consumer Care:  
[www.DeltaChildren.com](http://www.DeltaChildren.com)

Delta Children's Products  
114 West 26th Street  
New York, NY 10001  
Tele.212-645-9033

Style #: 76300

Lot: \_\_\_\_\_

Date: \_\_\_\_\_



**THIS PRODUCT IS NOT INTENDED FOR  
INSTITUTIONAL OR COMMERCIAL USE.**

When contacting Delta Consumer Care please reference the above information. Before contacting Delta Consumer Care please ensure that the information above matches the information found on the label on the *Back Panel*, please reference the information found on the product when contacting Delta Consumer Care.

To register your product for important safety alerts and updates to your product please visit [www.DeltaChildren.com](http://www.DeltaChildren.com) and click on Product Registration.

**NOTES ON ASSEMBLY:**

- During the assembly process whenever using screws or bolts, check each by placing the screw/bolt on the diagram of the item which is drawn actual size and design. Be sure to use the proper size and shape specified in the instructions.
- To assemble this unit you may be required to place the unit on it's side and face. It is strongly recommended that assembly is done on a soft, non-abrasive surface (such as the foam packing wrap) to avoid damaging the finish.

**NOTES ON USE:**

Keep children and others safe by following these simple rules:

- **Do not** allow any child to play on furniture
- **Do not** allow climbing on any piece of furniture.
- **Do not** allow hanging from any piece of furniture.
- Always monitor your child's activity when in the nursery.

**NOTES ON CARE AND MAINTENANCE:**

- **Do not** scratch or chip the finish.
- Inspect the product periodically, contact Delta Children's Products for replacement parts or questions.
- **Do not** store the product or any parts in extreme temperatures and conditions such as a hot attic or a damp, cold basement. These extremes can cause a loss of structural integrity.
- To preserve the luster of the high quality finish on your product, it is recommended to place a doily or felt pad under any items you place on the finish.
- Clean with a damp cloth, then a dry cloth to preserve the original luster and beauty of this fine finish.
- Do not** use abrasive chemicals.
- Do not** spray cleaners directly onto furniture.
- Lift slightly when moving on carpeting to prevent leg breakage.
- Use of a vaporizer near furniture will cause wood to swell and finish to peel.

**PARTS:** Hardware kits part# 25119 For colors 988, 989 and 986

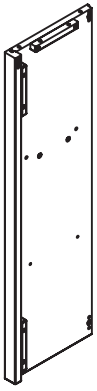

A. Left Side x1  
Part# 25103

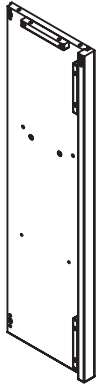

B. Right Side x1  
Part# 25104

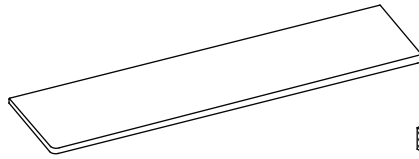

F. Top x1  
Part# 25110

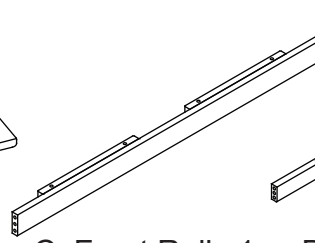

C. Front Rail x1  
Part# 25105

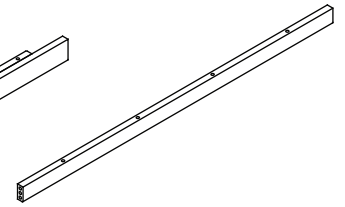

D. Top Back Rail x1  
Part# 25106

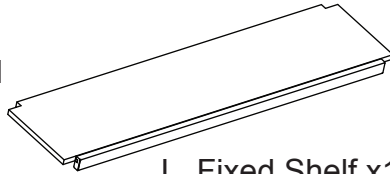

L. Fixed Shelf x1  
Part# 25108

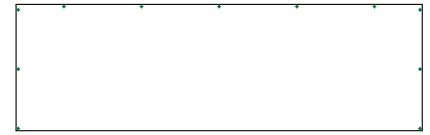

G. Back Panel-Upper x1  
Part# 25111



E. Bottom Back Rail x1  
Part# 25107

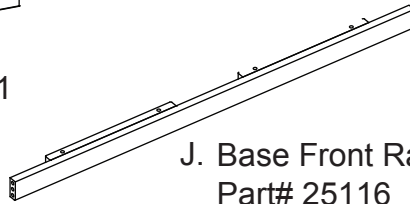

J. Base Front Rail x1  
Part# 25116



H. Back Panel-Middle x1  
Part# 25112

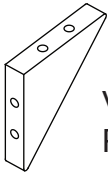

V. Base Corner Brace x2  
Part# 24322

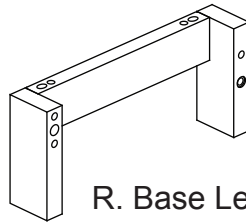

R. Base Left Side x1  
Part# 25117



T. Back Panel-Lower x1  
Part# 25113



U. Joint Cover x1  
Part# 25114

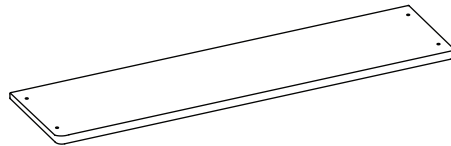

N. Base Top x1  
Part# 25115

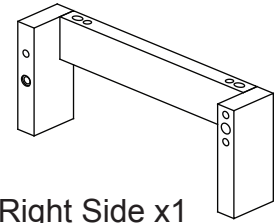

S. Base Right Side x1  
Part# 25118



K. Removable Shelf x1  
Part# 25109

**PARTS:** Hardware kits part# 25119

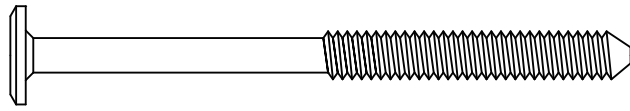
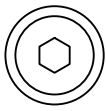

AA. 80mm Bolt x4

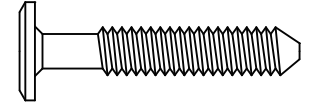
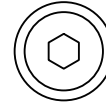

GG. 30mm Bolt x20

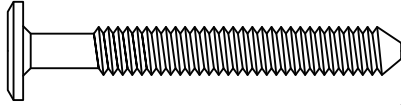
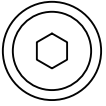

CC. 50mm Bolt x4

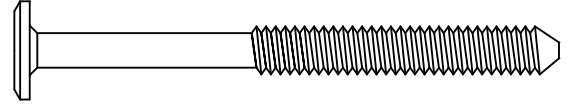
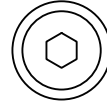

DD. 70mm Bolt x8

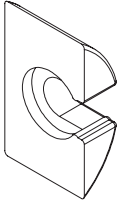

BB. Plastic Crescent Washer x8

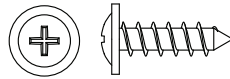

EE. Washer Head Screw 15mm x 47



FF. WOOD DOWEL 30mm x24

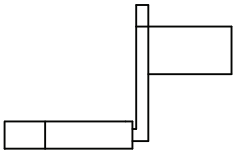
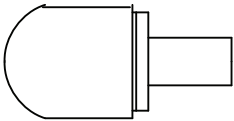

HH. shelf Support x4

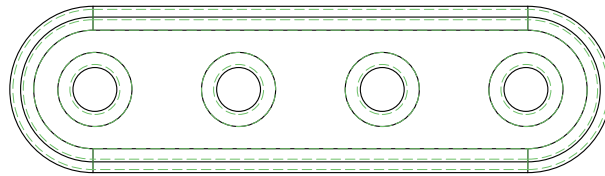

KK. Metal Plate x2

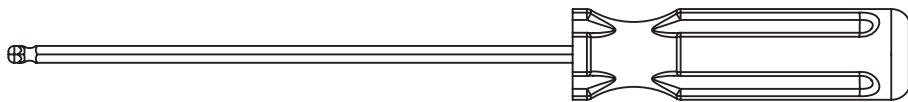

M4 Ballend Screw Driver Hex Wrench x1



4mm Hex Wrench x1

Phillips Screwdriver  
(not supplied)

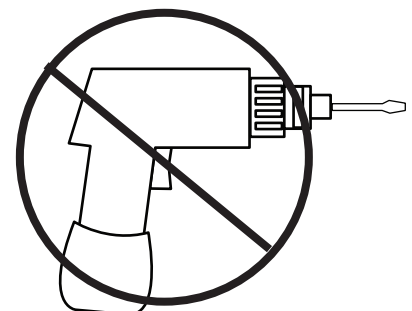
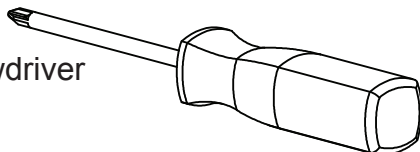

# HARDWARE SYSTEM - REVIEW BEFORE ASSEMBLY

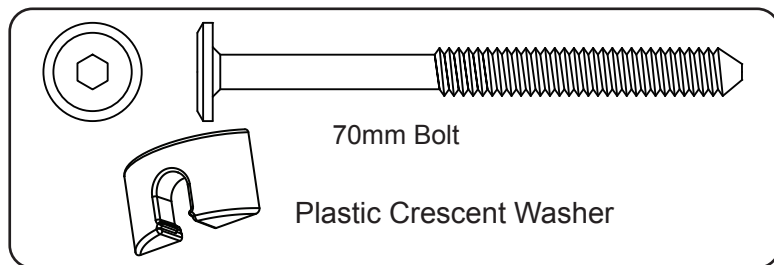

1. Insert the Dowels in the Rail into the holes in the Post.

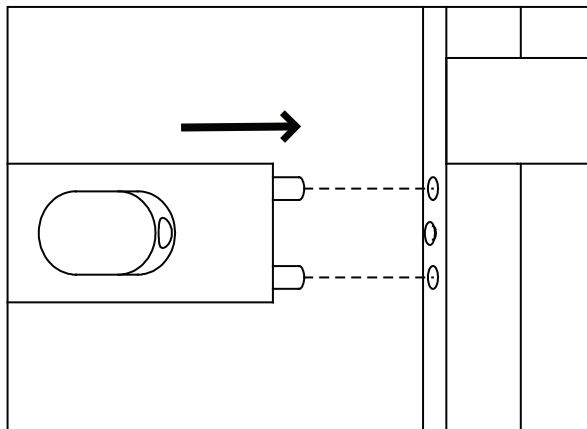

2. Align the bolt with the hole in the end of the rail, align the dowels in the end of the rail with the holes in the post. Slide together until tight.

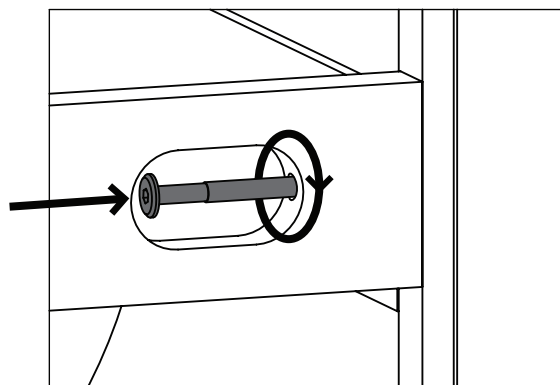

3. Slide the Plastic Crescent Washer over the exposed bolt, behind the head of the bolt. Tighten the bolt with the Allen Wrench provided.

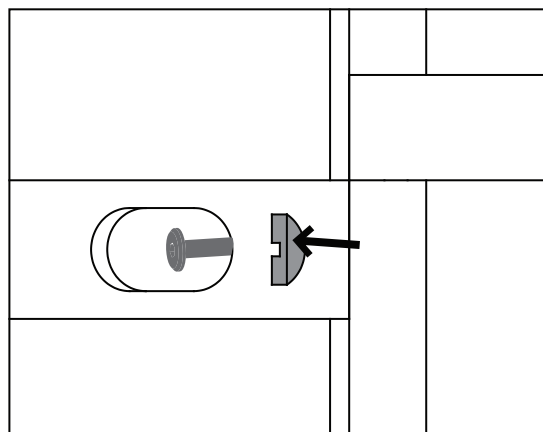

Install (1) bolt and (1) crescent washer at a time. Using the Hex Head Screwdriver, Tighten until it looks like the picture.

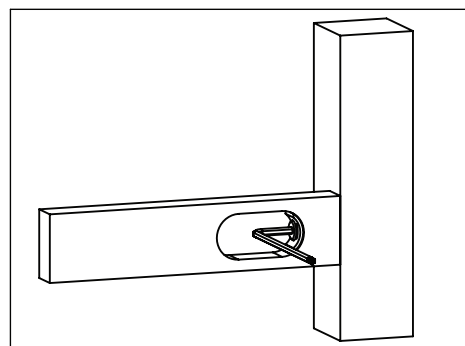
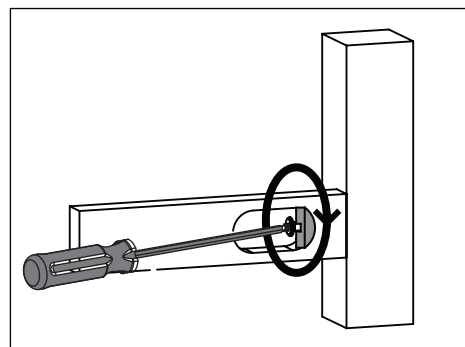

**Use the Hex Wrench Ensure all bolts are tightened.**

# STEP #1

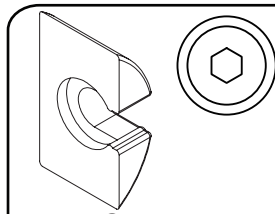

BB. Crescent Washer x3



DD.70mm Bolt x3

FF. WOOD DOWEL 30mm x6

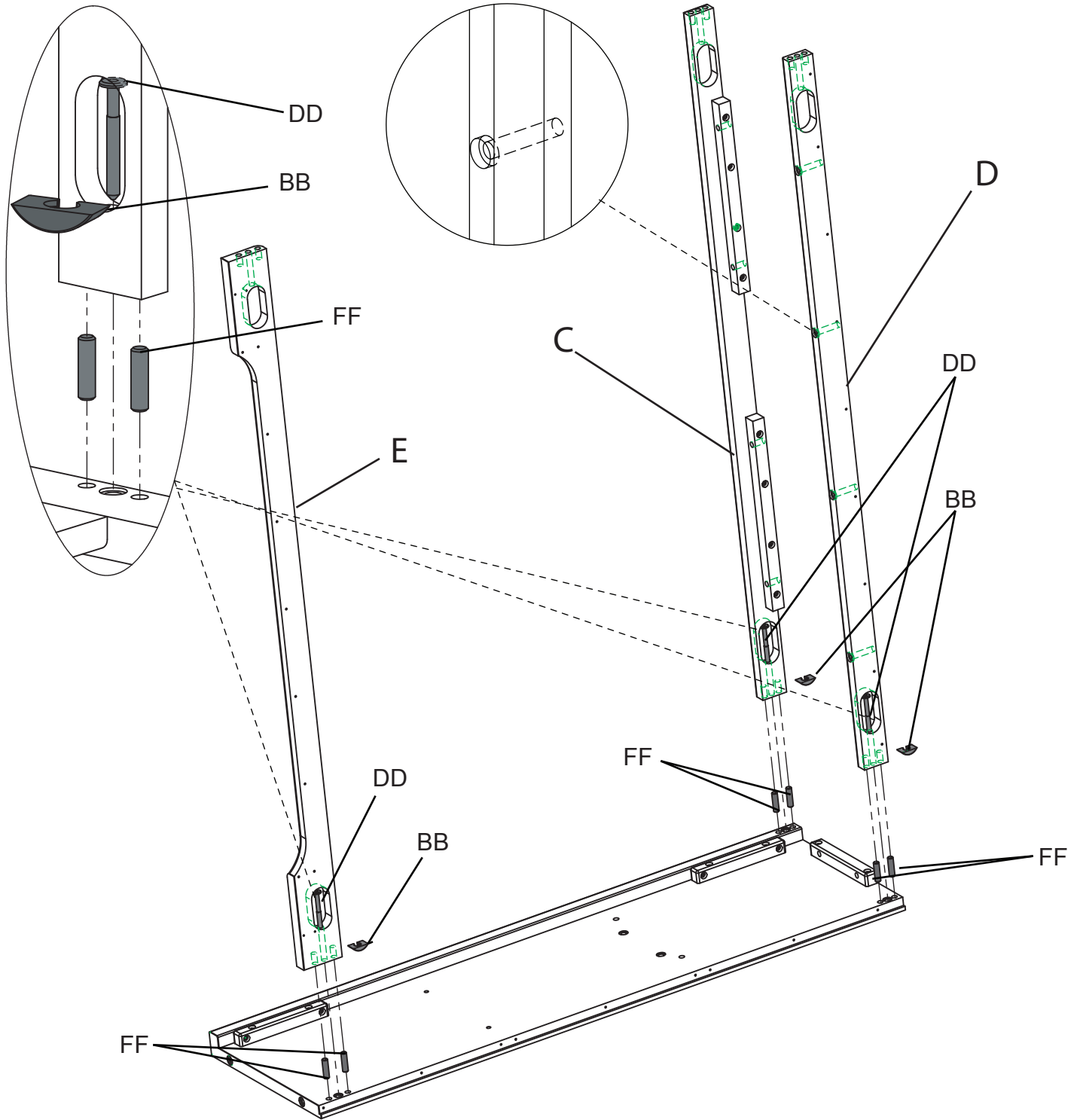

Attach the Bottom Back Rail (Part E), Front Rail (Part C) and Top Back Rail (Part D) to the Left Side (Part A). Install (6) Dowels (Part FF) as shown. Attach the rails to the Left Side using (3) 70mm Bolts (Part DD) and (3) Crescent Washers (Part BB). Install and tighten the Bolts following the directions on page 5.

## STEP #2

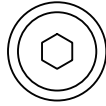

GG. 30mm Bolt x2

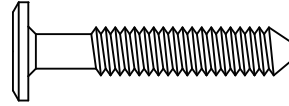

FF. WOOD DOWEL  
30mm x10

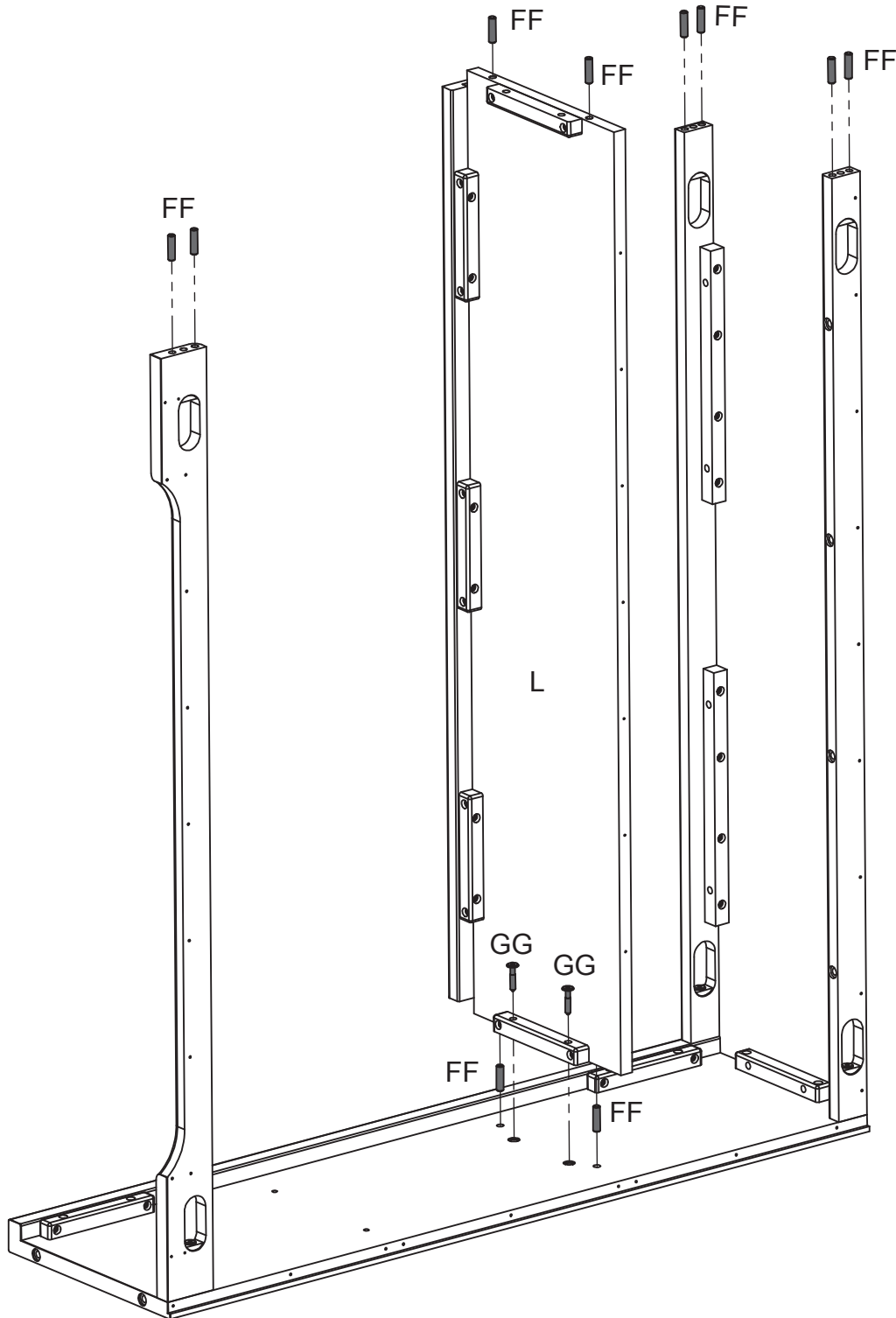

Attach the Fixed Shelf (Part L), to the Left Side using (2) Wood Dowels (Part FF) and (2) 30mm Bolts (Part GG) through the Fixed Shelf .  
Install and tighten the Bolts following the directions on page 5.  
Then install (8) Wood Dowels (Part FF) in ends of the rails and Shelf as shown.

# STEP #3

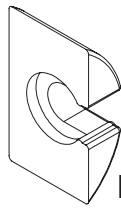

BB. Crescent Washer x3

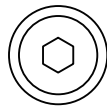

DD.70mm Bolt x3

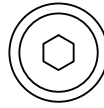

GG. 30mm Bolt x2

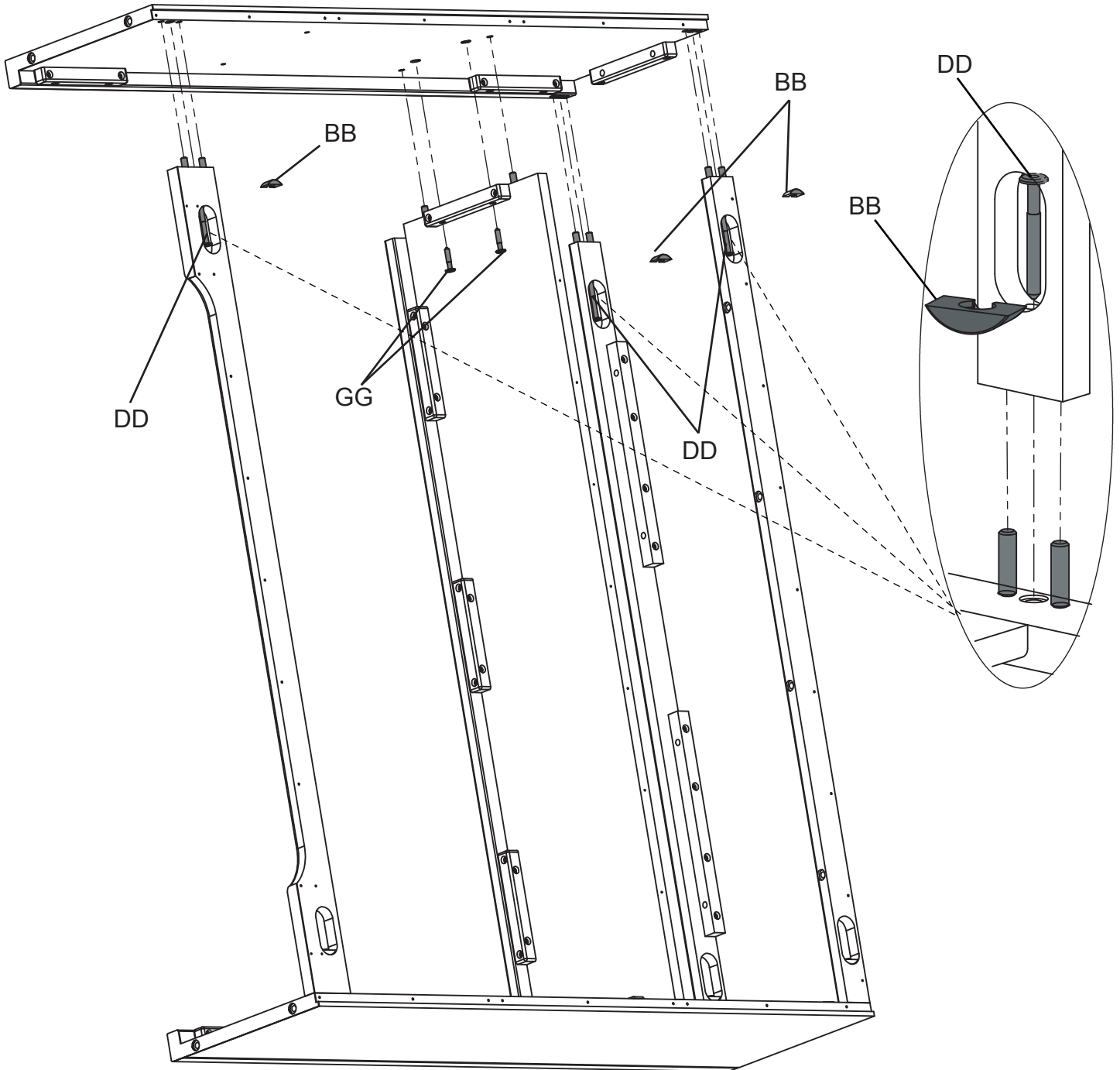

Carefully align all of the Dowels with the holes in the Right Side (Part B). Attach the Right Side using (3) 70mm Bolts (Part DD) and (3) Crescent Washers (Part BB). Install and tighten the Bolts following the directions on page 5. Then install (2) 30 Bolts (Part GG) through the Fixed Shelf. Tighten all bolts with Allen Wrench.



## STEP #4

GG. 30mm Bolt x8

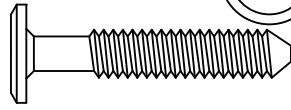

CC. 50mm Bolt x4

FF. WOOD

DOWEL 30mm x4

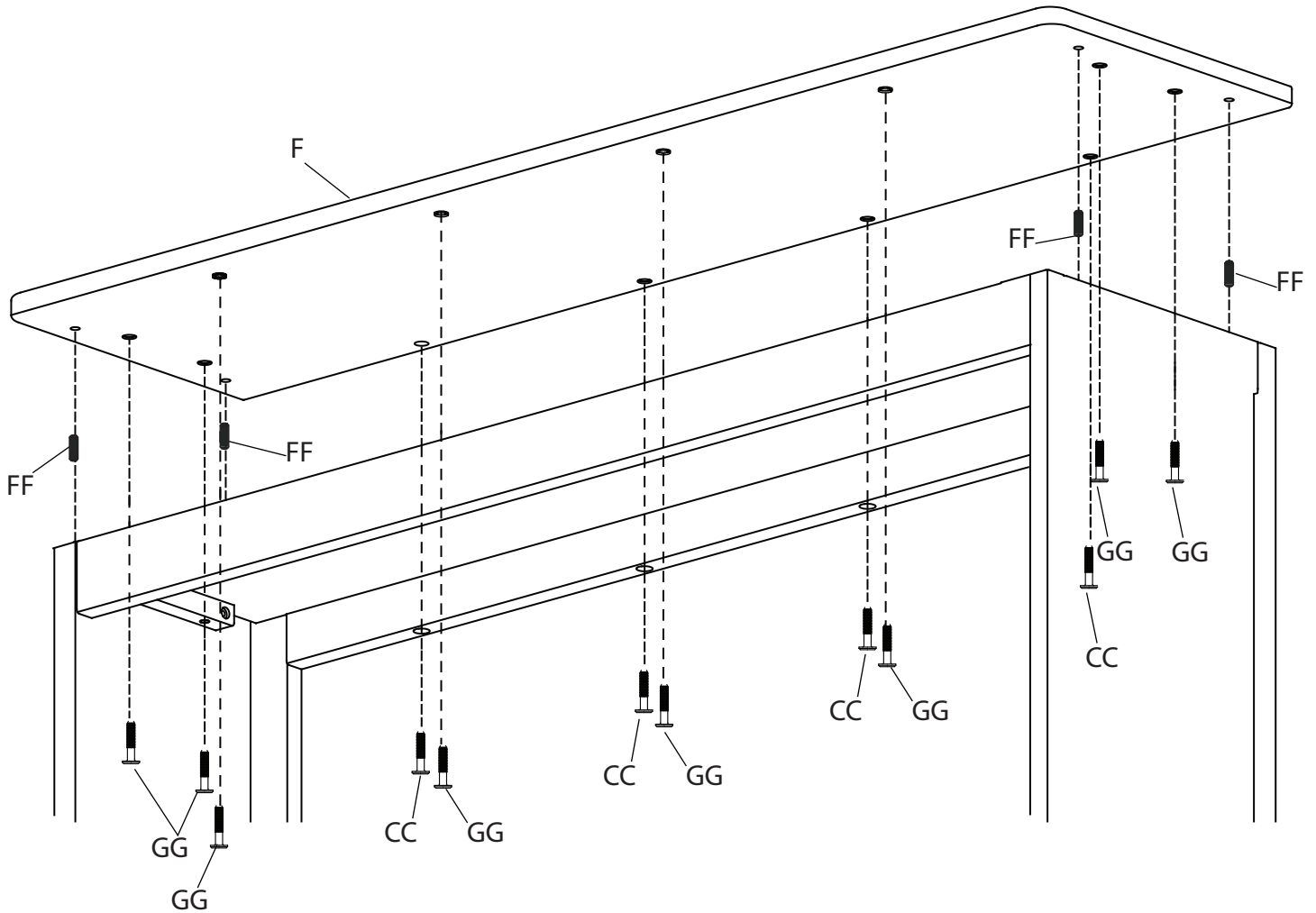

Attached the Top Panel (Part F) to the base of the case. Ensure (4) Dowels (Part FF) from the Side are aligned properly before installing any bolt. Install (4) 50mm Bolts (Part CC) through the Back Rails, and (4) 30mm Bolts (Part GG) through the Top Front Rail, then install (4) 30mm Bolts (Part GG) through the Sides. Tighten all bolts with the Allen Wrench.

# STEP #5

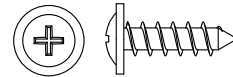

EE. Washer Head Screw x26

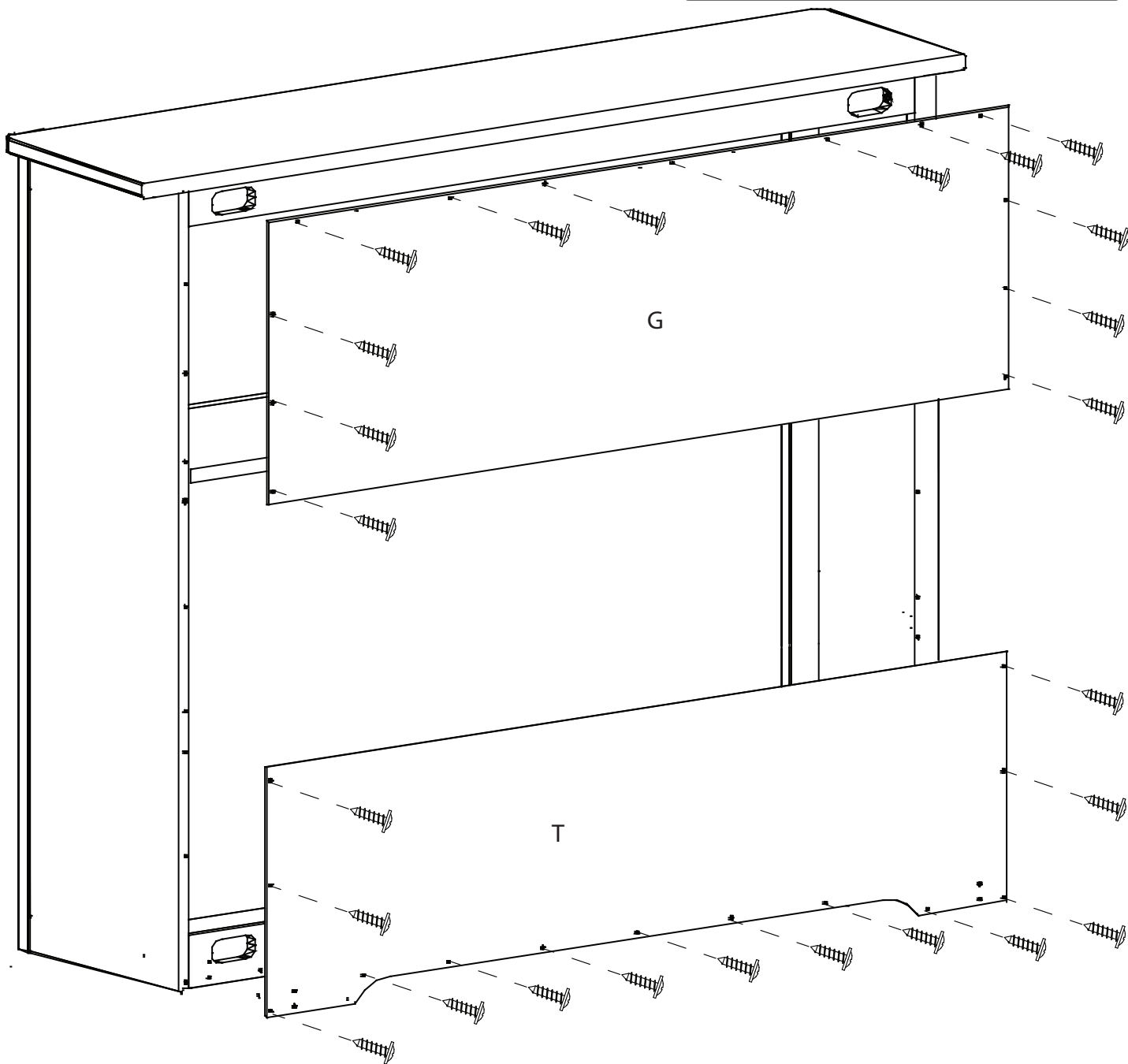

Attach Back Panel - Upper (Part G) and Back Panel - Lower (Part T) using (26) Washer Head Screws (Part EE). Tighten with a Phillips Screwdriver.

## STEP #6

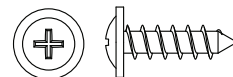

EE. Washer Head Screw x13

Insert The Joint Cover Rail (Part U) on the Back Panel - Lower, then insert the back Panel - Middle (Part H) into the slot of Joint Cover

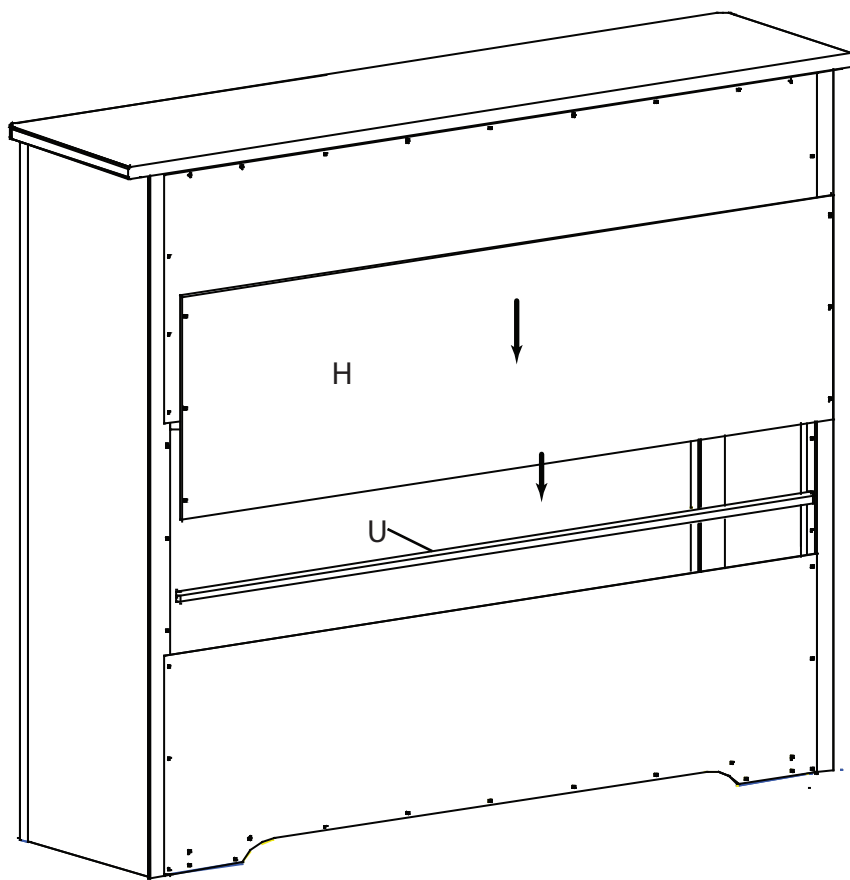

Using (13) Washer Head Screws (Part EE). Tighten with a Phillips Screwdriver.  
To use as a Hutch go to Step 12.  
To use as a Book Case go to Step 7.

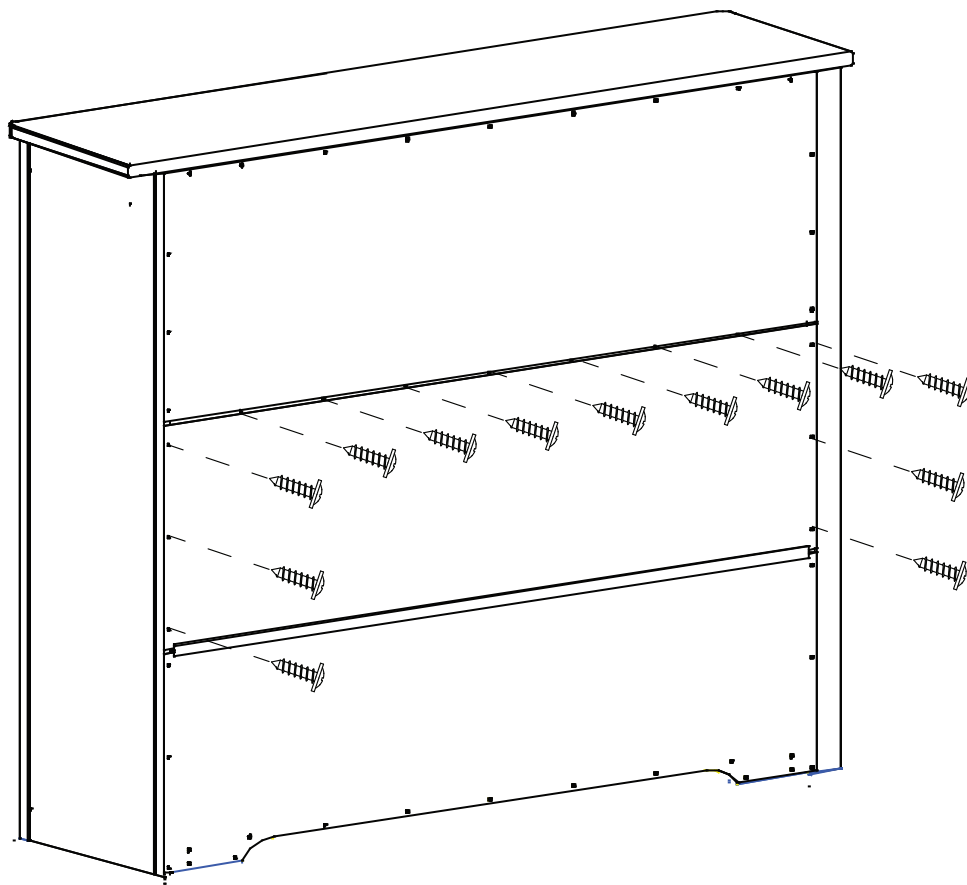

# STEP #7

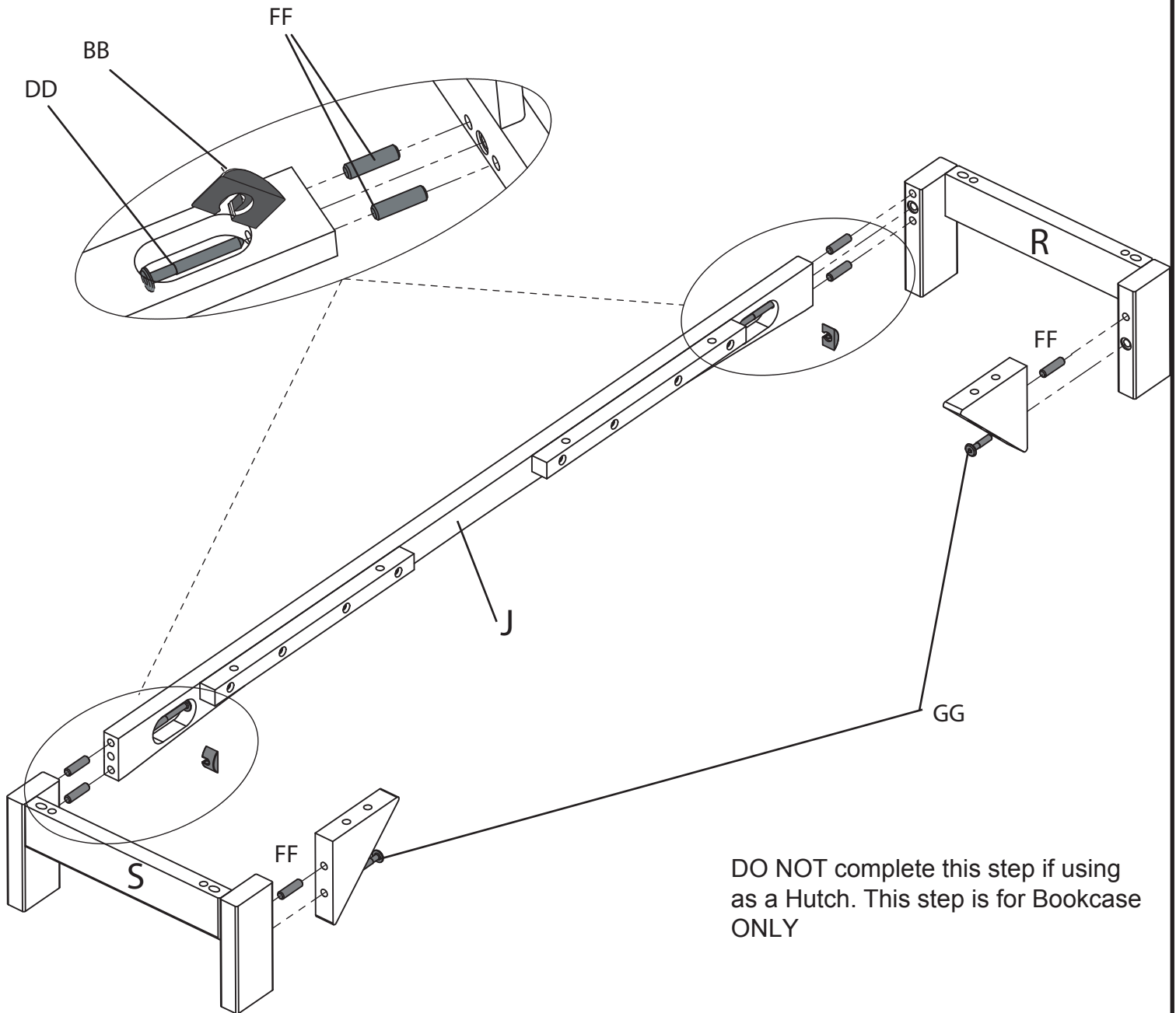
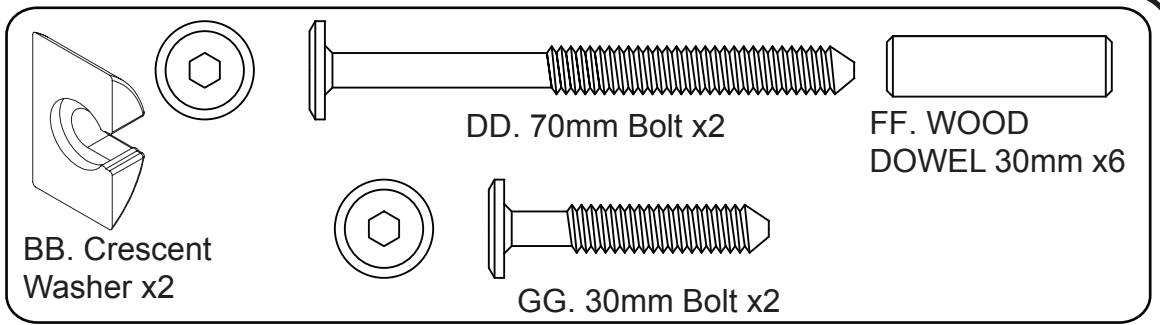

DO NOT complete this step if using as a Hutch. This step is for Bookcase ONLY

Attach the Base Front Rail (Part J) to the Book Shelf Left Side and Book Shelf Right Side (Parts R and S) using (4) Dowels (Part FF), (2) 70mm Bolts (Part DD) and (2) Crescent Washers (Part BB). Install and tighten the Bolts following the directions on page 5. Attach (2) Corner Braces (Part V) using (2) Dowels (Part FF) and (2) 30mm Bolts (Part GG), Tighten all bolts with Allen Wrench.

# STEP #8

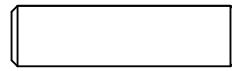

FF. WOOD  
DOWEL 30mm x2

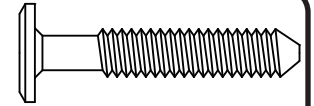
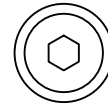

GG. 30mm Bolt x6

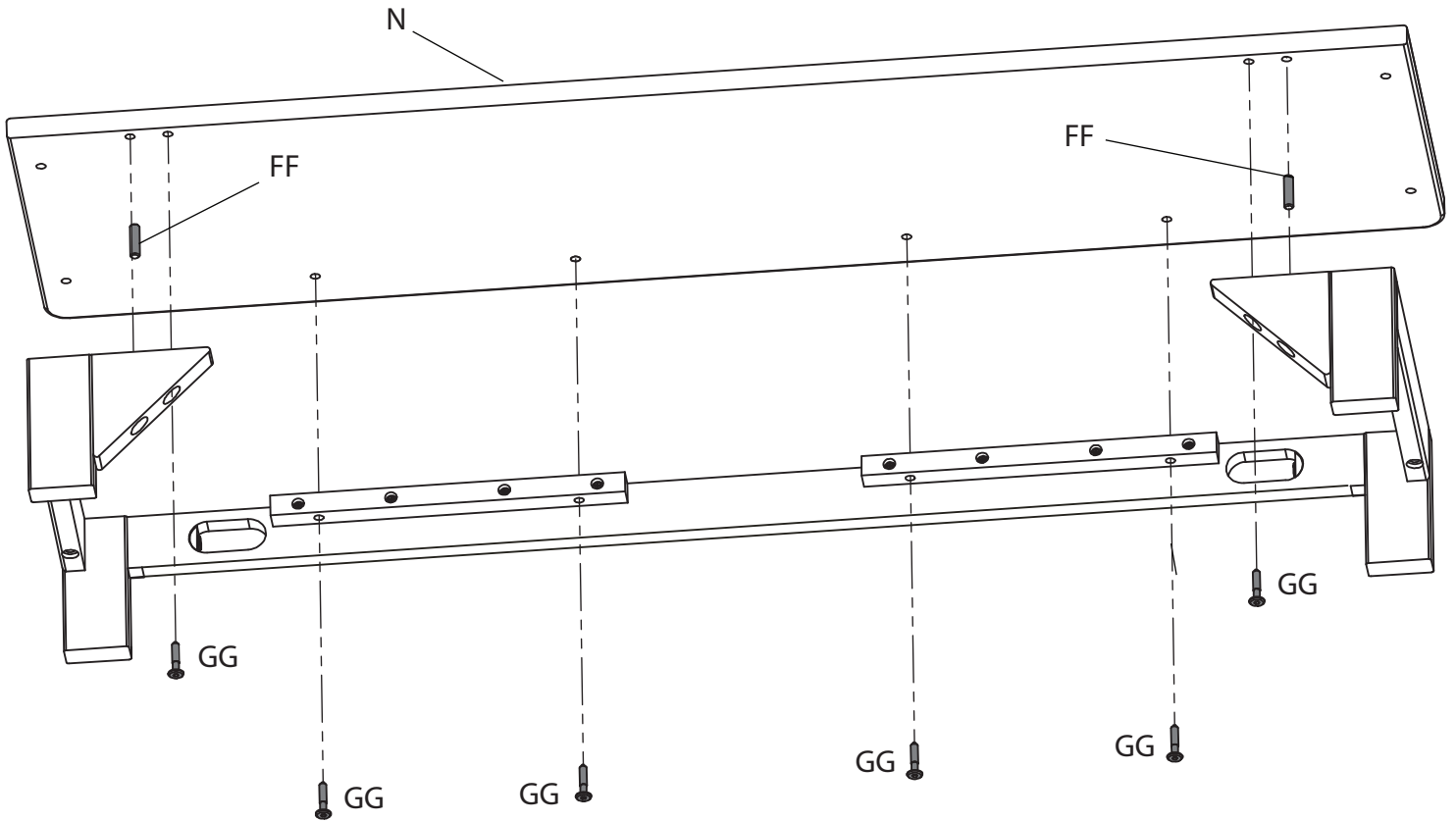

Attach the Book Shelf Bottom (Part N) to the base of the bookcase using (6) 30mm Bolts (Part GG) and (2) Dowels (Part FF). Tighten with the Allen Wrench.

## STEP #9

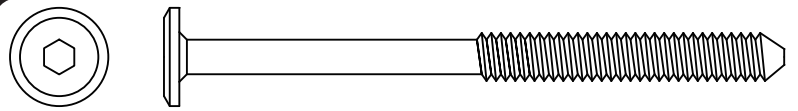

AA. 80mm Bolt x4

DO NOT complete this step if using as a Hutch.  
This step is for Bookcase ONLY.

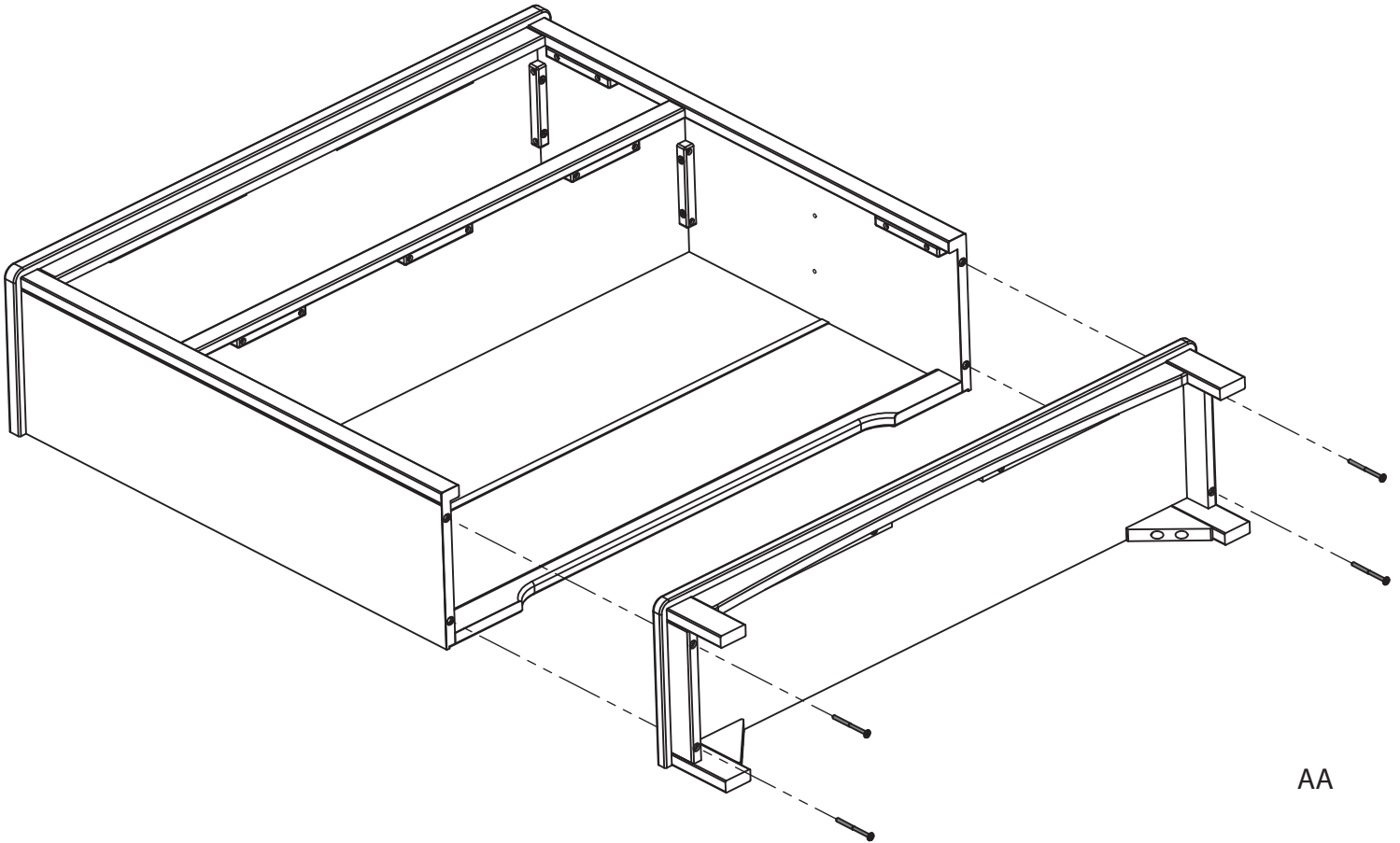

Install (4) 80mm Bolts (Part AA) through the Book Shelf Sides.  
Tighten all bolts with the Allen Wrench.

# STEP #10

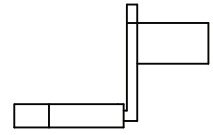

HH. Shelf Support x4

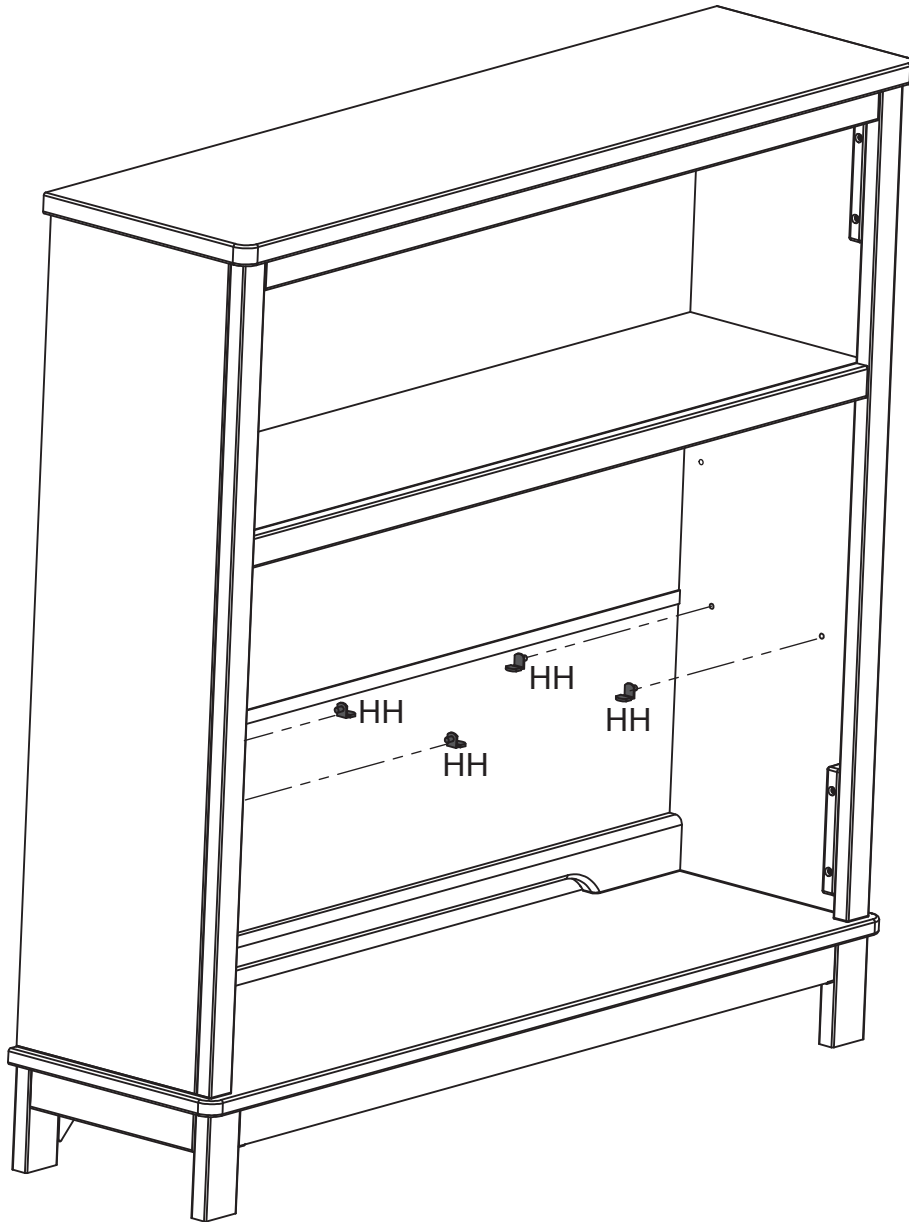

Insert (4) Shelf Supports (Part HH) in to the predrilled holes in the side.

## STEP #11

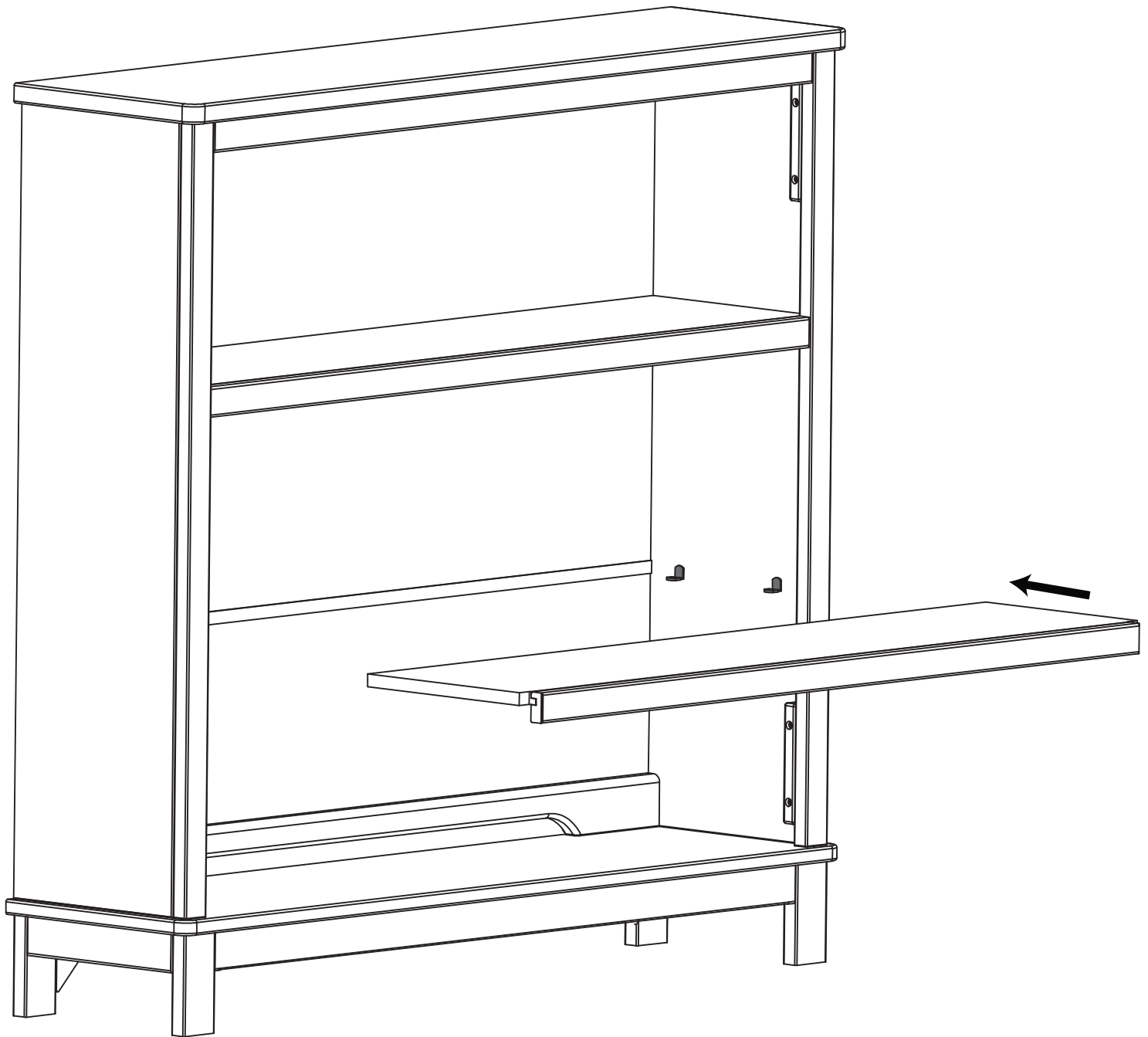

Insert the Removable Shelf (Part K) in the Hutch and place shelf on the supports.



BOOKCASE ASSEMBLY

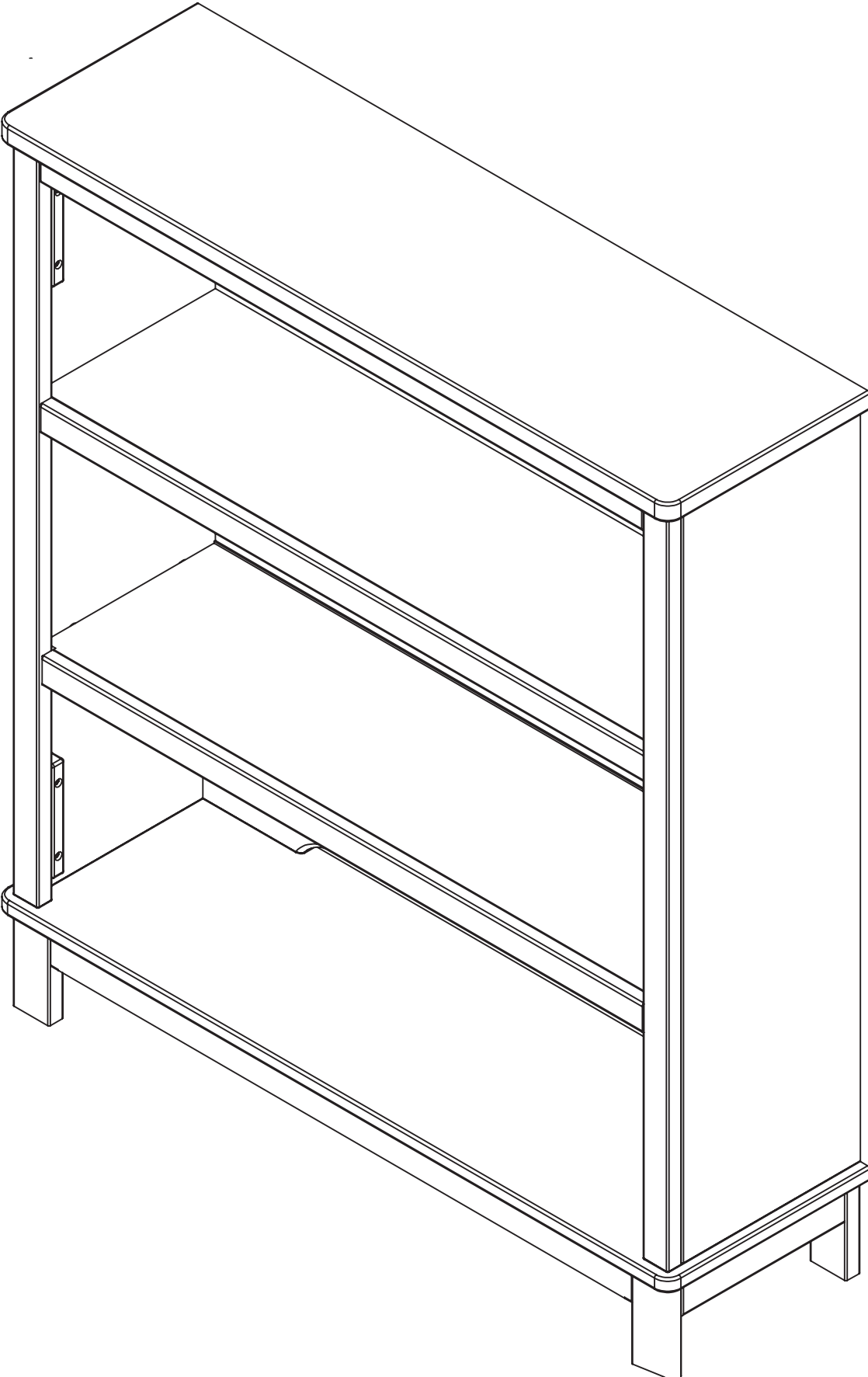

## STEP #12

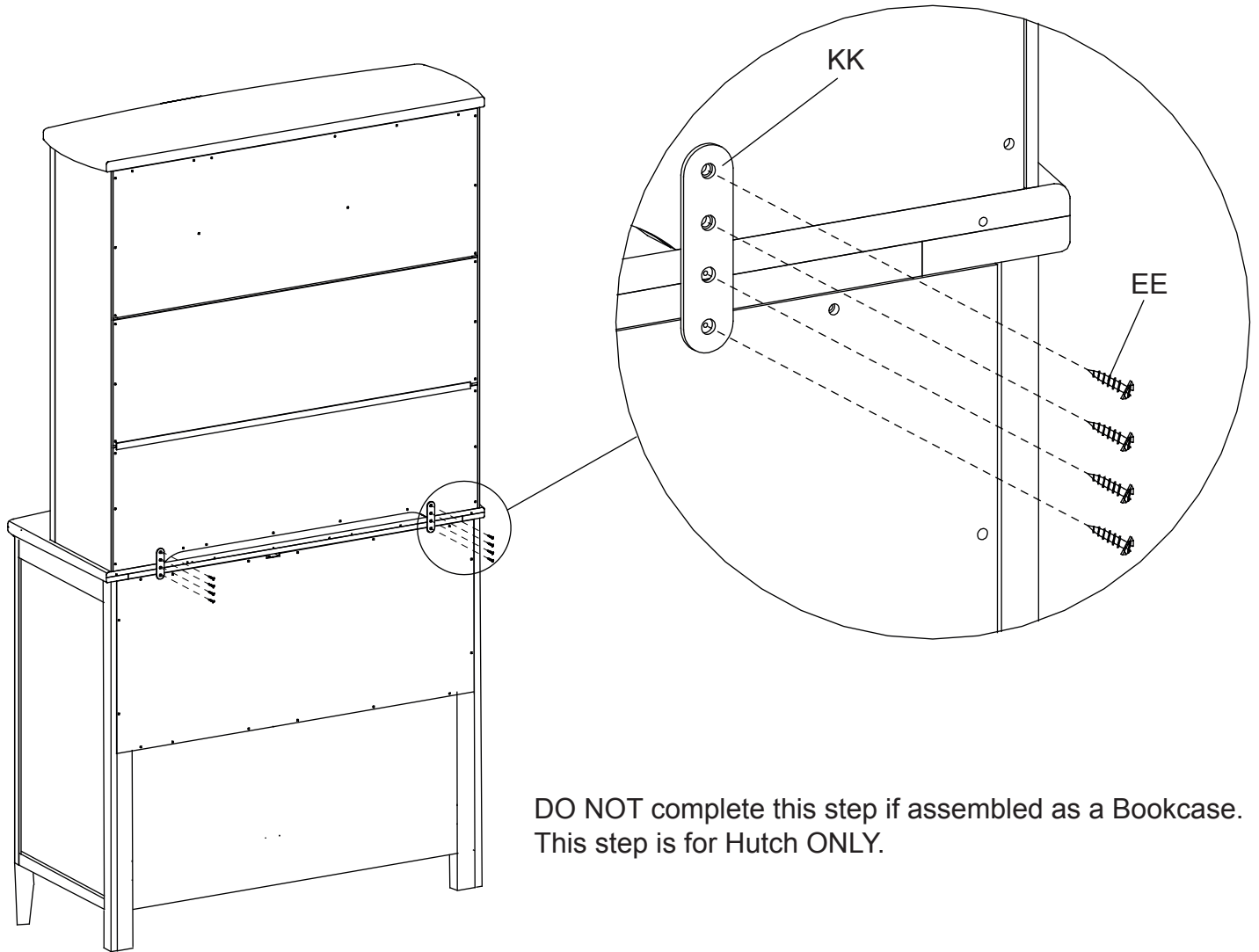
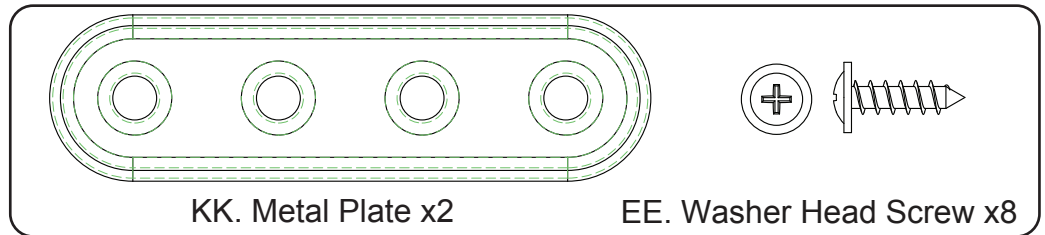

DO NOT complete this step if assembled as a Bookcase.  
This step is for Hutch ONLY.

Place the Hutch onto the Dresser Base Unit NOT Included - See Retail Store or Contact Delta Children's Products. Install (2) Metal Plates (Part KK) to back of the Hutch, using (4) Screws (Part EE) into the pre-drilled holes. Install (4) Screws (Part EE) into the back of Double Dresser into the pre-drilled holes.  
Tighten with a Phillips Screwdriver.

# STEP #13

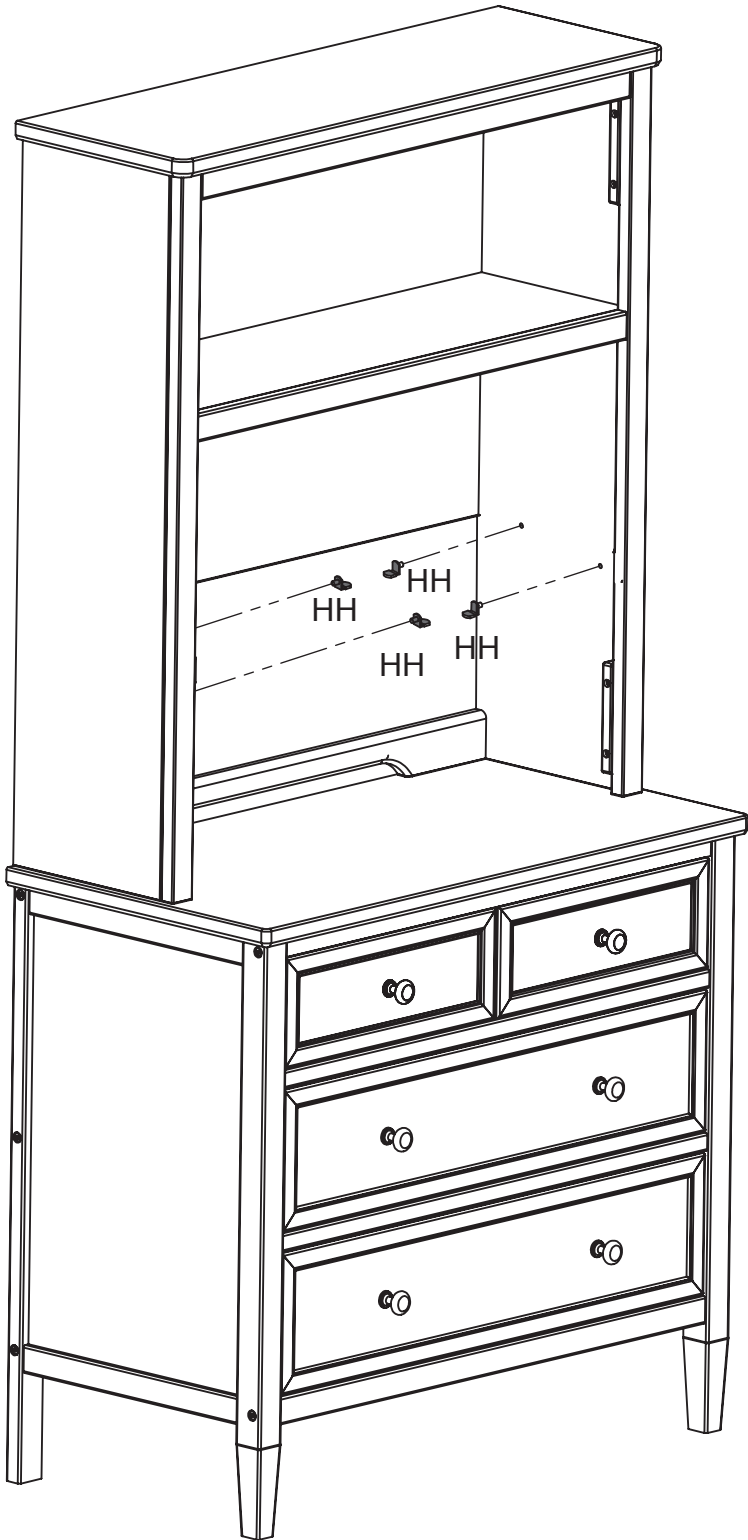
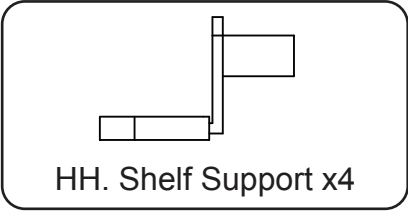

Insert (4) Shelf Supports (Part HH) in to the predrilled holes in the side.

## STEP #14

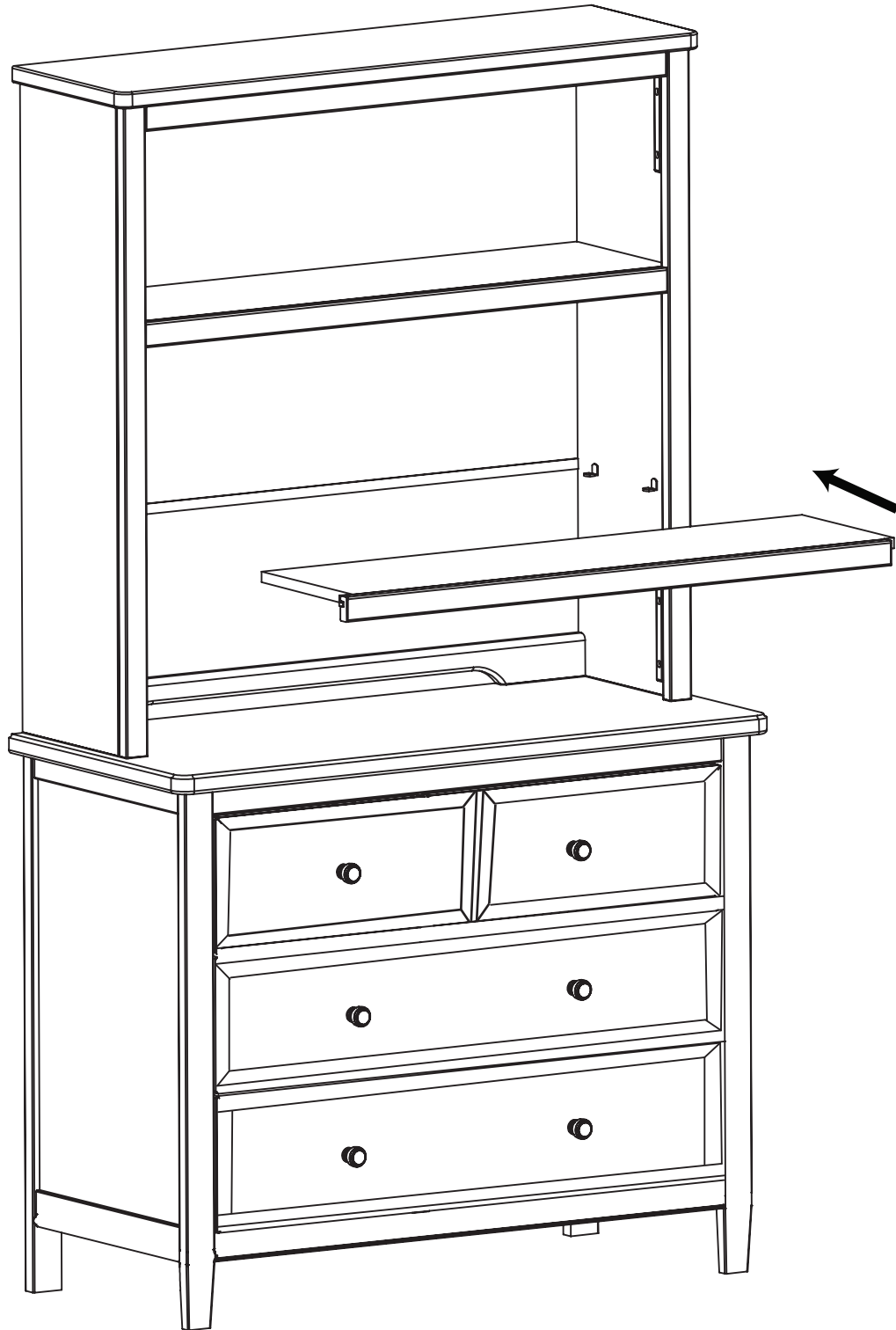

Insert the Removable Shelf (Part K) in the Hutch and place shelf on the supports.  
DO NOT use the Removable Shelf when using base unit as a changing surface.

# HUTCH ASSEMBLY

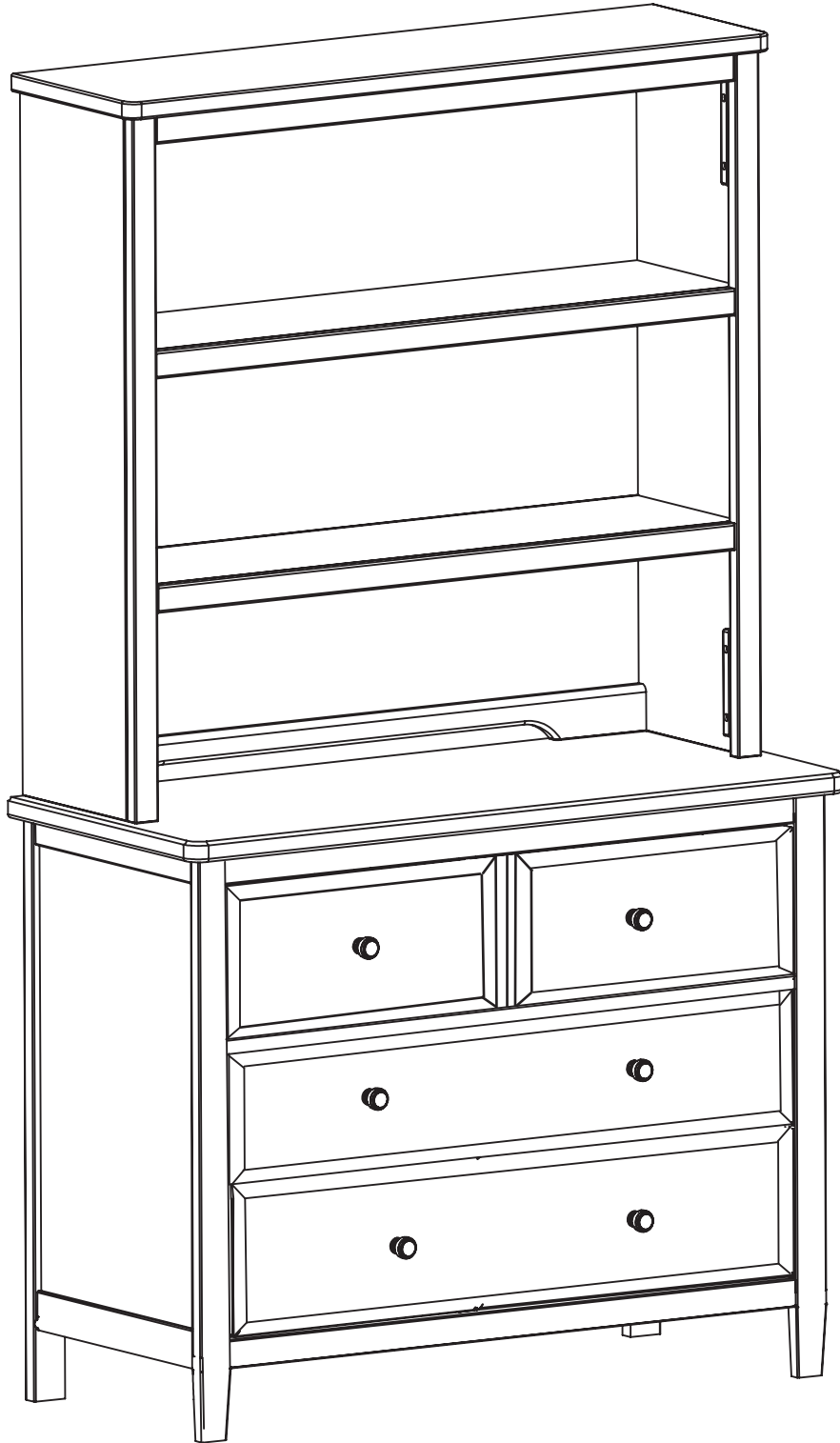

Dresser Base Unit NOT Included - See Retail Store or Contact Delta Children's Products



Consumer Care:  
[www.DeltaChildren.com](http://www.DeltaChildren.com)  
Delta Children's Products  
114 West 26th Street  
New York, NY 10001  
Tele.212-645-9033

**Warranty:** This Delta product is warranted to be free from defects for a period of 90 days from the date of purchase under normal use. This warranty extends only to the original retail purchaser and is valid only when supplied with proof of purchase, or if received as a gift, when the registration is on file with Delta.

To register your product for important safety alerts and updates to your product please visit [www.deltachildren.com](http://www.deltachildren.com)

Please do not return this item to the store before contacting us about missing parts or with any questions.

To report a problem, please log on to [www.deltachildren.com](http://www.deltachildren.com) and click the Consumer Care Tab, or contact us by phone at (212) 645-9033.

In the event that you need to contact our customer service department please have the Style Number and Lot Number available. Use the space below to make note of those numbers. They can be found on the label on the *Back Panel*.

STYLE No: **76300**

COLOR

REV

FTY

Lot No. : \_\_\_\_\_

MFG DATE: \_\_\_\_\_

Date of Purchase: \_\_\_\_\_ (you should also keep your receipt)