

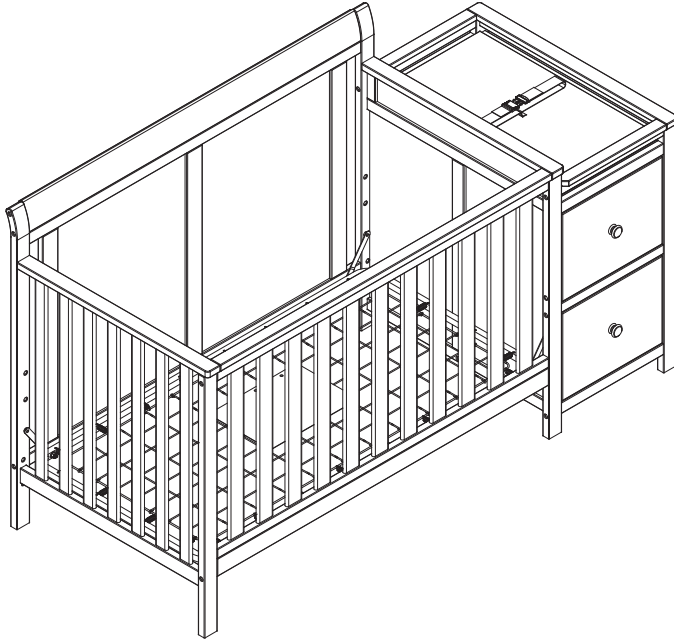

Read all instructions before assembly and use.
KEEP INSTRUCTIONS FOR FUTURE USE.

ADULT ASSEMBLY REQUIRED
Due to the presence of small parts during assembly, keep out of reach of children until assembly is complete.

Crib N Changer



Need Help?

Please visit www.DeltaChildren.com/assembly-videos to watch our easy and effective assembly videos

Consumer Care:
www.DeltaChildren.com

Delta Children's Products
114 West 26th Street
New York, NY 10001
Tele.212-645-9033

**This product is not intended for institutional or commercial use.
Este producto no esta hecho para uso institucional o comercial.**

Style #: _____
Lot: _____
Date: _____



When contacting Delta Consumer Care please reference the above information. Before contacting Delta Consumer Care please ensure that the information above matches the information found on the label on the Crib End bottom rail, please reference the information found on the product when contacting Delta Consumer Care.

To register your product for important safety alerts and updates to your product please visit www.DeltaChildren.com and click on Product Registration.

CAUTION:

ANY MATTRESS USED IN THIS CRIB SHALL BE AT LEAST 27 1/4 BY 51 5/8 IN. WITH A THICKNESS NOT EXCEEDING 6 IN.

WARNING:

*Infants can suffocate on soft bedding. Never add a pillow or comforter. Never place additional padding under an infant.

*Failure to follow these warnings and the assembly instructions could result in serious injury or death. DO NOT use this crib if you cannot exactly follow the accompanying instructions.

*To reduce the risk of SIDS, pediatricians recommend healthy infants be placed on their backs to sleep, unless otherwise advised by your physician.

***Strangulation Hazard:** STRINGS CAN CAUSE STRANGULATION! Do not place items with a string around a child's neck, such as hood strings or pacifier cords. Do not suspend strings over a crib or attach strings to toys.

***Strangulation Hazard:** To help prevent strangulation tighten all fasteners. A child can trap parts of the body or clothing on loose fasteners.

***Strangulation Hazard:** Do not place crib near window or patio door where cords from blinds or drapes may strangle a child.

***Fall Hazard:** When child is able to pull to a standing position, set mattress to lowest position and remove bumper pads, large toys and other objects that could serve as steps for climbing out. This crib has an adjustable mattress support. For the convenience of the parent when the baby is very small, the mattress support may be used in the highest position. Important: with the mattress support and mattress in the highest position, be absolutely sure that the top of the front crib side is at least 3 inches higher than the top surface of the mattress. If it is not, lower the mattress support and the mattress to the next highest position.

***Fall Hazard:** Stop using crib when child begins to climb out or reaches a height of 35in. (89cm), whichever occurs first. The child should be placed in a youth or regular bed.

*Check this product for damaged hardware, loose joints, loose bolts or other fasteners, missing parts, or sharp edges before and after assembly and frequently during use. Securely tighten loose bolts and other fasteners. Do not use crib if any parts are missing, damaged or broken. Contact Delta Children's Products for replacement parts and instructional literature if needed. Do not substitute parts.

*Follow warnings on all products in a crib.

*If refinishing, use a non-toxic finish specified for children's products.

***Never** use plastic shipping bags or other plastic film as mattress covers because they can cause suffocation.

*Infants can suffocate in gaps between crib sides and a mattress that is too small.

*Ensure a safe environment for the child by checking regularly, before placing the child in the crib, that every component is properly and securely in place.

*To avoid head injury, do not allow any child to play underneath the crib.

***Never** add an accessory such as a bassinet or changing table that extends over the sleeping area.

***In Canada Only** - Use a crib mattress that is no thicker than 15 cm and is of such a size that, when it is pushed firmly against any side of the crib, it does not leave a gap of more than 3 cm between the mattress and any part of the sides of the crib. Do not use this crib for a child who can climb out of it or who is taller than 90 cm.

TODDLER BED

⚠️ WARNING

INFANTS HAVE DIED IN TODDLER BEDS FROM ENTRAPMENT.

Openings in and between toddler bed parts can entrap head and neck of a small child.
NEVER use toddler bed with children younger than 15 months.
ALWAYS follow assembly instructions.
The maximum user weight is 50lbs (22.7kg)

⚠️ WARNING

STRANGULATION HAZARD

NEVER place bed near windows where cords from blinds or drapes may strangle a child.
NEVER suspend strings over a bed.
NEVER place items with a string, cord, or ribbon, such as hood strings or pacifier cords, around a child's neck. These items may catch on bed parts.

⚠️ CAUTION

ENTRAPMENT HAZARD

To avoid dangerous gaps, any mattress used in this bed shall be a full-size crib mattress at least 51 5/8 in (1310mm) in length, 27 1/4 in (690mm) in width and a max thickness of 6 in (150 mm).

⚠️ WARNING: Changing Table

⚠️ WARNING

FALL HAZARD - to prevent death or serious injury, always keep child within arm's reach. Read all instructions before use of the changing table.
KEEP THESE INSTRUCTIONS IN A SAFE PLACE FOR FUTURE USE.
Inspect the changing table periodically. **Do not** use the changing table if it is damaged or broken. Contact Delta Children's Products with any questions.
Tighten all loose screws and bolts before each use.
The maximum recommended weight of the child is 30lbs for the changing table.
Use only the pad provided by Delta Children's Products.
Always secure the pad to the changing surface by inserting the strap through the hole in the middle of the pad. See Instructions.
NEVER use crib without Changing Table attached

NOTES ON ASSEMBLY:

- During the assembly process whenever using screws or bolts, check each by placing the screw/bolt on the diagram of the item which is drawn actual size and design. Be sure to use the proper size and shape specified in the instructions.
- To assemble this unit you may be required to place the unit on it's side and face. It is strongly recommended that assembly is done on a soft, non-abrasive surface (such as the foam packing wrap) to avoid damaging the finish.

NOTES ON USE:

Keep children and others safe by following these simple rules:

- **Do not** allow any child to play on furniture
- **Do not** allow climbing on any piece of furniture.
- **Do not** allow hanging from any piece of furniture.
- Always monitor your child's activity when in the nursery.

NOTES ON CARE AND MAINTENANCE:

- **Do not** scratch or chip the finish.
- Inspect the product periodically, contact Delta Children's Products for replacement parts or questions.
- **Do not** store the product or any parts in extreme temperatures and conditions such as a hot attic or a damp, cold basement. These extremes can cause a loss of structural integrity.
- To preserve the luster of the high quality finish on your product, it is recommended to place a doily or felt pad under any items you place on the finish.
- Clean with a damp cloth, then a dry cloth to preserve the original luster and beauty of this fine finish.
- Do not** use abrasive chemicals.
- Do not** spray cleaners directly onto furniture.
- Lift slightly when moving on carpeting to prevent leg breakage.
- Use of a vaporizer near furniture will cause wood to swell and finish to peel.

PARTS: MAKE SURE THAT ALL PRE-ASSEMBLED PARTS ARE TIGHT.

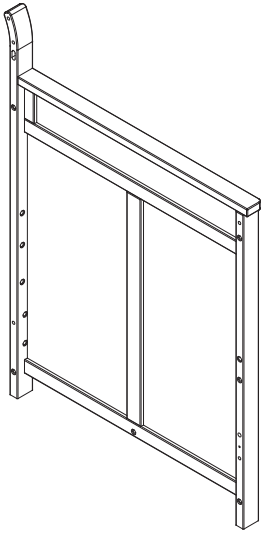

A. Common Side x 1
Part # 25281

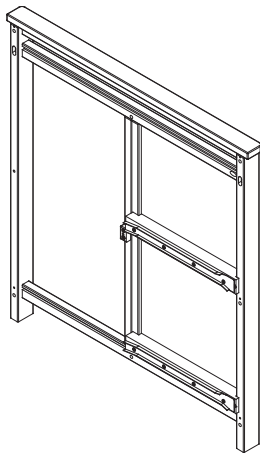

B. Changer End x 1
Part # 24799

C. Changer Top
Front Rail x 1
Part # 24804

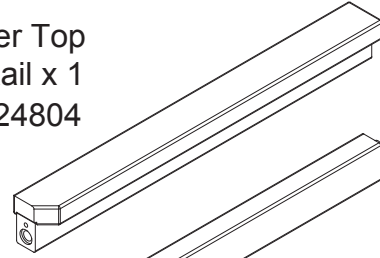

D. Changer Top Center Rail x 2
Part # 24807

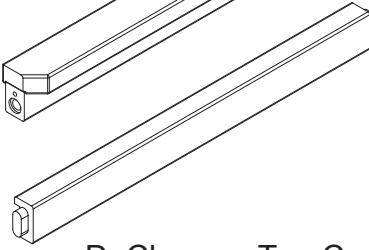
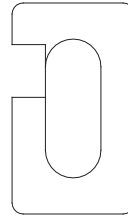

E. Changer Middle
Front Rail x 1
Part # 24805

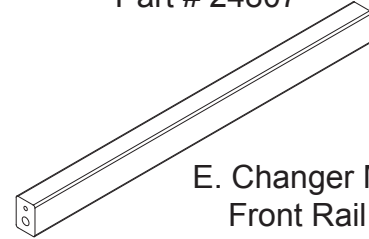
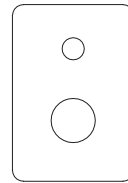

F. Changer Bottom
Front Rail x 1
Part # 24806

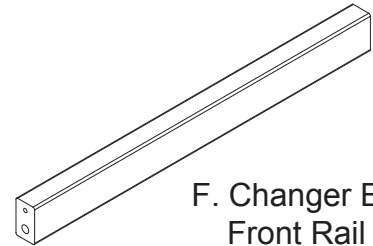
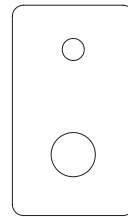

G. Changer Top
Back Rail x 1
Part # 24809

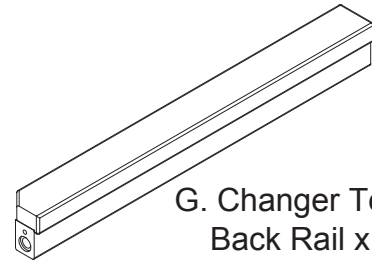

H. Changer Bottom
Back Rail x 1
Part # 24810

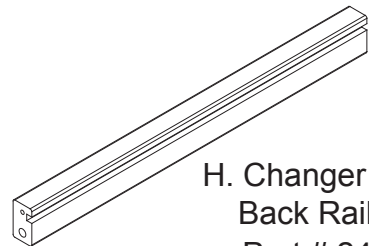
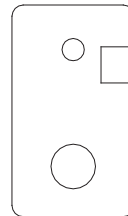

J. Changer Bottom
Center Rail x 1
Part # 24808

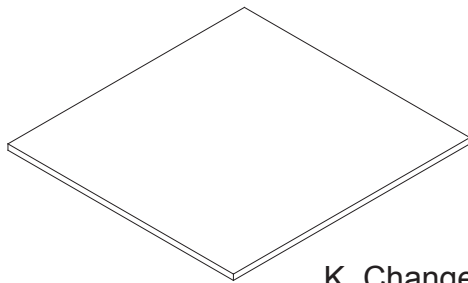
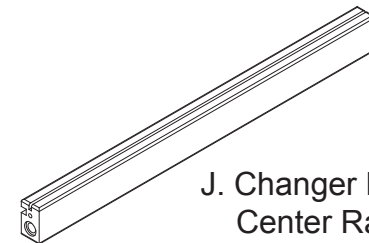
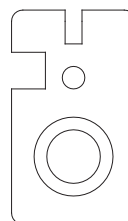

K. Changer Removable
Shelf x 1
Part # 24802

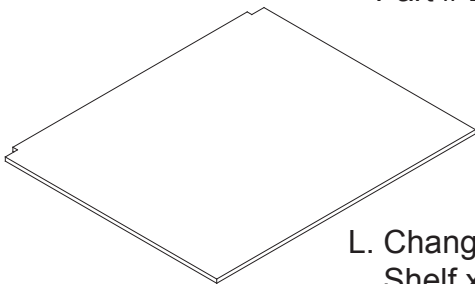

L. Changer Fixed
Shelf x 1
Part # 24801

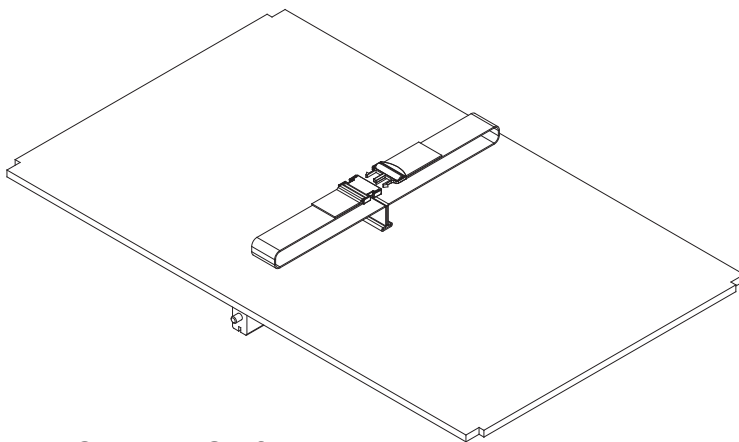

M. Changer Surface
with Strap x 1
Part # 24803

PARTS: MAKE SURE THAT ALL PRE-ASSEMBLED PARTS ARE TIGHT.

P. Changer Center
Panel x 1
Part # 24807

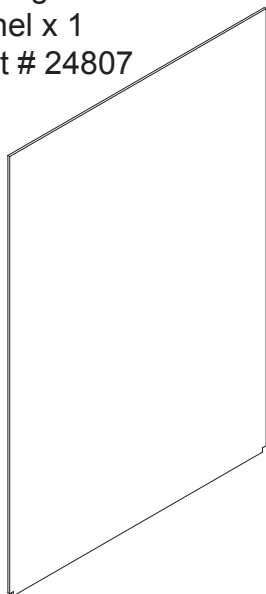

N. Changer Pad x 1
Part # 24816

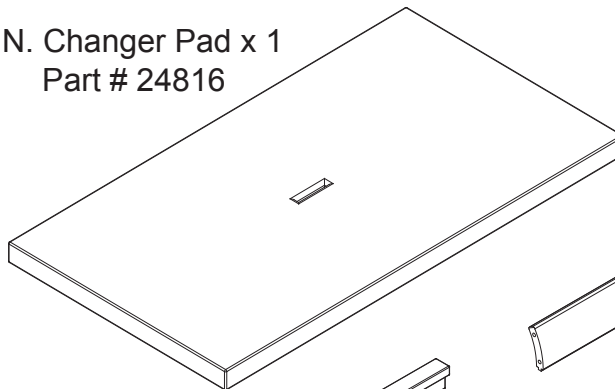

S. Crib Top Back Rail x 1
Part # 24795

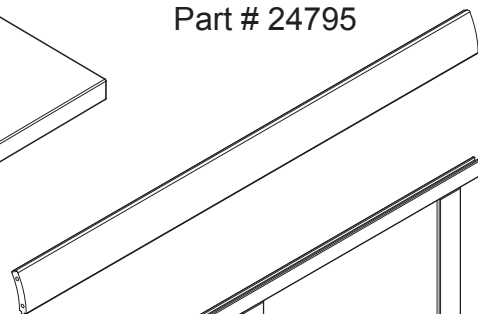

T. Crib Back Rail x 1
Part # 24794

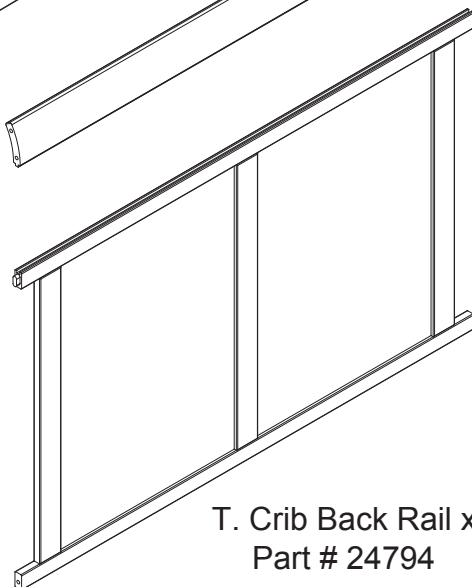

U. Crib Front Rail x 1
Part # 25280

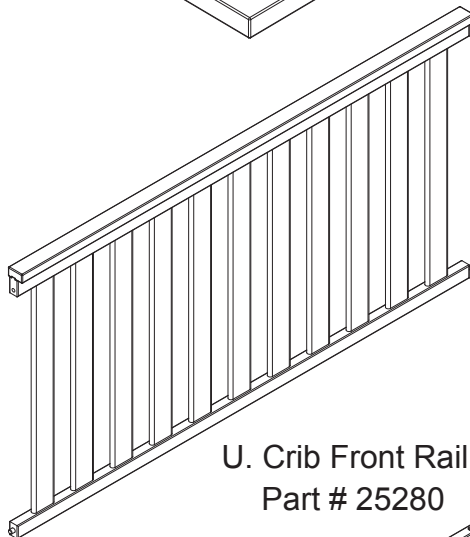

V. Stabilizer Bar x 1
Part # 24797

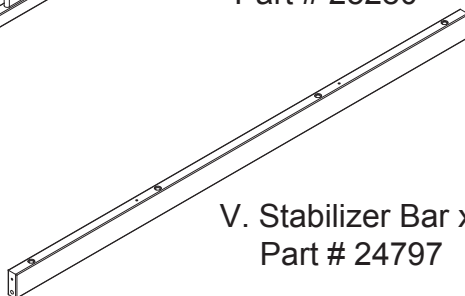

R. Left Crib Side x 1
Part # 25279

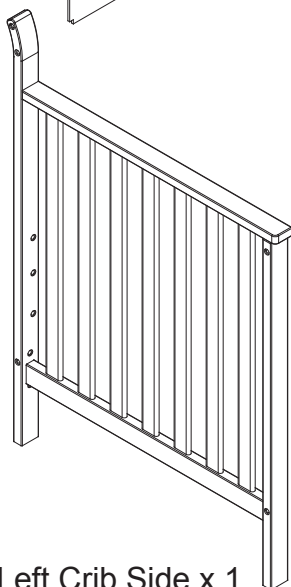

W. Drawer Front x 2
Part # 24811

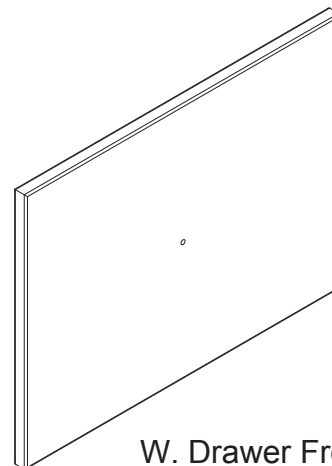

Z. Drawer Right Side x 2
Part # 24813

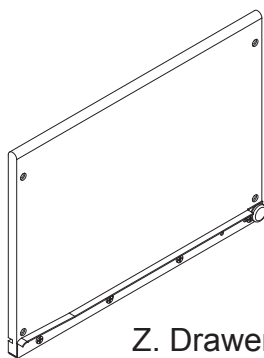

Y. Drawer Left Side x 2
Part # 24812

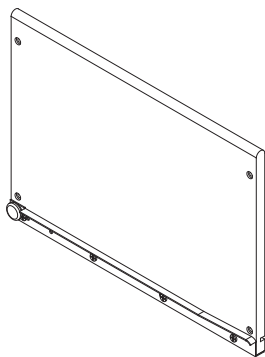

X. Drawer Back x 2
Part # 24814

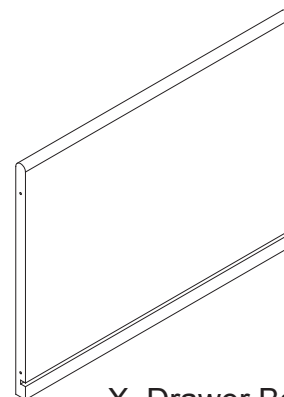

AA. Drawer Bottom Panel x 2
Part # 24815

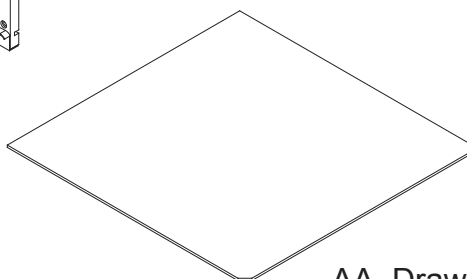

PARTS: HARDWARE KIT PART #24818-988 FOR COLOR 616 . SEE FRONT COVER.

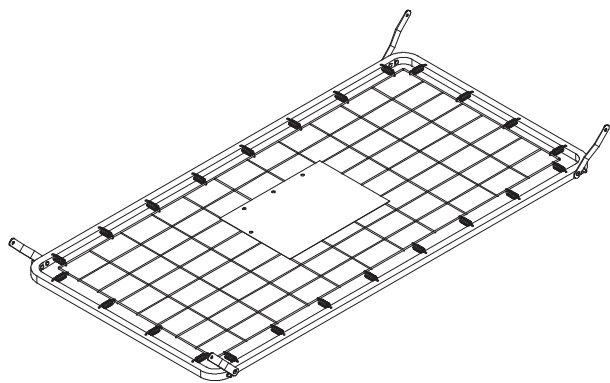

BB. Mattress Support x 1
Part # 24242

Pouch attached to mattress support - keep instructions in this pouch after assembly. Warnings related to the safe use of this crib are printed on the pouch.



No drills necessary.
Do not use power screwdriver.

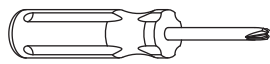

Phillips Screwdriver
(not supplied)



Flat Head Screwdriver
(not supplied)

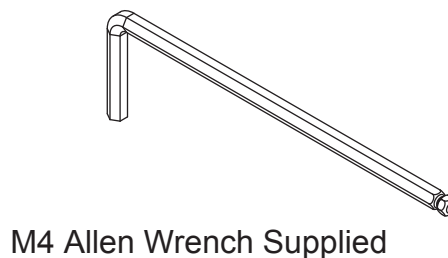
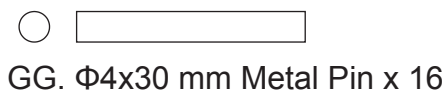
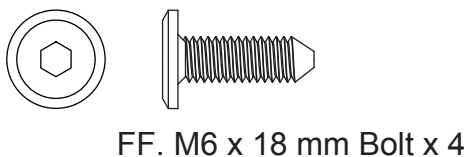
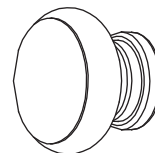
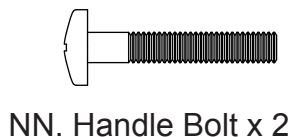
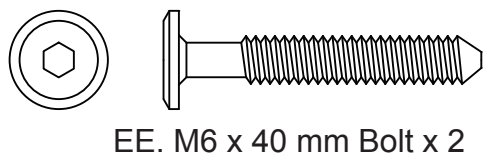
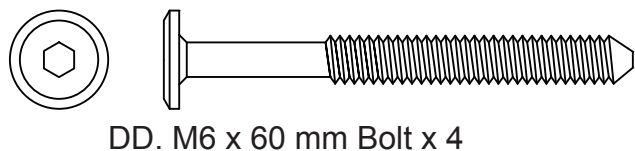
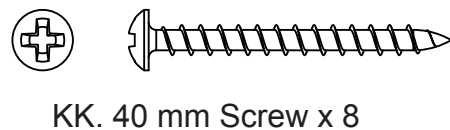
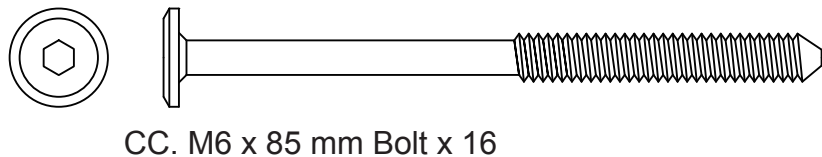
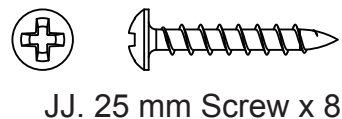

Section 1: Changing Table Assembly

Step 1

Parts and tools required to complete step.

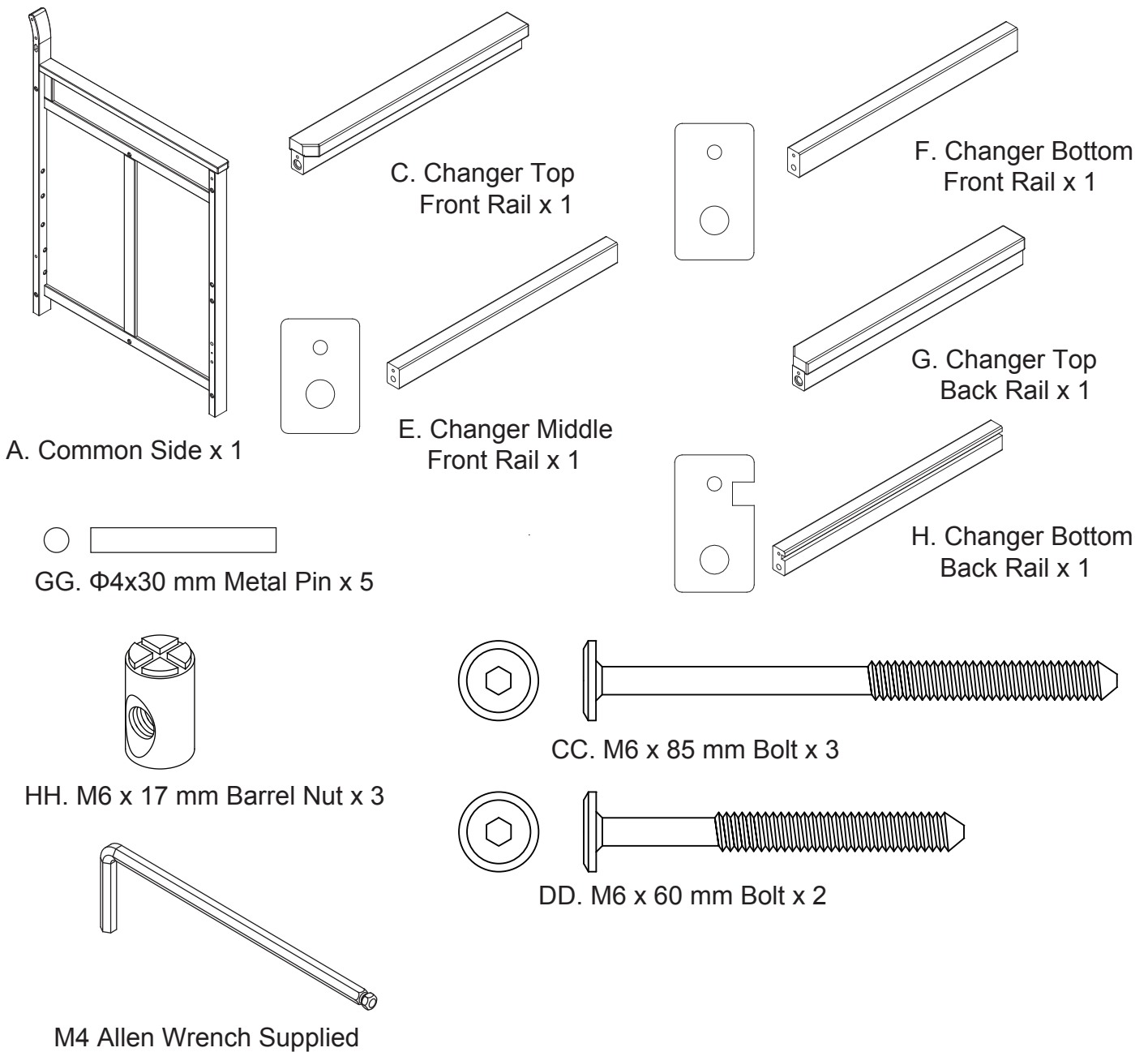

Attach (1) Changer Top Front Rail (Part C), (1) Changer Top Back Rail (Part G), (1) Changer Middle Front Rail (Part E), (1) Changer Bottom Front Rail (Part F) and (1) Changer Bottom Back Rail (Part H) to the Common Side (Part A) using (5) Φ 4x30 mm Metal Pins (Part GG), (2) M6 x 60 mm Bolt (Part DD), (3) M6 x 85 mm Bolt (Part CC) and (3) M6 x 17 mm Barrel Nuts (Part HH). Tighten with the M4 Allen Wrench. Use the Flat Head Screwdriver to hold the Barrel Nut in the proper alignment.

NOTE: ILLUSTRATION ON NEXT PAGE.

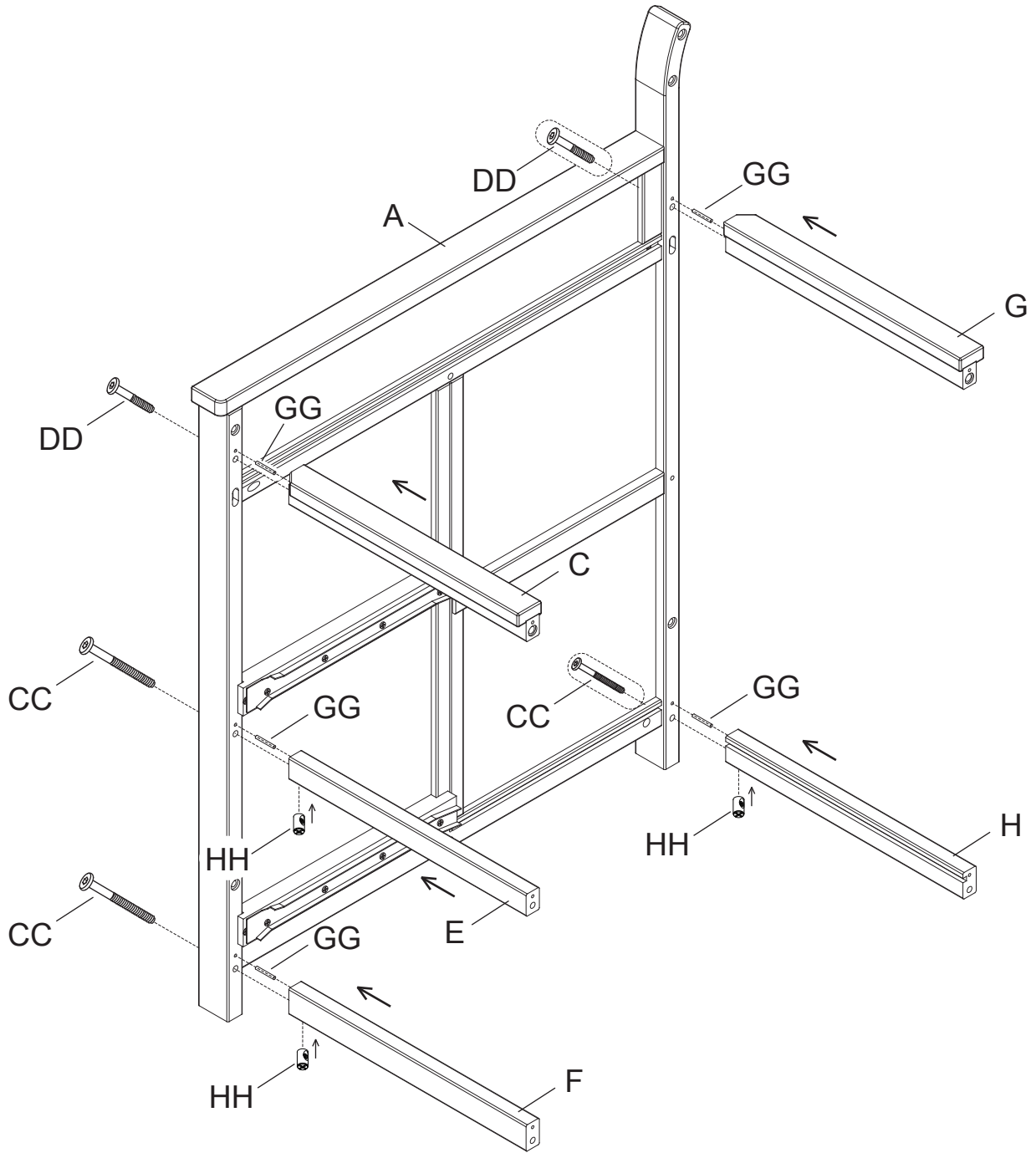

Section 1: Changing Table Assembly

Step 2

Parts and tools required to complete step.

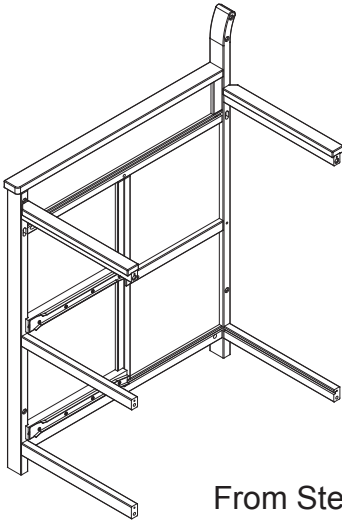

From Step 1

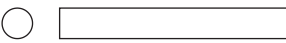
GG. $\Phi 4 \times 30$ mm Metal Pin x 1

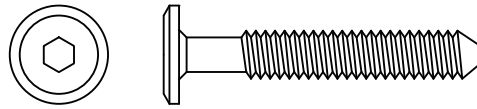
EE. M6 x 40 mm Bolt x 1

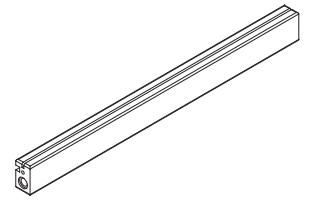
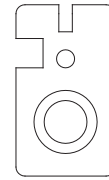

J. Changer Bottom Center Rail x 1

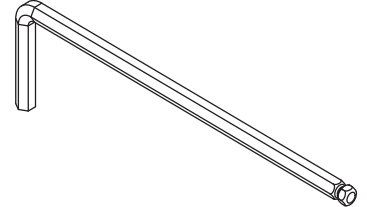

M4 Allen Wrench Supplied

Attach (1) Changer Bottom Center Rail (Part J) to the assembly from step 1 using (1) $\Phi 4 \times 30$ mm Metal Pin (Part GG) and (1) M6 x 40 mm Bolt (Part EE). Tighten with the M4 Allen Wrench.

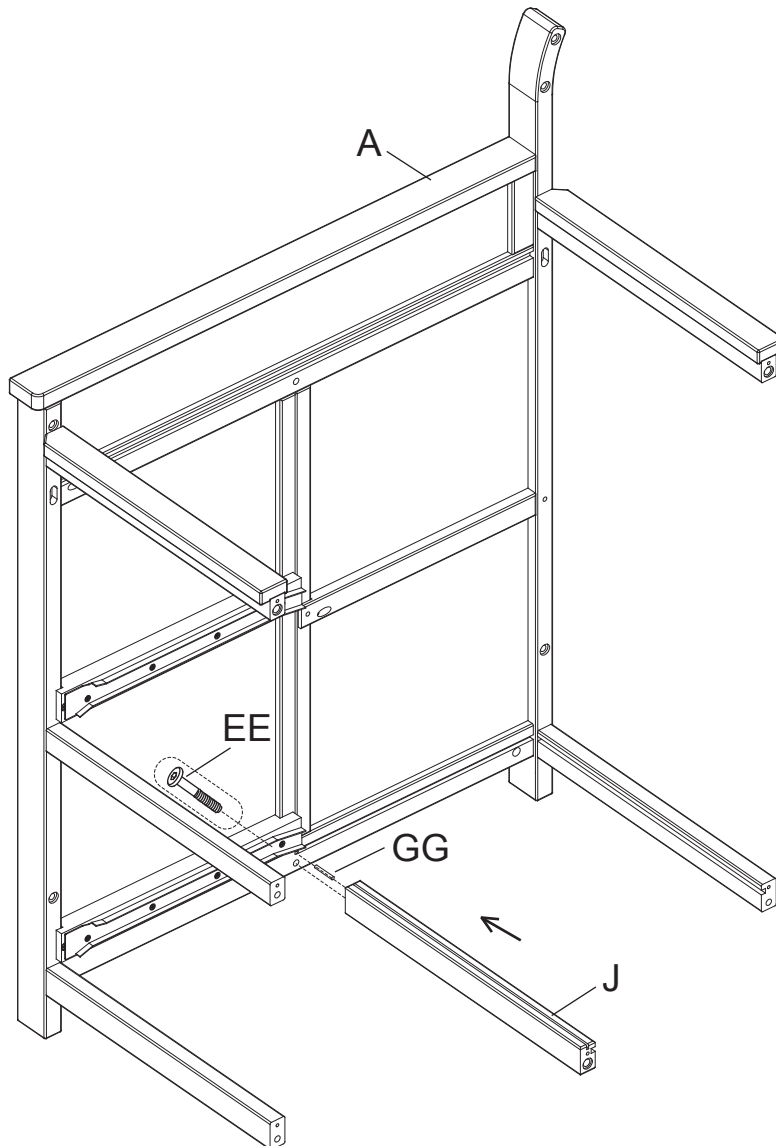

Section 1: Changing Table Assembly

Step 3

Parts and tools required to complete step.

From Step 2

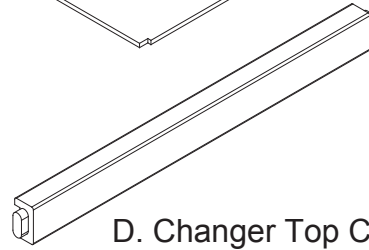
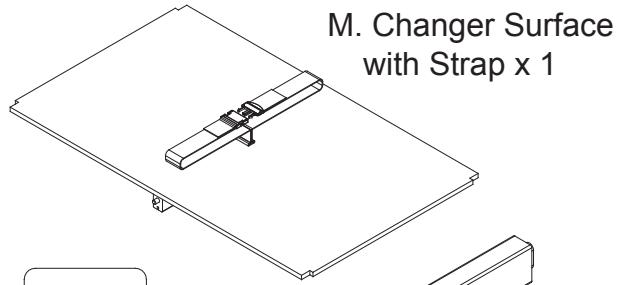
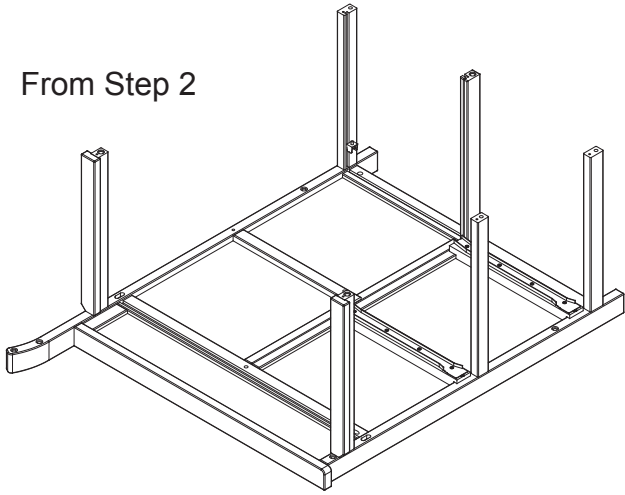

D. Changer Top Center Rail x 2

Lay Common Side (Part A) on It's side and loosely insert (2) Changer Top Center Rails (Part D) as shown.

Slide Changer Surface with Strap (Part M) into Changer Surface Rails (Part D) grooves as shown.

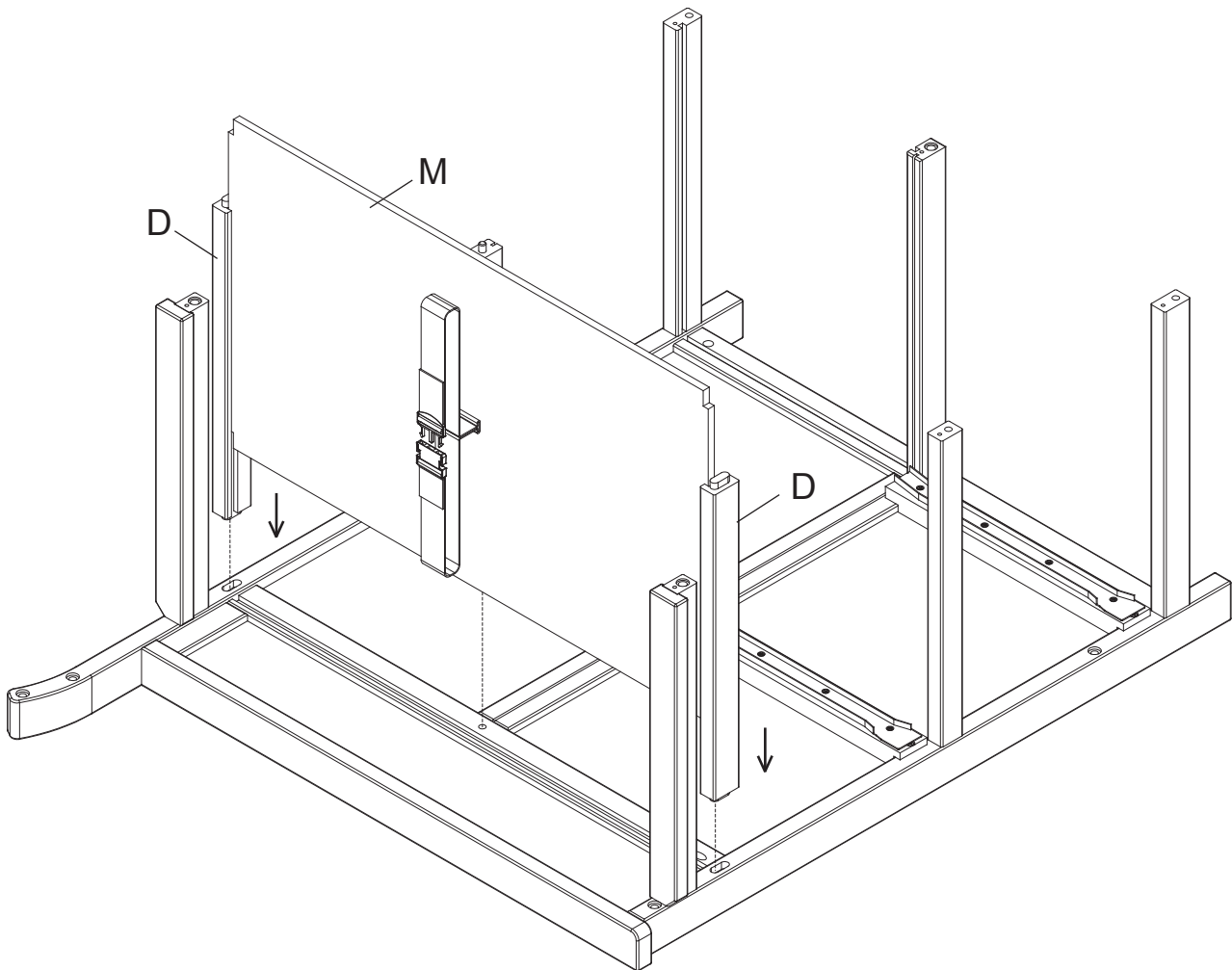

Section 1: Changing Table Assembly

Step 4

Parts and tools required to complete step.

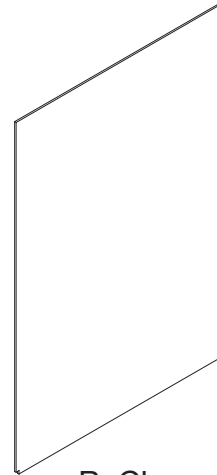
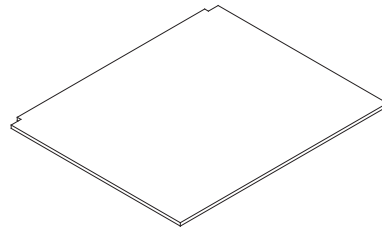
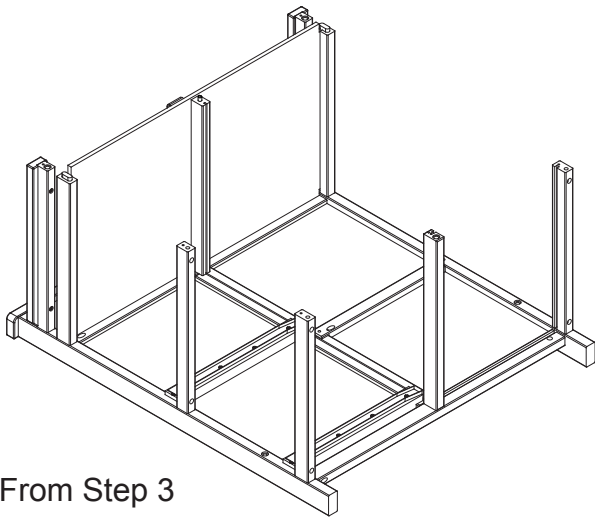

Slide Changer Center Panel (Part P) into Changer Surface with Strap (Part M) and Changer Bottom Center Rail (Part J) grooves as shown.

Slide Changer Fixed Shelf (Part L) into Changer Center Rail (Part J) and Changer Bottom Back Rail (Part H) grooves as shown.

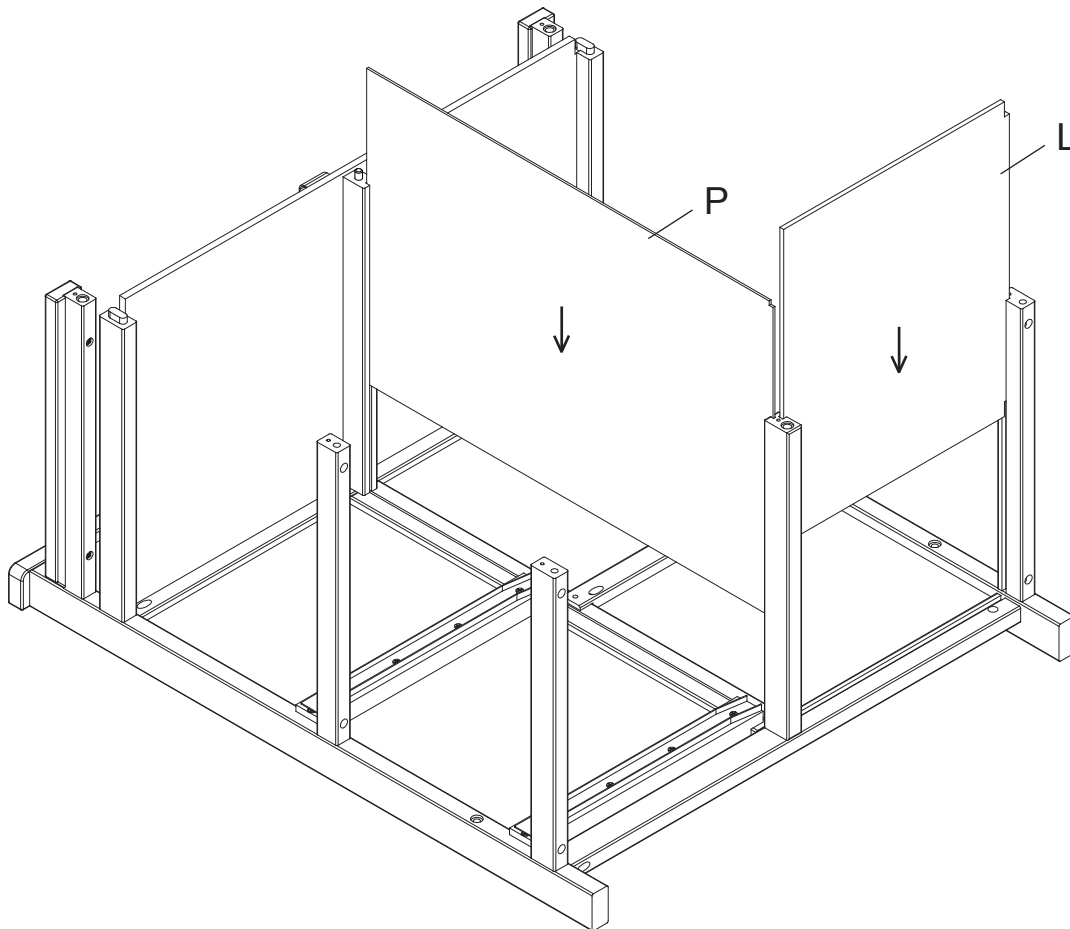

Section 1: Changing Table Assembly

Step 5

Parts and tools required to complete step.

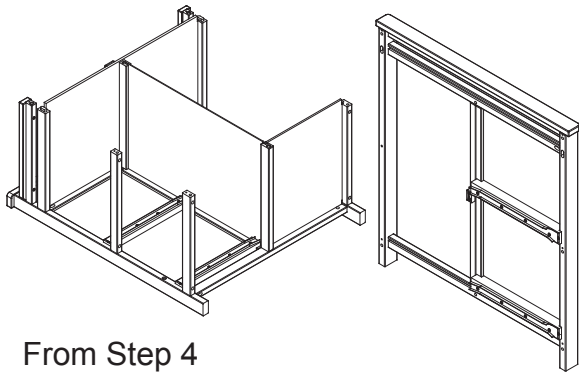

From Step 4

B. Changer End x 1

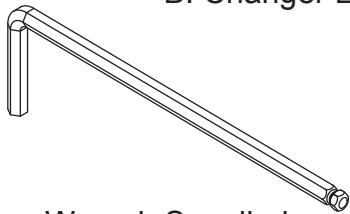

M4 Allen Wrench Supplied

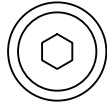

CC. M6 x 85 mm Bolt x 3

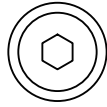
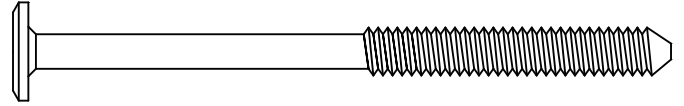

DD. M6 x 60 mm Bolt x 2

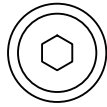
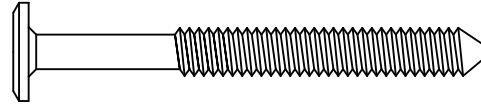

EE. M6 x 40 mm Bolt x 1

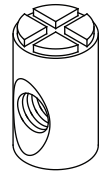

GG. Φ 4x30 mm Metal Pin x 6

HH. M6 x 17 mm Barrel Nut x 3

Attach Changer End (Part B) to the assembly from step 4 using (6) Φ 4x30 mm Metal Pins (Part GG), (1) M6 x 40 mm Bolt (Part EE), (2) M6 x 60 mm Bolt (Part DD), (2) M6 x 85 mm Bolt (Part CC) and (3) M6 x 17 mm Barrel Nuts (Part HH). Tighten with the M4 Allen Wrench. Use the Flat Head Screwdriver to hold the Barrel Nut in the proper alignment.

Note: Before assembly, Carefully align all panels, tabs and pins with the holes and slots in the Changer End (Part B).

ILLUSTRATION ON NEXT PAGE.

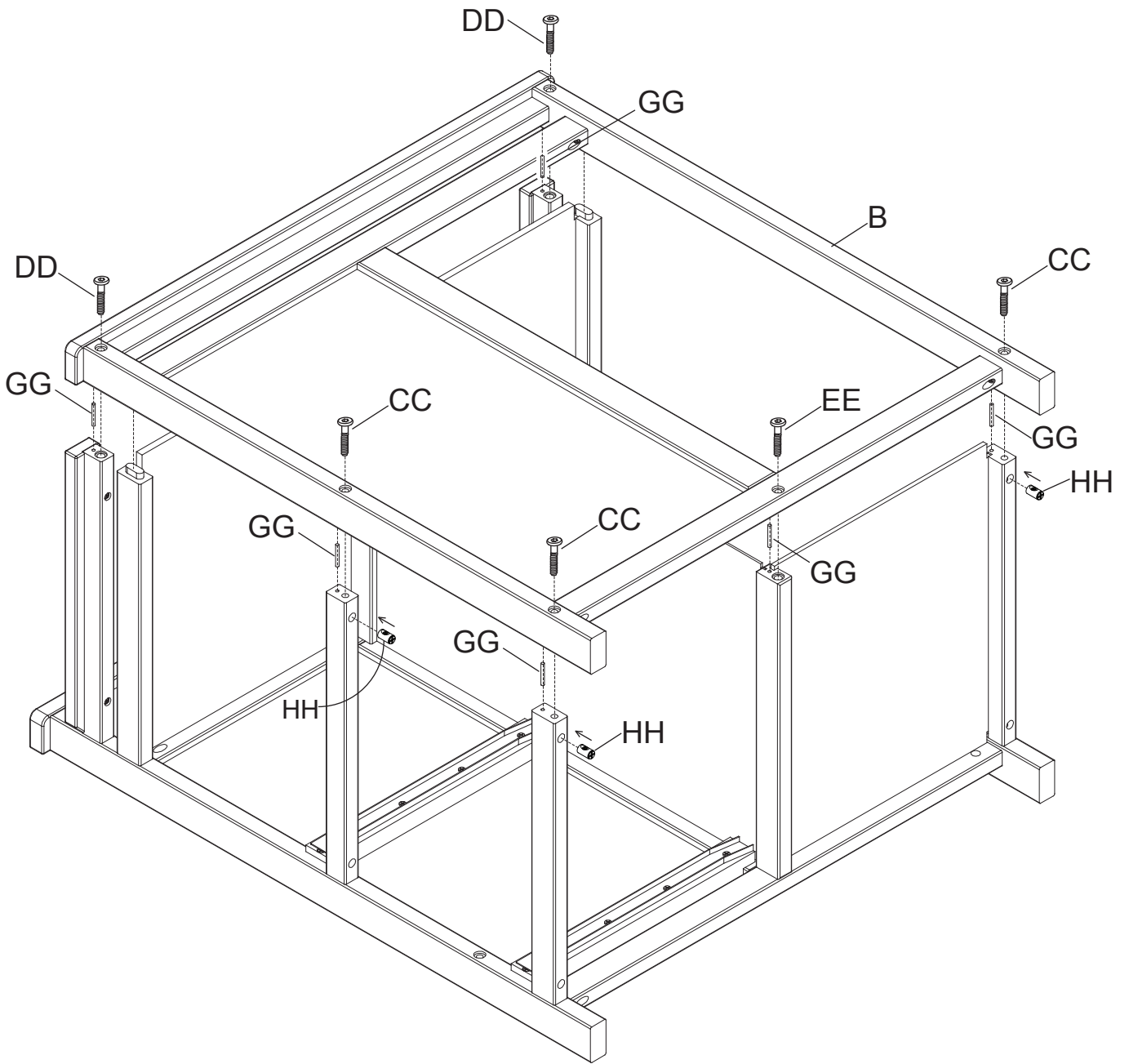

Section 2: Crib Assembly

Step 1

Parts and tools required to complete step.

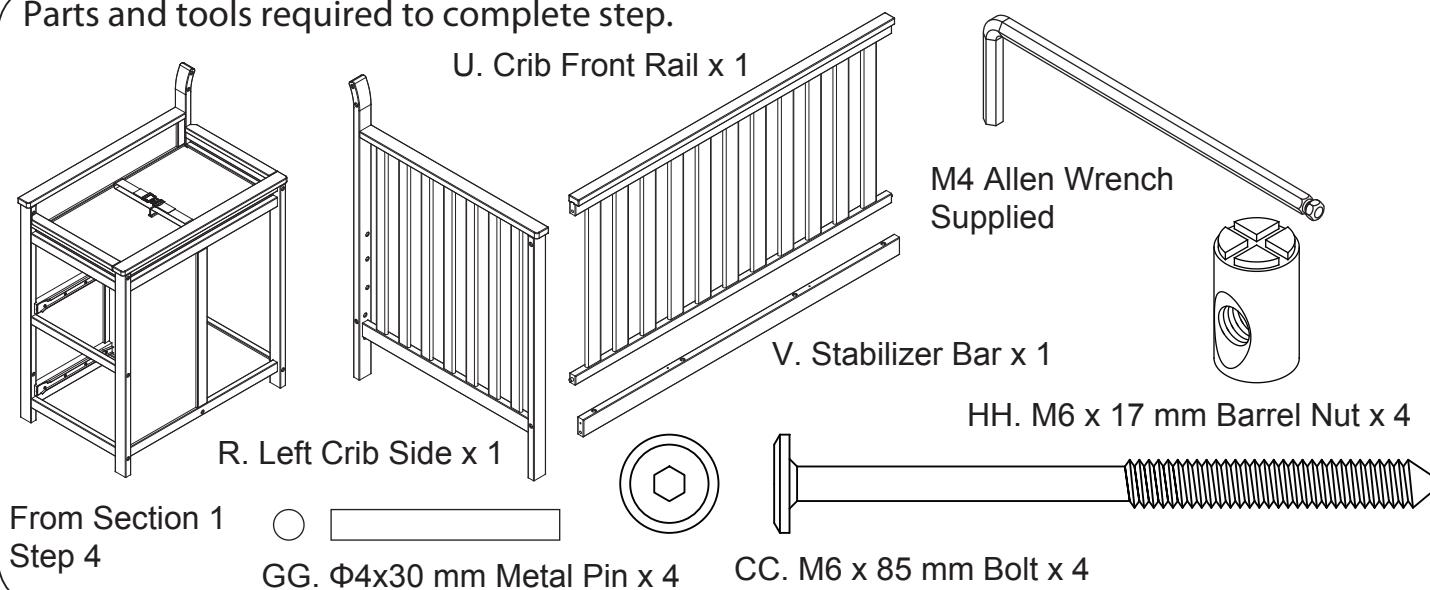

1. Attach (1) Crib Front Rail (Part U) to (1) Stabilizer Bar (Part V) using (2) Φ 4x30 mm Metal Pins (Part GG).
2. Insert (2) Φ 4x30 mm Metal Pins (Part GG) into the hole in each of the Stabilizer Bar (Part V).
3. Attach (1) Crib Front Rail (Part U) and (1) Stabilizer Bar (Part V) to the assembly from section 1 step 4 using (4) M6 x 85 mm Bolts (Part CC) and (4) M6 x 17mm Barrel Nuts (Part HH). Tighten with the M4 Allen Wrench. Use the Flat Head Screwdriver to hold the Barrel Nut in the proper alignment.

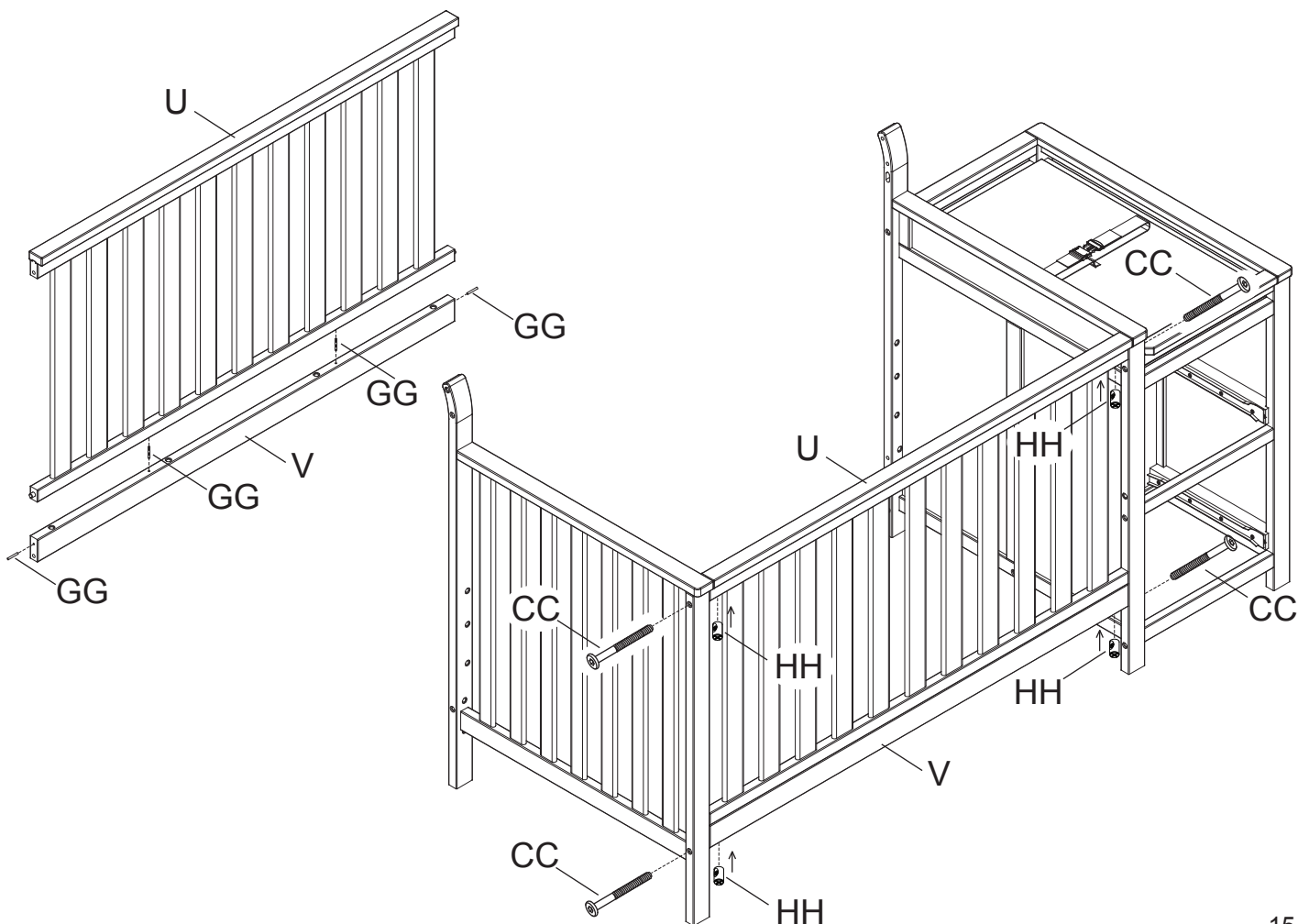

Section 2: Crib Assembly

Step 2

Parts and tools required to complete step.

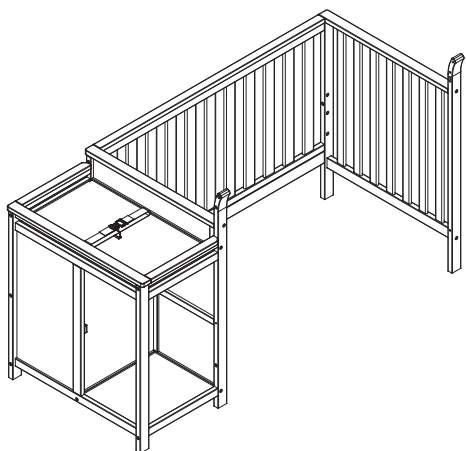

From Section 2
Step 1

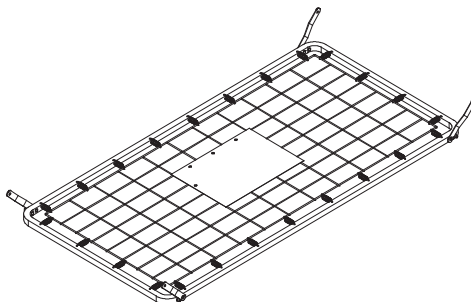

BB. Mattress Support x 1

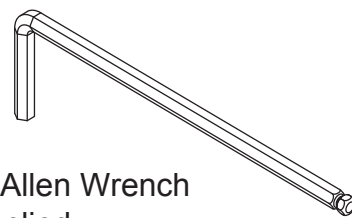

M4 Allen Wrench
Supplied

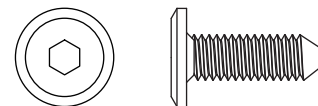

FF. M6 x 18 mm Bolt x 4

Attach the Mattress Support (Part BB) in all corners using (1) M6x18 mm Bolt (Part FF) in each corner. Tighten with the M4 Allen Wrench.

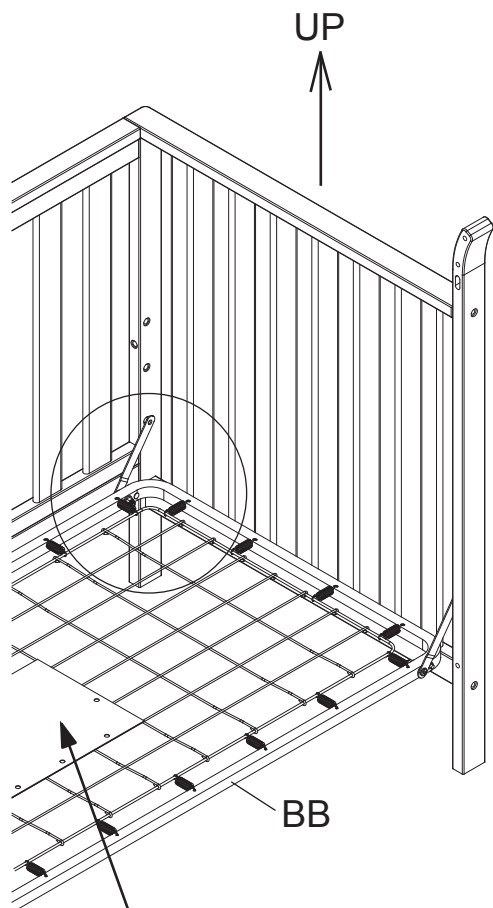

The ⚠ Warnings printed on the pouch attached to the mattress support must face up, the springs must face up. This crib has (3) adjustment positions, use the highest only for new borns, move the mattress down as the child grows.

⚠ WARNING:

Fall Hazard: When child is able to pull to a standing position, set mattress to lowest position and remove bumper pads, large toys and other objects that could serve as steps for climbing out.

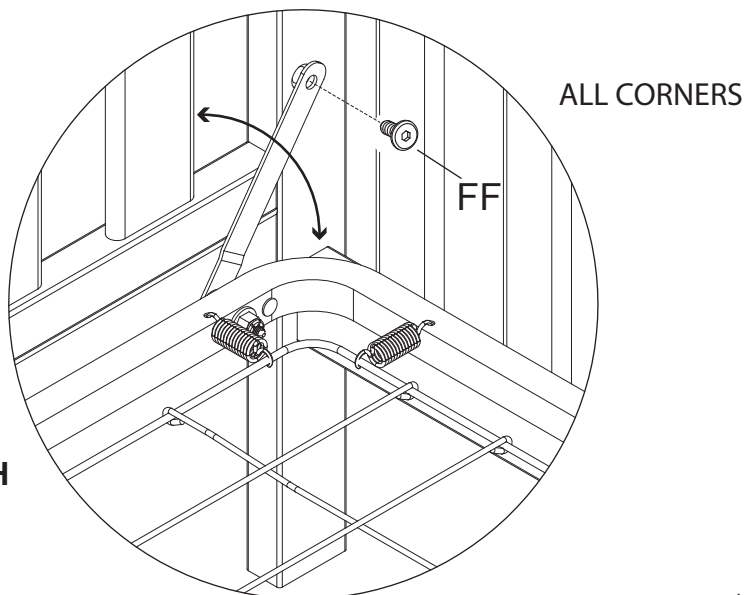

⚠ WARNINGS ON POUCH
MUST FACE UP.

Section 2: Crib Assembly

Step 3

Parts and tools required to complete step.

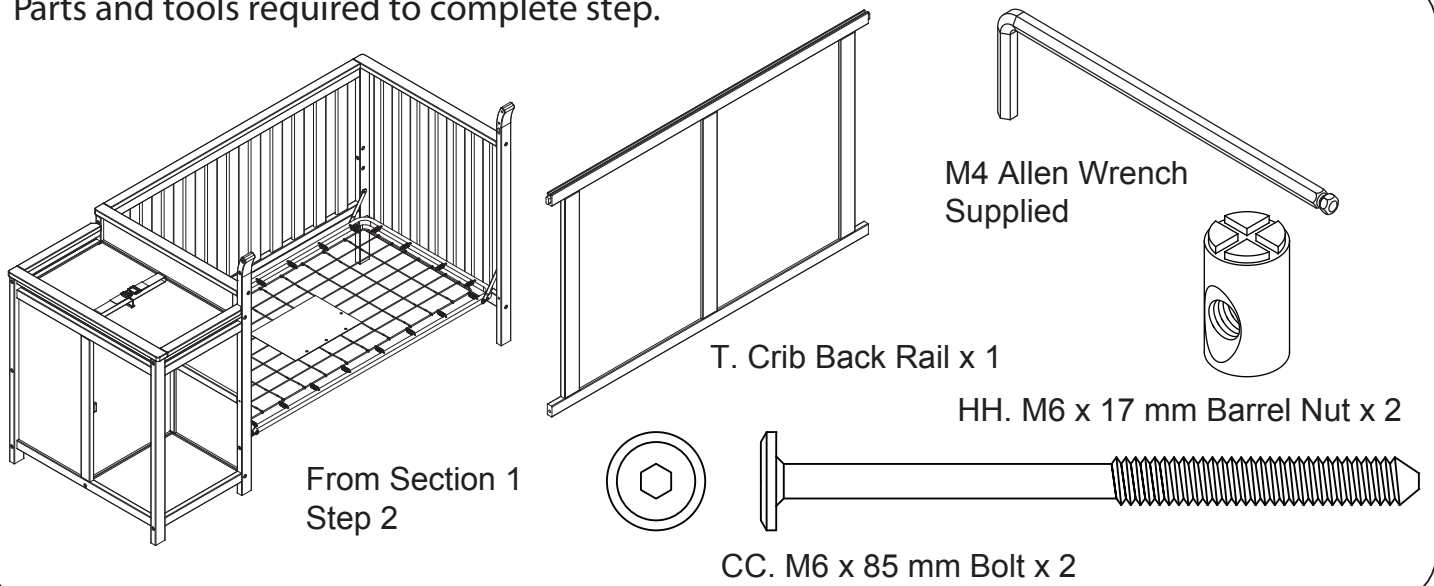

Attach (1) Crib Back Rail (Part T) to the assembly from section 1 step 2 using (2) M6 x 85 mm Bolts (Part CC) and (2) M6 x 17mm Barrel Nuts (Part HH). Tighten with the M4 Allen Wrench. Use the Flat Head Screwdriver to hold the Barrel Nut in the proper alignment. Do not tighten the bolts installed in the pervious step.

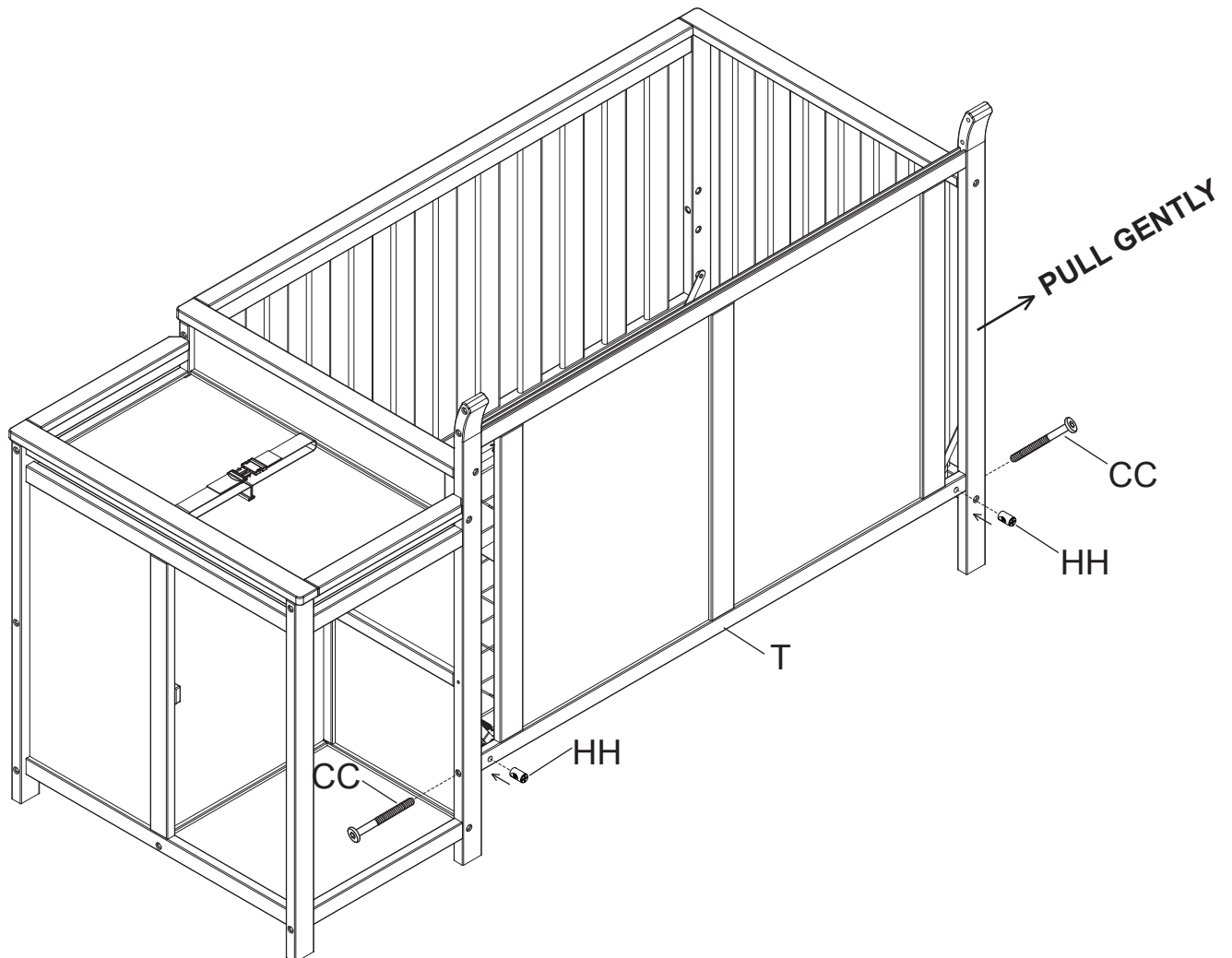

Section 2: Crib Assembly

Step 4

Parts and tools required to complete step.

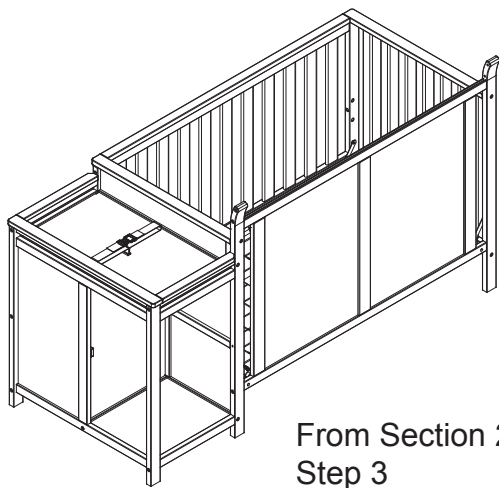

From Section 2
Step 3

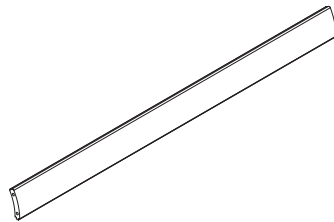

S. Crib Top Back Rail x 1

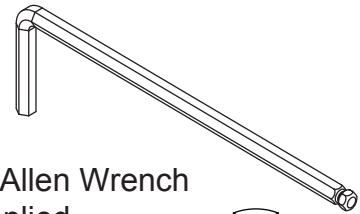

M4 Allen Wrench
Supplied

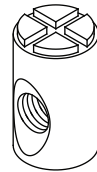

HH. M6 x 17 mm Barrel Nut x 4

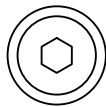

CC. M6 x 85 mm Bolt x 4

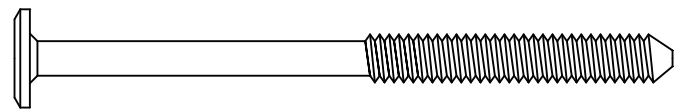

Attach (1) Crib Top Back Rail (Part S) to the assembly from section 2 step 3 using (4) M6 x 85 mm Bolts (Part CC) and (4) M6 x 17 mm Barrel Nuts (Part HH). Tighten all bolts, including the bolt installed loosely in section 2 step 3, with the M4 Allen Wrench. Use the Flat Head Screwdriver to hold the Barrel Nut in the proper alignment.

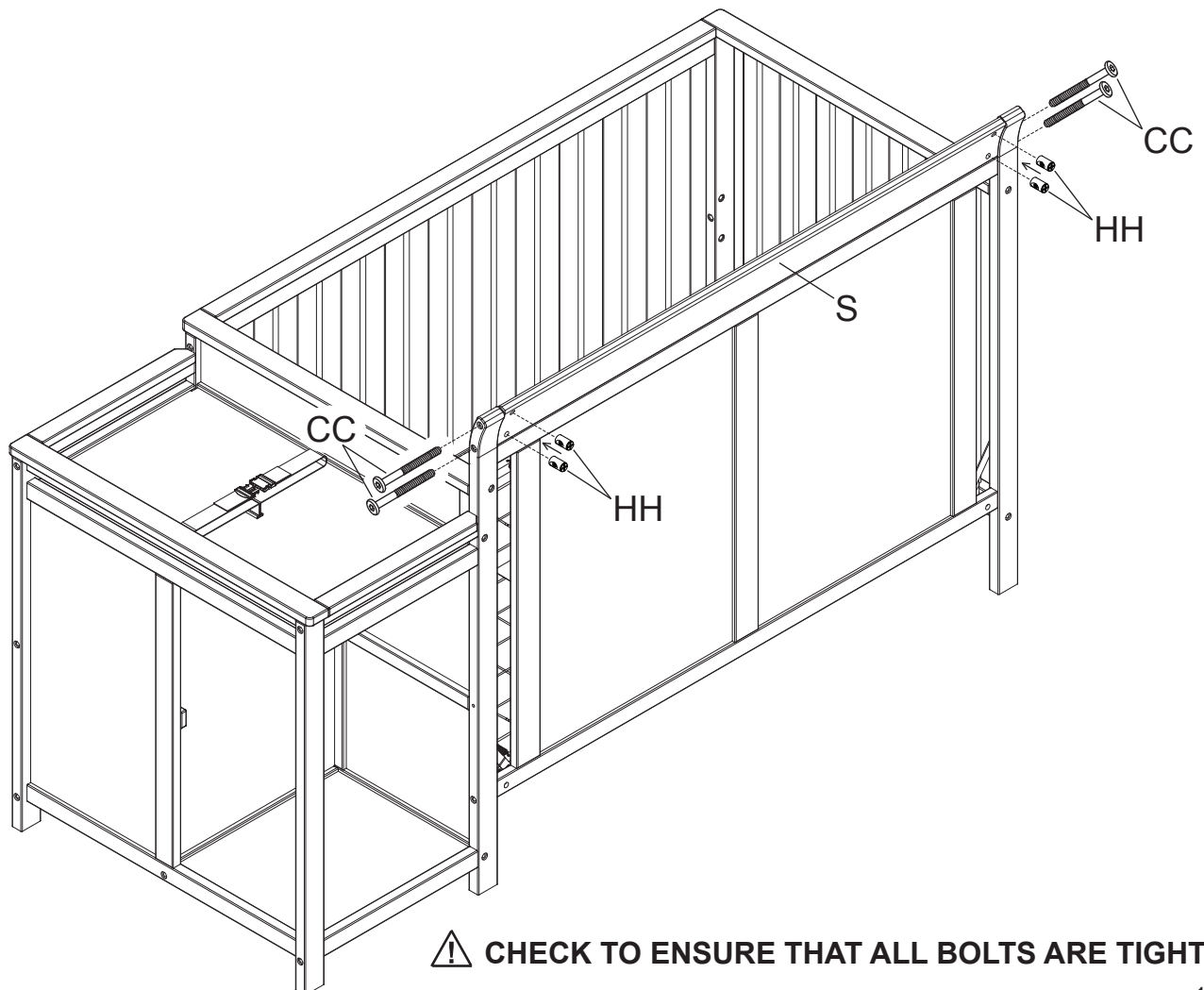

 CHECK TO ENSURE THAT ALL BOLTS ARE TIGHT.

Section 2: Crib Assembly

Step 5

Parts and tools required to complete step.

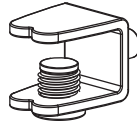
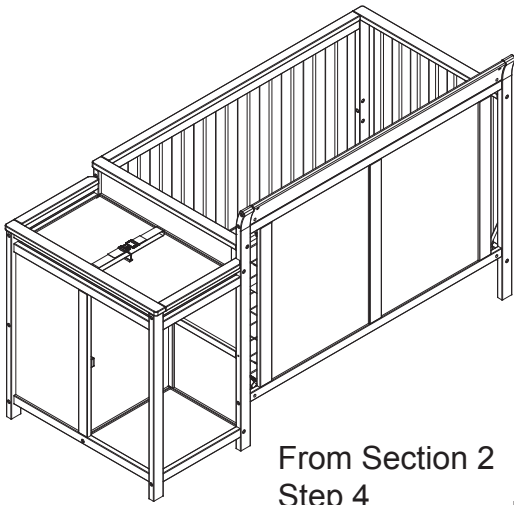

PP. Shelf Clips x 4

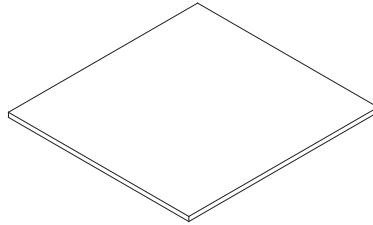

K. Changer Removable Shelf x 1

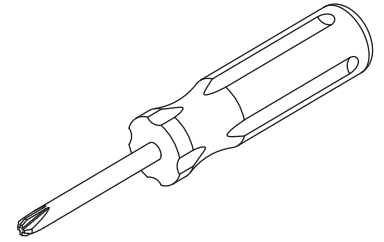

Phillips Screwdriver
(not supplied)

Insert the Shelf Clips (Part PP) in the holes in the posts of the Changing Table. Place the Changer Removable Shelf (Part K) inside the Shelf Clips. Tighten the screws in the Shelf Clips with the Phillips Screwdriver.

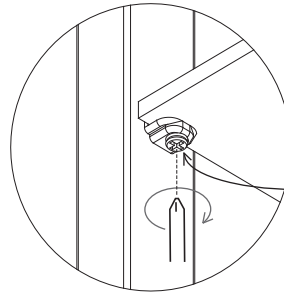

Tighten all clip screws
to hold shelves in
place.

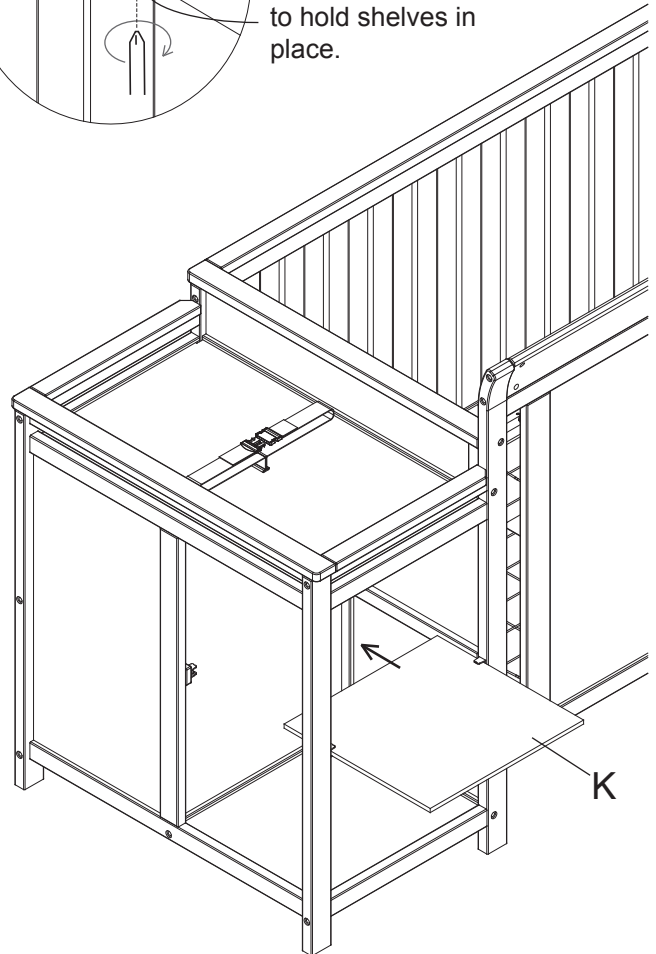
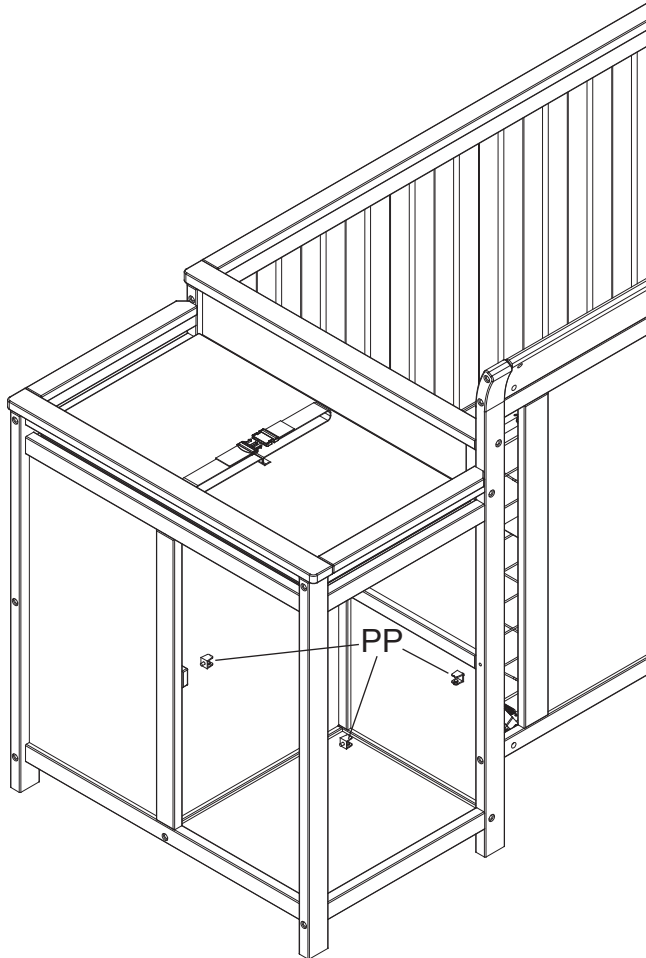

Section 3: Drawer Assembly

Step 1

Parts and tools required to complete step.



JJ. 25 mm Screw x 8

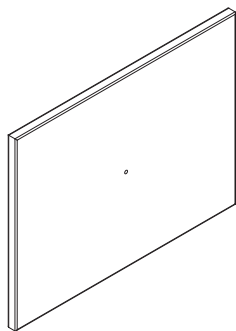

W. Drawer Front x 2

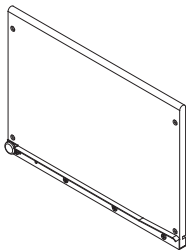

Y. Drawer Left Side x 2

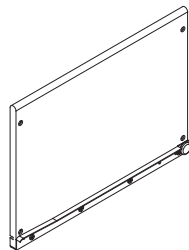

Z. Drawer Right Side x 2

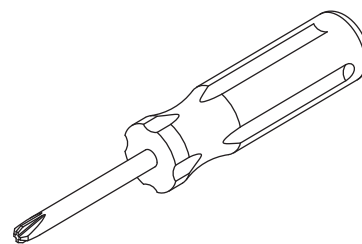

Phillips Screwdriver
(not supplied)

Attach (1) Drawer Left Side (Part Y) and (1) Drawer Right Side (Part Z) to (1) Drawer Front (Part W) with (4) 25mm Screws (Part JJ). Tighten with the Phillips Screwdriver. Repeat on the other Drawer.

Note: Grooves Must Align.

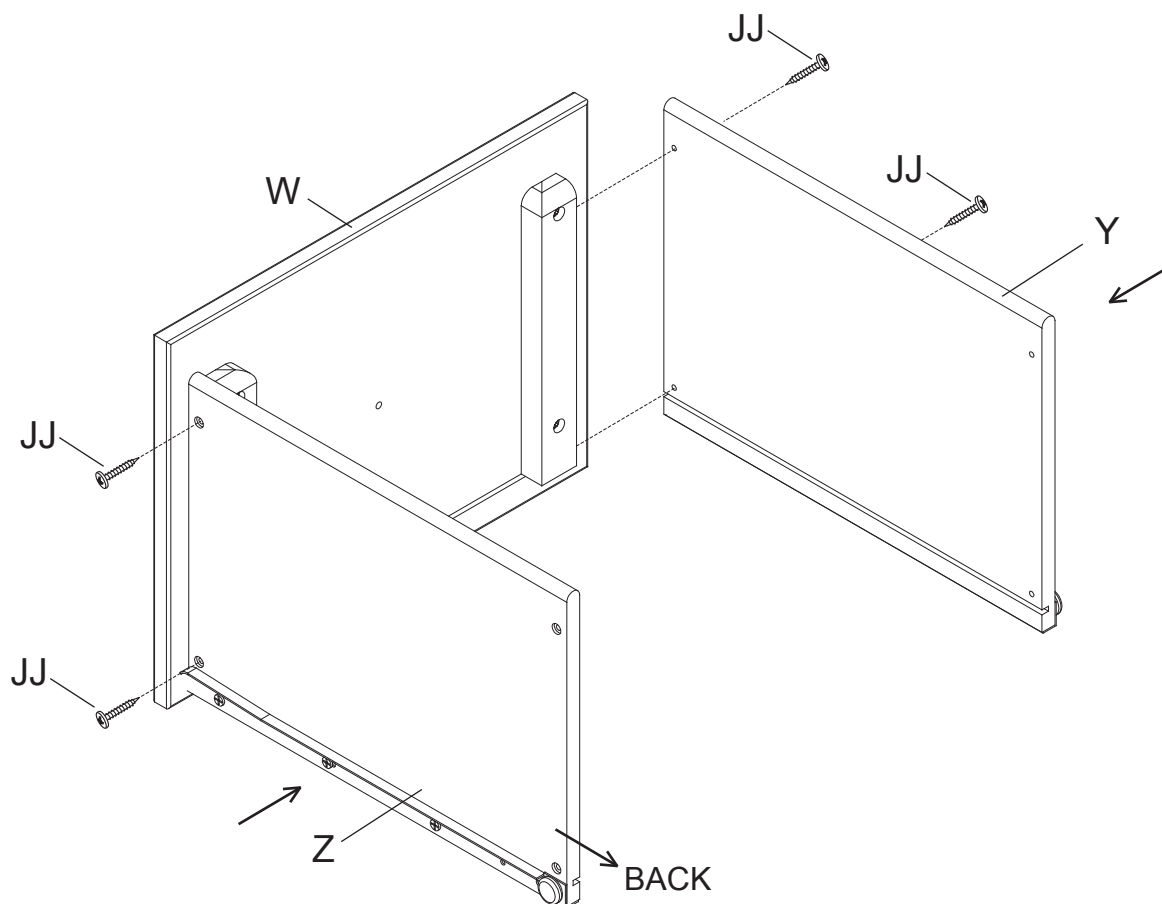

Section 3: Drawer Assembly

Step 2

Parts and tools required to complete step.

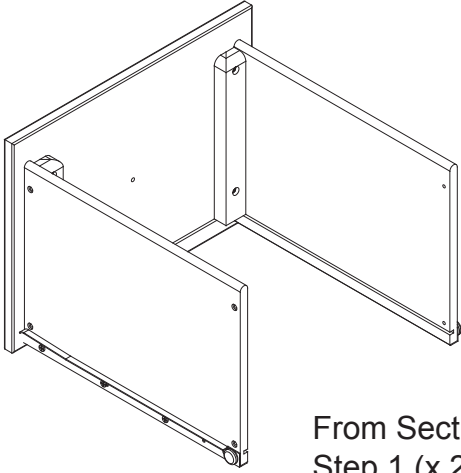

From Section 3
Step 1 (x 2)

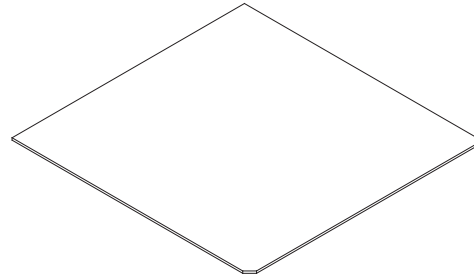

AA. Drawer Bottom Panel x 2

Slide (1) Drawer Bottom Panel (Part AA) in the grooves on the Drawer Left Side and Drawer Right Side, into the groove on the Drawer Front. Repeat on the other drawer.

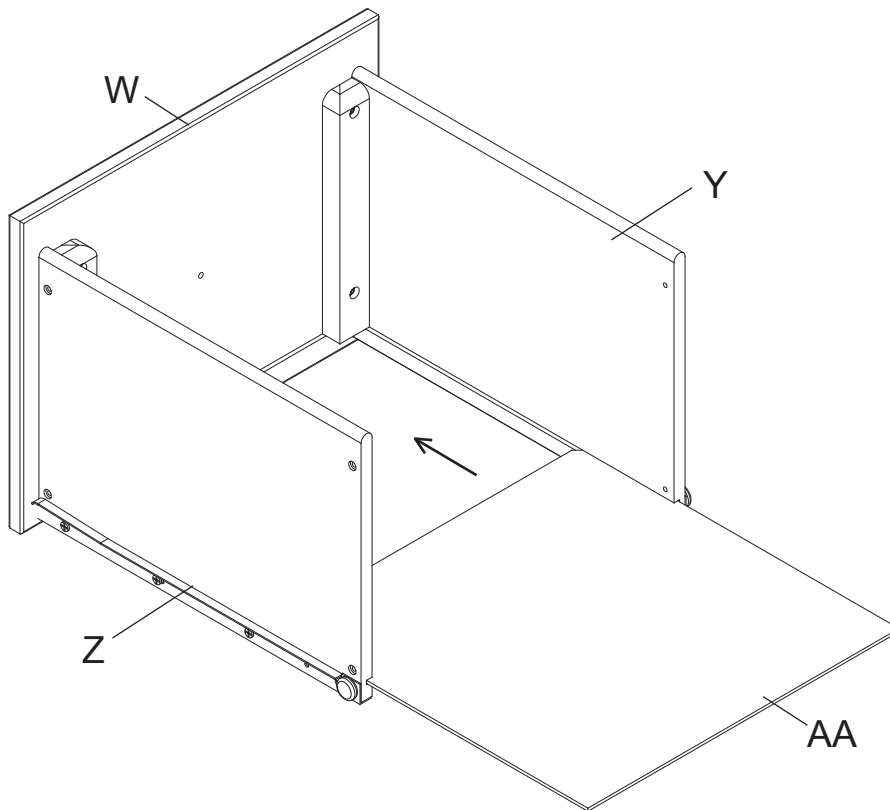

Section 3: Drawer Assembly

Step 3

Parts and tools required to complete step.

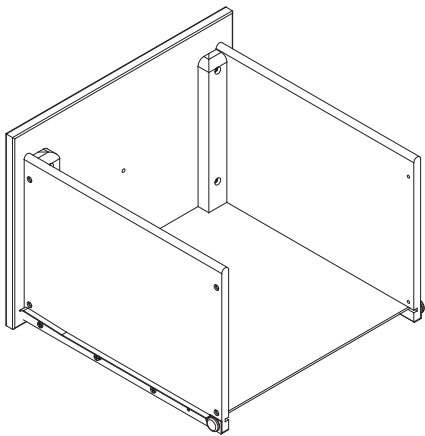

From Section 3
Step 2 (x 2)



LL. Plastic Barrel Nut x 8



KK. 40 mm Screw x 8

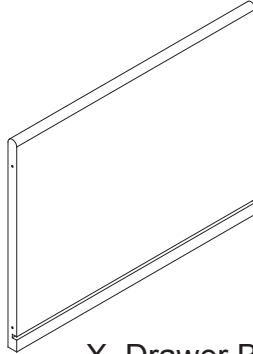

X. Drawer Back x 2

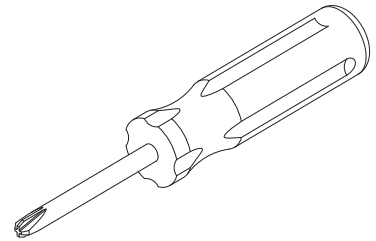

Phillips Screwdriver
(not supplied)

Attach (1) Drawer Back (Part X) to the assembly from section 3 step 2 with (4) 40 mm Screws (Part KK) and (4) Plastic Barrel Nut (Part LL). Use the Flat Head Screwdriver to hold the Plastic Barrel Nut in the proper alignment. Tighten with the Phillips Screwdriver. Repeat on the other drawer.

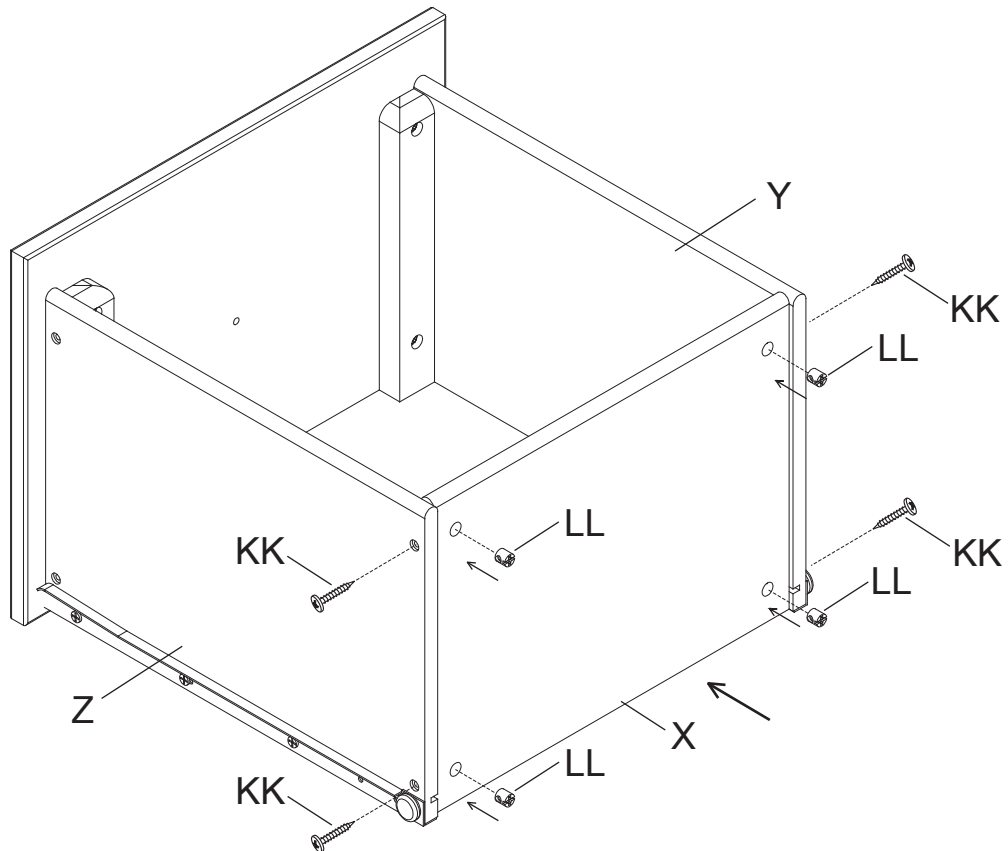

Section 3: Drawer Assembly

Step 4

Parts and tools required to complete step.

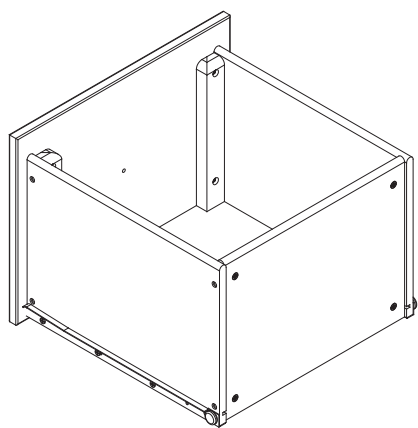

From Section 3
Step 3 (x 2)

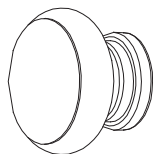

MM. Handle x 2



NN. Handle Bolt x 2

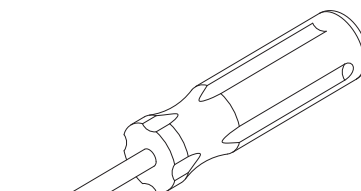

Phillips Screwdriver
(not supplied)

Attach (1) Handle (Part MM) to the assembly from section 3 step 3 with (1) Handle Bolt (Part NN). Tighten with the Phillips Screwdriver. Repeat on the other Drawer.

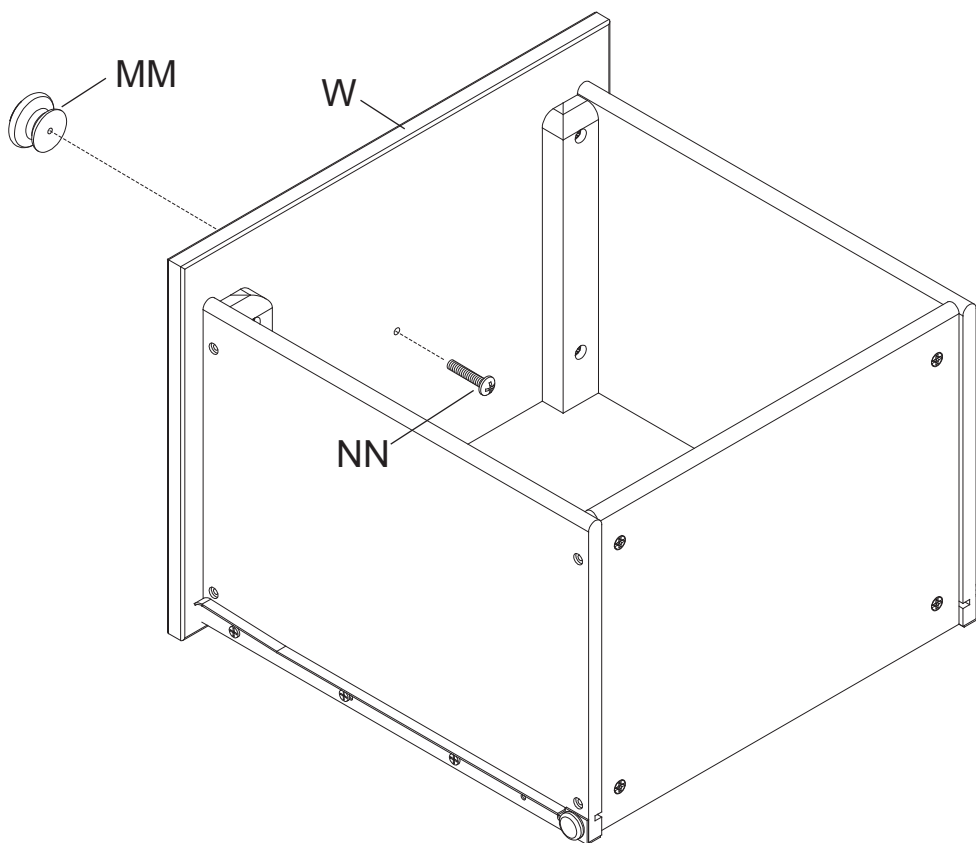

Section 3: Drawer Assembly

Step 5

Parts and tools required to complete step.

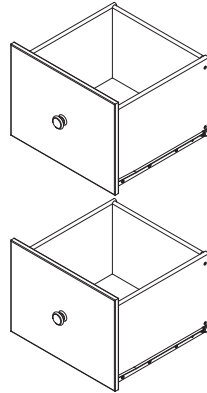
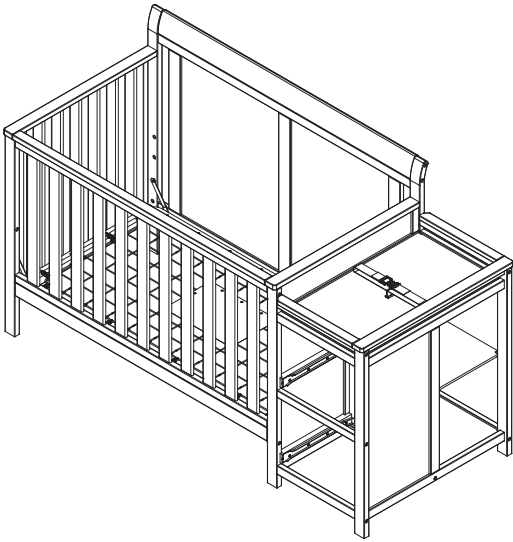

From Section 3 Step 4

Insert the Drawers as shown.

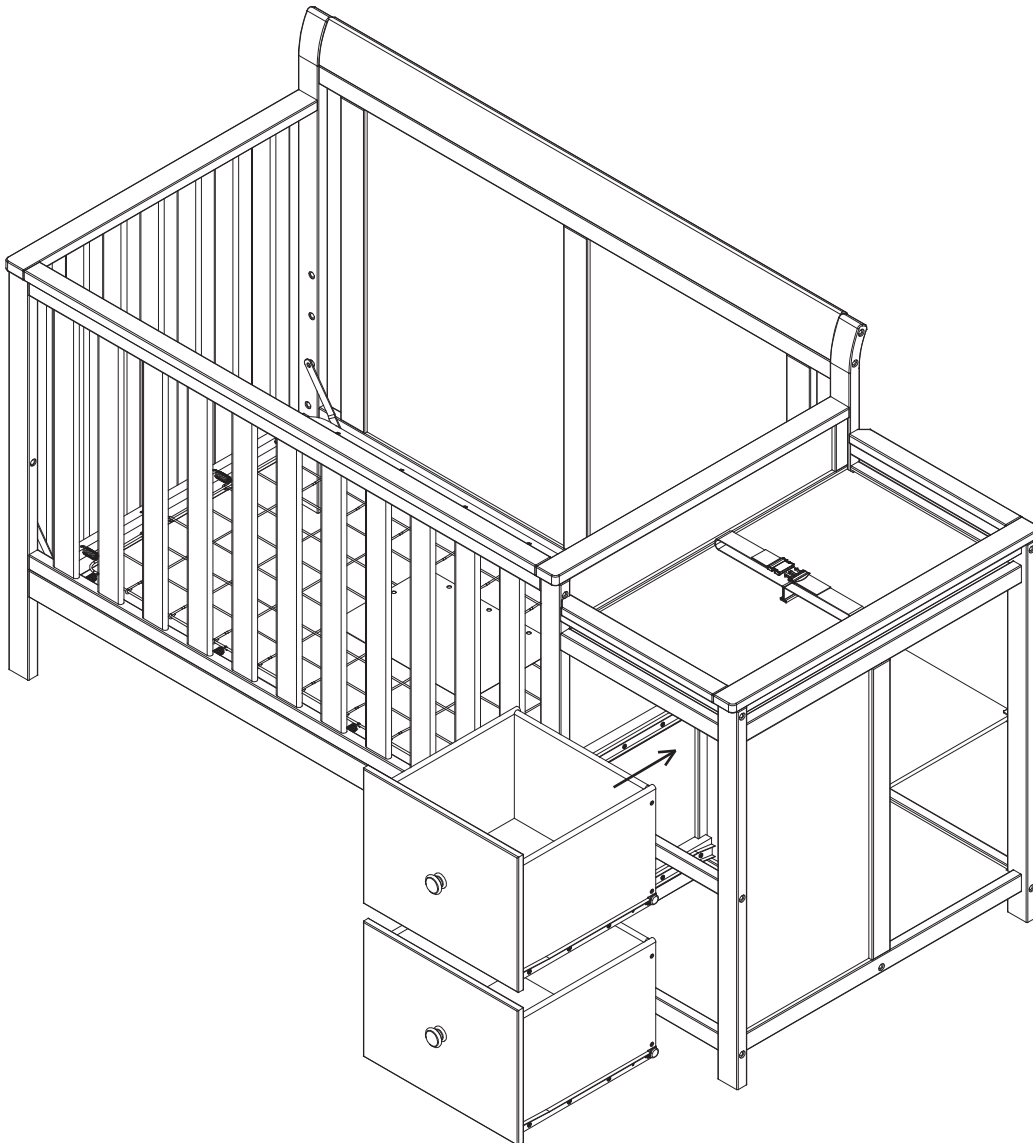

Section 4: Step 1 Changing Pad attachment and use

Parts and tools required to complete step.

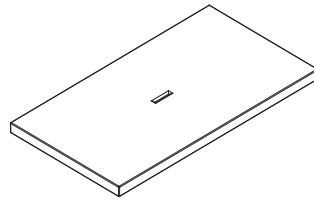

N. Changer Pad x 1

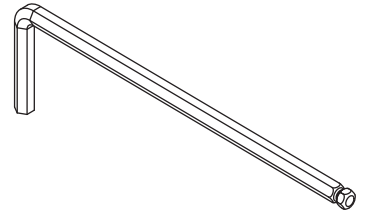

M4 Allen Wrench
Supplied

1. Check that the bolt securing the strap is tight using M4 Allen Wrench.
2. Insert the Strap through the hole in the Changing Pad (Part N).
3. Place Pad on changing surface.

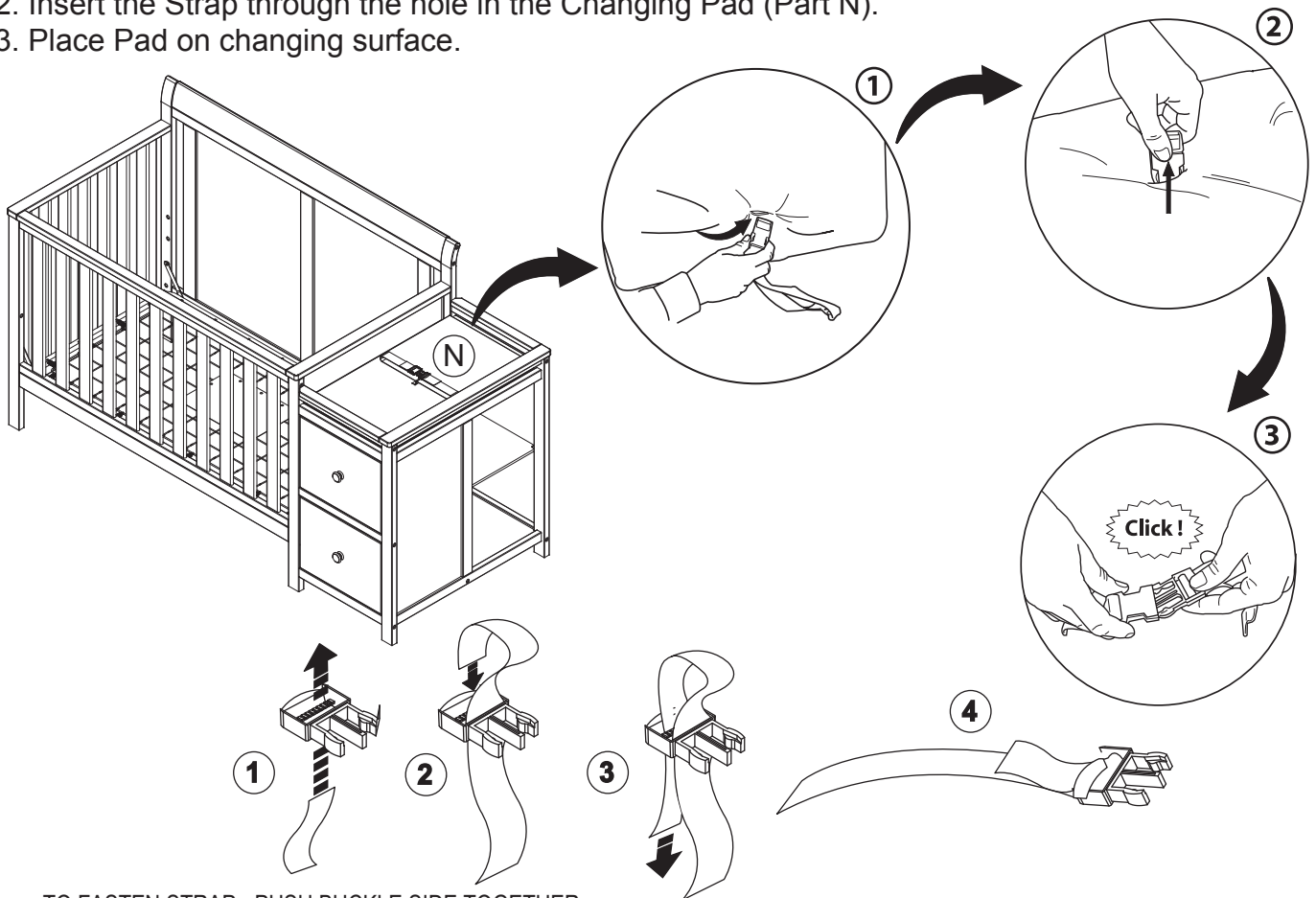

TO FASTEN STRAP - PUSH BUCKLE SIDE TOGETHER
BE SURE BUCKLE IS FULLY FASTENED TO
SECURE CHILD SAFELY

TO RELEASE PRESS BOTH TABS AND PULL APART

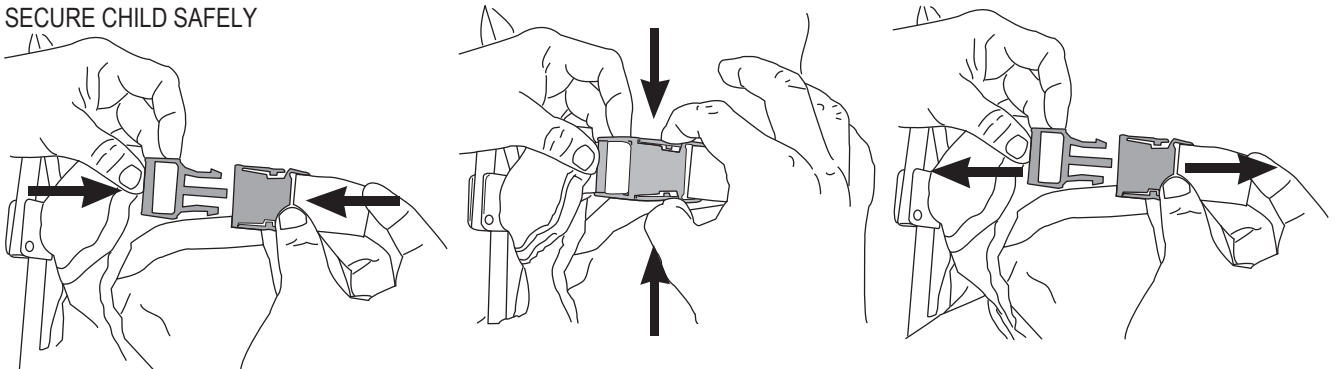

Section 4: Step 2 Storing Instruction Booklet

Parts and tools required to complete step.

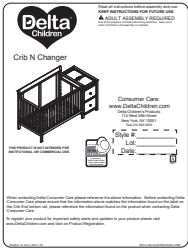

Assembly Instruction
Booklet

Store the assembly instruction booklet in the pouch attached to the mattress support. Store all parts and tools separately, in a safe place.

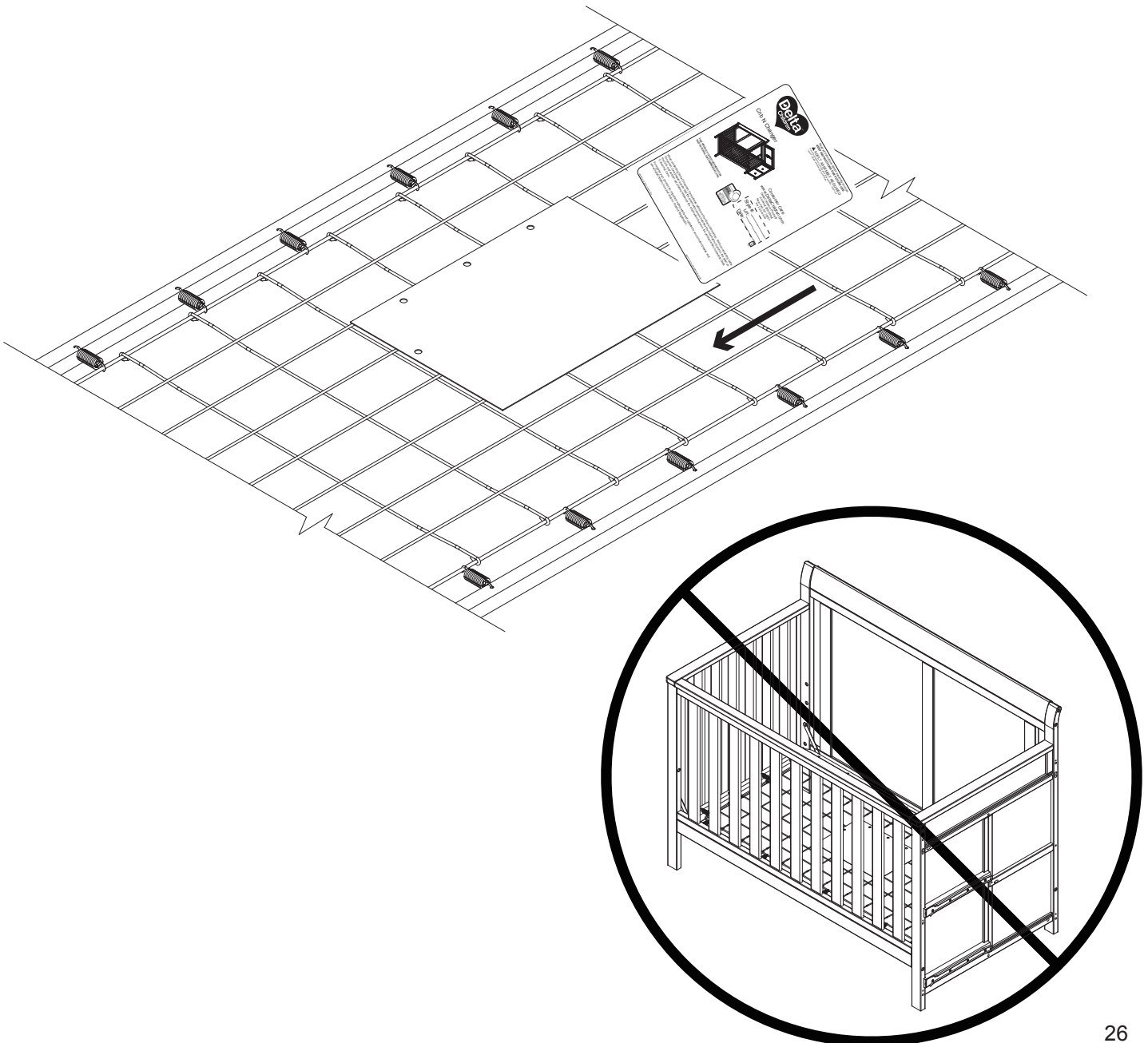

Section 5: Toddler Bed Conversion

Step 1

Parts and tools required to complete step.

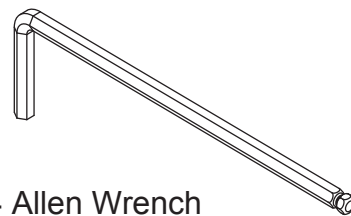

M4 Allen Wrench
Supplied

Remove the Crib Front Rail and Stabilizer Bar installed in Step 1 of Section 2 crib assembly.

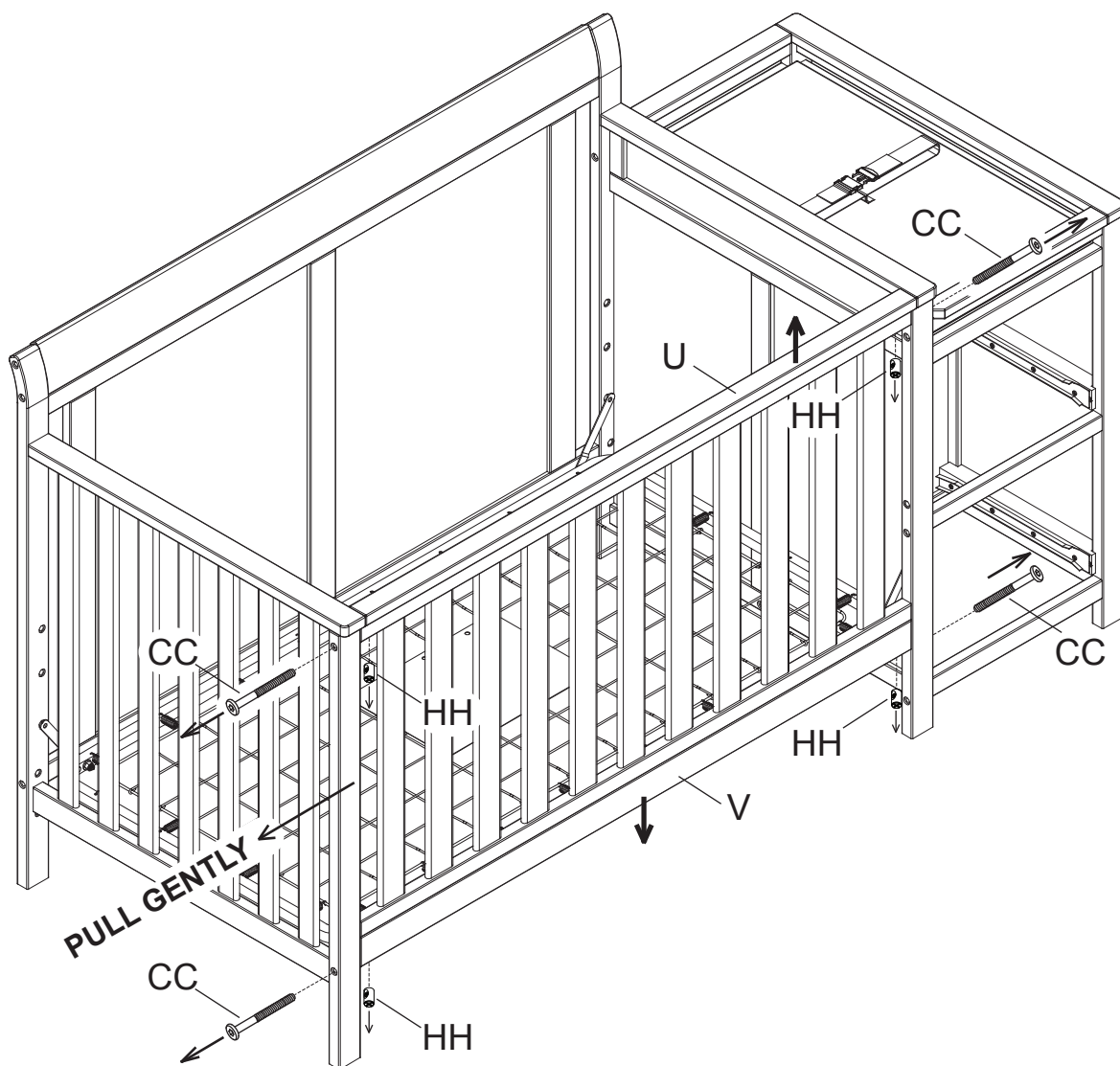

Section 5: Toddler Bed Conversion

Step 2

Parts and tools required to complete step.

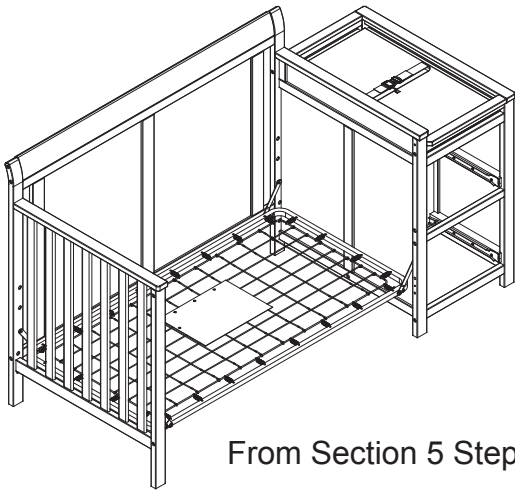

GG. $\Phi 4 \times 30$ mm Metal Pin x 2

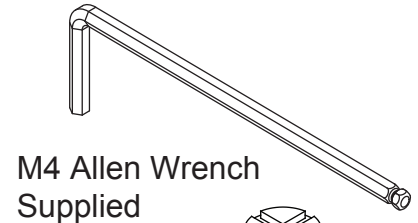

V. Stabilizer Bar x 1

HH. M6 x 17 mm Barrel Nut x 2

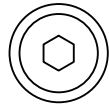

CC. M6 x 85 mm Bolt x 2

Attach (1) Stabilizer Bar (Part V) to the assembly from section 5 step 1 using (2) $\Phi 4 \times 30$ mm Metal Pins (Part GG), (2) M6 x 85 mm Bolts (Part CC) and (2) M6 x 17mm Barrel Nuts (Part HH). Tighten with the M4 Allen Wrench. Use the Flat Head Screwdriver to hold the Barrel Nut in the proper alignment.

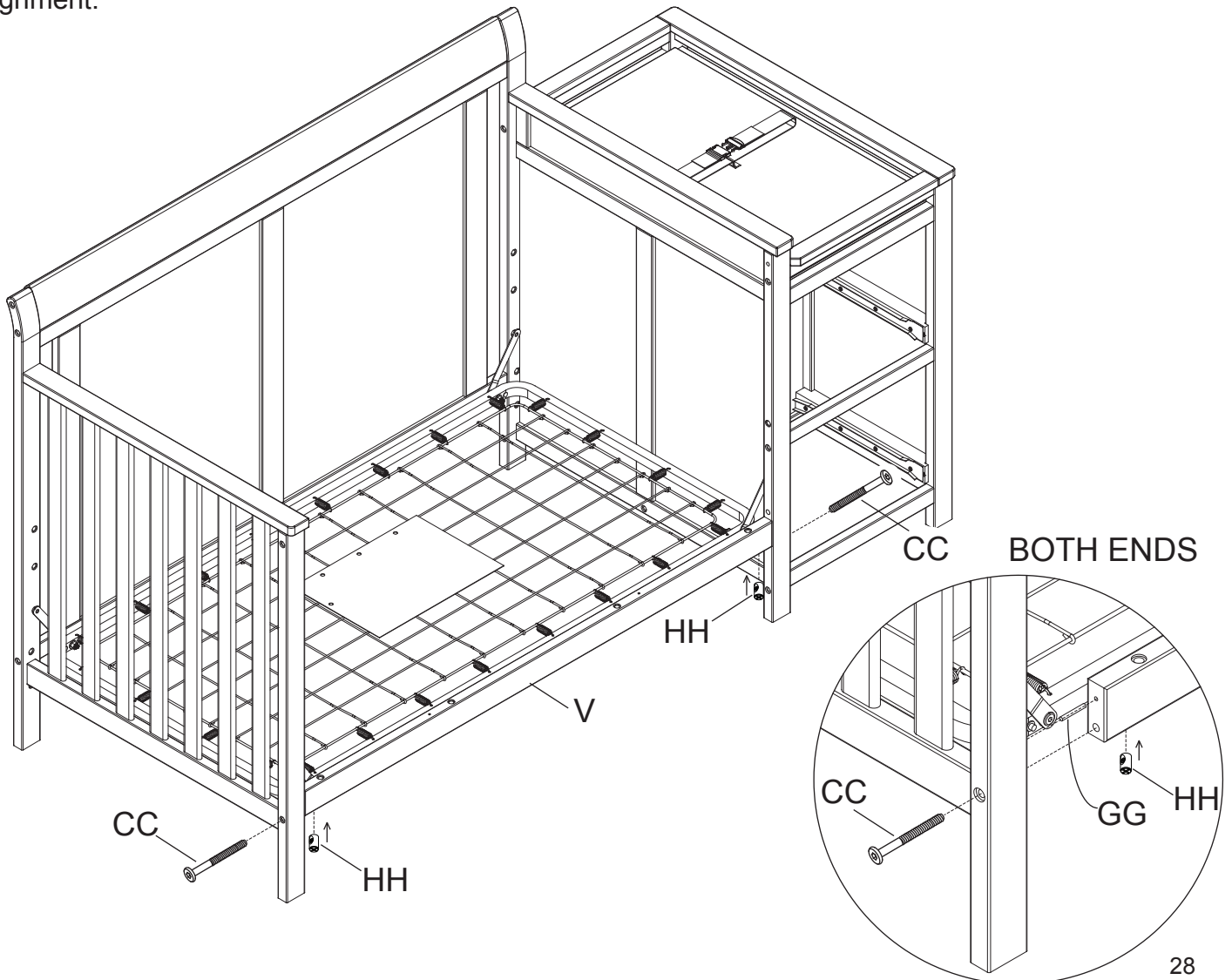

Section 5: Toddler Bed Conversion

Step 3

WARNING: **SEE PAGE 3 FOR TODDLER BED WARNINGS**

The mattress support must be in the lowest position.

Store all hardware safely.

Read all warnings on page 3.

As shown, use as a day bed or love seat sofa.

Do Not use without stabilizer bar installed.

Check to ensure all bolts are tight.

 Stabilizer bar must be used when converted to a toddler bed.

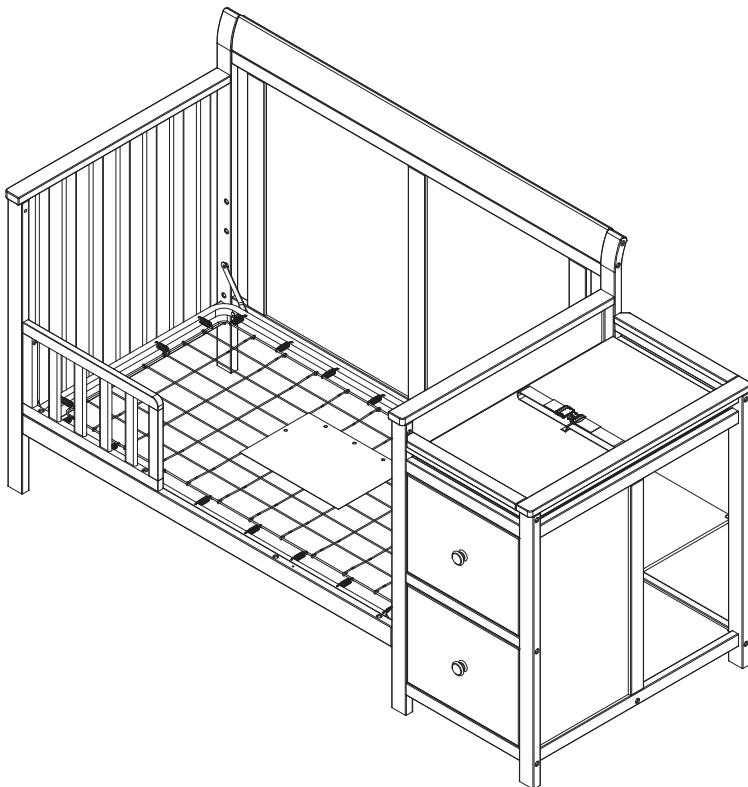
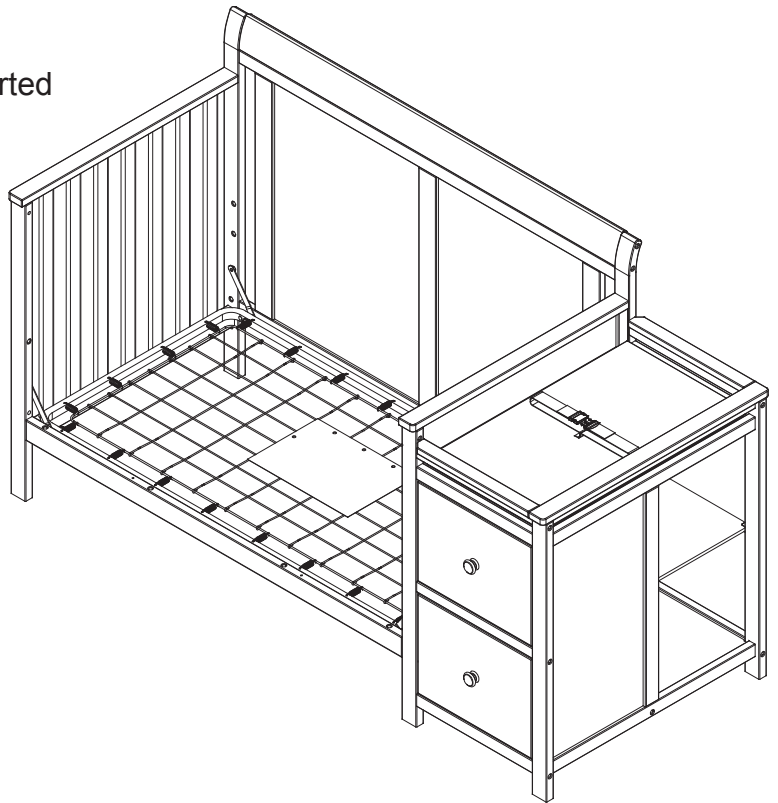

A toddler bed guardrail is available for this crib.
Please see your crib retailer, visit www.DeltaChildren.com or contact Delta Consumer Care for more information.
This crib uses Delta Style # 0080 Guardrail.

Section 6: Full Size Bed Conversion

Step 1

Parts and tools required to complete step.

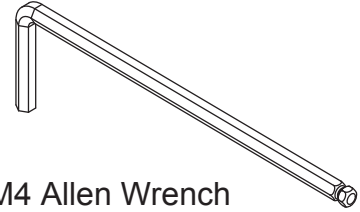

M4 Allen Wrench
Supplied

Remove shelves and shelf clips. Disassemble the Changer unit by reversing all steps in section 1: Changer Assembly. Remove the post from the Common Side (Part A) by removing the bolts. Store all parts carefully for future use, see page 3 for information.

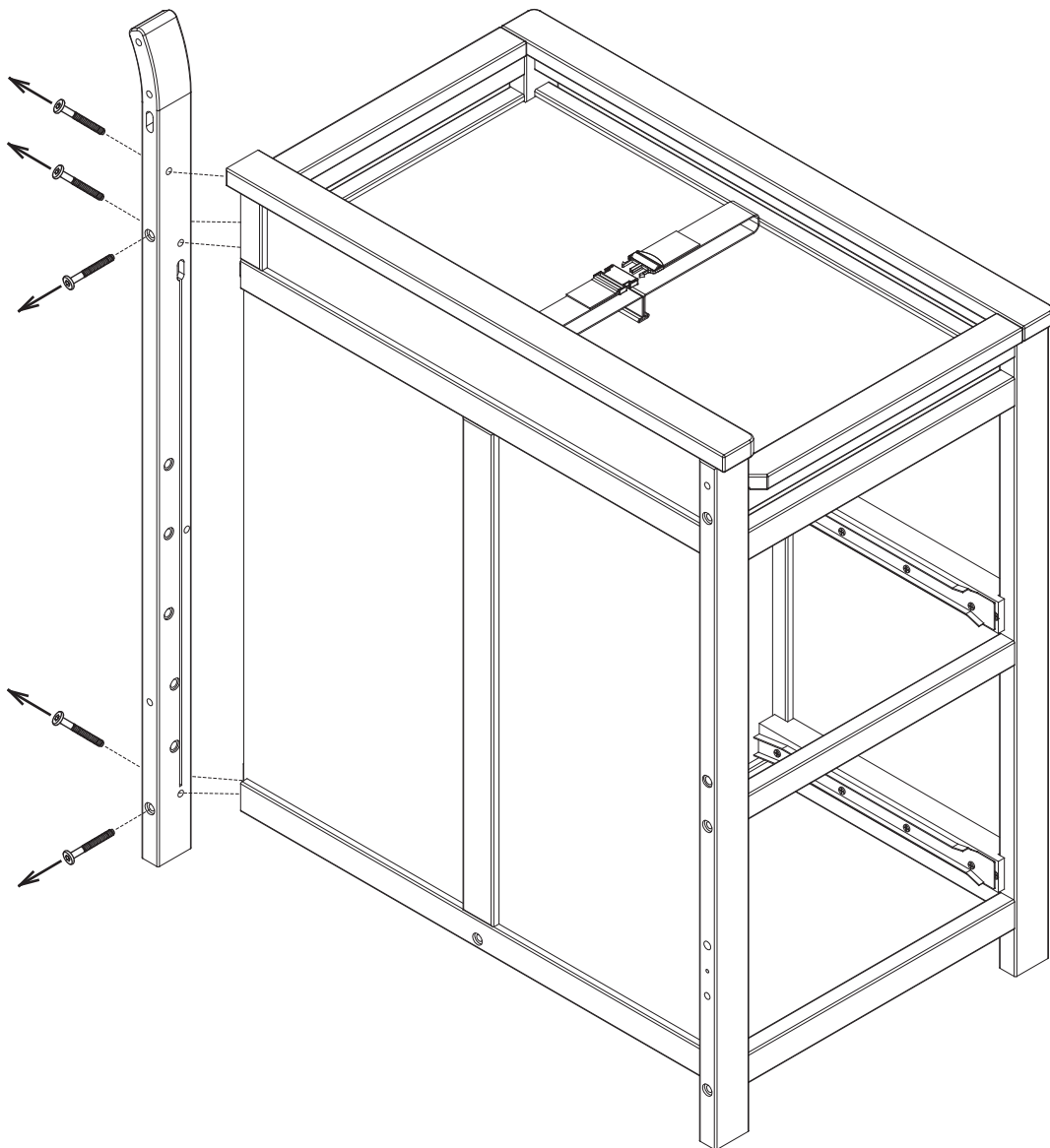

Section 6: Full Size Bed Conversion

Step 2

Parts and tools required to complete step.

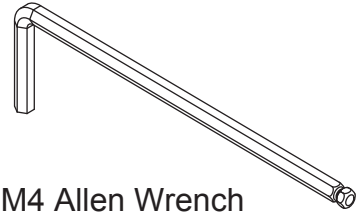

M4 Allen Wrench
Supplied

Disassemble the Crib End by removing the preassembled bolts with the M4 Allen Wrench. Attach the post removed from the changer in the previous step to the end of the Crib Back Side where it was previously attached using (3) M6x85mm Bolts (Part CC) and (3) M6x17mm Barrel Nuts (Part HH). Tighten bolts with the M4 Allen Wrench. Use the Flat Head Screwdriver to hold the Barrel Nut in the proper alignment.

Store all parts and hardware in a safe place. See page 3 for information.

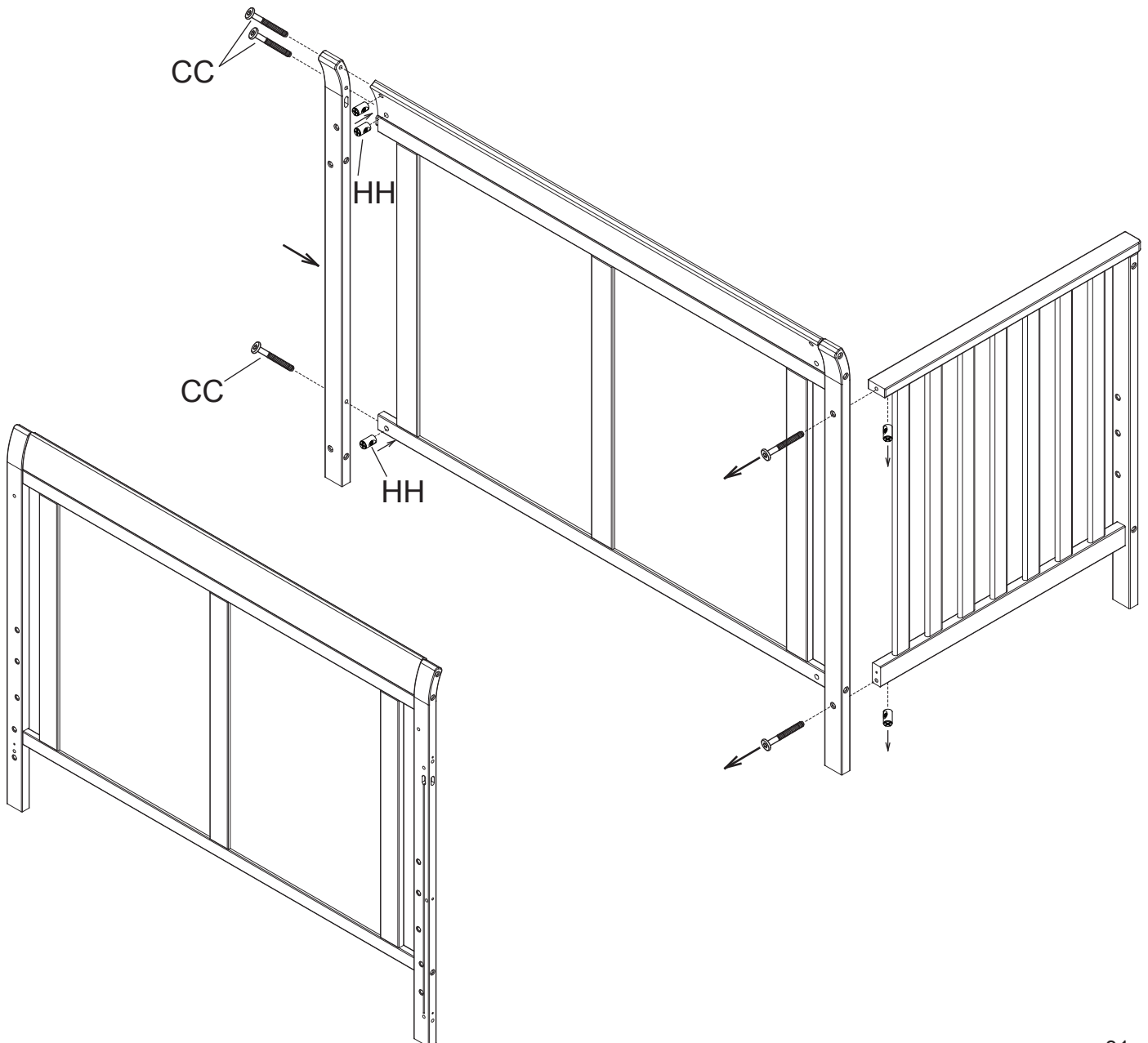

Section 6: Full Size Bed Conversion

Step 3

Parts and tools required to complete step.

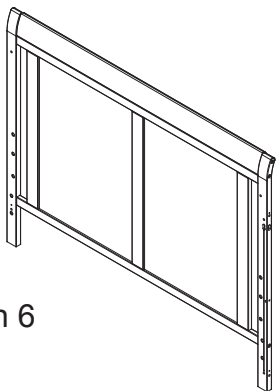

From Section 6
Step 2

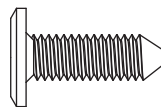
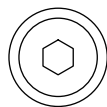

FF. M6 x 18 mm Bolt x 4

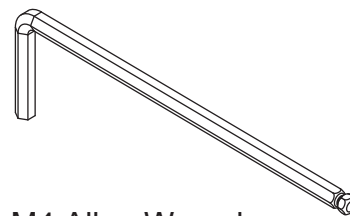

M4 Allen Wrench
Supplied

Attach Bed Frame to the Headboard (From Section 6 Step 2) using (4) M6x18mm Bolts (Part FF). Follow all instructions supplied with the Bed Frame. **Note:** Bed Frame system is not included, This item uses Delta item 0040 bed frame, please see retailer or contact Delta Consumer Care for information or with questions.

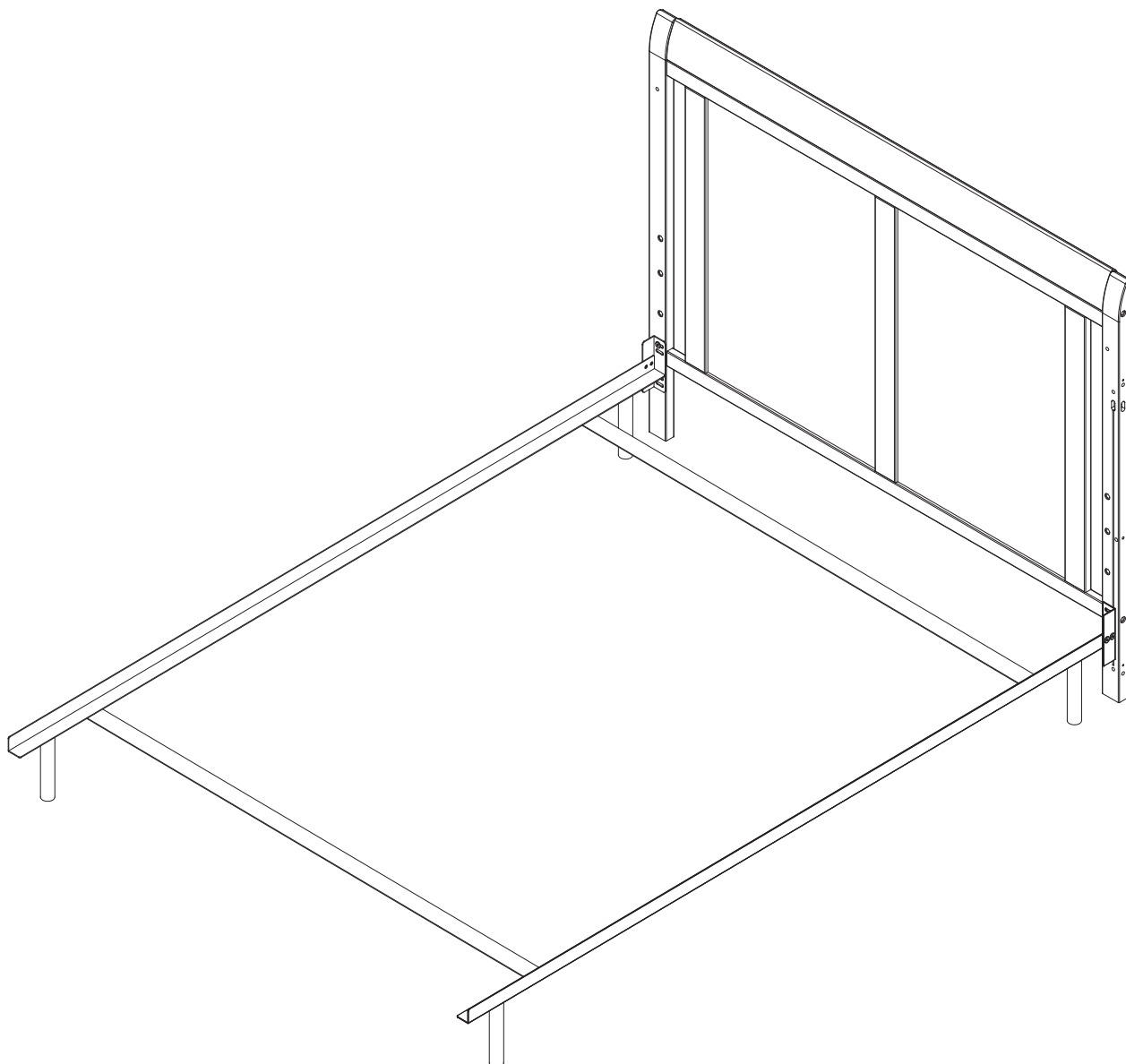



Consumer Care:
www.DeltaChildren.com
Delta Children's Products
114 West 26th Street
New York, NY 10001
Tele.212-645-9033

Warranty: This Delta Crib is warranted to be free from defects for a period of 1 year from the date of purchase under normal use. This warranty extends only to the original retail purchaser and is valid only when supplied with proof of purchase, or if received as a gift, when the registration is on file with Delta.

To register your product for important safety alerts and updates to your product please visit www.DeltaChildren.com

Please do not return this item to the store before contacting us about missing parts or with any questions.

To report a problem, please log on to www.DeltaChildren.com and click the Consumer Care Tab, or contact us by phone at (212) 645-9033.

In the event that you need to contact our customer service department please have the Style Number and Lot Number available. Use the space below to make note of those numbers. They can be found on the label on the Crib End bottom rail.

STYLE No: 74601

COLOR

REV

FTY

Lot No. : _____

Pack Date: _____

Date of Purchase: _____ (you should also keep your receipt)