



Read all instructions before assembly and use.  
**KEEP INSTRUCTIONS FOR FUTURE USE.**

Lisez toutes les instructions avant l'assemblage et l'utilisation.  
**CONSERVEZ LES INSTRUCTIONS POUR UN USAGE ULTERIEUR.**

Lea todas las instrucciones antes de ensamblar y usar.  
**MANTENGA LAS INSTRUCCIONES PARA SU USO FUTURO.**



**Dresser  
Commode  
C6m6da**

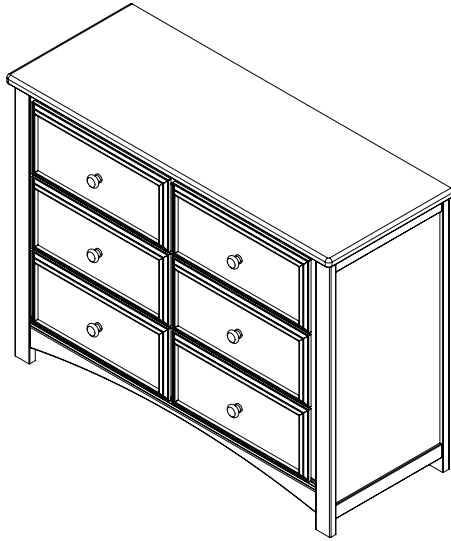

Style #: \_\_\_\_\_  
 [B] Lot: \_\_\_\_\_  
 REV Date: \_\_\_\_\_

**! ADULT ASSEMBLY REQUIRED**  
 Due to the presence of small parts during assembly, keep out of reach of children until assembly is complete.

**! L'ASSEMBLAGE DOIT ETRE FAIT PAR UN ADULTE**  
 A cause de la presence de petites pieces, pendant l'assemblage gardez hors de portee des enfants jusqu'a ce que celui-ci soit termine.

**! DEBE SER ENSAMBLADO POR UN ADULTO**  
 Debido a la presencia de piezas pequenas durante el ensamblaje, mantenga fuera del alcance de los ni6os hasta que complete el ensamblaje.

**This product is not intended for institutional or commercial use.  
 Ce produit ne pas destine a un usage institutionnel ou commercial.  
 Este producto no esta hecho para uso institucional o comercial.**

**NEED EXTRA HELP?**

We make assembly easy with our tips & tricks video  
<https://www.deltachildren.com/pages/instructions>

**BESOIN D'AIDE SUPPL6MENTAIRE?**

Nous facilitons l'assemblage avec nos trucs et astuces vid6o  
<https://www.deltachildren.com/pages/instructions>

**¿NECESITA AYUDA EXTRA?**

Hacemos el montaje f6cil con nuestros consejos y trucos video  
<https://www.deltachildren.com/pages/instructions>

When contacting Delta Consumer Experience Center please reference the above information. Before contacting Delta Consumer Experience Center please ensure that the information above matches the information found on the label on the *Back Panel*, please reference the information found on the product when contacting Delta Consumer Experience Center.

Lorsque vous contactez le Service client de Delta, veuillez faire r6f6rence aux informations ci-dessus. Avant de contacter le Service client de Delta, veuillez vous assurer que les informations ci-dessus correspondent aux informations indiqu6es sur l'6tiquette qui se trouve sur *panneau arri6re*; veuillez faire r6f6rence aux informations indiqu6es sur le produit lorsque vous contactez le Service client de Delta.

Al contactar al servicio al cliente de Delta, entregue la informaci6n anteriormente mencionada. Antes de contactar al servicio de atenci6n al cliente de Delta, aseg6rese de que la informaci6n anteriormente mencionada calza con la que aparece en la etiqueta en *panel trasero*; al contactar al centro de atenci6n al cliente de Delta, mencione la informaci6n que aparece en el producto.

**CONSUMER EXPERIENCE CENTER**

Delta Children's Products Corp | 114 West 26th Street New York, NY 10001  
 (646) 435-8727 | wcs@DeltaChildren.com | www.DeltaChildren.com



# BABY SAFE SLEEP TIPS

Visit [Deltachildren.Com/Pages/Crib-Safety-Tips](https://Deltachildren.Com/Pages/Crib-Safety-Tips) for more information



Read all warnings and follow all instructions.



**DO NOT** place any items in the crib.



The safest place for your baby to sleep is in a JPMA Certified crib.



Pillows and blankets have caused infants to suffocate, **NEVER** use in a crib.

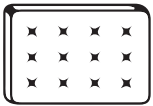

Your baby should sleep on a firm mattress.



**NEVER** place the crib near a window or any wall hangings.



Adult beds are not safe for babies: **NEVER** co-sleep.



Missing or broken parts, any questions? **CALL** Delta Children Consumer Care.



**AAP Recommends:** Always lay your baby on its back to sleep. Consult your doctor.





# FURNITURE SAFETY TIPS

Visit [Deltachildren.Com/Pages/Leaders-In-Safety](https://Deltachildren.Com/Pages/Leaders-In-Safety) for more information

**SERIOUS OR FATAL CRUSHING INJURIES  
CAN OCCUR FROM FURNITURE TIP-OVER.**



Read all warnings and follow all instructions.



**NEVER** open more than one drawer at a time.



**ALWAYS** use provided tipover restraints.



**DO NOT** leave drawers open when not in use.



**DO NOT** set TV's or other heavy objects on the top of bedroom or nursery furniture.



**NEVER** allow children to climb or hang on drawers, doors, or shelves.



Place heaviest items in the lowest drawers.



Missing or broken parts, any questions? **CALL** Delta Children Consumer Care.



# CONSEILS POUR FAIRE DORMIR VOTRE BÉBÉ EN TOUTE SÉCURITÉ

Visitez [Deltachildren.Com/Pages/Crib-Safety-Tips](http://Deltachildren.Com/Pages/Crib-Safety-Tips) pour plus d'information



Lisez tous les avertissements et respectez toutes les consignes de sécurité.



**NE** déposez aucun objet dans le Lit de Bébé



L'endroit le plus sûr pour faire dormir votre bébé, c'est dans un Lit de Bébé approuvé par JPMA.



Des oreillers et couvertures ont parfois été responsables d'étouffements de nourrissons. **N'** en utilisez **JAMAIS** dans un lit de bébé.

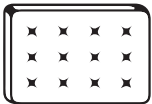

Votre bébé doit dormir sur un matelas ferme.



**NE** placez **JAMAIS** le Lit de Bébé à proximité d'une fenêtre ou de tentures.



Les lits d'adultes ne sont pas un lieu sûr pour les bébés: **NE** dormez **JAMAIS** ensemble.



Des pièces manquantes ou cassées? **APPELEZ** Delta Children Consumer Care.



**Conseils de l'AAP:** Placez toujours votre bébé sur le dos pour dormir. Consultez votre médecin.





# CONSEILS DE SÉCURITÉ RELATIFS AUX MEUBLES

Visitez [Deltachildren.Com/Pages/Leaders-In-Safety](http://Deltachildren.Com/Pages/Leaders-In-Safety) pour plus d'information

## LE RENVERSEMENT DU MEUBLE PEUT ENTRAÎNER DES BLESSURES GRAVES OU MORTELLES.



Lisez tous les avertissements et respectez toutes les consignes de sécurité.



**N'OUVREZ JAMAIS** plus d'un tiroir en même temps



Utilisez **TOUJOURS** les dispositifs de non-renversement fournis.



**NE** laissez **PAS** les tiroirs ouverts lorsque vous ne les utilisez pas.



**NE** déposez **PAS** de postes de télévision ou d'autres objets lourds sur des meubles de chambre à coucher ou de chambre d'enfants.



**NE** laissez **JAMAIS** les enfants monter sur ou se suspendre aux tiroirs, portes et ou tablettes.



Placez les objets les plus lourds dans les tiroirs du bas.



Des pièces manquantes ou cassées? **APPELEZ** Delta Children Consumer Care.



# CONSEJOS PARA UN SUEÑO SEGURO PARA LOS BEBÉS

Visite [Deltachildren.Com/Pages/Crib-Safety-Tips](http://Deltachildren.Com/Pages/Crib-Safety-Tips) para obtener más información



Lea todas las advertencias y siga todas las instrucciones.



**NO** coloque artículos en la cuna.



El lugar más seguro para que su bebé duerma es una cuna con certificación JPMA.



Las almohadas y frazadas han provocado asfixia en menores; por lo tanto, **JAMÁS** se deben utilizar en una cuna.



Su bebé debe dormir sobre un colchón firme.



**NEVER** place the crib near a window or any wall hangings.



Las camas para adultos no son seguras para los bebés: **JAMÁS** duerma con ellos.



¿Le faltan piezas o vienen rotas? **LLAME** al Delta Children Consumer Care.



**APP recomienda:** Haga que su bebé duerma siempre boca arriba. Consulte a su médico.





# CONSEJOS DE SEGURIDAD SOBRE MUEBLES

Visite [Deltachildren.Com/Pages/Leaders-In-Safety](http://Deltachildren.Com/Pages/Leaders-In-Safety) para obtener más información

**PUEDEN PRODUCIRSE LESIONES GRAVES O MORTALES POR  
APLASTAMIENTO AL VOLCARSE MUEBLES.**



Lea todas las advertencias y siga todas las instrucciones.

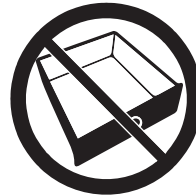

**NUNCA** abra más de un cajón al mismo tiempo.



Utilice **SIEMPRE** las retenciones contra volcamiento incluidas



**NO DEJE** cajones abiertos si no los está utilizando.



**NO** posicione televisores u otros objetos pesados sobre la cama o muebles para infantes.



**NUNCA** permita que los niños trepen sobre cajones, puertas o baldas de estantería ni que se cuelguen de ellos.



Coloque los artículos de mayor peso en los cajones inferiores.



¿Le faltan piezas o vienen rotas? **LLAME** al Delta Children Consumer Care.



# SAVE BIG WITH DELTA CHILDREN

Visit [Deltachildren.com](http://Deltachildren.com) To Start Shopping

Welcome to the  
**DELTA FAMILY**  
Here's a Gift From Us To You

# 10% OFF

Your Next Purchase From  
[DeltaChildren.com](http://DeltaChildren.com)

USE CODE:  
**DELTA10**

\*Exclusions Apply  
\*Subject to Change

## REVIEW TO WIN \$2500

### RULES TO ENTER



*"We LOVE, LOVE, LOVE this crib"*

My husband was impressed with the directions and organization of the hardware package. He easily assembled this crib in an hour without any help. It's very sturdy and we like that it has adjustable levels for the mattress height. To top it all off, it's so incredibly darling!!!

- 1** **WRITE A REVIEW** for this product on the store's website from where it was purchased
- 2** **TAKE A SCREENSHOT** of your review and upload it to [www.DeltaChildren.com/Review](http://www.DeltaChildren.com/Review)
- 3** **IT'S THAT EASY!** Upon submission, you'll be instantly **ENTERED TO WIN \$2,500**

#### FOLLOW US FOR MORE CHANCES TO WIN



@deltachildren

#### SCAN HERE



For more  
information &  
to see all of  
our products







# ÉCONOMISEZ BEAUCOUP AVEC AHORRE MUCHO CON DELTA CHILDREN

Visitez [Deltachildren.com](http://Deltachildren.com) Pour Commencer Vos Achats  
Visita [Deltachildren.com](http://Deltachildren.com) Para Comenzar A Comprar

Bienvenue dans la  
**FAMILLE DELTA**  
Voici Notre Cadeau Pour Vous  
Bienvenido a la  
**FAMILIA DELTA**  
Aquí Está Nuestro Regalo Para Usted

# 10% OFF

Votre Prochain Achat Chez  
Su Próxima Compra En  
[DeltaChildren.com](http://DeltaChildren.com)

UTILISEZ LE CODE:  
UTILICE EL CÓDIGO:  
**DELTA10**

\*Des exclusions s'appliquent  
\*Sujet à changement

\*Exclusions Apply  
\*Subject to Change

LAISSEZ UN COMMENTAIRE CLIENT POUR **GAGNER \$2500**  
CALIFIQUE EL PRODUCTO PARA **GANAR \$2500**

## REGLEMENT DE PARTICIPATION / REGLAS PARA PARTICIPAR

- 1** ECRIVEZ UN COMMENTAIRE CLIENT pour ce produit sur le site web du magasin où il a été acheté  
CALIFIQUE EL PRODUCTO en la página web de la tienda donde haya sido comprado
- 2** FAITES UNE CAPTURE D'ECRAN de votre commentaire client et mettez la en ligne sur [www.DeltaChildren.com/Review](http://www.DeltaChildren.com/Review)  
HAGA UNA CAPTURA DE PANTALLA de su calificación y cárguela a la pagina [www.DeltaChildren.com/Review](http://www.DeltaChildren.com/Review)
- 3** C'EST AUSSI SIMPLE QUE ÇA! Dès que c'est fait vous serez instantanément **INSCRIT POUR GAGNER 2500\$**  
ES ASÍ DE FÁCIL! En cuanto lo envíe ya estará instantáneamente **PARTICIPANDO PARA GANAR \$2.500**

SUIVEZ NOUS POUR AVOIR PLUS DE CHANCES DE GAGNER /  
SÍGANOS PARA TENER MAS CHANCES DE GANAR



@deltachildren

SCANNEZ ICI / ESCANEE AQUÍ



Pour plus d'informations et  
pour voir tous nos produits

Para más información y para  
ver todos nuestros productos



## **⚠ WARNING**



**Children have died from furniture tipover. To reduce the risk of furniture tipover:**

- ALWAYS install tipover restraint provided.
- NEVER put a TV on this product.
- NEVER allow children to stand, climb or hang on drawers, doors, or shelves.
- NEVER open more than one drawer at a time.
- Place heaviest items in the lowest drawers.



## **⚠ AVERTISSEMENT**



**Des enfants sont morts à cause d'un meuble qui se renverse. Pour aider à prévenir un renversement :**

- Installez TOUJOURS le système anti-bascule fourni.
- Ne JAMAIS placer un téléviseur sur ce produit.
- Ne jamais permettre à un enfant de grimper ou s'accrocher aux tiroirs, portes ou étagères.
- Ne jamais ouvrir plus d'un tiroir a la fois
- Placez les articles les plus lourds dans les tiroirs inferieurs.



## **⚠ ADVERTENCIA**



**Han muerto niños debido a volcaduras de muebles. Para prevenir volcaduras:**

- Instalar SIEMPRE el dispositivo anti-volcaduras incluido.
- No colocar NUNCA un televisor en este producto.
- Nunca permita que los niños trepen sobre cajones, puertas o baldas de estantería ni que se cuelguen de ellos.
- Nunca abra más de un cajón al mismo tiempo.
- Coloque los artículos de mayor peso en los cajones inferiores.



#### NOTES ON ASSEMBLY:

-During the assembly process whenever using screws or bolts, check each by placing the screw/bolt on the diagram of the item which is drawn actual size and design. Be sure to use the proper size and shape specified in the instructions.

-To assemble this unit you may be required to place the unit on it's side and face. It is strongly recommended that assembly is done on a soft, non-abrasive surface to avoid damaging the finish.

#### NOTES ON CARE AND MAINTENANCE:

- **Do not** scratch or chip the finish.

- Inspect the product periodically, contact Delta Children's Products for replacement parts or questions.

- **Do not** store the product or any parts in extreme temperatures and conditions such as a hot attic or a damp, cold basement. These extremes can cause a loss of structural integrity.

-To preserve the luster of the high quality finish on your product, it is recommended to place a doily or felt pad under any items you place on the finish.

-Clean with a damp cloth, then a dry cloth to preserve the original luster and beauty of this fine finish.

-**Do not** use abrasive chemicals.

-**Do not** spray cleaners directly onto furniture.

-Lift slightly when moving on carpeting to prevent leg breakage.

-Use of a vaporizer near furniture will cause wood to swell and finish to peel.

---

#### REMARQUES SUR L'ASSEMBLAGE :

-Lors de l'assemblage, quand vous utilisez vis ou boulons, vérifiez chaque pièce en plaçant le vis/boulon sur le diagramme de la pièce concernée qui est dessinée en taille et forme réelle. Assurez-vous d'utiliser la taille et la forme exacte comme il est spécifié dans les instructions.

-Pour assembler cet élément vous pourriez avoir besoin de le placer sur le côté latéral et sur le côté frontal. Il est fortement recommandé de faire l'assemblage sur une surface lisse, non abrasive (comme le film mousse de l'emballage) pour éviter d'endommager les finitions.

#### REMARQUES SUR LE SOIN ET L'ENTRETIEN:

-**Ne pas** rayer ou ébrécher la finition.

-Examinez de près le produit régulièrement, contactez Delta Children's Products pour les pièces de rechange ou pour poser des questions.

-**Ne pas** ranger le produit ou des pièces à des températures extrêmes ou dans des conditions comme un grenier chaud ou une cave froide et humide. Ces extrêmes peuvent causer une perte de l'intégrité de la structure du produit

-Pour préserver le lustre original et la beauté de ce fini raffiné nettoyer avec un chiffon humide, puis un chiffon sec.

-**Ne pas** utiliser des produits chimiques abrasifs

-**Ne pas** pulvériser un nettoyant directement sur le meuble, pulvériser sur le torchon et puis appliquer sur le meuble. Testez le produit nettoyant sur un endroit discret avant de l'utiliser sur la totalité du meuble

-Lors d'un déplacement sur une moquette ou tapis, soulevez légèrement le meuble pour éviter de casser les pieds.

-L'utilisation d'un vaporisateur près du meuble causera le gonflement du bois et l'écaillage de la finition.

---

#### INFORMACIÓN SOBRE EL MONTAJE:

-Durante el proceso de montaje, ya utilice pernos o tornillos, compruebe cada uno de ellos colocando el perno/tornillo en el diagrama del artículo donde está dibujado el tamaño y el diseño real. Asegúrese de que utiliza el tamaño y la forma adecuada que especifican las instrucciones.

-Para montar esta unidad, puede que se le solicite que coloque la unidad de lado y de cara. Se recomienda encarecidamente que realice el montaje sobre una superficie no abrasiva (Como la envoltura de embalaje de espuma) para evitar dañar el acabado.

#### NOTAS SOBRE SU CUIDADO Y MANTENIMIENTO:

- **No** arañe ni desconche el acabado.

- Inspeccione el producto con regularidad, póngase en contacto con Delta Children's Products para el recambio de partes o para formular preguntas.

- **No** guarde el producto ni ninguna de sus partes a temperaturas ni en condiciones extremas como un ático caluroso o un sótano húmedo y frío. Estos extremos pueden provocar una pérdida de integridad estructural.

-Para preservar el brillo del acabado de alta calidad que recubre su producto, se recomienda que coloque un paño o una almohadilla de fieltro debajo de cualquier objeto que coloque sobre el acabado.

-Límpielo con un trapo húmedo y luego con uno seco para preservar el brillo y la belleza originales de este fino acabado.

-**No** utilice productos químicos abrasivos.

-**No** pulverice limpiadores directamente sobre el mueble.

-Elévelo ligeramente cuando lo mueva sobre alfombras o moqueta para evitar que se rompan las patas.

-El uso de vaporizadores cerca de muebles puede provocar que la madera se hinche y acabe desconchándose.



PARTS: MAKE SURE THAT ALL PRE-ASSEMBLED PARTS ARE TIGHT  
 PIÈCES : VÉRIFIEZ QUE TOUTES LES PIÈCES PRÉ-MONTÉES SONT BIEN SERRÉES.  
 PIEZAS: ASEGÚRESE DE QUE TODAS LAS PIEZAS PRE-ENSAMBLADAS ESTÁN BIEN APRETADAS.

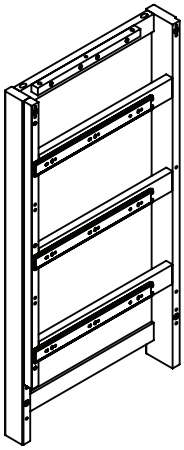

A. Left Side x1  
Côté gauche  
Lado izquierdo  
# 29619

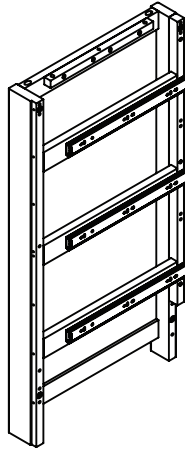

B. Right Side x1  
Côté droit  
Lado derecho  
# 29620

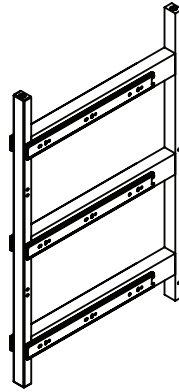

R. Center Panel x1  
Panneau central  
Panel central  
# 29621

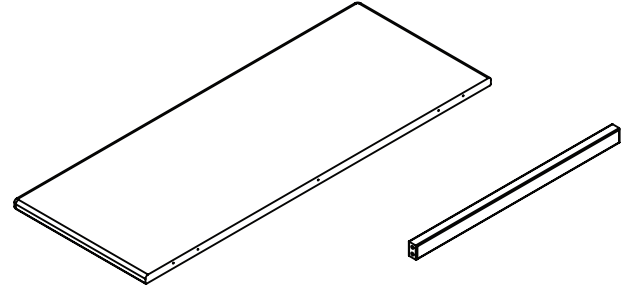

G. Top Panel x1  
Panneau supérieur  
Panel superior  
#29628

F. Drawer Rail x4  
Barre de tiroir  
Barra de la gaveta  
#29626

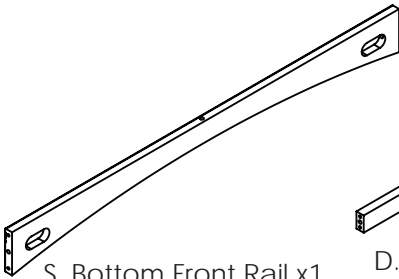

S. Bottom Front Rail x1  
Barre avant inférieur  
Barra frontal inferior  
# 29624

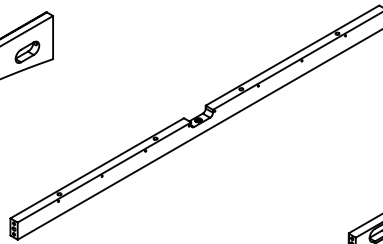

D. Top Back Rail x1  
Barre arrière supérieur  
Barra trasero superior  
# 29623

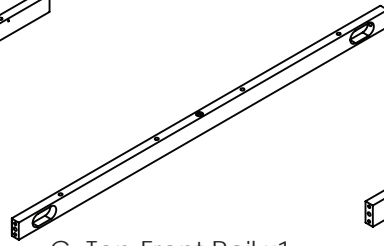

C. Top Front Rail x1  
Barre avant supérieur  
Barra frontal superior  
# 29622

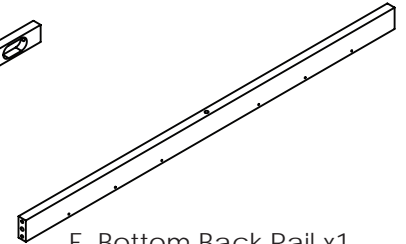

E. Bottom Back Rail x1  
Barre arrière inférieur  
Barra trasero inferior  
# 29625

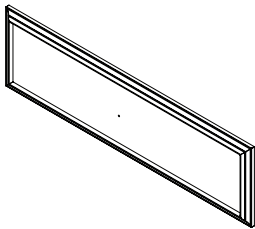

K. Drawer Front x6  
Avant du tiroir  
Parte frontal de la gaveta  
#29631

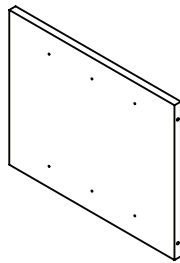

T. Back Weight x2  
Poids arrière  
Peso trasero  
# 29627

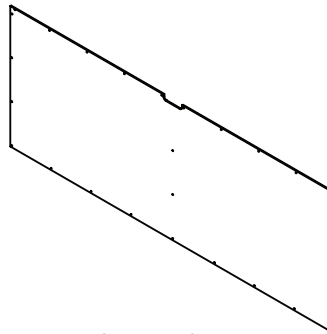

H. Back Panel-Upper x1  
Panneau arrière - Supérieur  
Panel Trasero Superior  
#29629

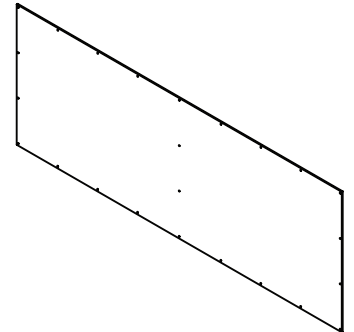

J. Back Panel-Lower x1  
Panneau arrière - Inférieur  
Panel Inferior Trasero  
#29630

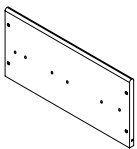

L. Drawer Side x12  
Barre de tiroir  
Barra de la gaveta  
# 29632

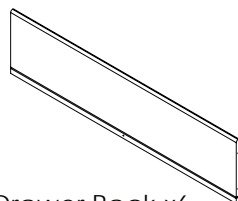

M. Drawer Back x6  
Arrière du tiroir  
Trasera de la gaveta  
#29633

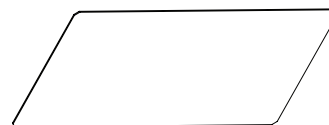

N. Drawer Bottom x6  
Fond du tiroir  
Fondo de la gaveta  
# 29634



P. Drawer Support x6  
Support du Tiroir  
Soporte de la Gaveta  
# 29635





Parts: Hardware kits part#29758

Pièces: L'ensemble de quincaillerie - pièce n°29758

Piezas: El kit de herramientas - Pieza #29758

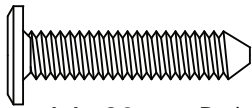
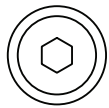
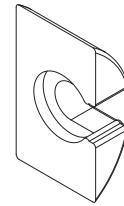

AA. 30mm Bolt x5  
Boulon 30mm  
Perno 30mm

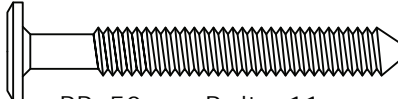
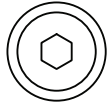

BB. 50mm Bolt x 11  
Boulon 50mm  
Perno 50mm

DD. Crescent Washer x8  
Rondelle en croissant  
Arandela de media luna

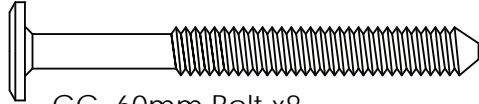
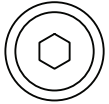

CC. 60mm Bolt x8  
Boulon 60mm  
Perno 60mm

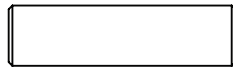

JJ.  $\Phi$ 8x30mm Dowel x42  
Cheville  $\Phi$ 8x30mm  
Pasador  $\Phi$ 8x30mm



LL. Plastic Barrel Nut x30  
Écrou à portée cylindrique  
en plastique  
Tuercacilindricaplástica

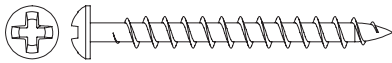

GG. 40mm Screw x30  
Vis 40mm  
Tornillo 40mm



KK. 12mm Screw x36  
Vis 12mm  
Tornillo 12mm

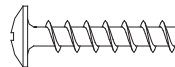

EE. 20mm Screw x24  
Vis 20mm  
Tornillo 20mm

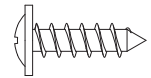

FF. Back Panel Screw x46  
Vis pour Panneau Arrière  
Tornillo de Panel Trasero

PP. Knob / Bouton / Perilla x6  
#24983



PP2. Knob Screw  
Vis de Bouton  
Tornillo para Perilla

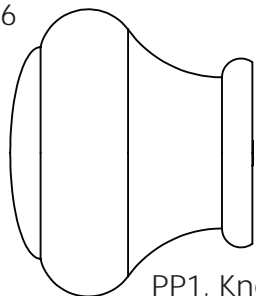

PP1. Knob  
Bouton  
Perilla

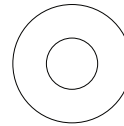

TT. Washer x2  
Rondelle  
Arandela

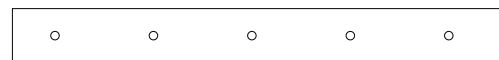

ZZ. (1) Wall Strap/Sangle murale/Abrazadera

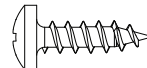

YY. Short Screw x1  
Vis Court  
Tornillo corto

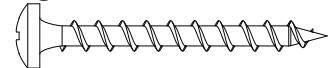

XX. Long Screw x1  
Vis Longue  
Tornillo Largo

**CAUTION: Do Not use a power screwdriver they can cause screws to break or strip.**

**ATTENTION: Ne Pas utiliser un tournevis électrique car les vis peuvent casser ou perdre leurs filets.**

**ATENCIÓN: No use un destornillador eléctrico ya que puede causar que los**

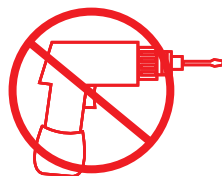

M4 Allen Wrench (included)  
Clé Allen M4 (inclus)  
Llave Allen M4 (incluido)

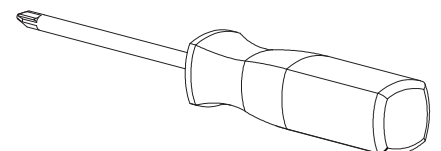

Phillips Screwdriver – Not included  
Tournevis Phillips - non inclus  
Destornillador Phillips – no incluido

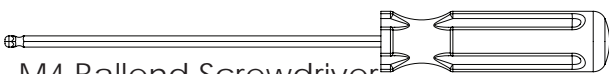

M4 Ballend Screwdriver  
tournevis M4 à tête sphérique  
destornillador M4 con cabeza de bola





**Hardware System - Review Before Assembly**  
**Quincaillerie – Lire Avant D’effectuer Le Montage**  
**Revise Antes De Armar- Elementos De Fijacion Y Ensamble**

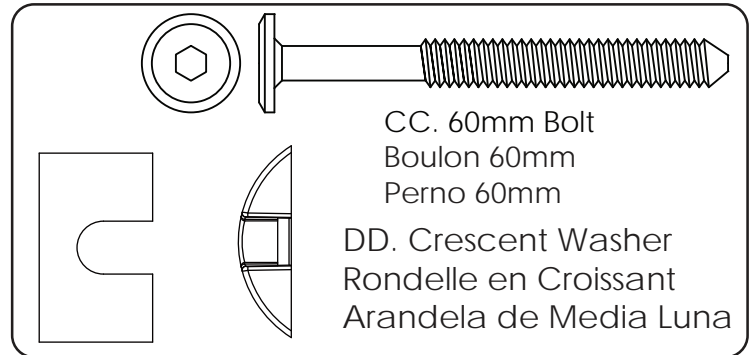
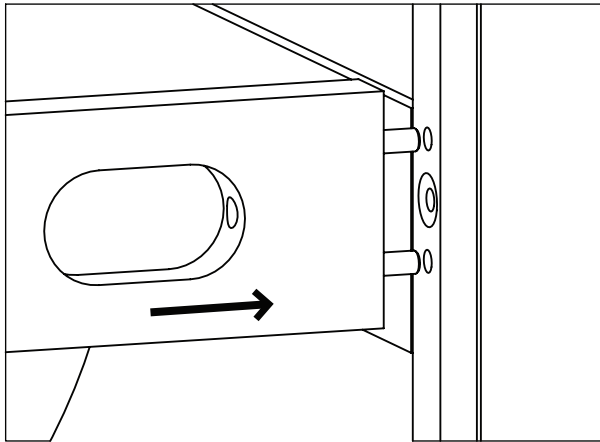

1. Insert the Dowels in the Rail into the holes in the Post.
1. Insérer les chevilles dans le rail dans les orifices dans le poteau.
1. Inserte los pasadores del Riel en los agujeros del Poste.

2. Insert the Bolt into the slot. Turn clockwise with fingers or the Ball End Screwdriver provided. DO NOT fully tighten, leave 1/2" (12mm) exposed.

2. Insérez le boulon dans la fente. Tournez dans le sens des aiguilles d’une montre à l’aide des doigts ou de la tournevis à tête sphérique. Ne Pas serrer complètement et laissez 12 mm (1/2 pouces) exposés.

2. Inserte el perno en la ranura. Gírelo en el sentido de las agujas del reloj con los dedos o con el destornillador con cabeza de bola. NO lo apriete del todo, deje 1/2" (12 mm) fuera.

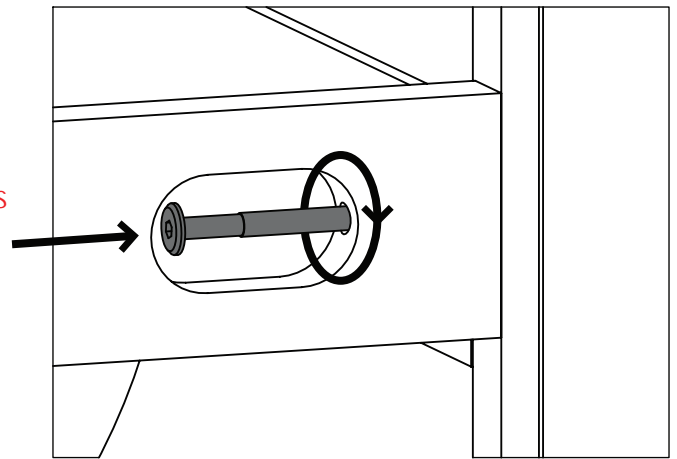

3. Slide the Crescent Washer over the exposed bolt, behind the head of the bolt.

3. Glissez la rondelle en croissant sur l’écrou exposé, derrière la tête de l’écrou.

3. Abrace la parte del Perno que quedó fuera, debajo de la cabeza del mismo, con la Arandela de media luna.

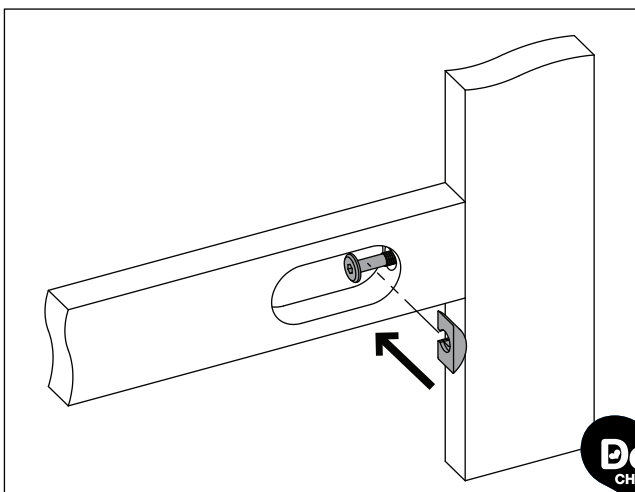



Install (1) bolt and (1) crescent washer at a time. Tighten until it looks like the picture.

Installez (1) boulon et (1) rondelle en croissant à la fois. Serrez jusqu'à ce que cela ressemble à l'image.

Instale (1) perno y (1) Arandela de media luna al mismo tiempo. Apriételos hasta que quede como en la ilustración.

Tighten the bolt with the ball end screwdriver.  
Serrez à l'aide de la Tournevis à tête sphérique.  
Apriételo con el Destornillador hcon cabeza de bola.

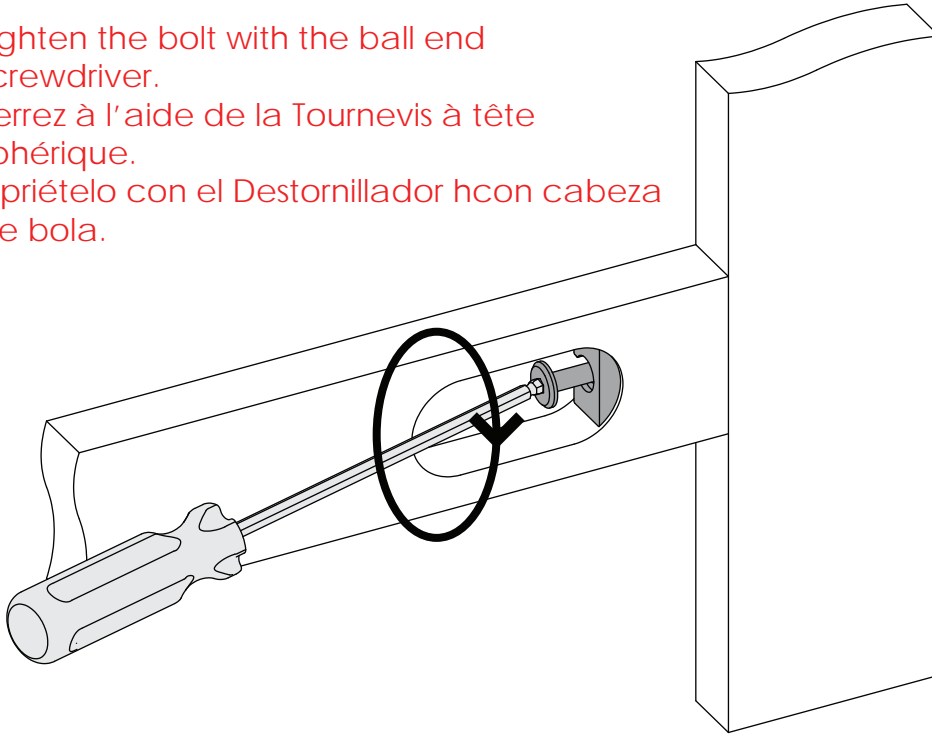

Ensure all bolts are tight with Allen wrench.  
Serrez à l'aide de la clé Allen.  
Apriételo con la llave Allen.

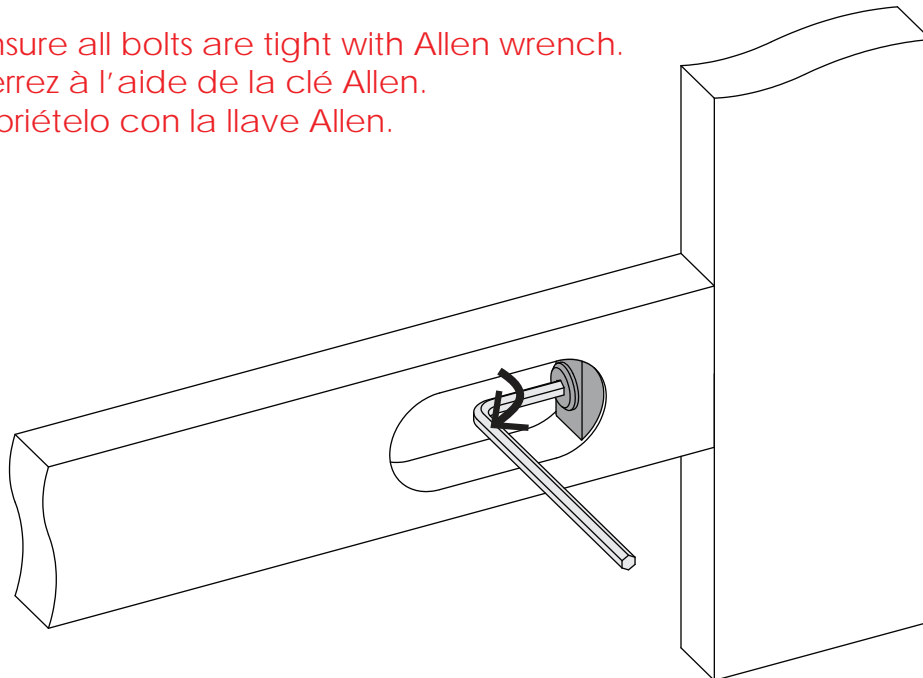



Step 1  
Étape 1  
Paso 1

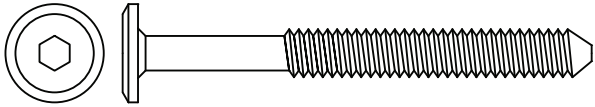

CC. 60mm Bolt x4  
Boulon 60mm  
Perno 60mm

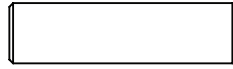

JJ.  $\Phi$ 8x30mm Dowel x8  
Cheville  $\Phi$ 8x30mm  
Pasador  $\Phi$ 8x30mm



DD. Crescent Washer x4  
Rondelle en croissant  
Arandela de media luna



M4 Allen Wrench  
Clé Allen M4  
Llave Allen M4



M4 Ballend Screwdriver  
tournevis M4 à tête sphérique  
destornillador M4 con cabeza de bola

Attach Bottom Front Rail (Part S), Bottom Back Rail (Part E), Top Front Rail (Part C) and Top Back Rail (Part D) to Left Side (Part A) using (4) 60mm bolts (Part CC), (4) Crescent Washer (Part DD) and (8)  $\Phi$ 8x30mm Dowels (Part JJ). Tighten the Bolts with the M4 Ballend Screwdriver and M4 Allen wrench, following the instructions on pages 14 and 15.

Fixer le Barre avant inférieur (Pièce S), Barre arrière inférieur (Pièce E), Barre Supérieur avant (Pièce CC) et Barre Supérieur Arrière (Pièce D) au Côté gauche (Pièce A) à l'aide de (4) boulons de 60 mm (Pièce CC), (4) Rondelle en croissant (Pièce DD) et (8) Chevilles  $\Phi$ 8x30mm (Pièce JJ) à l'aide de dutournevis M4 à tête sphériqueet la clé Allen M4 ensuivant les instructions pages 14 et 15.

Fije la Barra frontal inferior (Pieza S), Barra trasero inferior (Pieza E), Barra Frontal Superior (Pieza C) y Barra Posterior Superior (Pieza D) al Lado izquierdo (Pieza A) utilizando (4) Pernos 60mm (Pieza CC), (4) Arandela de media luna (Pieza DD) y (8) Pasadores  $\Phi$  8x30mm (Pieza JJ) utilizando el destornillador M4 con cabeza de bola y la llave Allen M4 siguiendo las instrucciones de las páginas 14 y 15.





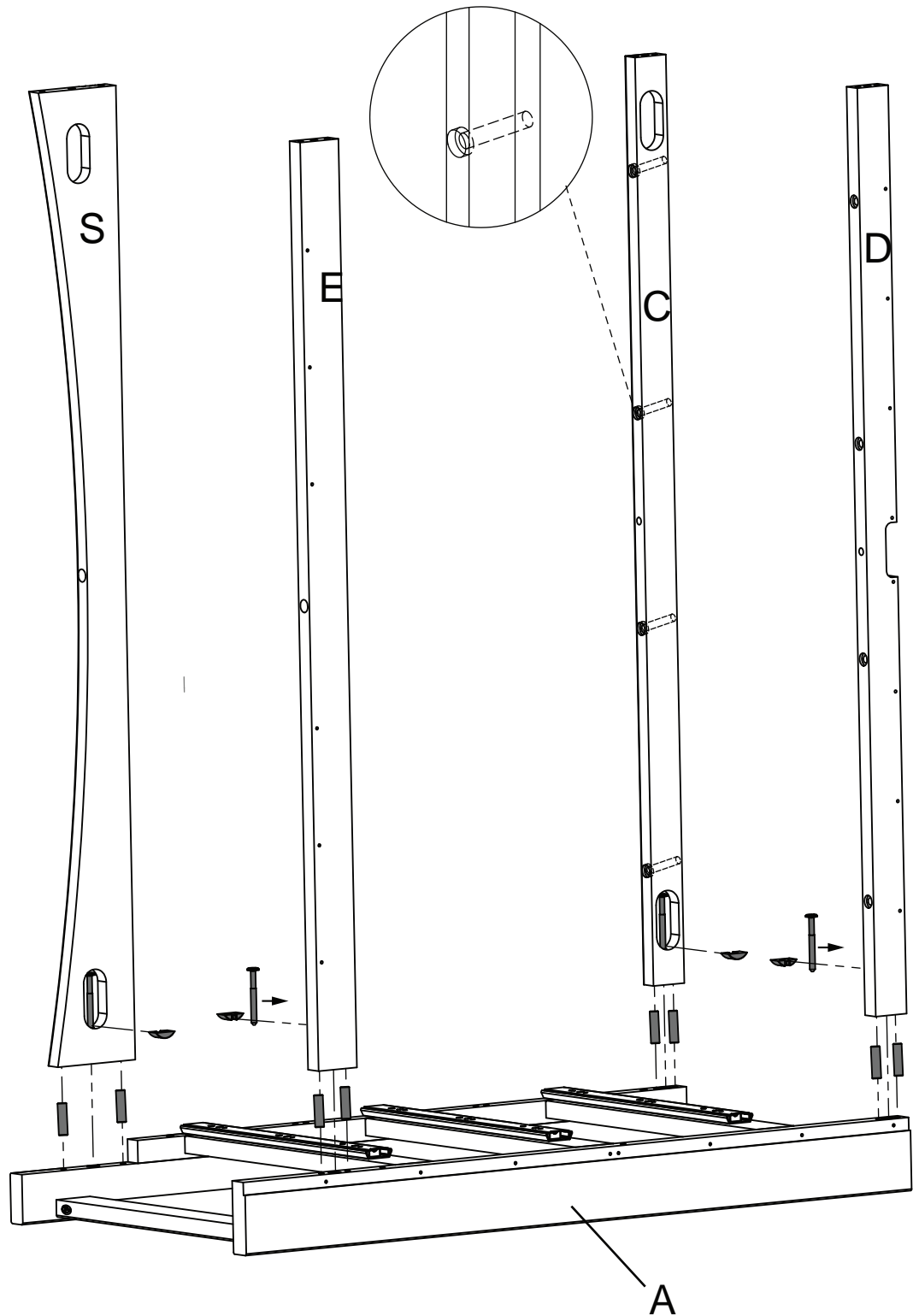
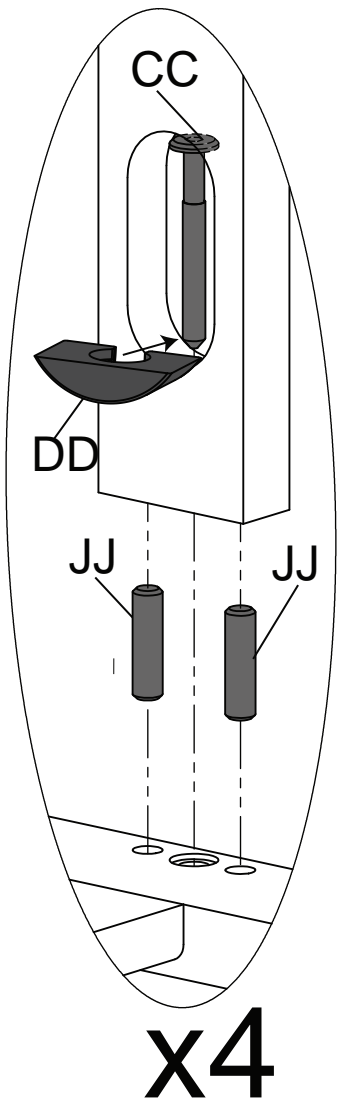



Step 2  
Étape 2  
Paso 2

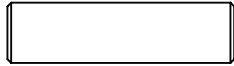

JJ.  $\Phi$ 8x30mm Dowel x6  
Cheville  $\Phi$ 8x30mm  
Pasador  $\Phi$ 8x30mm

Attach (2) Drawer Rails (Part F) and (1) Back Weight ( Part T) to the assembly from Step 1 using (6)  $\Phi$ 8x30mm Dowels (Part JJ).

Fixez le Barre de tiroir (pièce F) et (1) Poids arrière (pièce T) au montage réalisé à l'étape 1 à l'aide de (6) Chevilles  $\Phi$ 8x30mm (Pièce JJ).

Fije el Barra de la gaveta (Pieza F) y (1) Peso trasero (Pieza T) al ensamblaje del Paso 1 utilizando (6) Pasadors  $\Phi$ 8x30mm (Pieza JJ) .



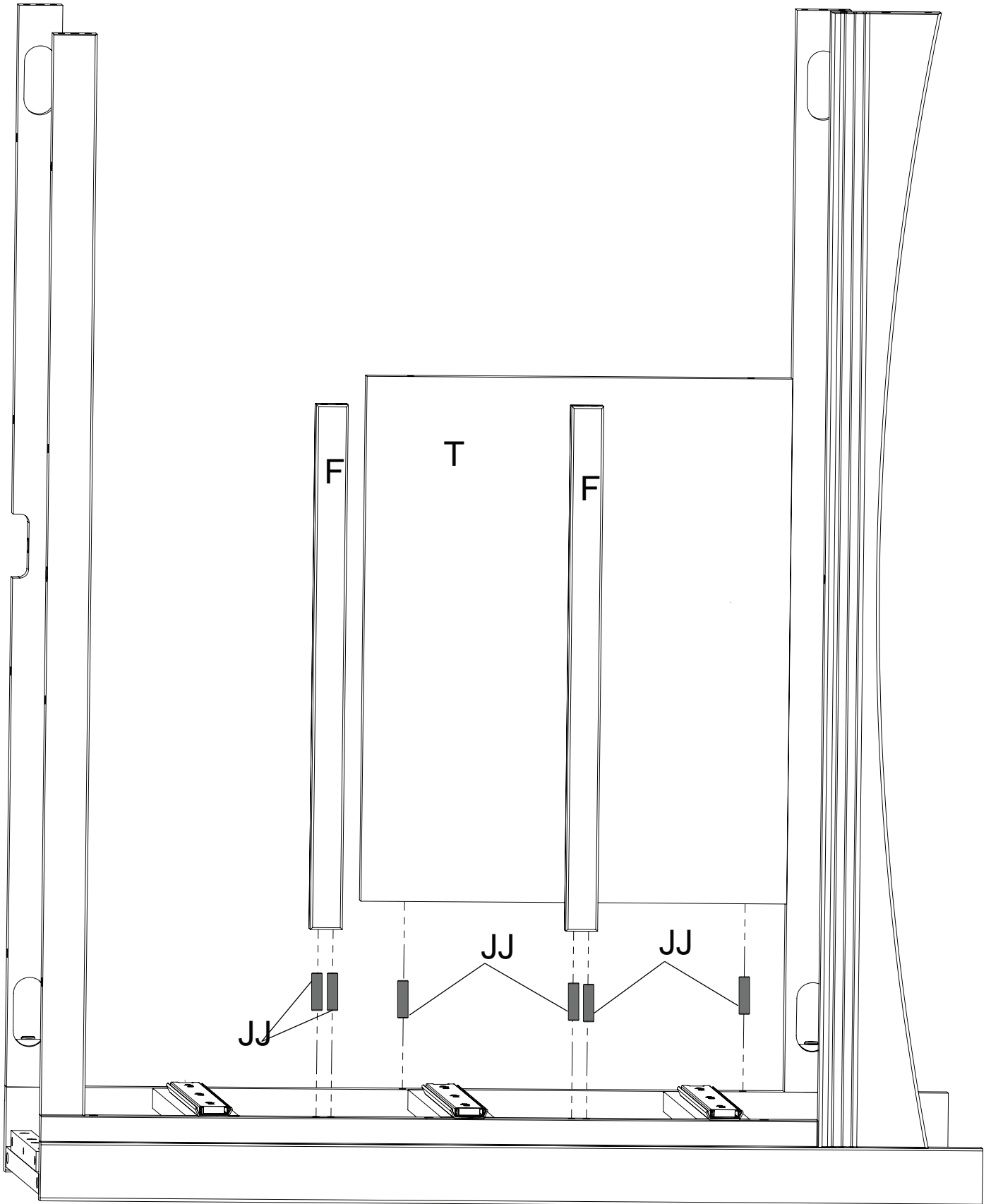



Step 3  
Étape 3  
Paso 3

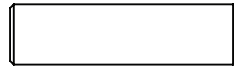

JJ.  $\Phi$ 8x30mm Dowel x6  
Cheville  $\Phi$ 8x30mm  
Pasador  $\Phi$ 8x30mm

Attach the Center Panel (Part R) to the assembly from Step 2 using (6)  $\Phi$ 8x30mm Dowels (Part JJ).

Fixez le Panneau central (pièce R) au montage réalisé à l'étape 2 à l'aide de (6) Chevilles  $\Phi$ 8x30mm (Pièce JJ).

Fije el Panel central (Pieza R) al ensamblaje del Paso 2 utilizando (6) Pasadores  $\Phi$ 8x30mm (Pieza JJ) .



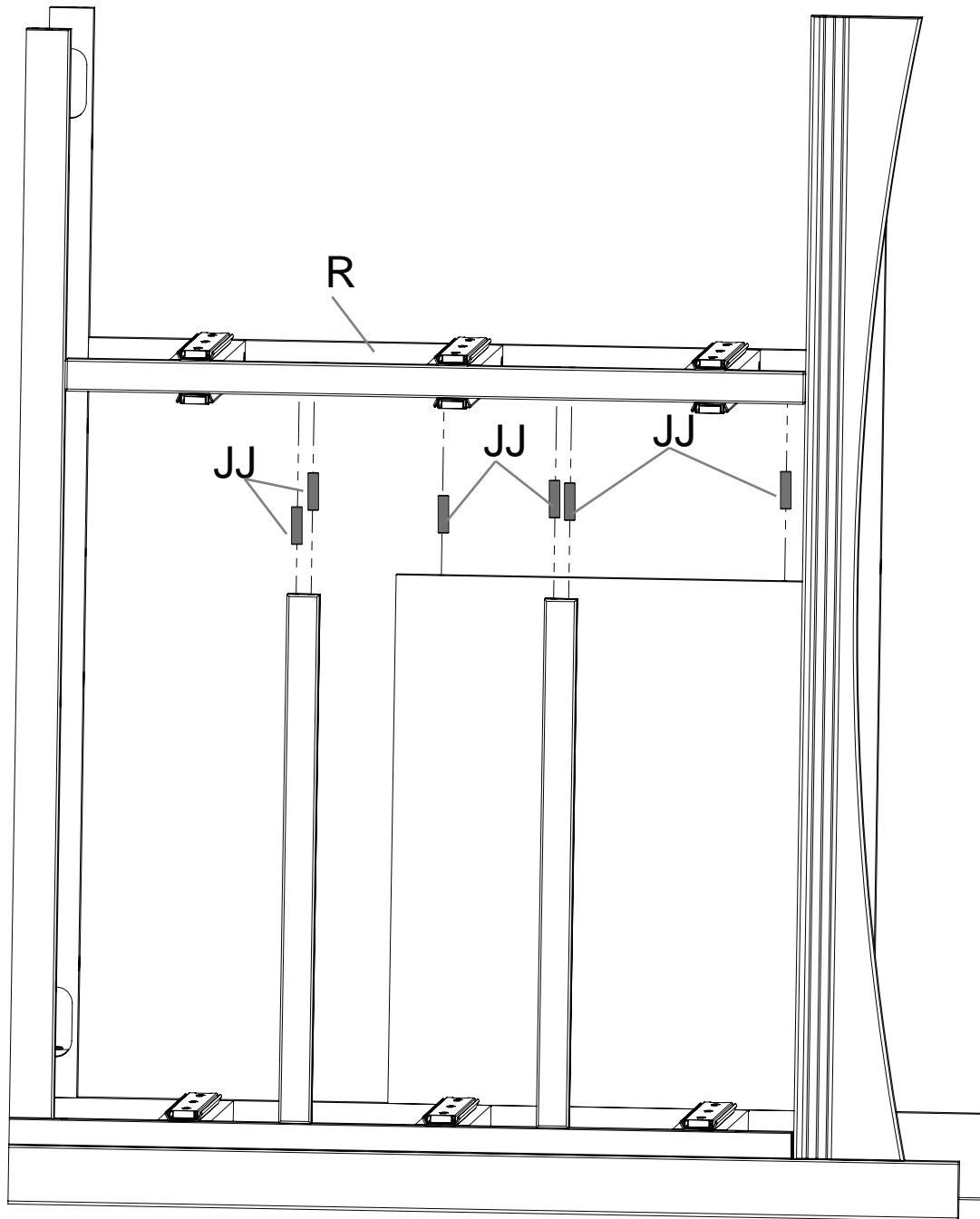



Step 4  
Étape 4  
Paso 4

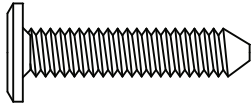
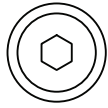

AA. 30mm Bolt x1  
Boulon 30mm  
Perno 30mm

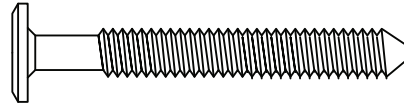
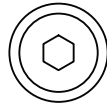

BB. 50mm Bolt x 3  
Boulon 50mm  
Perno 50mm

Attach the Center Panel (Part R) to the assembly from Step 2 using (1) 30mm Bolt (Part AA) and (3) 50mm Bolts (Part BB). Tighten the Bolts with the M4 Ballend Screwdriver and M4 Allen wrench.

Fixez le Panneau central (pièce R) au montage réalisé à l'étape 2 à l'aide de (1) Boulon 30 mm (Pièce AA) et (3) Boulons 50 mm (Pièce BB) à l'aide de du tournevis M4 à tête sphérique et la clé Allen M4.

Fije el Panel central (Pieza R) al ensamblaje del Paso 2 utilizando (1) Pernos 30 mm (Pieza AA) y (3) Pernos 50 mm (Pieza BB) utilizando el destornillador M4 con cabeza de bola y la llave Allen M4.



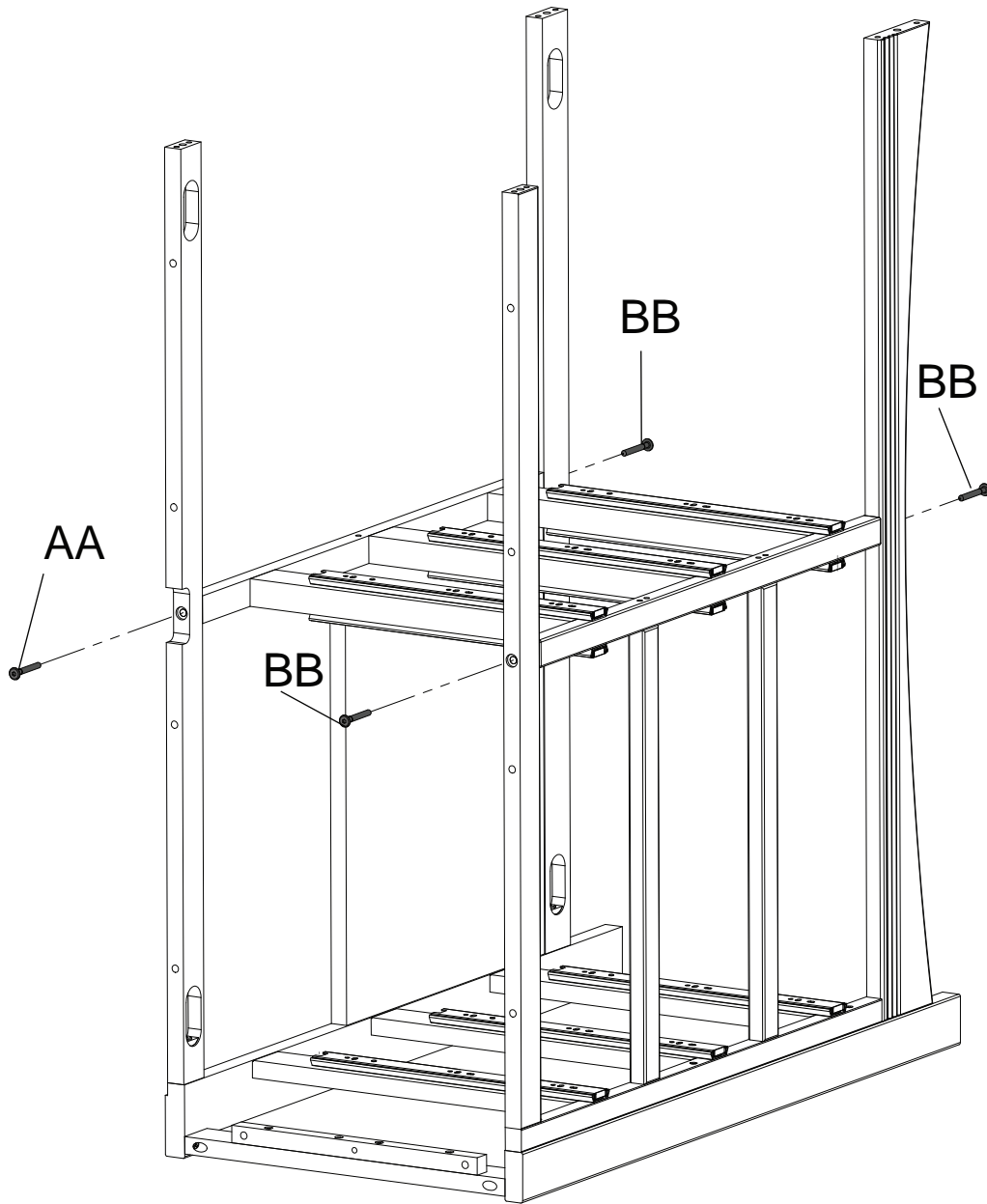



Step 5  
Étape 5  
Paso 5

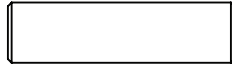

JJ.  $\Phi$ 8x30mm Dowel x6  
Cheville  $\Phi$ 8x30mm  
Pasador  $\Phi$ 8x30mm

Attach (2) Drawer Rails (Part F) and (1) Back Weight ( Part T) to the assembly from Step 4 using (6)  $\Phi$ 8x30mm Dowels (Part JJ).

Fixez le Barre de tiroir (pièce F) et (1) Poids arrière (pièce T) au montage réalisé à l'étape 4 à l'aide de (6) Chevilles  $\Phi$ 8x30mm (Pièce JJ).

Fije el Barra de la gaveta (Pieza F) y (1) Peso trasero (Pieza T) al ensamblaje del Paso 4 utilizando (6) Pasadors  $\Phi$ 8x30mm (Pieza JJ) .





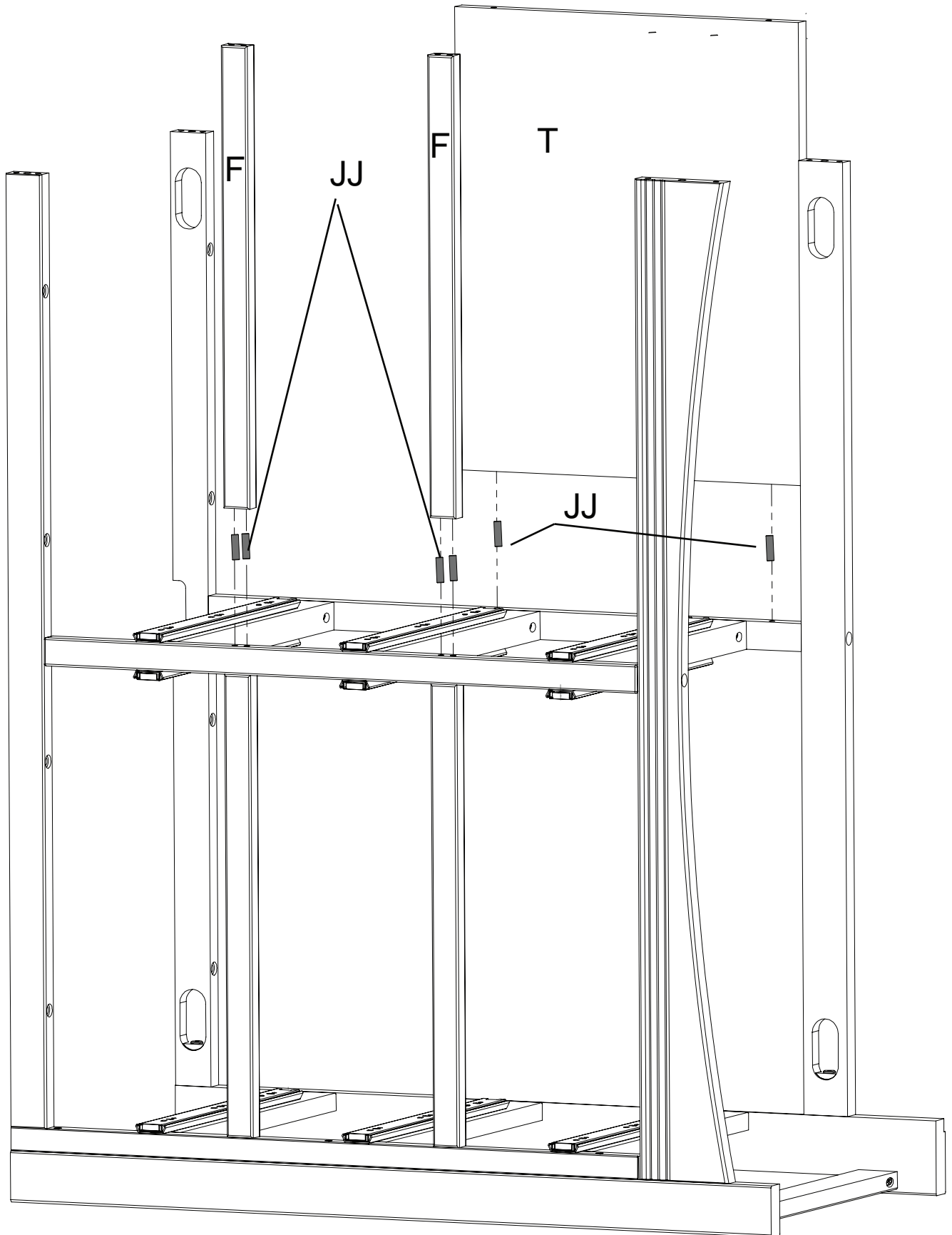



Step 6  
Étape 6  
Paso 6

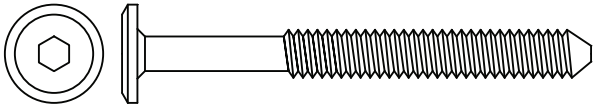

CC. 60mm Bolt x4  
Boulon 60mm  
Perno 60mm

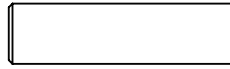

JJ.  $\Phi$ 8x30mm Dowel x14  
Cheville  $\Phi$ 8x30mm  
Pasador  $\Phi$ 8x30mm



DD. Crescent Washer x4  
Rondelle en croissant  
Arandela de media luna



M4 Allen Wrench  
Clé Allen M4  
Llave Allen M4



M4 Ballend Screwdriver  
tournevis M4 à tête sphérique  
destornillador M4 con cabeza de bola

Attach the Right Side (Part B) to the assembly from Step 5 using (4) 60mm bolts (Part CC), (4) Crescent Washer (Part DD) and (14)  $\Phi$ 8x30mm Dowels (Part JJ). Tighten the Bolts with the M4 Ballend Screwdriver and M4 Allen wrench, following the instructions on pages 14 and 15.

Fixez le côté droit (pièce B) au montage réalisé à l'étape 5 à l'aide de (4) boulons de 60 mm (Pièce CC), (4) Rondelle en croissant (Pièce DD) et (14) Chevilles  $\Phi$ 8x30mm (Pièce JJ) à l'aide de tournevis M4 à tête sphérique et la clé Allen M4 ensuivant les instructions pages 14 et 15.

Fije el lado derecho (Pieza B) al ensamblaje del Paso 5 utilizando (4) Pernos 60mm (Pieza CC), (4) Arandela de media luna (Pieza DD) y (14) Pasadors  $\Phi$ 8x30mm (Pieza JJ) utilizando el destornillador M4 con cabeza de bola y la llave Allen M4 siguiendo las instrucciones de las páginas 14 y 15.

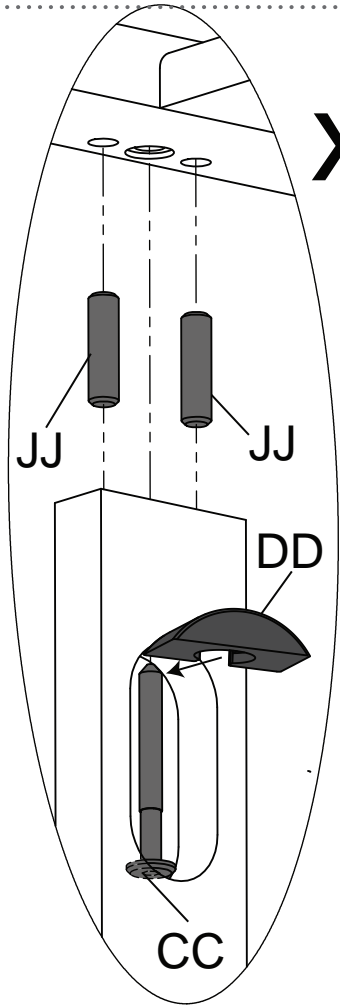

x4

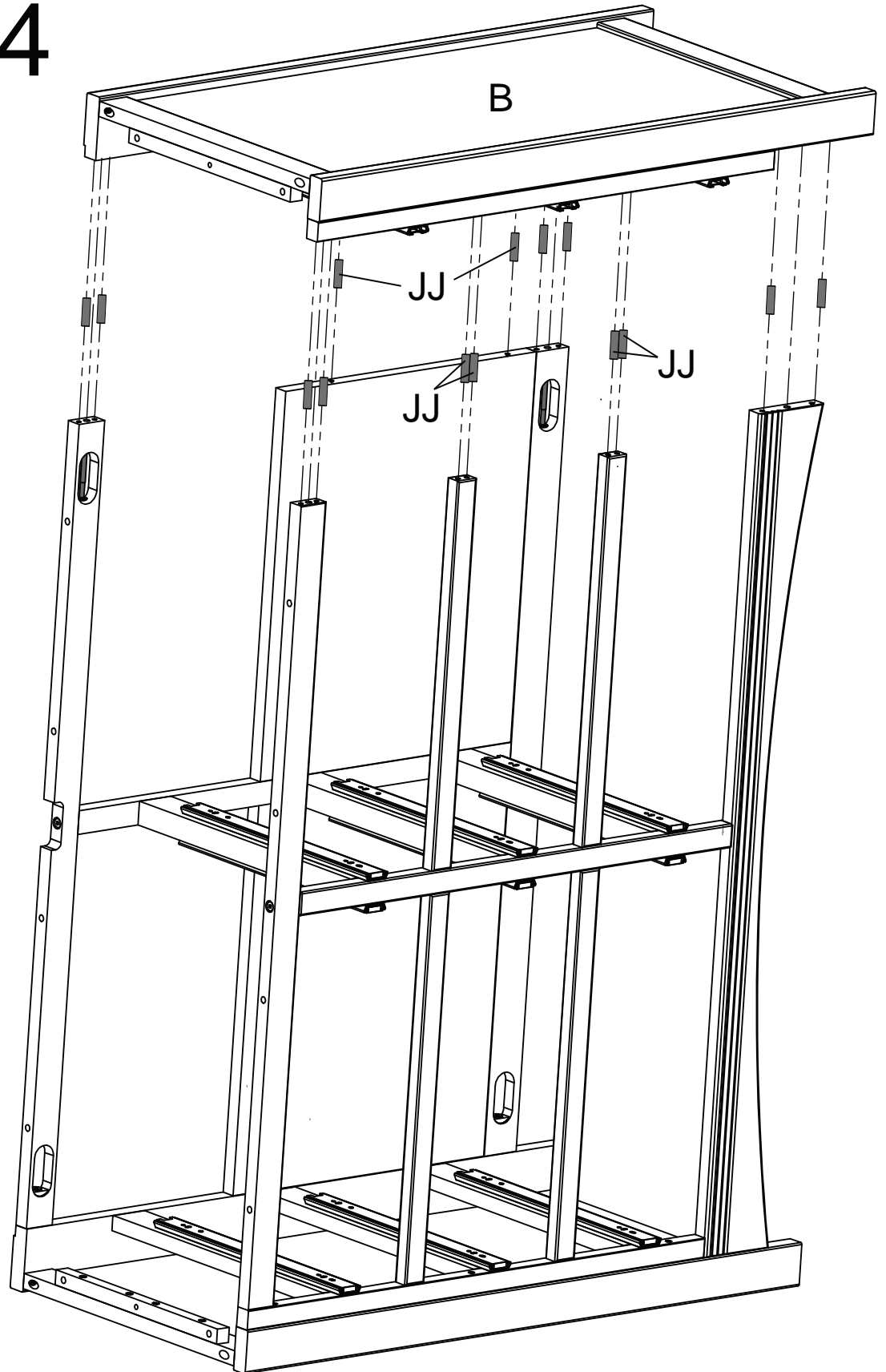



Step 7  
Étape 7  
Paso 7

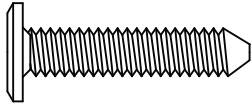
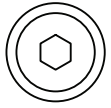

AA. 30mm Bolt x4  
Boulon 30mm  
Perno 30mm

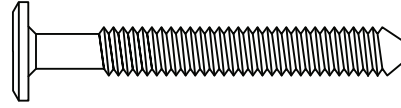
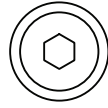

BB. 50mm Bolt x8  
Boulon 50mm  
Perno 50mm

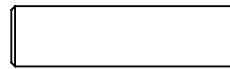

JJ.  $\Phi$ 8x30mm Dowel x2  
Cheville  $\Phi$ 8x30mm  
Pasador  $\Phi$ 8x30mm



M4 Allen Wrench  
Clé Allen M4  
Llave Allen M4

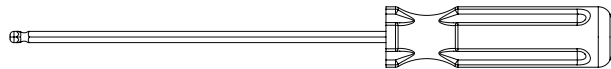

M4 Ballend Screwdriver  
tournevis M4 à tête sphérique  
destornillador M4 con cabeza de bola

Attach the Top Panel (Part G) to the assembly from Step 6 using (2)  $\Phi$ 8x30mm Dowels (Part JJ), (4) 30mm Bolts (Part AA) and (8) 50mm Bolts (Part BB). Tighten the Bolts with the M4 Ballend Screwdriver and M4 Allen wrench.

Fixer le Panneau Avant (Pièce G) au montage assemblé à l'étape 6 à l'aide de (2) Chevilles  $\Phi$ 8x30mm (Pièce JJ), (4) Boulons 30 mm (Pièce AA) et (8) Boulons 50 mm (Pièce BB) à l'aide de du tournevis M4 à tête sphérique et la clé Allen M4.

Fije el Panel Superior (Pieza G) al ensamblaje del Paso 6 utilizando (2) Pasadores  $\Phi$  8x30mm (Pieza JJ), (4) Pernos 30 mm (Pieza AA) y (8) Pernos 50 mm (Pieza BB) utilizando el destornillador M4 con cabeza de bola y la llave Allen M4.

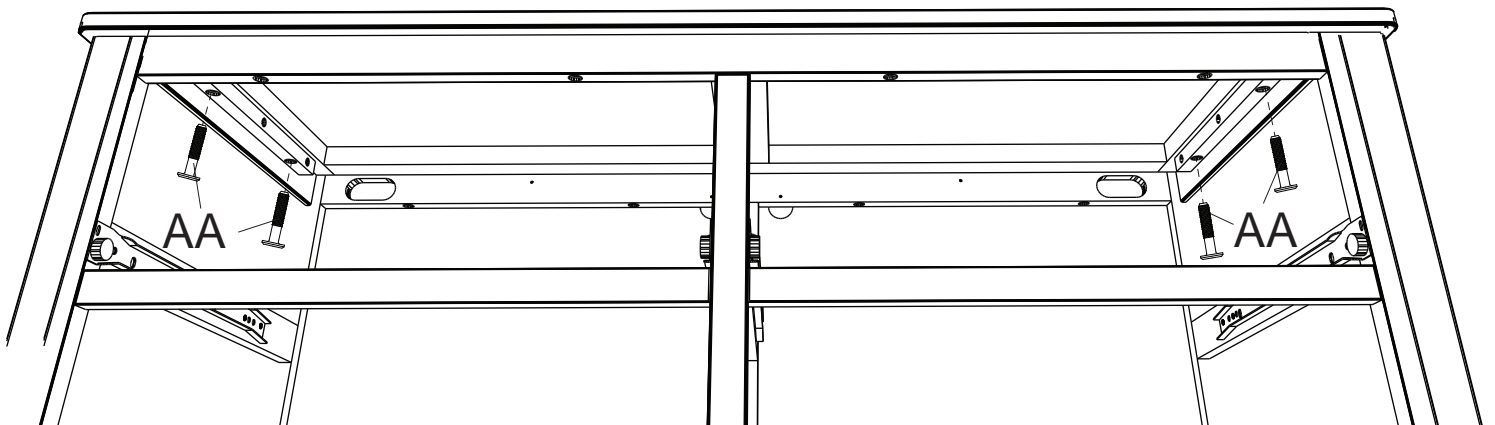
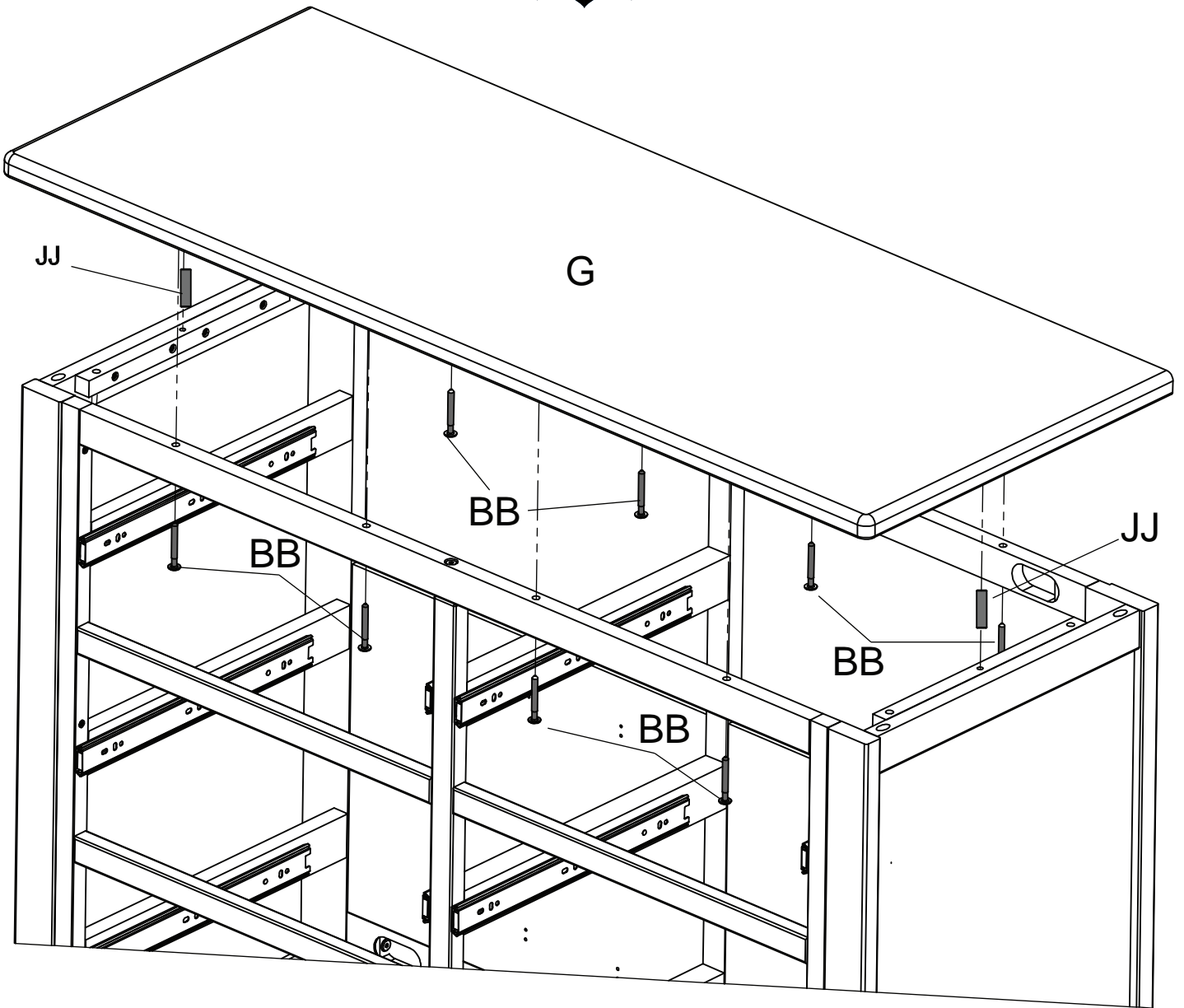



Step 8  
Étape 8  
Paso 8

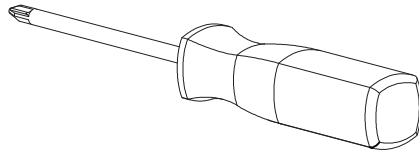

Phillips Screwdriver – Not included  
Tournevis Phillips - non inclus  
Destornillador Phillips – no incluido

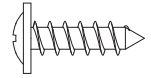

FF. Back Panel Screw x22  
Vis pour Panneau Arrière  
Tornillo de Panel Trasero

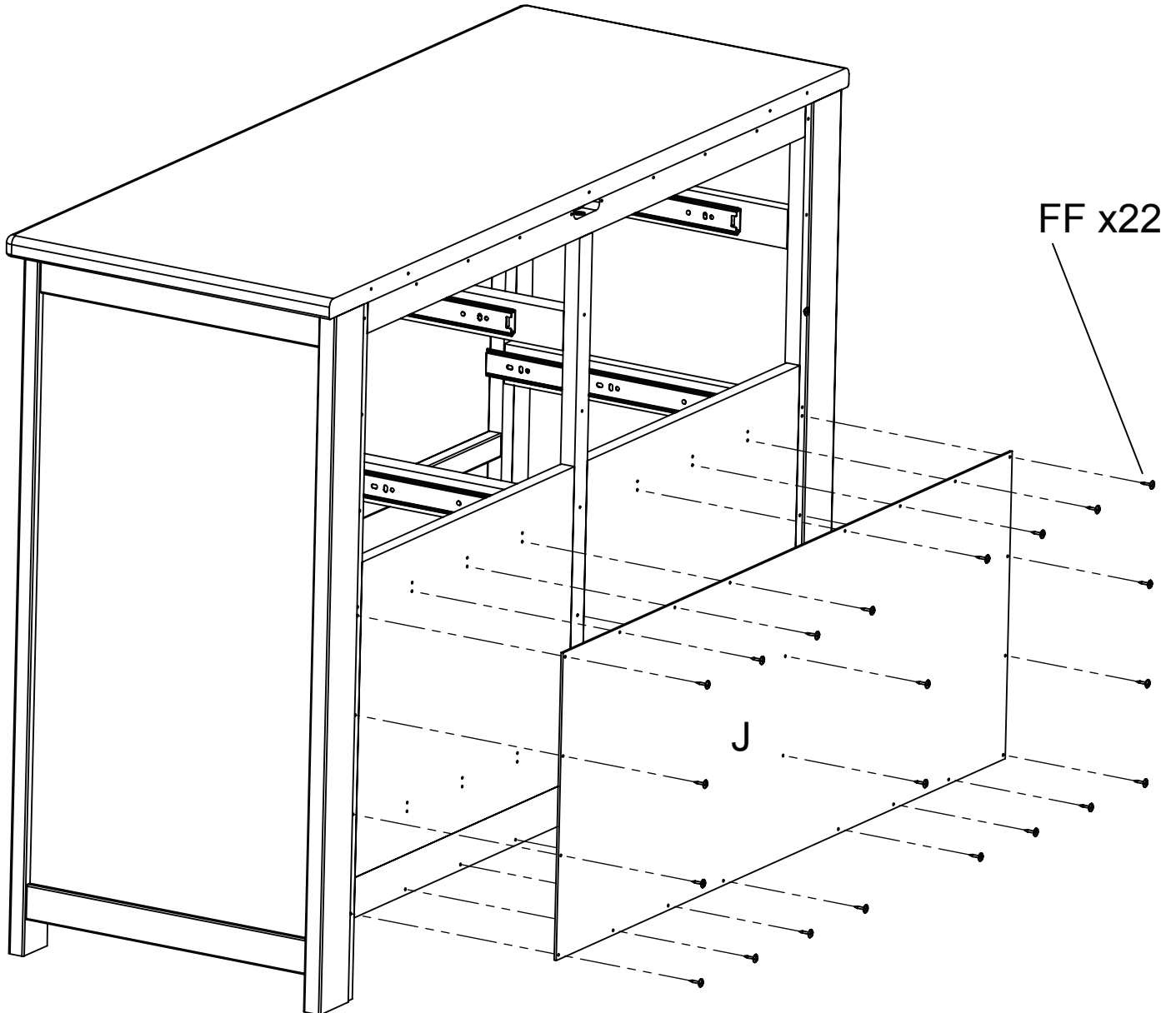

Attach Back Panel-Lower (Part J) using (22) 15mm Screws (Part FF), tighten with a Phillips screwdriver.

Fixez le Panneau arrière - Inférieur (Pièce J) à l'aide de (22) vis de 15 mm (Pièce FF), serrez à l'aide d'un tournevis cruciforme.

Una el Panel Inferior Trasero (Pieza J) utilizando (22) tornillos de 15 mm (Pieza FF), apriete utilizando un destornillador Philips.





Step 9  
Étape 9  
Paso 9

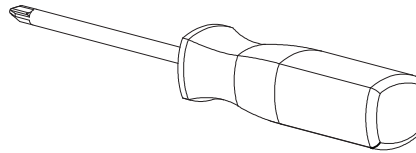

Phillips Screwdriver – Not included  
Tournevis Phillips - non inclus  
Destornillidor Phillips – no incluido

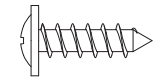

FF. Back Panel Screw x24  
Vis pour Panneau Arrière  
Tornillo de Panel Trasero

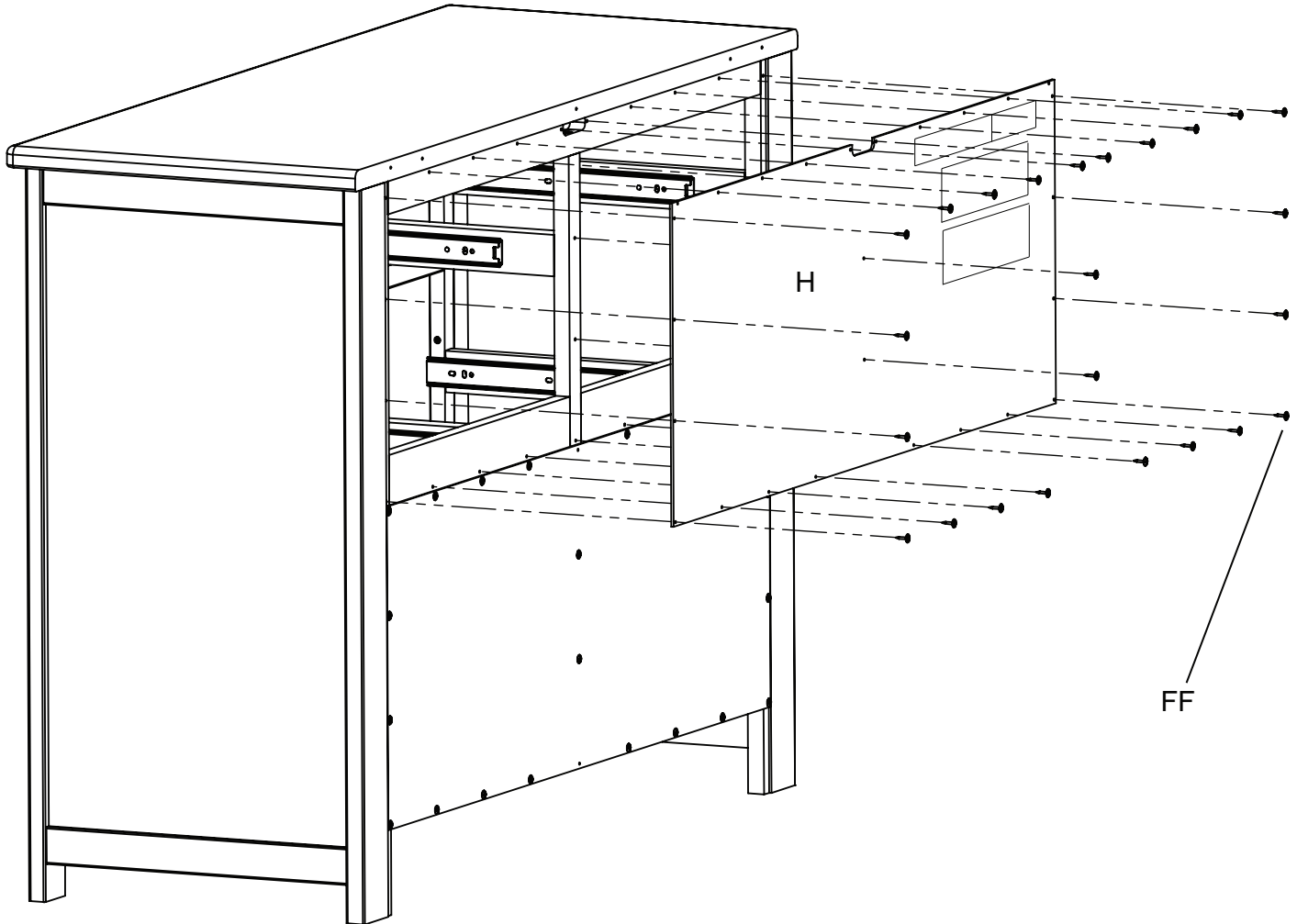

Attach Back Panel-Upper (Part H) using (24) 15mm Screws (Part FF), tighten with a Phillips screwdriver.

Fixez le Panneau arrière - Supérieur (Pièce H) à l'aide de (24) vis de 15 mm (Pièce FF), serrez à l'aide d'un tournevis cruciforme.

Una el Panel Trasero Superior (Pieza H) utilizando (24) tornillos de 15 mm (Pieza FF), apriete utilizando un destornillador Philips.

Step 10  
Étape 10  
Paso 10

Tipover Restraint  
Dispositif de non-renversement  
Protección contra volcamiento

**▲WARNING**

Use of tip-over restraints may only reduce, but not eliminate, the risk of tip-over.

Do not attempt to screw into the wallboard only. You must screw into a wood wall stud or other wood structure such as securely attached baseboard. If your wall is not wood stud construction, see your local hardware store or home center for a wall anchor system that will hold a pull force of 50 LBS in your wall type. If you are unsure of how to locate the wood stud, or of what type of wall you have, contact a professional contractor.

**▲AVERTISSEMENT**

L'utilisation de dispositif anti-renversement peut uniquement réduire les risques de renversement, mais ne les élimine pas totalement.

Ne tentez pas de le visser dans le panneau de revêtement uniquement. Vous devez visser dans un poteau mural en bois ou toute autre structure en bois telle qu'une plinthe solidement fixée. Si votre mur n'est pas construit de montants de bois, voyez votre quincaillerie locale ou centre de rénovation pour une ancre de mur pouvant supporter 50 livres dans votre type de mur. Si vous êtes incertain par rapport à comment localiser le montant ou à quel type de mur vous avez, contactez un entrepreneur professionnel.

**▲ADVERTENCIA**

El uso de herramientas de contención de vuelcos tan solo puede reducir, pero no eliminar, el riesgo de vuelco.

No intente atornillar a paredes hechas únicamente de paneles. Debe atornillar en un pilar u otra estructura de madera similar, como un zócalo fijado de manera segura. Si su pared no tiene vigas de Madera, visite su ferretería o tienda del ramo más cercana para conseguir un sistema de anclaje que soporte una fuerza de tiraje de hasta 50 LBS (22,7 Kgs) para su tipo de muro. Si no está seguro sobre cómo encontrar la viga de madera o tiene dudas sobre el tipo de muro, contacte a un contratista profesional.

- 1) Choose BOTTOM or TOP attachment.
- 2) Locate the through holes in the back of the dresser.
- 3) Align the hole to be used with the wood wall stud (For Open Bottom Installation, use wood wall stud closest to center)
- 1) Choisissez une fixation SUPÉRIEURE ou INFÉRIEURE.
- 2) Repérez les trous percés au dos de la commode.
- 3) Alignez le trou à utiliser sur le poteau mural en bois (Pour une installation à fond ouvert, utilisez le poteau mural le plus près du milieu)
- 1) Seleccione el aditamento SUPERIOR o INFERIOR.
- 2) Ubique los orificios pasantes en la parte posterior del mueble.
- 3) Alinee el orificio que utilizará con el pilar de la pared (para una instalación con fondo abierto, utilice el pilar de madera más cercano al centro)

4) Make a pencil mark on the wall using the wood rail as a guide, pencil mark must be over wood wall stud. Then move the case away from the wall.

4) Faites une marque sur le mur à l'aide d'un crayon en vous servant du barre en bois comme guide, la marque au crayon doit être au-dessus du poteau mural en bois. Ensuite, déplacez la caisse afin de l'éloigner du mur.

4) Utilizando un lápiz, haga una marca en la pared utilizando el barra de madera como guía; la marca debe estar sobre el pilar de madera. Luego, aleje la carcasa de la pared.

- 5) Drill  $\varnothing 1/8$ " hole at Pencil Mark, in wood wall stud
- 5) Percez un trou de 1/8 po de diamètre à l'emplacement de la marque au crayon, dans le poteau mural en bois
- 5) Perfore un orificio de  $\varnothing 1/8$ " en la marca del lápiz, sobre el pilar de madera

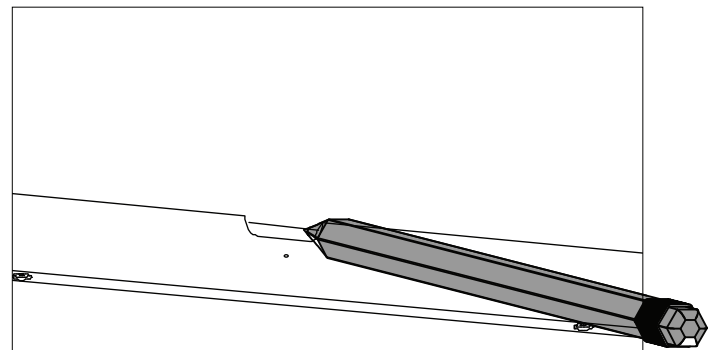
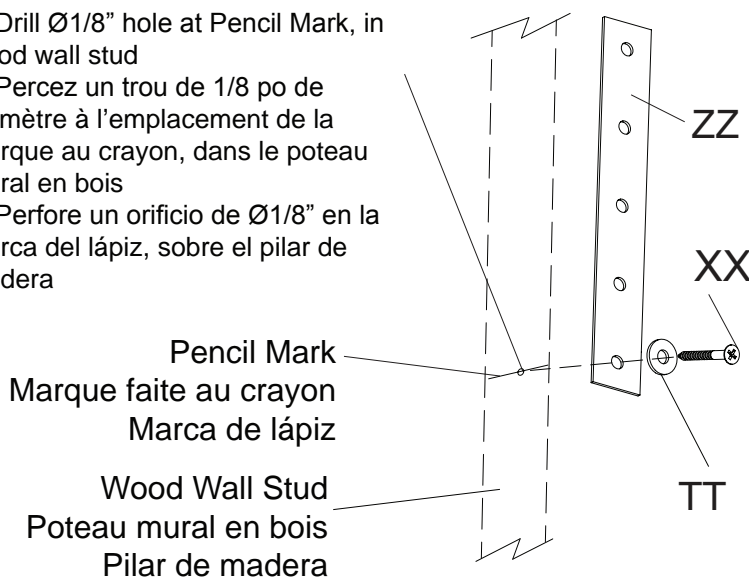

6) Attach the Tip-over restraint strap (ZZ) to the wall using (1) Long Screw (XX) and (1) washer (TT) as shown. The screw MUST be installed into a wood wall stud (See WARNINGS for additional information).

6) Fixez la sangle du dispositif de non-renversement (ZZ) au mur à l'aide de (1) vis longue (XX) et de (1) rondelle (TT) tel qu'illustré. La vis DOIT être serrée dans un poteau mural en bois (Pour de plus amples informations, veuillez vous référer aux AVERTISSEMENTS).

6) Fije la correa de retención contra volcamiento (ZZ) a la pared utilizando (1) tornillo largo (XX) y (1) arandela (TT), como se indica. El tornillo DEBE instalarse en un pilar de madera (para obtener más información consulte las ADVERTENCIAS).



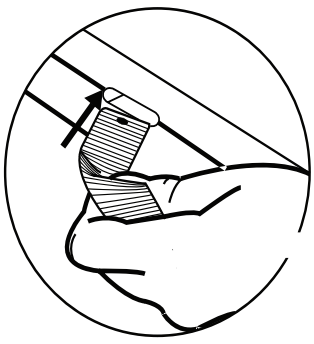

NOTE: Be sure to attach any accessory items to case before completing this step.  
 7) Feed the Tipover Restraint through the hole as you place the dresser in its final position.  
 REMARQUE : Veuillez à fixer tous accessoires sur la caisse avant de l'exécution de cette étape.  
 7) Faites entrer le dispositif de non-renversement à travers le trou lorsque vous placez la commode dans sa position finale.  
 NOTA: Asegúrese de fijar todos los accesorios a la carcasa antes de completar este paso.  
 7) Pase el elemento de retención a través del orificio, a medida que posiciona el mueble en su posición final.

8) Pull the Tip-over restraint through the hole and fasten it securely to the case using (1) 15mm screw (YY) and (1) washer (TT).  
 8) Tirez le dispositif de non-renversement à travers le trou, puis fixez-le solidement sur la caisse à l'aide de (1) vis de 15 mm (YY) et de (1) rondelle (TT).  
 8) Pase el elemento de retención a través del orificio y fíjelo con seguridad a la carcasa utilizando (1) tornillo de 15 mm (YY) y (1) arandela (TT).

Attach to Top  
 Fixez-le à la partie supérieure  
 Fijar a la parte superior

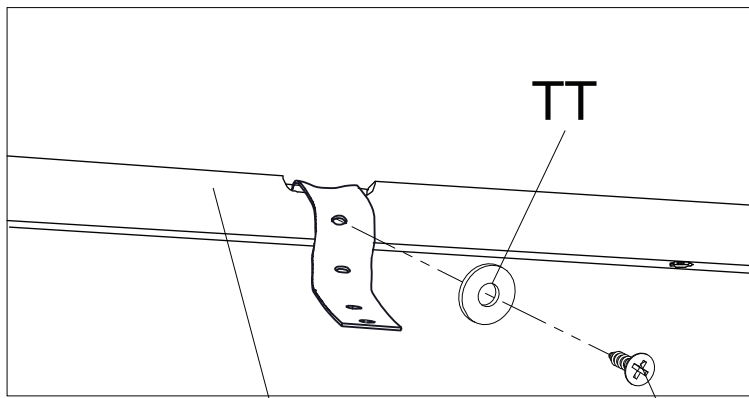

Top Back Rail  
 Barre Arrière Supérieur  
 Barra Trasero Superior

Attach to Bottom  
 Fixez-le à la partir inférieure  
 Fijar al fondo

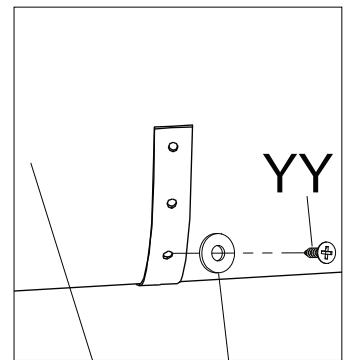

Bottom Back Rail  
 Barre Arrière Inférieur  
 BarraTraseroInferior

9) Pull case AWAY from wall until Restraint is SNUG.  
 9) Tirez la caisse afin de L'ÉLOIGNER du mur jusqu'à ce que le dispositif de non-renversement soit BIEN AJUSTÉ  
 9) Jale la carcasa ALEJÁNDOLA de la pared hasta que la retención esté TENSA.

10) Ensure restraint is not loose.  
 10) Assurez-vous que le dispositif de non-renversement n'est pas desserré.  
 10) Asegúrese de que la retención no esté suelta.

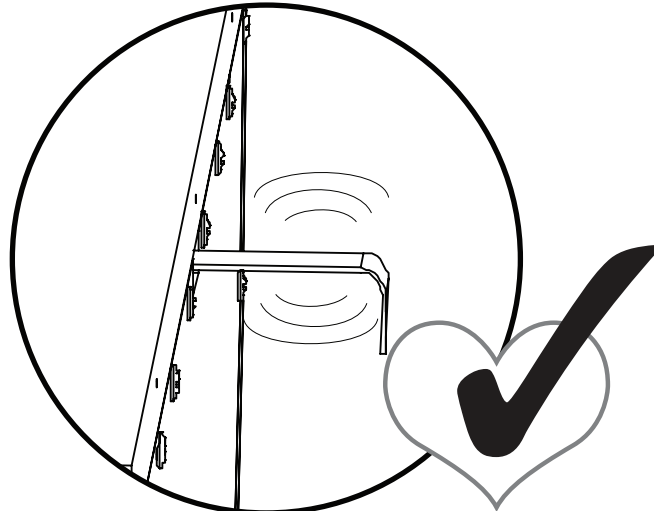
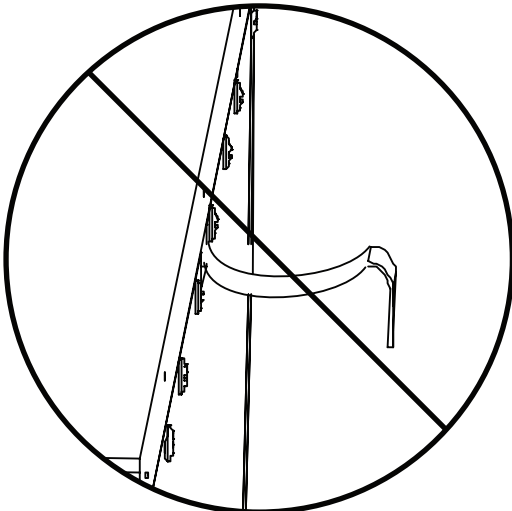



Step 11  
Étape 11  
Paso 11

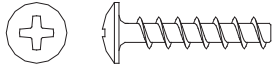

EE. 20mm Screw x24  
Vis 20mm  
Tornillo 20mm

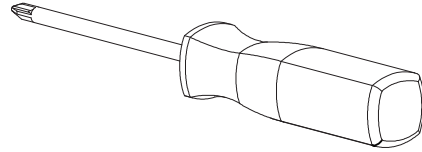

Phillips Screwdriver – Not included  
Tournevis Phillips - non inclus  
Destornillidor Phillips – no incluido

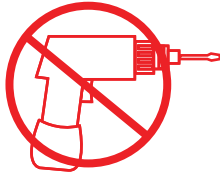

**CAUTION:** Do Not use a power screwdriver they can cause screws to break or strip.  
**ATTENTION:** Ne Pas utiliser un tournevis électrique car les vis peuvent casser ou perdre leurs filets.  
**ATENCIÓN:** No use un destornillador eléctrico ya que puede causar que los tornillos se rompan o rueden.

Slide Drawer Bottom (Part N) into the grooves. Attach the Drawer Sides (Part L) to the Drawer Front (Part K ) with (4) 20mm Screws (Part EE). Note: Grooves in Bottom must align. Tighten With Phillips Screwdriver. Repeat this step until 6 drawers are complete.

Glisser le fond du tiroir (Pièce N) dans les rainures. Fixer les côtés des tiroirs (Pièces L) à l'avant du tiroir (Pièce K ) à l'aide de (4) vis 20mm (Pièce EE). Remarque: Les rainures inférieures doivent être alignées. Serrer avec un tournevis Phillips. Répéter cette étape jusqu'à ce que les 6 tiroirs soient montés.

Deslice la Fondo de la gaveta (Pieza N) hacia las ranuras. Fije los lados de la gaveta (Pieza L) a la parte frontal de la gaveta (Pieza K ) utilizando (4) tornillos 20mm (Pieza EE). Nota: Las ranuras al inferior deben alinearse. Apriete utilizando un destornillador Phillips. Repitaestepaso hasta haber completadolos 6 gavetas .



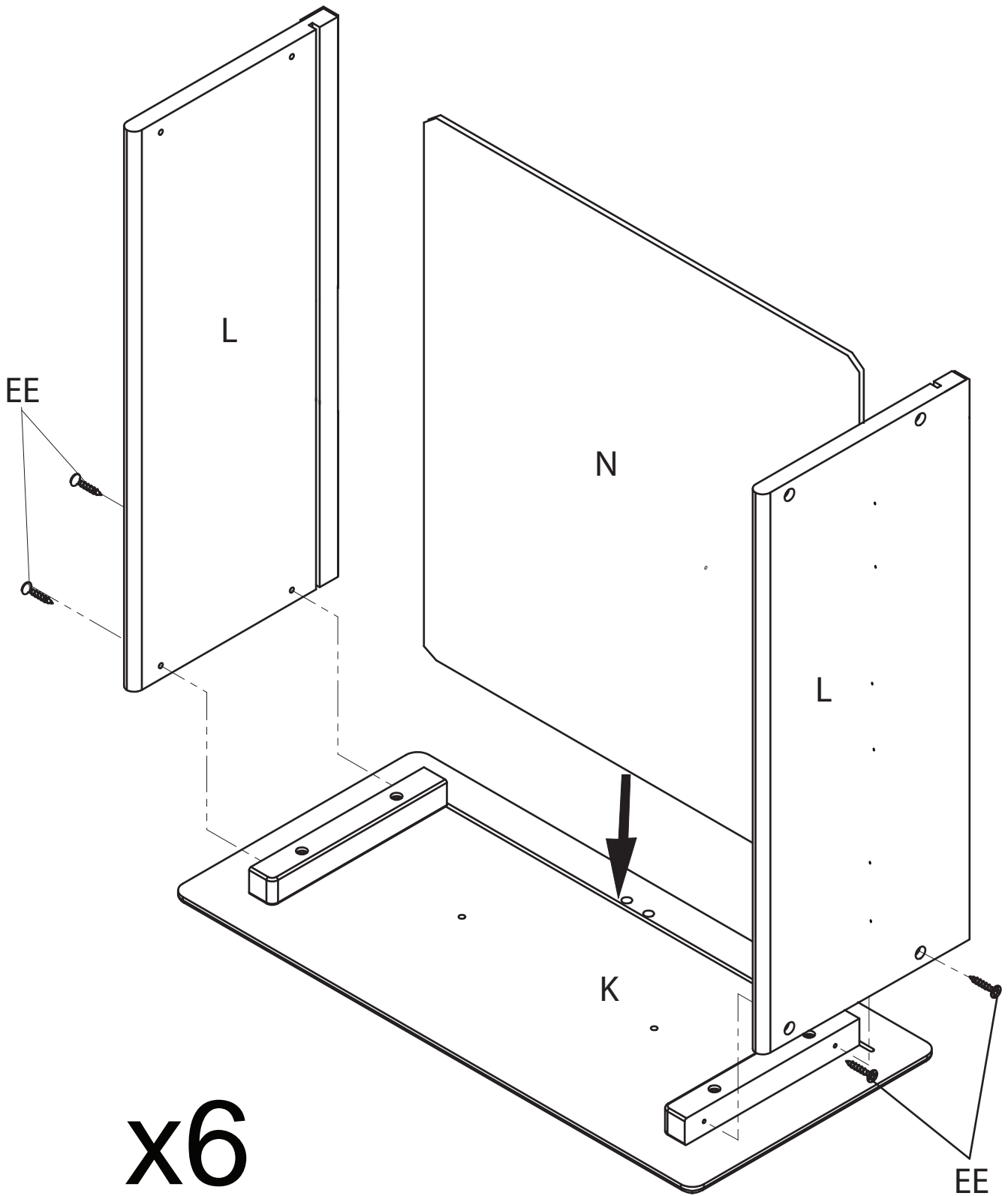

x6



Step 12  
Étape 12  
Paso 12

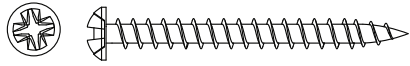

GG. 40mm SCREW x30  
Vis 40mm  
Tornillo 40mm

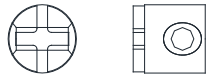

LL. Plastic Barrel Nut x30  
Écrou à portée cylindrique  
en plastique  
Tuercacilíndricaplástica

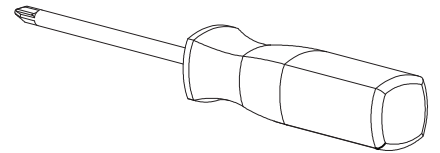

Phillips Screwdriver – Not included  
Tournevis Phillips - non inclus  
Destornillidor Phillips – no incluido

**CAUTION:** Do Not use a power screwdriver they can cause screws to break or strip.  
**ATTENTION:** Ne Pas utiliser un tournevis électrique car les vis peuvent casser ou perdre leurs filets.  
**ATENCIÓN:** No use un destornillador eléctrico ya que puede causar que los tornillos se rompan o rueden.

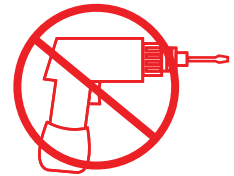

Install the Drawer Support (Part P) and Drawer Back (Part M), using (5) 40mm Screws (Part GG) and (5) Plastic Barrel Nuts (Part LL). Note: Grooves In Bottom Must Align. Tighten the screws with a Phillips Screwdriver. Repeat this step until 6 drawers are complete.

Installer le support du tiroir (Pièce P) et l'arrière du tiroir (Pièce M), à l'aide de (5) vis 40mm (Pièce GG) et de (5) Écrous à portée cylindriques en plastique (Pièce LL). Remarque: Les rainures inférieures doivent être alignées. Serrer avec un tournevis Phillips. Répéter cette étape jusqu'à ce que les 6 tiroirs soient montés.

Instale el soporte de gaveta (Pieza P) y Trasera de la gaveta (Pieza M) utilizando (5) tornillos de 40 mm (Pieza GG) y (5) tuercas cilíndricas plásticas (Pieza LL). Nota: Las ranuras al inferior deben alinearse. Apriete utilizando un destornillador Phillips. Repita este paso hasta haber completado las 6 gavetas.

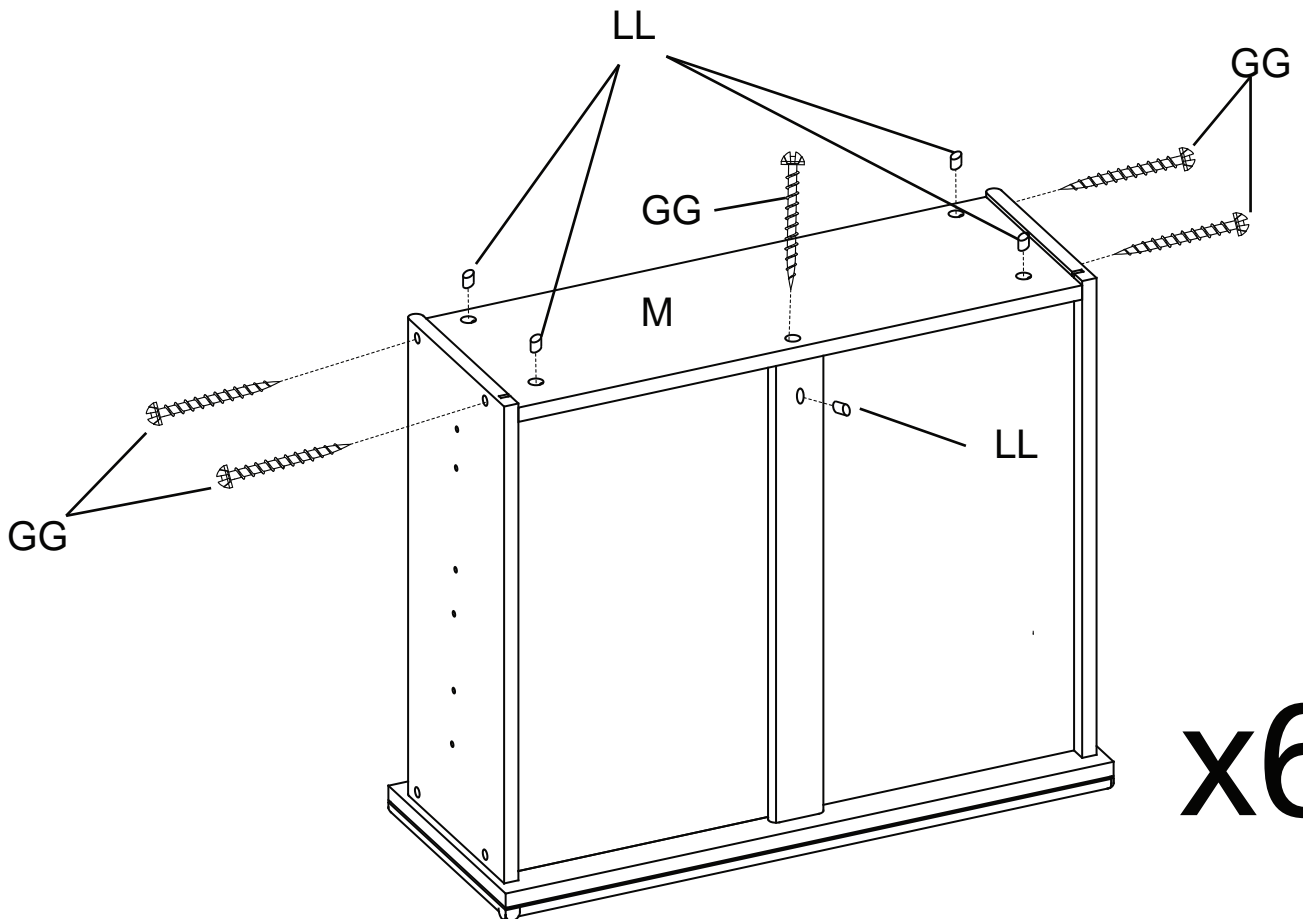
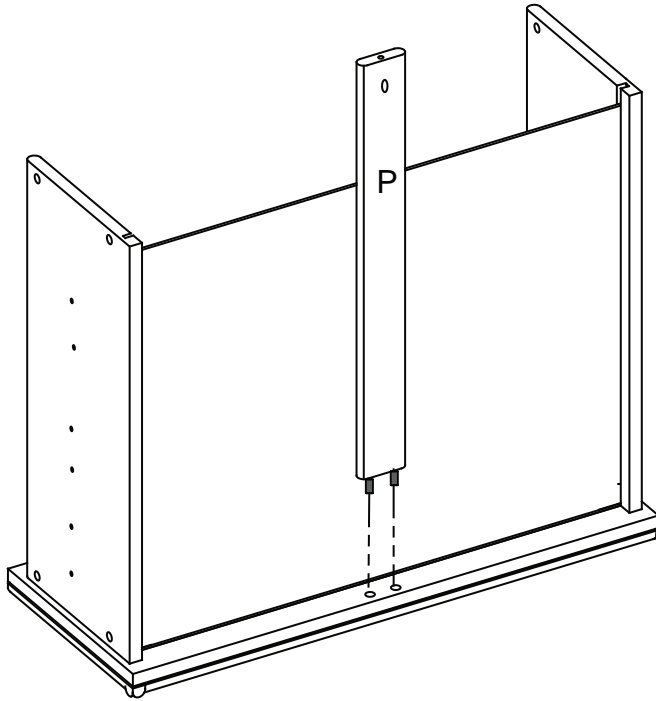



Step 13  
Étape 13  
Paso 13

CAUTION: Do Not use a power screwdriver they can cause screws to break or strip.  
ATTENTION: Ne Pas utiliser un tournevis électrique car les vis peuvent casser ou perdre leurs filets.  
ATENCIÓN: No use un destornillador eléctrico ya que puede causar que los tornillos se rompan o rueden.

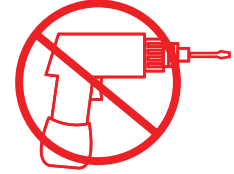

PP. Knob / Bouton / Perilla x6



PP2. Knob Screw  
Vis de Bouton  
Tornillo para Perilla

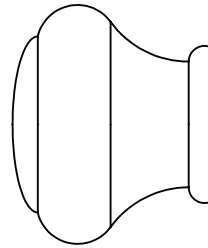

PP1. Knob  
Bouton  
Perilla

Attach (1) Knob (Part PP1) to Drawer Assembly using (1) Knob Screw (Part PP2). Repeat this step until 6 drawers are complete.

Fixer le (1) bouton (Pièce PP1) au montage assemblé du tiroir à l'aide d'(1) vis de Bouton (Pièce PP2). Répéter cette étape jusqu'à ce que les 6 tiroirs soient montés.

Fije la(1) perilla (Pieza PP1) al ensamblaje de la gaveta utilizando (1) tornillo para Perilla (Pieza PP2). Repita este paso hasta haber completado las 6 gavetas.

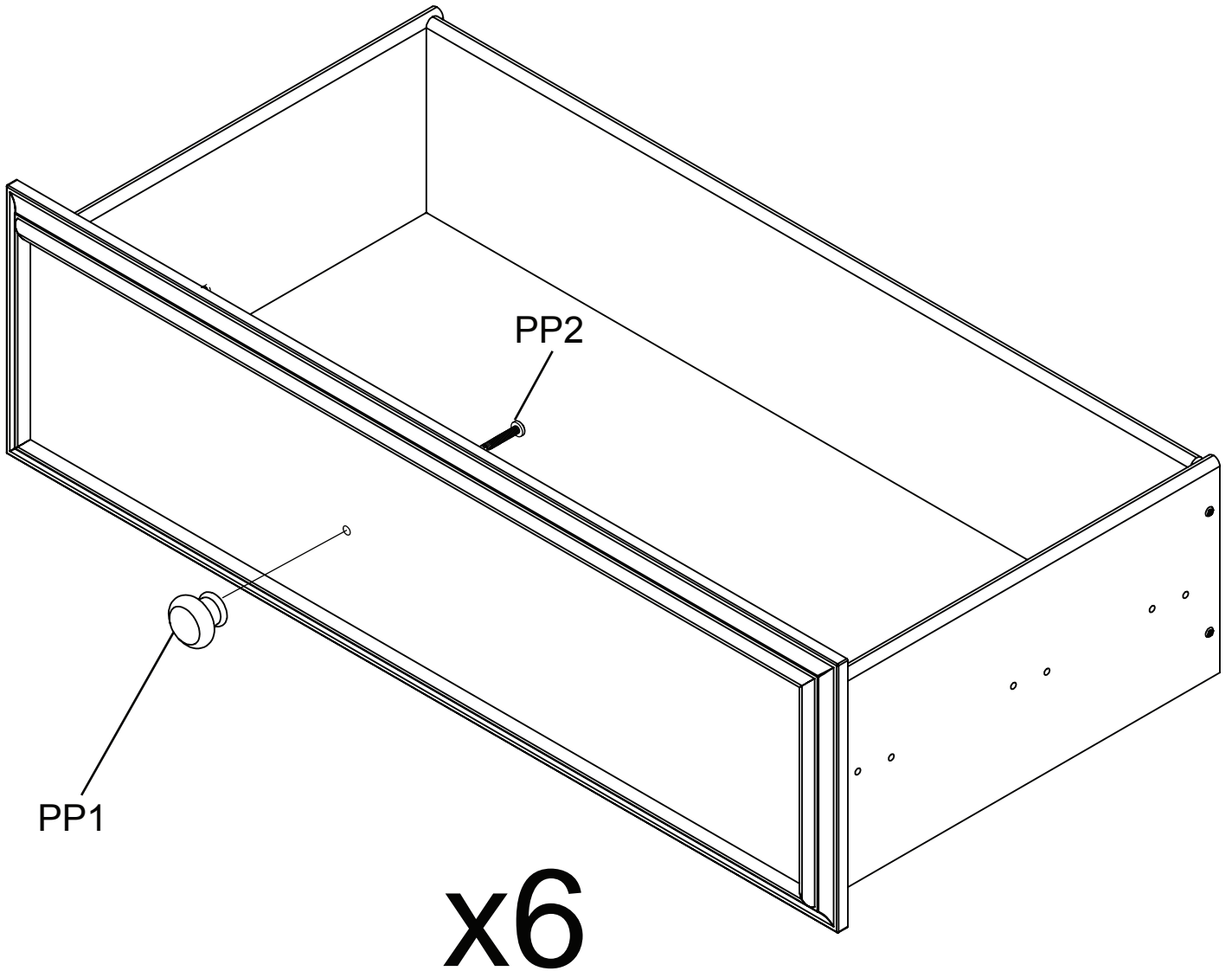



Step 14  
Étape 14  
Paso 14

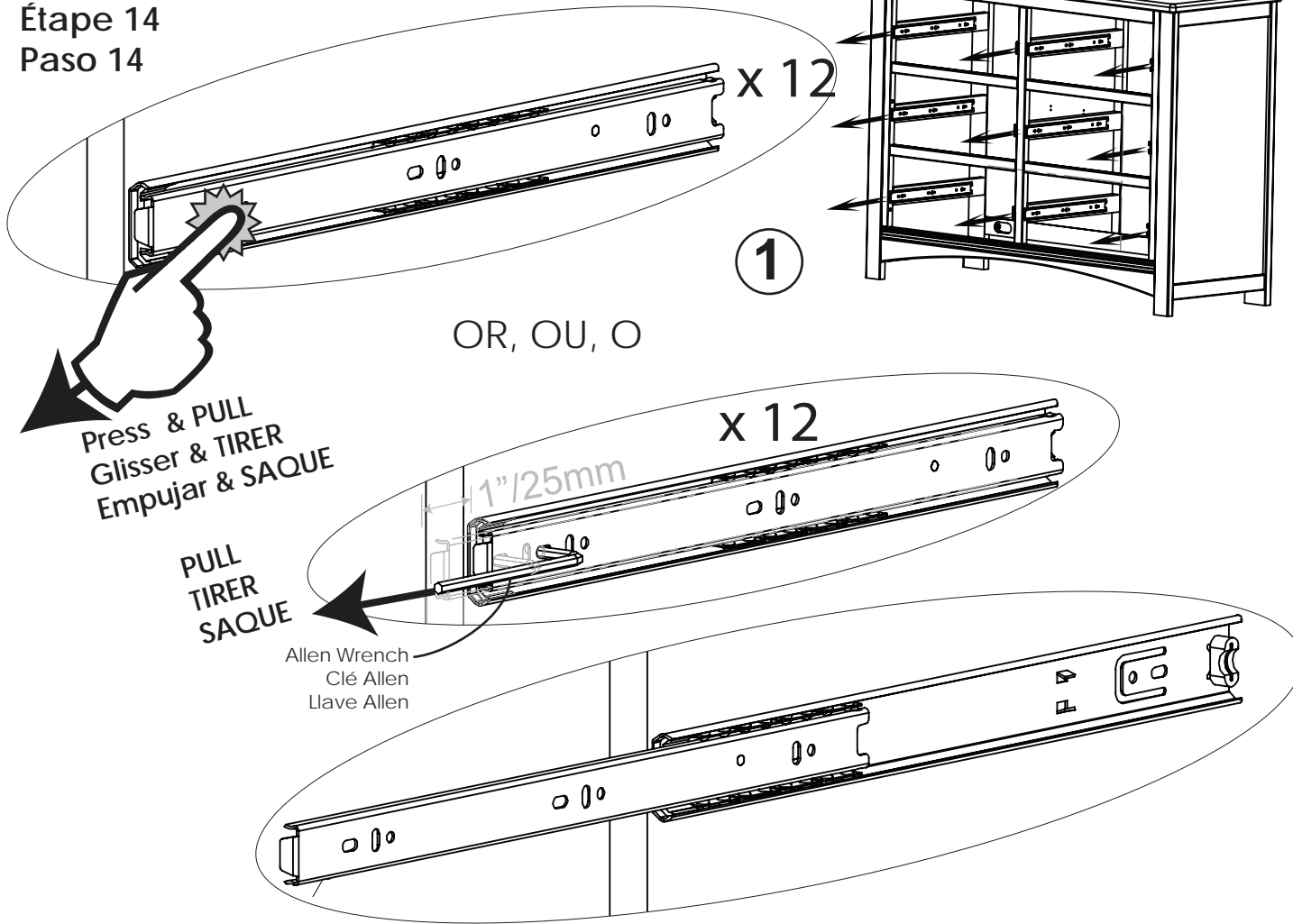

Left/Gauche/Izquierdo

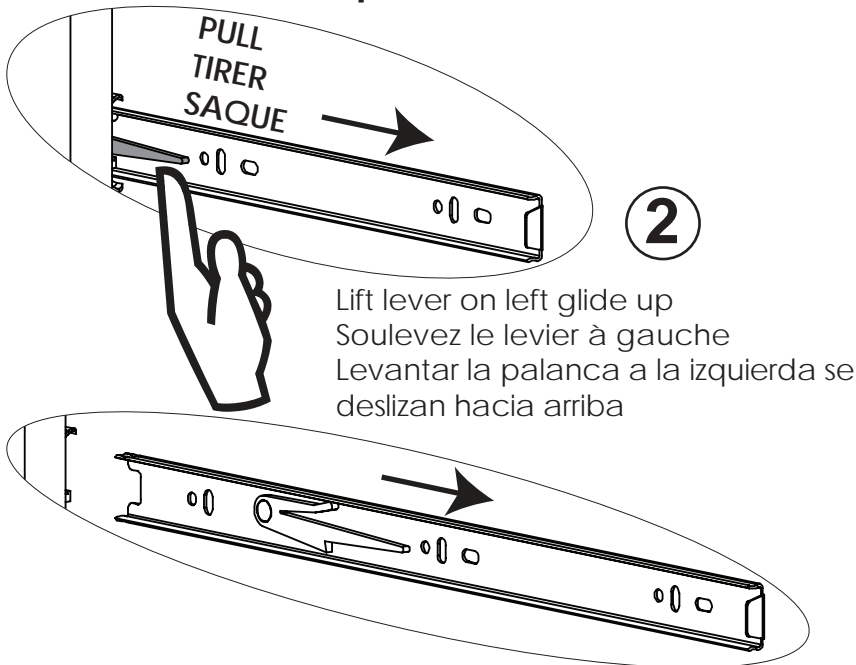

Right/Droite/Derecho

Press lever on right glide down  
Glisser sur le levier sur la droite  
glisser vers le bas  
Empujar la palanca a la derecha se desliza por

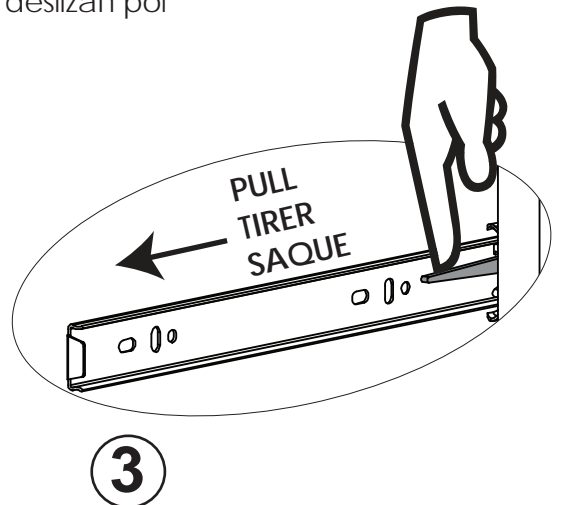





The silver portion of the glide must be pulled to the front of the glide when assembling the drawer into the case.

La partie argentée du glissement doit être tirée vers l'avant de la glisse lors du montage du tiroir dans le boîtier.

La parte plateada de la guía de la gaveta debe estar al frente de la guía cuando se está armando la cómoda.

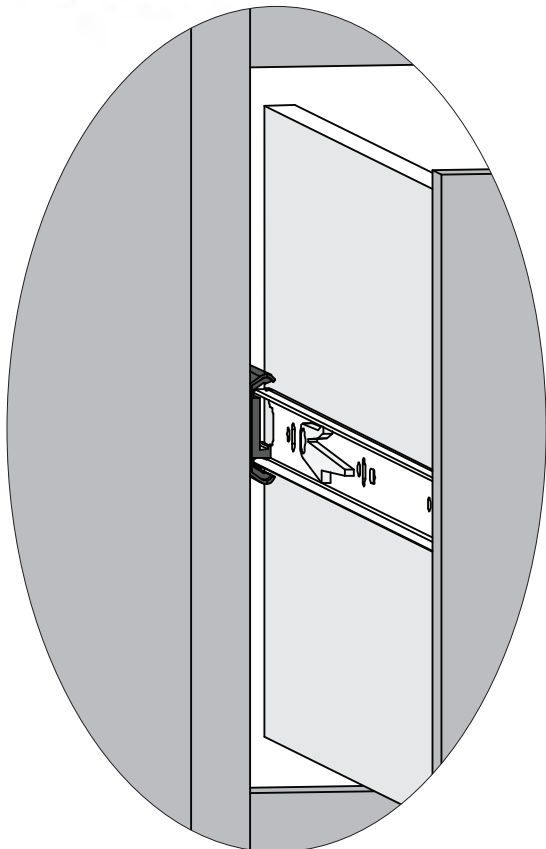
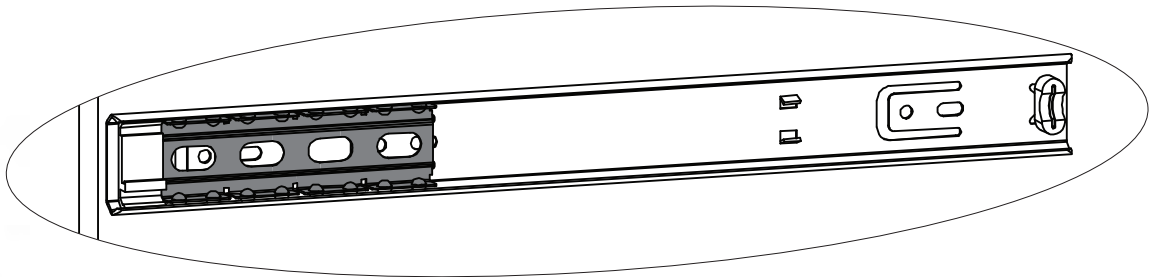
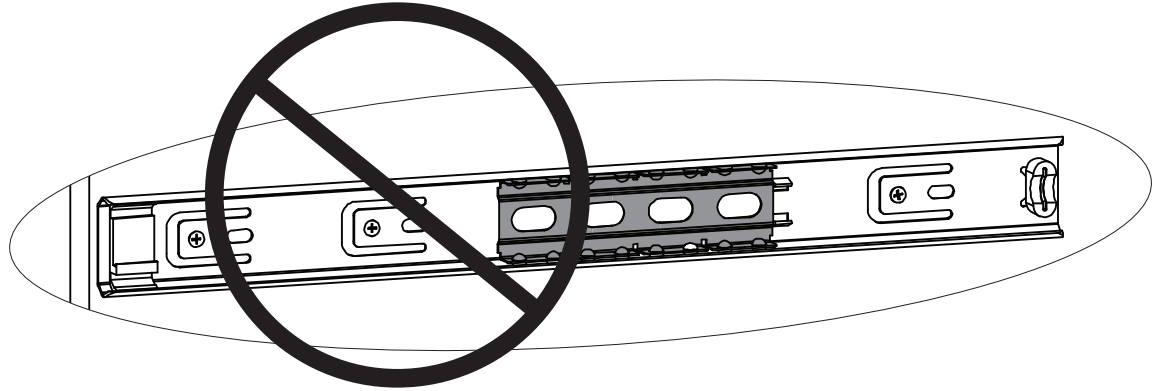

To insert drawer align male runner on drawer to female runner on case and push all the way in.

Pour insérer tiroir aligner runner homme sur le tiroir pour runner femme sur l'affaire et poussez jusqu'à ce qu'il repose.

Para insertar la gaveta alinear runner mujer en la gaveta para de hombre runner case y empuje hasta el fondo.



**Step 15**  
**Étape 15**  
**Paso 15**

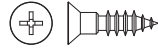

KK.12mm Screw x36  
Vis 12mm  
Tornillo 12mm

Attach (2) Drawer Guide outer pieces to each assembled drawer. There are pre-drilled holes in each drawer side.

- i) Place the end of the Drawer Guide with the tab against the Drawer front, then align the holes in the Guide to the holes in the Side, tab should remain very close to the Drawer Front.
- ii) Attach the Drawer Guide with (3) 12mm screws (Part KK). Install the screws from the back to the front (1st,2nd,3rd in the illustration). Tighten with a Phillips Screwdriver.
- iii) repeat with the other Drawer Side.
- iv) Repeat until all (6) Drawers are complete.

Fixer (2) parties extérieures de glissière de tiroir sur chaque tiroir monté. Des trous prépercés se trouvent sur le côté de chaque tiroir.

- i) Placer l'extrémité de la glissière de tiroir avec la patte contre l'avant du tiroir, puis aligner les trous de la glissière aux trous sur le côté. La patte doit rester très proche de l'avant du tiroir.
- ii) Fixez la glissière du tiroir à l'aide de (3) vis de 12 mm (Pièce KK) Montez les vis de l'arrière vers l'avant (1st,2nd,3rd sur l'illustration). Serrez à l'aide d'un tournevis cruciforme.
- iii) répéter cette étape avec le côté de l'autre tiroir.
- iv) Répéter jusqu'à ce que les (6) tiroirs soient montés.

Fije (2) piezas externas de guía de gaveta en cada gaveta ensamblada. Hay agujeros pre taladrados en cada costado de la gaveta.

- i) Coloque el extremo de la guía de gaveta, con la lengüeta contra la parte frontal de la gaveta, luego alinee la guía con los agujeros del costado; la lengüeta debe quedar muy cerca de la parte frontal de la gaveta.
- ii) Fije la guía de gaveta con (3) tornillos de 12 mm (Pieza KK). Instale los tornillos desde la parte posterior hacia el frente (1st,2nd,3rd en la ilustración). Apriete con un destornillador Philips.
- iii) Repita con el otro costado de la gaveta.
- iv) Repita hasta completar las (6) gavetas



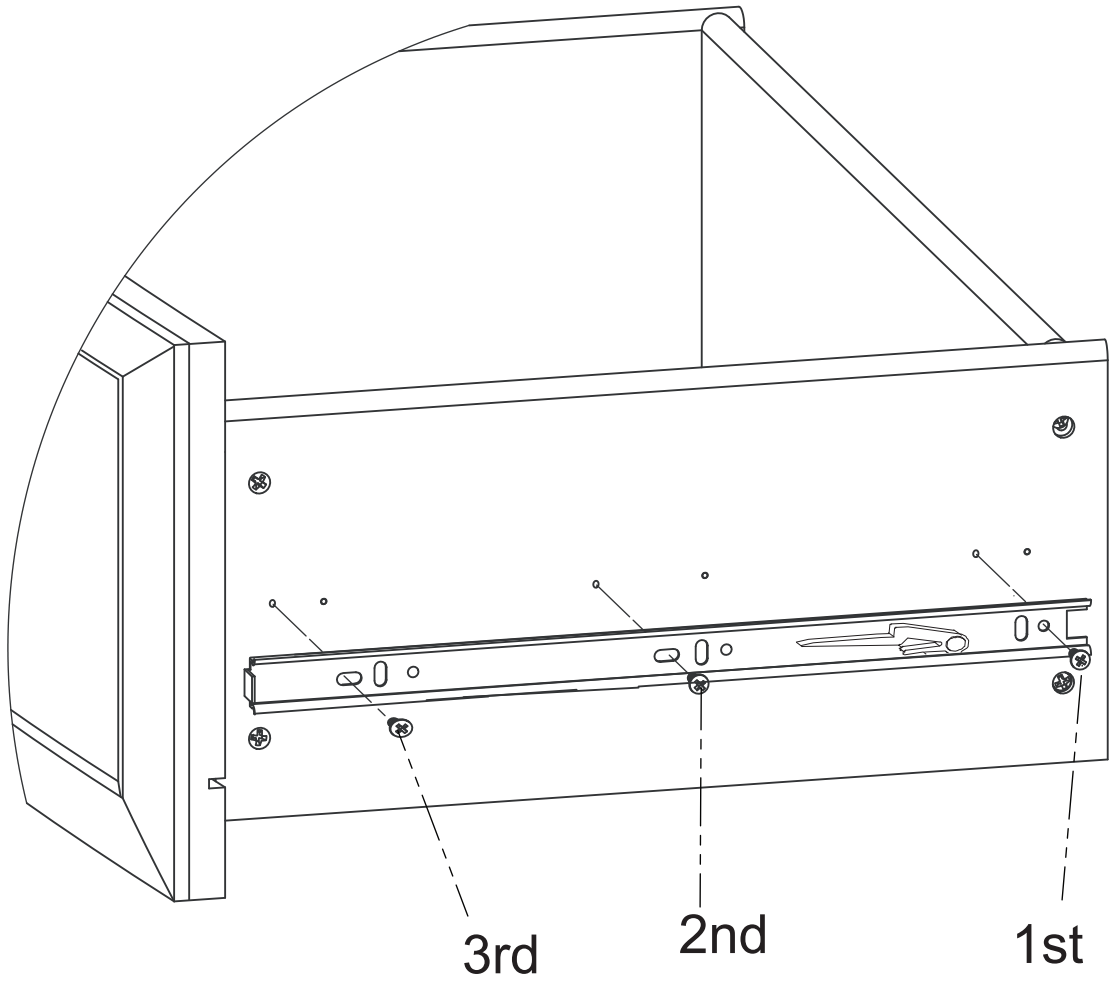

KK

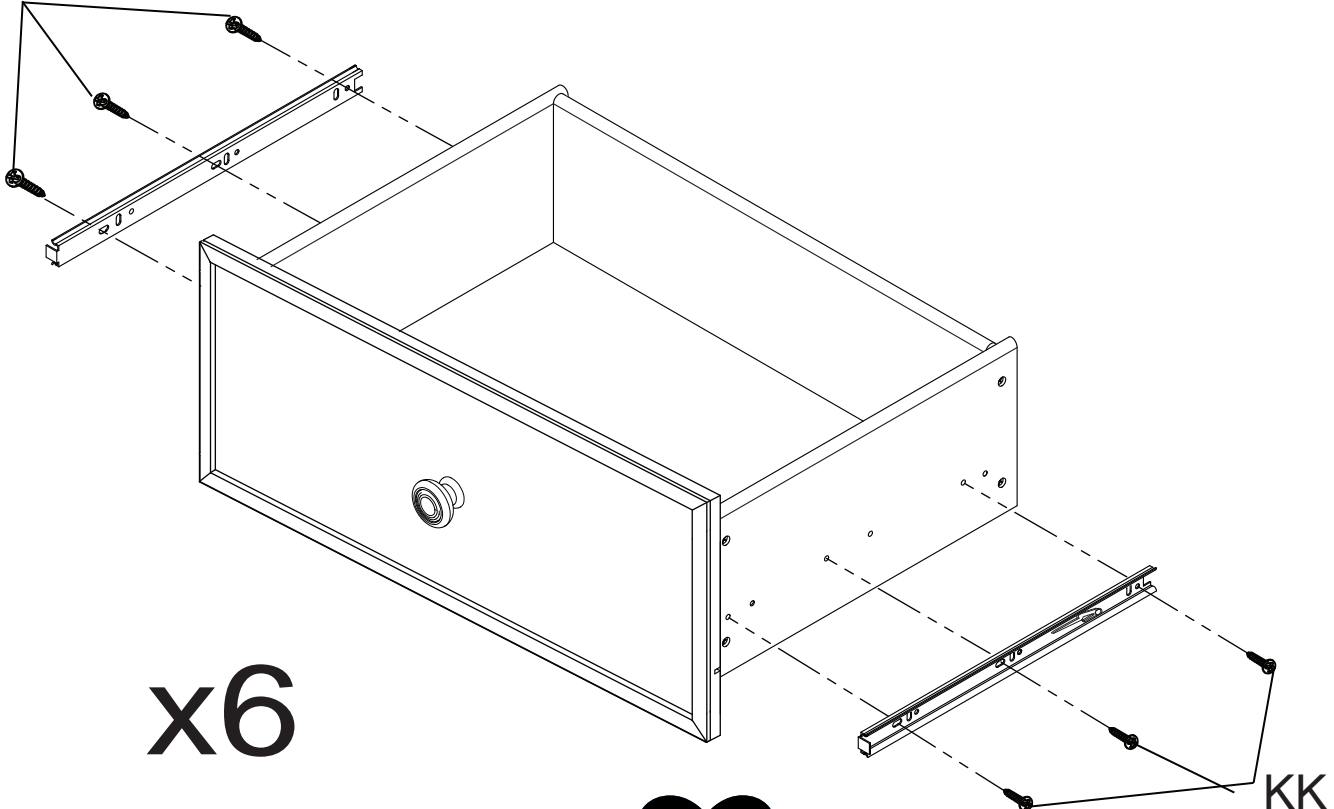

x6





Step 16  
Étape 16  
Paso 16

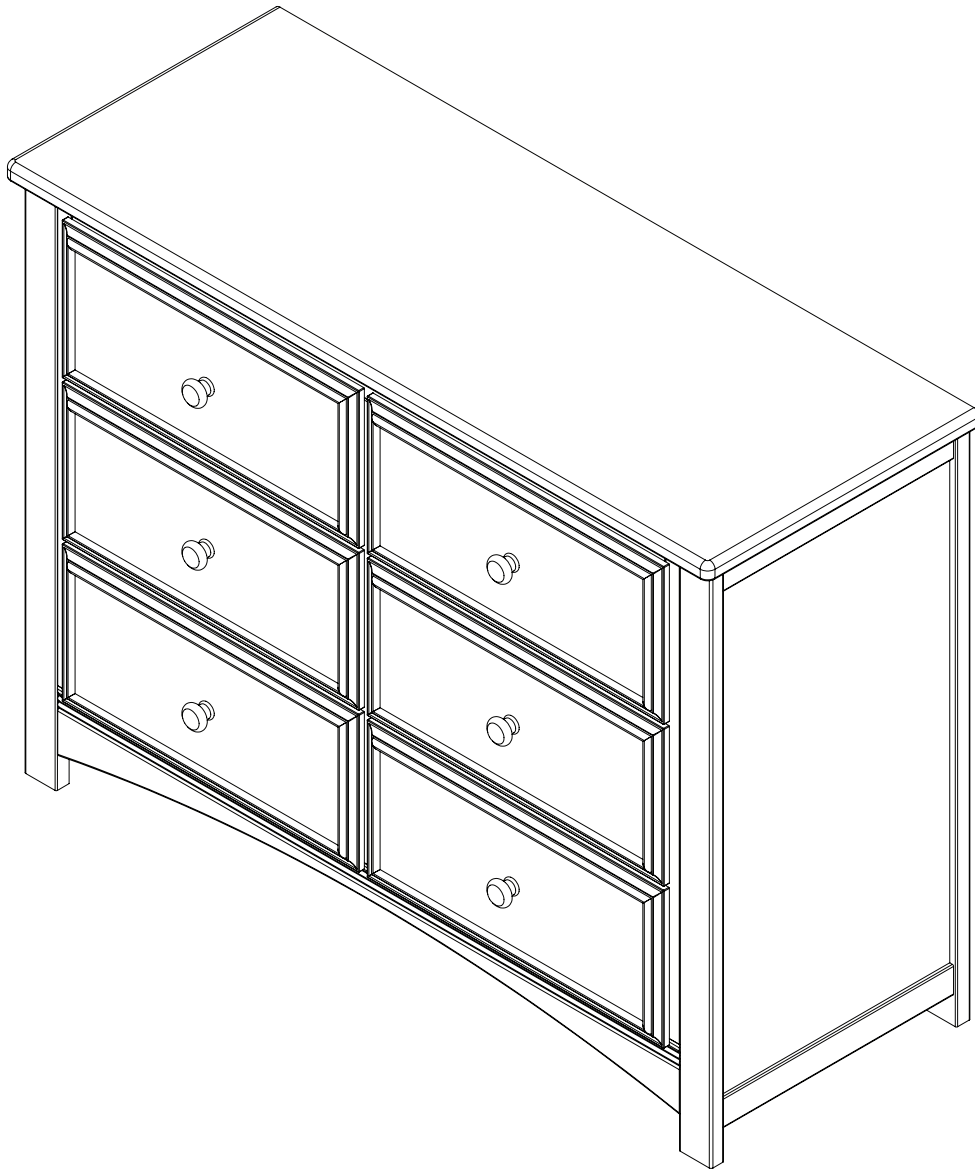

Install the drawers in the case body. Carefully align the Drawer Guides on each drawer with the Drawer Guides on the case. Push the drawer STRAIGHT in until it "clicks". Check that each side is fully secure. Open and close the drawer to ensure smooth operation. Changing the locations may improve fit or performance.

Installez les tiroirs dans le corps du boîtier. Prenez soin d'aligner les glissières de chaque tiroir avec les glissières destiroirs sur le boîtier. Poussez le tiroir HORIZONTALEMENT vers l'intérieur jusqu'à ce qu'il s'encastre. Vérifiez que chaque côté est bien fixé. Ouvrez et fermez le tiroir afin de vérifier qu'il fonctionne bien. Modifiez l'emplacement pour un meilleur ajustement ou de meilleures performances.

Instale las gavetas en el cuerpo del mueble. Alinee cuidadosamente las guías de gaveta en cada una de ellas con las guías del cuerpo del mueble. Presione la gaveta EN LÍNEA RECTA hasta que haga "clic". Revise que cada lado esté bien asegurado. Abra y cierre la gaveta para asegurarse de que funciona correctamente. Cambiar las ubicaciones podría mejorar el funcionamiento.





Consumer Experience Center

[www.DeltaChildren.com](http://www.DeltaChildren.com)

Delta Children's Products Corp

114 West 26th Street

New York, NY 10001

(646) 435-8727

[wcs@DeltaChildren.com](mailto:wcs@DeltaChildren.com)

**Limited Warranty:** This Delta product is warranted to be free from defects for a period of 90 days from the date of purchase under normal use. This warranty extends only to the original retail purchaser and is valid only when supplied with proof of purchase, or if received as a gift, when the registration is on file with Delta. This limited warranty **does not cover** the following:

- Products purchased as floor models or samples.
- Items purchased on an "as-is" basis, as a second hand product, or as a resale product.
- Items purchased at a Final sale, a "Going out of Business" sale or a Liquidation sale.

**Garantie Limitée:** Ce produit Delta est garanti libre de défauts pour une période de 90 jours à partir de son achat et dans des conditions normales d'utilisation. Cette garantie se donne uniquement à l'acheteur d'origine et elle est valable seulement sur présentation d'une preuve d'achat, ou si le produit a été reçu en tant que cadeau alors il doit avoir été enregistré chez Delta. Cette garantie limitée du fabricant **ne couvre pas** les cas suivants :

- Produits achetés comme modèles d'exposition ou échantillons.
- Articles achetés comme « en l'état », produits d'occasion ou revente des produits.
- Articles achetés en « vente finale », ventes dans « magasins en faillite » ou ventes par liquidation.

**Garantía Limitada:** Este producto Delta está garantizado de estar libre de defectos por un período de 90 días a partir de su adquisición, bajo uso normal. Esta garantía se otorga únicamente al comprador original y es válida solamente cuando se proporciona una prueba de compra, o si el producto fue recibido como un regalo, debe haber sido registrado con Delta. Esta garantía limitada del fabricante **no cubre** lo siguiente:

- Productos comprados como exhibiciones de la tienda o muestras.
- Artículos comprados como "tal como está", productos de segunda mano o reventa de los productos.
- Artículos comprados como "venta final", "ventas de tiendas que están quebrando" o ventas por liquidación.

To register your product for important safety alerts and updates to your product please visit **[www.deltachildren.com](http://www.deltachildren.com)**

Pour enregistrer votre produit pour avoir les alertes de sécurité et les mises à jour de votre produit veuillez visiter **[www.DeltaChildren.com](http://www.DeltaChildren.com)**

Para registrar su producto para alertas importantes de seguridad y estar al tanto sobre novedades de su producto por favor visite **[www.DeltaChildren.com](http://www.DeltaChildren.com)** y seleccione Product Registration.

To report a problem, please log on to **[www.deltachildren.com](http://www.deltachildren.com)** and click the Consumer Care Tab, or contact us by phone at (646) 435-8727

Pour signaler un problème, veuillez vous connecter à **[www.DeltaChildren.com](http://www.DeltaChildren.com)** et cliquez sur la touche Consumer Care, ou contactez nous par téléphone au (646) 435-8727

Para reportar cualquier problema, por favor entre a **[www.DeltaChildren.com](http://www.DeltaChildren.com)** y de clicen Servicio al cliente o contáctenos por teléfono al (646) 435-8727

**Date of Purchase:** \_\_\_\_\_ (you should also keep your receipt)

**Date d'Achat:** \_\_\_\_\_ (vous devriez aussi garder votre facture d'achat)

**Fecha de Compra:** \_\_\_\_\_ (debe además mantener su recibo)



# SAFETY LEADERS

Visit [Deltachildren.Com/Pages/Leaders-In-Safety](https://Deltachildren.Com/Pages/Leaders-In-Safety) for more information

## SAFE MATERIALS

Safe products start with safe materials. We test all of our products to create the safest and healthiest environment for your baby.



## PRODUCTS YOU CAN TRUST

We have 8 cutting edge safety labs around the world where we test our products above and beyond the industry standards. All of our dressers are engineered to meet or exceed ASTM Furniture Safety Standards.



## WE GO ABOVE & BEYOND

To protect your children, Delta Children dressers are tested to meet the requirements of the industry tip over test set forth by ASTM. For additional security, we strongly recommend that all dressers in your home be anchored; all Delta Children dressers include a wall anchor.





# LEADERS EN MATIÈRE DE SÉCURITÉ

Visitez [Deltachildren.Com/Pages/Leaders-In-Safety](https://Deltachildren.Com/Pages/Leaders-In-Safety) pour plus d'informations

## MATÉRIAUX SURS

Les produits surs sont faits à partir de matériaux surs. Nous testons tous nos produits pour créer l'environnement le plus sûr et plus sain pour votre bébé.



## DES PRODUITS FIABLES

Nous possédons 8 laboratoires de pointe en matière de sécurité où nous testons nos produits au delà des standards industriels. Toutes nos commodes sont conçues pour être aux normes selon les standards de sureté des meubles ASTM et même les dépasser.



## NOUS ALLONS AU-DELÀ

Pour protéger vos enfants, les commodes de Delta Children sont testées pour satisfaire les exigences du test industriel de basculement indiqué par ASTM. Pour une sécurité additionnelle, nous recommandons fortement l'ancrage de toutes les commodes dans votre maison; toutes les commodes de Delta Children incluent une fixation pour le mur.





# LÍDERES EN LA SEGURIDAD

Visite [Deltachildren.Com/Pages/Leaders-In-Safety](http://Deltachildren.Com/Pages/Leaders-In-Safety) para más información

## MATERIALES SEGUROS

Los productos seguros se hacen con materiales seguros. Ponemos a prueba todos nuestros productos para crear el ambiente más seguro y saludable para su bebé.



## PRODUCTOS CONFIABLES

Tenemos 8 laboratorios de seguridad de alta tecnología donde probamos nuestros productos mas allá de los estándares de la industria. Todos nuestros tocadores están diseñados para cumplir o exceder los estándares de seguridad ASTM de muebles.



## ESTAMOS POR ENCIMA Y MÁS ALLÁ

Para proteger a sus niños, los tocadores de Delta Children son sometidos a pruebas para que cumplan los requisitos ASTM establecidos de la industria en cuanto a volcamientos se refiere.

Para seguridad adicional, recomendamos enfáticamente que todos los tocadores de su casa estén fijos: todos los tocadores de Delta Children incluyen un anclaje de pared.







# POURQUOI CHOISIR POR QUÉ ELEGIR A DELTA CHILDREN?

Visitez [Deltachildren.Com/Pages/Our-Story](http://Deltachildren.Com/Pages/Our-Story) pour plus d'information

Visita [Deltachildren.Com/Pages/Our-Story](http://Deltachildren.Com/Pages/Our-Story) para más información

<p><b>DELTA EN TÊTE</b> Un enfant sur deux aux U.S.A. dort dans nos produits</p>	<p><b>DELTA DONNE</b> 10% de nos revenus sont dédiés à l'amélioration de la vie des enfants</p>	<p><b>DELTA PREND SOIN</b> Nous testons la conformité au-delà des standards de sécurité de l'industrie</p>	<p><b>DELTA EST DÉVOUÉ</b> familiale a été présente pour votre famille depuis 1968</p>	<p><b>DELTA GRANDIT AVEC VOUS</b> Nous avons des produits pour chaque âge et chaque étape</p>	<p><b>Plus De 50 Ans De Sécurité, Design &amp; Innovation</b></p>
<p><b>DELTA LIDERA</b> 1 de cada 2 niños en los EE.UU duerme en nuestros productos</p>	<p><b>DELTA DONA</b> 10% de nuestros ingresos está destinado a mejorar la vida de los niños</p>	<p><b>A DELTA LE IMPORTA</b> Hacemos pruebas por encima de los estándares de seguridad de la industria</p>	<p><b>DELTA ESTÁ DEDICADA</b> Nuestra empresa familiar ha estado siempre presente para su familia desde 1968</p>	<p><b>DELTA CRECE CON USTEDES</b> Tenemos productos para cada edad y etapa</p>	<p><b>Más De 50 Años De Seguridad, Estilo E Innovación</b></p>

Bienvenue dans la **FAMILLE DELTA**  
Voici Notre Cadeau Pour Vous

Bienvenido a la **FAMILIA DELTA**  
Aquí Está Nuestro Regalo Para Usted

# 10% OFF

Votre Prochain Achat Chez  
Su Próxima Compra En  
**DeltaChildren.com**

UTILISEZ LE CODE:  
UTILICE EL CÓDIGO:  
**DELTA10**

\*Des exclusions s'appliquent  
\*Sujet à changement

\*Exclusions Apply  
\*Subject to Change

## DES PRODUITS POUR CHAQUE ÂGE ET CHAQUE ÉTAPE PRODUCTOS PARA CADA EDAD Y ETAPA



NOTRE FAMILLE DE MARQUES SUPÉRIEURES / NUESTRA FAMILIA DE LAS MEJORES MARCAS



PLUS DE 50 ANS DE SÉCURITÉ, DESIGN & INNOVATION / MAS DE 50 ANOS DE SEGURIDAD, ESTILO E INNOVACIÓN





# WHY CHOOSE DELTA CHILDREN?

Visit [Deltachildren.Com/Pages/Our-Story](http://Deltachildren.Com/Pages/Our-Story) for more information

<p><b>DELTA LEADS</b> 1 Out Of 2 Children In The U.S. Sleep In Our Products</p>	<p><b>DELTA GIVES</b> 10% Of Our Profits Go Toward Improving The Lives Of Children</p>	<p><b>DELTA CARES</b> We Test Above &amp; Beyond Industry Safety Standards</p>	<p><b>DELTA IS DEDICATED</b> Our Family-Run Company Has Been There For Your Family Since 1968</p>	<p><b>DELTA GROWS WITH YOU</b> We Have Products For Every Age And Stage</p>	<p>Over 50 Years Of Safety, Style &amp; Innovation</p>
---	--	--	---	---	--

Welcome to the  
**DELTA FAMILY**  
Here's a Gift From Us To You

**10% OFF**

Your Next Purchase From  
[DeltaChildren.com](http://DeltaChildren.com)

USE CODE:  
**DELTA10**

\*Exclusions Apply  
\*Subject to Change

## PRODUCTS FOR EVERY AGE AND STAGE

					
CRIBS LITS POUR BÉBÉ CUNAS	STROLLERS ÉQUIPEMENT POUR BÉBÉ COSAS PARA BÉBÉ	GLIDERS CHAISE SILLA	BASSINETS COUFFINS MOISÉS	MATRESSES MATELAS COLCHÓN	
					
BABY GEAR POUSSETTES CARRIOLAS	TODDLER BEDS LITS POUR ENFANT CAMA PARA NIÑO	PLAYROOM FURNITURE SALLE DE JEUX CUARTO DE JUGAR	TWIN BEDS LITS UNE PLACE CAMA SENCILLA	BINS & ORGANIZERS PANIERES CONTENEDORES	DRESSERS COMMODES TOCADORES

## OUR FAMILY OF TOP BRANDS



OVER 50 YEARS OF SAFETY, STYLE, AND INNOVATION

