



Read all instructions before assembly and use.
KEEP INSTRUCTIONS FOR FUTURE USE.

Lisez toutes les instructions avant l'assemblage et l'utilisation.
CONSERVEZ LES INSTRUCTIONS POUR UN USAGE ULTERIEUR.

Lea todas las instrucciones antes de ensamblar y usar.
MANTENGA LAS INSTRUCCIONES PARA SU USO FUTURO.



3 Drawer Chest
Commode à 3 Tiroirs
Cómoda con 3 Gavetas

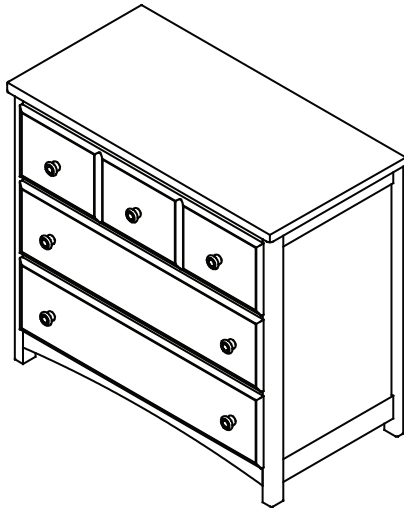

Style #: _____
 Lot: _____
 Date: _____

⚠ ADULT ASSEMBLY REQUIRED
Due to the presence of small parts during assembly, keep out of reach of children until assembly is complete.

⚠ L'ASSEMBLAGE DOIT ETRE FAIT PAR UN ADULTE
A cause de la presence de petites pieces, pendant l'assemblage gardez hors de portee des enfants jusqu'a ce que celui-ci soit termine.

⚠ DEBE SER ENSAMBLADO POR UN ADULTO
Debido a la presencia de piezas pequeñas durante el ensamblaje, mantenga fuera del alcance de los niños hasta que complete el ensamblaje.

This product is not intended for institutional or commercial use.
Ce produit ne pas destine a un usage institutionnel ou commercial.
Este producto no esta hecho para uso institucional o comercial.

NEED EXTRA HELP?

We make assembly easy with our tips & tricks video
<https://www.deltachildren.com/pages/instructions>

BESOIN D'AIDE SUPPLÉMENTAIRE?

Nous facilitons l'assemblage avec nos trucs et astuces vidéo
<https://www.deltachildren.com/pages/instructions>

¿NECESITA AYUDA EXTRA?

Hacemos el montaje fácil con nuestros consejos y trucos video
<https://www.deltachildren.com/pages/instructions>

When contacting Delta Consumer Experience Center please reference the above information. Before contacting Delta Consumer Experience Center please ensure that the information above matches the information found on the label on the *Back Panel*, please reference the information found on the product when contacting Delta Consumer Experience Center.

Lorsque vous contactez le Service client de Delta, veuillez faire référence aux informations ci-dessus. Avant de contacter le Service client de Delta, veuillez vous assurer que les informations ci-dessus correspondent aux informations indiquées sur l'étiquette qui se trouve sur *panneau arrière*; veuillez faire référence aux informations indiquées sur le produit lorsque vous contactez le Service client de Delta.

Al contactar al servicio al cliente de Delta, entregue la información anteriormente mencionada. Antes de contactar al servicio de atención al cliente de Delta, asegúrese de que la información anteriormente mencionada calza con la que aparece en la etiqueta en *panel trasero*; al contactar al centro de atención al cliente de Delta, mencione la información que aparece en el producto.

CONSUMER EXPERIENCE CENTER

Delta Children's Products Corp | 114 West 26th Street New York, NY 10001
(646) 435-8727 | wcs@DeltaChildren.com | www.DeltaChildren.com



BABY SAFE SLEEP TIPS

Visit Deltachildren.Com/Pages/Crib-Safety-Tips for more information



Read all warnings and follow all instructions.



DO NOT place any items in the crib.



The safest place for your baby to sleep is in a JPMA Certified crib.



Pillows and blankets have caused infants to suffocate, **NEVER** use in a crib.

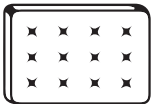

Your baby should sleep on a firm mattress.



NEVER place the crib near a window or any wall hangings.



Adult beds are not safe for babies: **NEVER** co-sleep.



Missing or broken parts, any questions? **CALL** Delta Children Consumer Care.



AAP Recommends: Always lay your baby on its back to sleep. Consult your doctor.





FURNITURE SAFETY TIPS

Visit Deltachildren.Com/Pages/Leaders-In-Safety for more information

**SERIOUS OR FATAL CRUSHING INJURIES
CAN OCCUR FROM FURNITURE TIP-OVER.**



Read all warnings and follow all instructions.



NEVER open more than one drawer at a time.



ALWAYS use provided tipover restraints.



DO NOT leave drawers open when not in use.



DO NOT set TV's or other heavy objects on the top of bedroom or nursery furniture.



NEVER allow children to climb or hang on drawers, doors, or shelves.



Place heaviest items in the lowest drawers.



Missing or broken parts, any questions? **CALL** Delta Children Consumer Care.



CONSEILS POUR FAIRE DORMIR VOTRE BÉBÉ EN TOUTE SÉCURITÉ

Visitez Deltachildren.Com/Pages/Crib-Safety-Tips pour plus d'information



Lisez tous les avertissements et respectez toutes les consignes de sécurité.



NE déposez aucun objet dans le Lit de Bébé



L'endroit le plus sûr pour faire dormir votre bébé, c'est dans un Lit de Bébé approuvé par JPMA.



Des oreillers et couvertures ont parfois été responsables d'étouffements de nourrissons. **N'** en utilisez **JAMAIS** dans un lit de bébé.

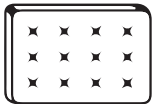

Votre bébé doit dormir sur un matelas ferme.



NE placez **JAMAIS** le Lit de Bébé à proximité d'une fenêtre ou de tentures.



Les lits d'adultes ne sont pas un lieu sûr pour les bébés: **NE** dormez **JAMAIS** ensemble.



Des pièces manquantes ou cassées? **APPELEZ** Delta Children Consumer Care.



Conseils de l'AAP: Placez toujours votre bébé sur le dos pour dormir. Consultez votre médecin.





CONSEILS DE SÉCURITÉ RELATIFS AUX MEUBLES

Visitez Deltachildren.Com/Pages/Leaders-In-Safety pour plus d'information

LE RENVERSEMENT DU MEUBLE PEUT ENTRAÎNER DES BLESSURES GRAVES OU MORTELLES.



Lisez tous les avertissements et respectez toutes les consignes de sécurité.



N'OUVREZ JAMAIS plus d'un tiroir en même temps



Utilisez **TOUJOURS** les dispositifs de non-renversement fournis.



NE laissez **PAS** les tiroirs ouverts lorsque vous ne les utilisez pas.



NE déposez **PAS** de postes de télévision ou d'autres objets lourds sur des meubles de chambre à coucher ou de chambre d'enfants.



NE laissez **JAMAIS** les enfants monter sur ou se suspendre aux tiroirs, portes et ou tablettes.



Placez les objets les plus lourds dans les tiroirs du bas.



Des pièces manquantes ou cassées? **APPELEZ** Delta Children Consumer Care.



CONSEJOS PARA UN SUEÑO SEGURO PARA LOS BEBÉS

Visite Deltachildren.Com/Pages/Crib-Safety-Tips para obtener más información



Lea todas las advertencias y siga todas las instrucciones.



NO coloque artículos en la cuna.



El lugar más seguro para que su bebé duerma es una cuna con certificación JPMA.



Las almohadas y frazadas han provocado asfixia en menores; por lo tanto, **JAMÁS** se deben utilizar en una cuna.



Su bebé debe dormir sobre un colchón firme.



NEVER place the crib near a window or any wall hangings.



Las camas para adultos no son seguras para los bebés: **JAMÁS** duerma con ellos.



¿Le faltan piezas o vienen rotas? **LLAME** al Delta Children Consumer Care.



APP recomienda: Haga que su bebé duerma siempre boca arriba. Consulte a su médico.





CONSEJOS DE SEGURIDAD SOBRE MUEBLES

Visite Deltachildren.Com/Pages/Leaders-In-Safety para obtener más información

**PUEDEN PRODUCIRSE LESIONES GRAVES O MORTALES POR
APLASTAMIENTO AL VOLCARSE MUEBLES.**



Lea todas las advertencias y siga todas las instrucciones.



NUNCA abra más de un cajón al mismo tiempo.



Utilice **SIEMPRE** las retenciones contra volcamiento incluidas



NO DEJE cajones abiertos si no los está utilizando.



NO posicione televisores u otros objetos pesados sobre la cama o muebles para infantes.



NUNCA permita que los niños trepen sobre cajones, puertas o baldas de estantería ni que se cuelguen de ellos.



Coloque los artículos de mayor peso en los cajones inferiores.



¿Le faltan piezas o vienen rotas? **LLAME** al Delta Children Consumer Care.



SAVE BIG WITH DELTA CHILDREN

Visit Deltachildren.com To Start Shopping

Welcome to the
DELTA FAMILY
Here's a Gift From Us To You

10% OFF

Your Next Purchase From
DeltaChildren.com

USE CODE:
DELTA10

*Exclusions Apply
*Subject to Change

REVIEW TO WIN \$2500

RULES TO ENTER

★ ★ ★ ★ ★

"We LOVE, LOVE, LOVE this crib"

My husband was impressed with the directions and organization of the hardware package. He easily assembled this crib in an hour without any help. It's very sturdy and we like that it has adjustable levels for the mattress height. To top it all off, it's so incredibly darling!!!

- 1** **WRITE A REVIEW** for this product on the store's website from where it was purchased
- 2** **TAKE A SCREENSHOT** of your review and upload it to www.DeltaChildren.com/Review
- 3** **IT'S THAT EASY!** Upon submission, you'll be instantly **ENTERED TO WIN \$2,500**

FOLLOW US FOR MORE CHANCES TO WIN

@deltachildren

SCAN HERE



For more information & to see all of our products





ÉCONOMISEZ BEAUCOUP AVEC AHORRE MUCHO CON DELTA CHILDREN

Visitez Deltachildren.com Pour Commencer Vos Achats
Visita Deltachildren.com Para Comenzar A Comprar

Bienvenue dans la
FAMILLE DELTA
Voici Notre Cadeau Pour Vous
Bienvenido a la
FAMILIA DELTA
Aquí Está Nuestro Regalo Para Usted

10% OFF

Votre Prochain Achat Chez
Su Próxima Compra En
DeltaChildren.com

UTILISEZ LE CODE:
UTILICE EL CÓDIGO:
DELTA10

*Des exclusions s'appliquent
*Sujet à changement

*Exclusions Apply
*Subject to Change

LAISSEZ UN COMMENTAIRE CLIENT POUR **GAGNER \$2500**
CALIFIQUE EL PRODUCTO PARA **GANAR \$2500**

REGLEMENT DE PARTICIPATION / REGLAS PARA PARTICIPAR

- 1** ECRIVEZ UN COMMENTAIRE CLIENT pour ce produit sur le site web du magasin où il a été acheté
CALIFIQUE EL PRODUCTO en la página web de la tienda donde haya sido comprado
- 2** FAITES UNE CAPTURE D'ECRAN de votre commentaire client et mettez la en ligne sur www.DeltaChildren.com/Review
HAGA UNA CAPTURA DE PANTALLA de su calificación y cárguela a la pagina www.DeltaChildren.com/Review
- 3** C'EST AUSSI SIMPLE QUE ÇA! Dès que c'est fait vous serez instantanément **INSCRIT POUR GAGNER 2500\$**
ES ASÍ DE FÁCIL! En cuanto lo envíe ya estará instantáneamente **PARTICIPANDO PARA GANAR \$2.500**

SUIVEZ NOUS POUR AVOIR PLUS DE CHANCES DE GAGNER /
SÍGANOS PARA TENER MAS CHANCES DE GANAR



@deltachildren

SCANNEZ ICI / ESCANEE AQUÍ



Pour plus d'informations et
pour voir tous nos produits

Para más información y para
ver todos nuestros productos



⚠ WARNING



Serious or fatal crushing injuries can occur from furniture tip-over. To help prevent tip-over:

- Install tipover restraint provided.
- Place heaviest items in the lowest drawers.
- Do not set TV's or other heavy objects on top of this product, unless the product is specifically designed to accommodate them.
- Never allow children to climb or hang on drawers, doors, or shelves.
- Never open more than one drawer at a time.



Use of tip-over restraints may only reduce, but not eliminate, the risk of tip-over.

⚠ AVERTISSEMENT



Des blessures sérieuses ou mortelles dues à un écrasement peuvent survenir lorsqu'un meuble bascule. Pour prévenir ces accidents:

- Installez le dispositif anti bascule fourni.
- Placez les articles les plus lourds dans les tiroirs inférieurs.
- Ne PAS poser une TV ou autres objets lourds sur ce produit à moins que le produit soit spécifiquement conçu pour les recevoir.
- Ne jamais permettre à un enfant de grimper ou s'accrocher aux tiroirs, portes ou étagères.
- Ne jamais ouvrir plus d'un tiroir à la fois



L'utilisation du système anti-basculement peut seulement diminuer mais pas complètement éliminer le risque de basculement.

⚠ ADVERTENCIA



Pueden producirse lesiones graves o mortales por aplastamiento al volcarse muebles. Para evitar vuelcos:

- Instalar el dispositivo anti-vuelcos que viene incluido.
- Coloque los artículos de mayor peso en los cajones inferiores.
- No coloque televisores ni ningún otro objeto pesado encima de este producto, a menos de que el producto esté específicamente diseñado para ese propósito.
- Nunca permita que los niños trepen sobre cajones, puertas o baldas de estantería ni que se cuelguen de ellos.
- Nunca abra más de un cajón al mismo tiempo.



El uso de herramientas de contención de vuelcos tan solo puede reducir, pero no eliminar, el riesgo de vuelco.

NOTES ON ASSEMBLY:

-During the assembly process whenever using screws or bolts, check each by placing the screw/bolt on the diagram of the item which is drawn actual size and design. Be sure to use the proper size and shape specified in the instructions.

-To assemble this unit you may be required to place the unit on it's side and face. It is strongly recommended that assembly is done on a soft, non-abrasive surface to avoid damaging the finish.

NOTES ON CARE AND MAINTENANCE:

- **Do not** scratch or chip the finish.

- Inspect the product periodically, contact Delta Children's Products for replacement parts or questions.

- **Do not** store the product or any parts in extreme temperatures and conditions such as a hot attic or a damp, cold basement. These extremes can cause a loss of structural integrity.

-To preserve the luster of the high quality finish on your product, it is recommended to place a doily or felt pad under any items you place on the finish.

-Clean with a damp cloth, then a dry cloth to preserve the original luster and beauty of this fine finish.

-**Do not** use abrasive chemicals.

-**Do not** spray cleaners directly onto furniture.

-Lift slightly when moving on carpeting to prevent leg breakage.

-Use of a vaporizer near furniture will cause wood to swell and finish to peel.

REMARQUES SUR L'ASSEMBLAGE :

-Lors de l'assemblage, quand vous utilisez vis ou boulons, vérifiez chaque pièce en plaçant le vis/boulon sur le diagramme de la pièce concernée qui est dessinée en taille et forme réelle. Assurez-vous d'utiliser la taille et la forme exacte comme il est spécifié dans les instructions.

-Pour assembler cet élément vous pourriez avoir besoin de le placer sur le côté latéral et sur le côté frontal. Il est fortement recommandé de faire l'assemblage sur une surface lisse, non abrasive (comme le film mousse de l'emballage) pour éviter d'endommager les finitions.

REMARQUES SUR LE SOIN ET L'ENTRETIEN:

-**Ne pas** rayer ou ébrécher la finition.

-Examinez de près le produit régulièrement, contactez Delta Children's Products pour les pièces de rechange ou pour poser des questions.

-**Ne pas** ranger le produit ou des pièces à des températures extrêmes ou dans des conditions comme un grenier chaud ou une cave froide et humide. Ces extrêmes peuvent causer une perte de l'intégrité de la structure du produit.

-Pour préserver le lustre original et la beauté de ce fini raffiné nettoyez avec un chiffon humide, puis un chiffon sec.

-**Ne pas** utiliser des produits chimiques abrasifs.

-**Ne pas** pulvériser un nettoyant directement sur le meuble, pulvériser sur le torchon et puis appliquer sur le meuble. Testez le produit nettoyant sur un endroit discret avant de l'utiliser sur la totalité du meuble.

-Lors d'un déplacement sur une moquette ou tapis, soulevez légèrement le meuble pour éviter de casser les pieds.

-L'utilisation d'un vaporisateur près du meuble causera le gonflement du bois et l'écaillage de la finition.

INFORMACIÓN SOBRE EL MONTAJE:

-Durante el proceso de montaje, ya utilice pernos o tornillos, compruebe cada uno de ellos colocando el perno/tornillo en el diagrama del artículo donde está dibujado el tamaño y el diseño real. Asegúrese de que utiliza el tamaño y la forma adecuada que especifican las instrucciones.

-Para montar esta unidad, puede que se le solicite que coloque la unidad de lado y de cara. Se recomienda encarecidamente que realice el montaje sobre una superficie no abrasiva (Como la envoltura de embalaje de espuma) para evitar dañar el acabado.

NOTAS SOBRE SU CUIDADO Y MANTENIMIENTO:

- **No** arañe ni desconche el acabado.

- Inspeccione el producto con regularidad, póngase en contacto con Delta Children's Products para el recambio de partes o para formular preguntas.

- **No** guarde el producto ni ninguna de sus partes a temperaturas ni en condiciones extremas como un ático caluroso o un sótano húmedo y frío. Estos extremos pueden provocar una pérdida de integridad estructural.

-Para preservar el brillo del acabado de alta calidad que recubre su producto, se recomienda que coloque un paño o una almohadilla de fieltro debajo de cualquier objeto que coloque sobre el acabado.

-Límpielo con un trapo húmedo y luego con uno seco para preservar el brillo y la belleza originales de este fino acabado.

-**No** utilice productos químicos abrasivos.

-**No** pulverice limpiadores directamente sobre el mueble.

-Elevéelo ligeramente cuando lo mueva sobre alfombras o moqueta para evitar que se rompan las patas.

-El uso de vaporizadores cerca de muebles puede provocar que la madera se hinche y acabe desconchándose.



PARTS: MAKE SURE THAT ALL PRE-ASSEMBLED PARTS ARE TIGHT
 PIÈCES : VÉRIFIEZ QUE TOUTES LES PIÈCES PRÉ-MONTÉES SONT BIEN SERRÉES.
 PIEZAS: ASEGÚRESE DE QUE TODAS LAS PIEZAS PRE-ENSAMBLADAS ESTÁN BIEN APRETADAS.

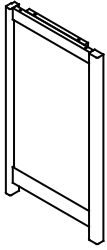

J. Left Side x1
 Côté gauche
 Lado izquierdo
 #40018

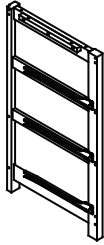

K. Right Side x1
 Côté droit
 Lado derecho
 #40017

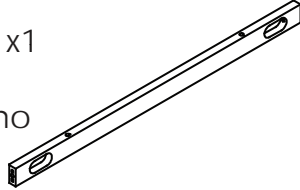

N. Top Front Rail x1
 Barre Avant Supérieur
 Barra Frontal Superior
 #27960

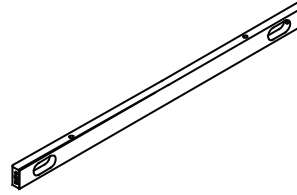

M. Top Back Rail x1
 Barre Arrière Supérieur
 Barra Trasero Superior
 #27959

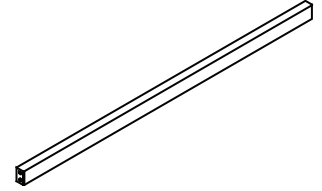

T. Drawer Rail x 2
 Barre de tiroir
 Barra de la gaveta
 #21453

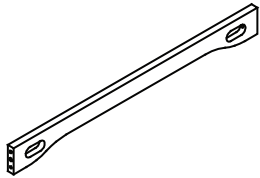

R. Bottom Front Rail x1
 Barre Avant Inférieur
 Barra Frontal Inferior
 #27965

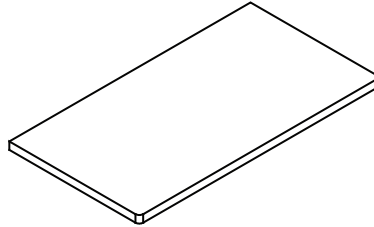

L. Top Panel x1
 Panneau avant
 Panel superior
 #40016

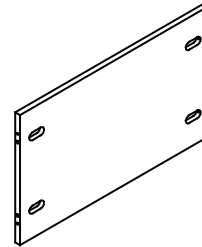

P. Bottom Back Rail x1
 Barre arrière inférieur
 Barra trasero inferior
 #27964

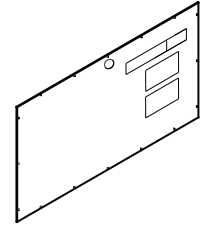

U. Back Panel x1
 Panneau arrière
 Panel trasero
 #27961

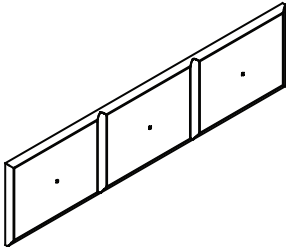

AA. Drawer Front-Vein Line x1
 Avant du tiroir-aspect veiné
 Parte frontal de la Gaveta
 # 40384

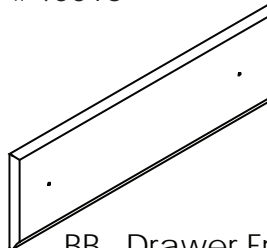

BB. Drawer Front x 2
 Avant du tiroir
 Parte frontal de la Gaveta
 # 40385

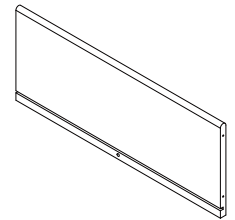

CC. Drawer Back x 3
 Arrière du tiroir
 Trasera de la gaveta
 # 40386

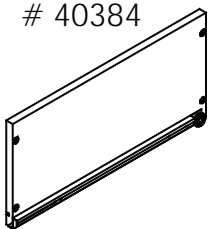

DD. Drawer Right Side x 3
 Côté droit du tiroir
 Lado Derecho de la Gaveta
 # 40387

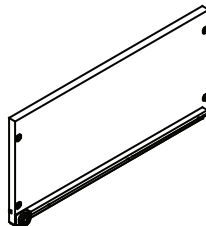

EE. Drawer Left Side x 3
 Côté gauche du tiroir
 Lado Izquierdo de la Gaveta
 # 40388



GG. Drawer Support x3
 Support du tiroir
 Soporte de la gaveta
 #29861

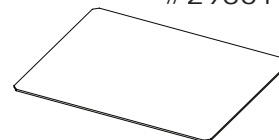

FF. Drawer Bottom x 3
 Fond de tiroir
 Fondo de la gaveta
 # 40389





Parts: Hardware kits part#40019

Pièces: L'ensemble de quincaillerie - pièce n°40019

Piezas: El kit de herramientas - Pieza #40019

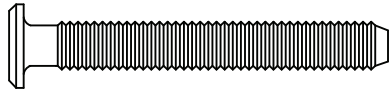
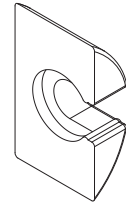

A. M6 x 50mm Bolt x14
Boulon M6 x 50mm
Perno M6 x 50mm

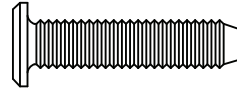

B. M6 x 28mm Bolt x4
Boulon M6 x 28mm
Perno M6 x 28mm

C. Crescent Washer x 10
Rondelle en Croissant
Arandela de Media Luna

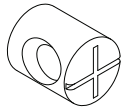

E. Plastic Barrel Nut x15
Écrou à portée cylindrique
en plastique
Tuercacilíndricaplástica

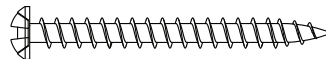

P. 40mm SCREW x15
Vis 40mm
Tornillo 40mm

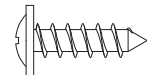

F. 16mm Back Panel Screw x16
Vis 16mm pour Panneau Arrière
Tornillo 16mm de Panel Trasero

G. Knob / Bouton / Perilla x7
#26349

G1. Knob
Bouton
Perilla

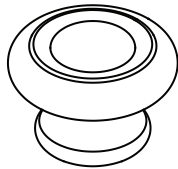

G2. 25mm Knob Screw
Vis de Bouton
Tornillo para Perilla



D. Φ 6x30mm Wood Dowel x28
Cheville en bois Φ 6x30mm
Pasador de madera Φ 6x30mm

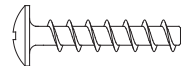

H. 20mm Screw x12
Vis 20mm
Tornillo 20mm

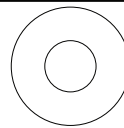

TT. Washer x2
Rondelle
Arandela

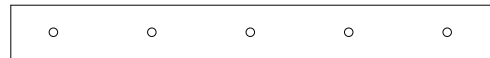

ZZ. (1) Wall Strap/Sangle murale/Abrazadera

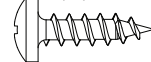

YY. Short Screw x1
Vis Court
Tornillo corto

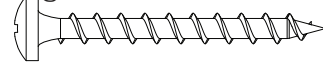

XX. Long Screw x1
Vis Longue
Tornillo Largo

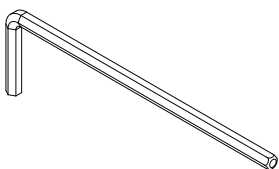

M4 Allen Wrench
Clé Allen M4
Llave Allen M4

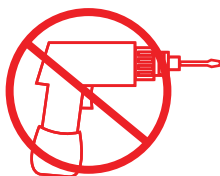

CAUTION: Do Not use a power screwdriver they can cause screws to break or strip.

ATTENTION: Ne Pas utiliser un tournevis électrique car les vis peuvent casser ou perdre leurs filets.

ATENCIÓN: No use un destornillador eléctrico ya que puede causar que los tornillos se rompan o rueden.



Phillips Screwdriver - Not included
Tournevis Phillips - non inclus
Destornillador Phillips - no incluido

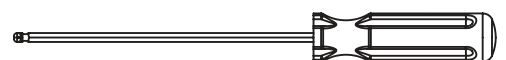

M4 Ballend Screwdriver
tournevis M4 à tête sphérique
destornillador M4 con cabeza de bola





Hardware System - Review Before Assembly
Quincaillerie – Lire Avant D’effectuer Le Montage
Revise Antes De Armar- Elementos De Fijacion Y Ensamble

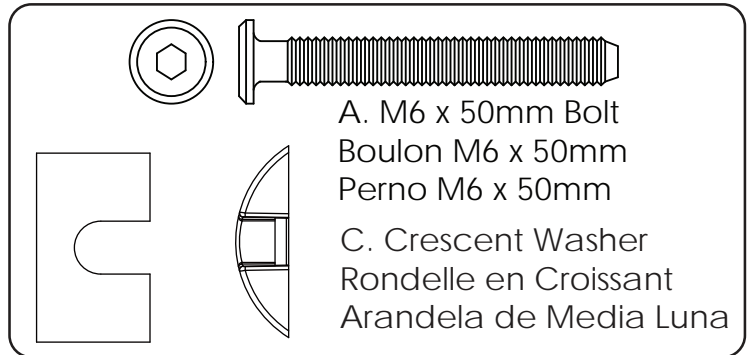
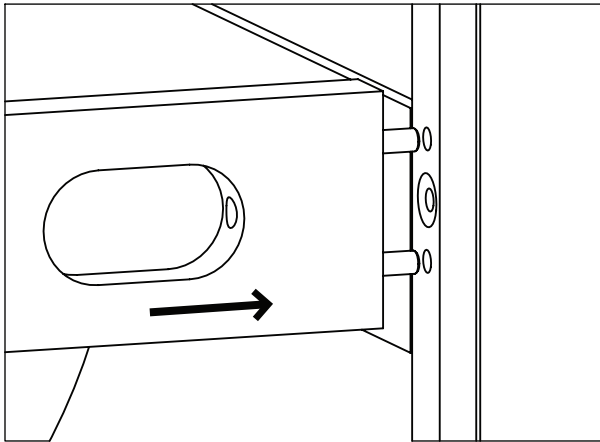

1. Insert the Dowels in the Rail into the holes in the Post.
 1. Insérer les chevilles dans le rail dans les orifices dans le poteau.
 1. Inserte los pasadores del Riel en los agujeros del Poste.

2. Insert the Bolt into the slot. Turn clockwise with fingers or the Ball End Screwdriver provided. DO NOT fully tighten, leave 1/2" (12mm) exposed.

2. Insérez le boulon dans la fente. Tournez dans le sens des aiguilles d’une montre à l’aide des doigts ou de la tournevis à tête sphérique. Ne Pas serrer complètement et laissez 12 mm (1/2 pouces) exposés.

2. Inserte el perno en la ranura. Gírelo en el sentido de las agujas del reloj con los dedos o con el destornillador con cabeza de bola. NO lo apriete del todo, deje 1/2" (12 mm) fuera.

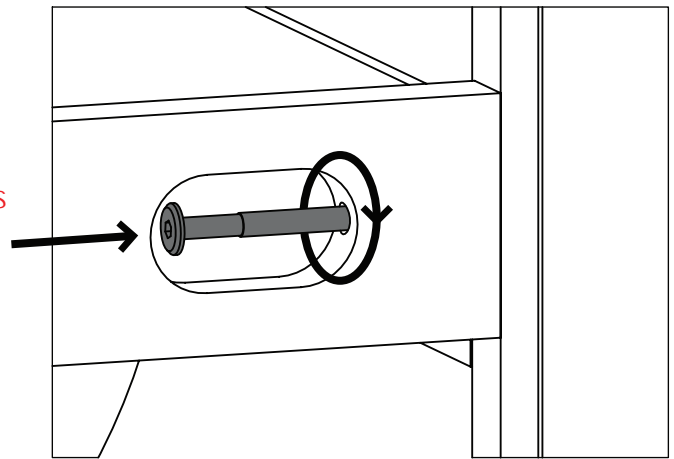

3. Slide the Crescent Washer over the exposed bolt, behind the head of the bolt.

3. Glissez la rondelle en croissant sur l’écrou exposé, derrière la tête de l’écrou.

3. Abrace la parte del Perno que quedó fuera, debajo de la cabeza del mismo, con la Arandela de media luna.

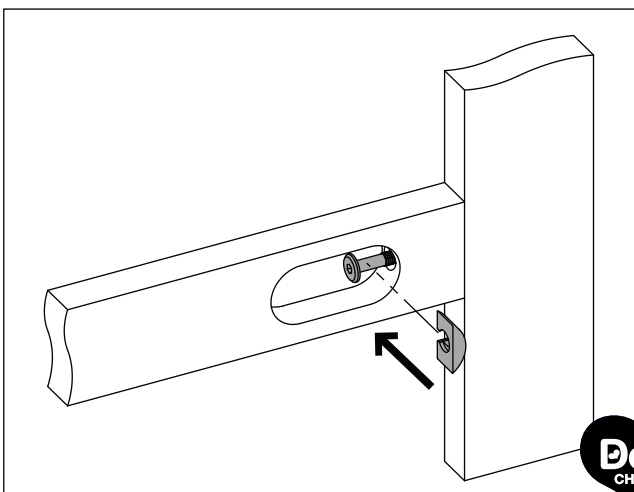



Install (1) bolt and (1) crescent washer at a time. Tighten until it looks like the picture.

Installez (1) boulon et (1) rondelle en croissant à la fois. Serrez jusqu'à ce que cela ressemble à l'image.

Instale (1) perno y (1) Arandela de media luna al mismo tiempo. Apriételos hasta que quede como en la ilustración.

Tighten the bolt with the ball end screwdriver.
Serrez à l'aide de la Tournevis à tête sphérique.
Apriételo con el Destornillador hcon cabeza de bola.

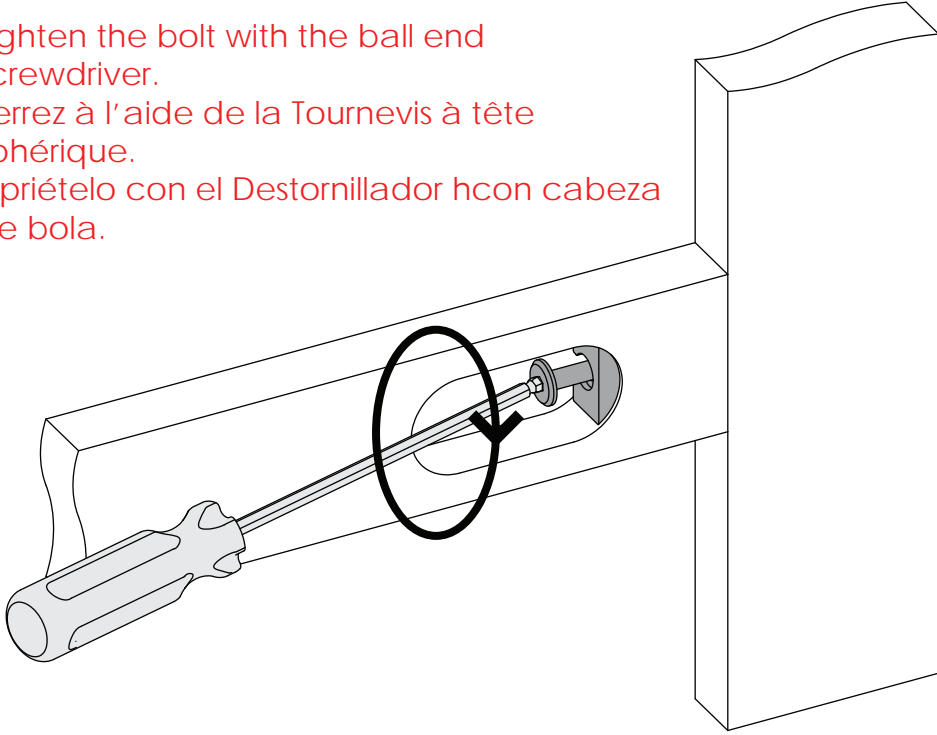

Ensure all bolts are tight with Allen wrench.
Serrez à l'aide de la clé Allen.
Apriételo con la llave Allen.

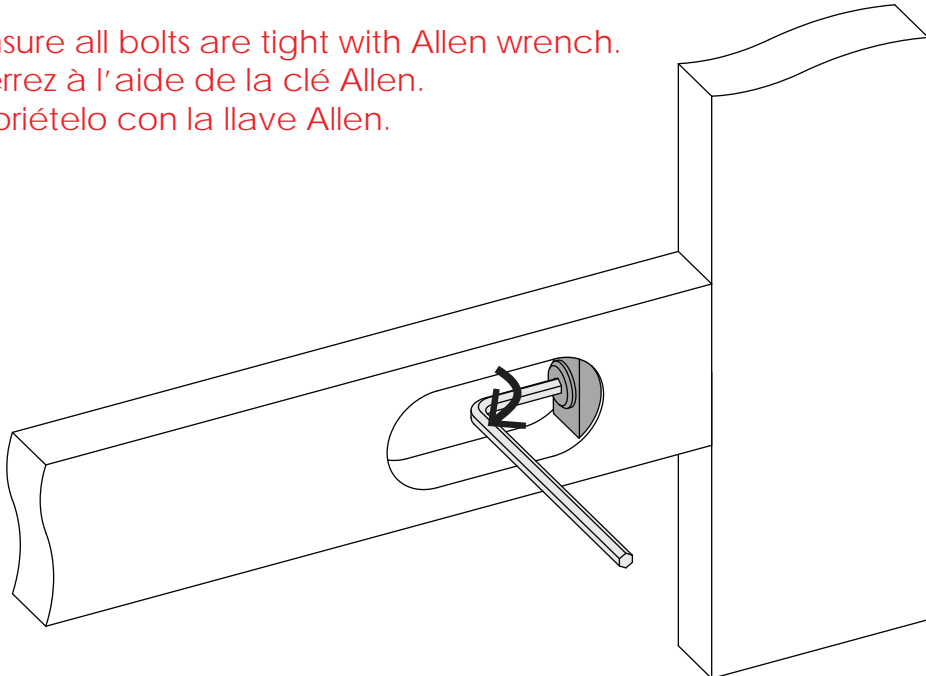



Step 1
Étape 1
Paso 1

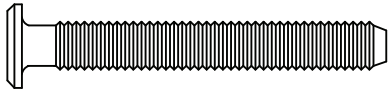

A. M6 x 50mm Bolt x 5
Boulon M6 x 50mm
Perno M6 x 50mm

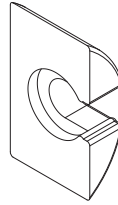

C. Crescent Washer x 5
Rondelle en Croissant
Arandela de Media Luna



D. Φ 6x30mm Wood Dowel x12
Cheville en bois Φ 6x30mm
Pasador de madera Φ 6x30mm

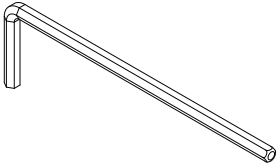

M4 Allen Wrench
Clé Allen M4
Llave Allen M4



M4 Ballend Screwdriver
tournevis M4 à tête sphérique
destornillador M4 con cabeza de bola

Attach Top Front Rail (Part N), Bottom Front Rail (Part R), Back Top Rail (Part M), Bottom Back Rail (Part P) and Drawer Rail (Part T), to the Left Side (Part J) using (12) 30mm Wood Dowels (Part D), (5) 50mm Bolts (Part A) and (5) Crescent Washers (Part C) following the instructions on page 14 & 15

Fixer le Barre avant supérieur (Pièce N), Barres Avant Inférieur (Pièce R), Barre arrière supérieur (Pièce M), Barre arrière inférieur (Pièce P) et les Barres de tiroir (Pièce T) au Côté Gauche (Pièce J) à l'aide de (12) Chevilles en bois 30mm (Pièce D), (5) boulons 50mm (Pièce A), et (5) Rondelles en croissant (Pièce C) à l'aide de du tournevis M4 à tête sphérique et la clé Allen M4 en suivant les instructions pages 14 et 15.

Fije la Barra frontal superior (Pieza N), las Barras Frontal Inferior (Pieza R), la Barra Trasero Superior (Pieza M), Barra trasero inferior (Pieza P) y las Barras de la gaveta (Pieza T) al Lado Izquierdo (Pieza J) utilizando (12) Pasadores de madera 30mm (Pieza D), (5) Pernos 50mm (Pieza A) y (5) Arandelas de Media Luna (Pieza C) utilizando el destornillador M4 con cabeza de bola y la llave Allen M4 siguiendo las instrucciones de las páginas 14 y 15.



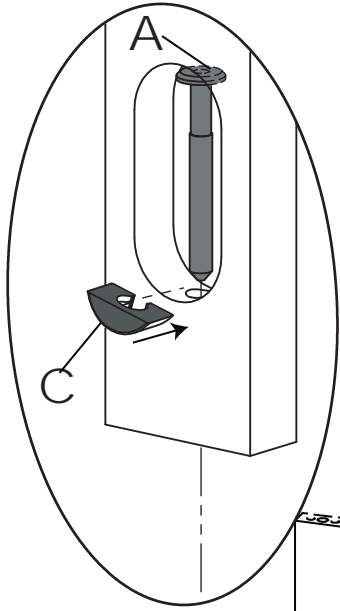

x5

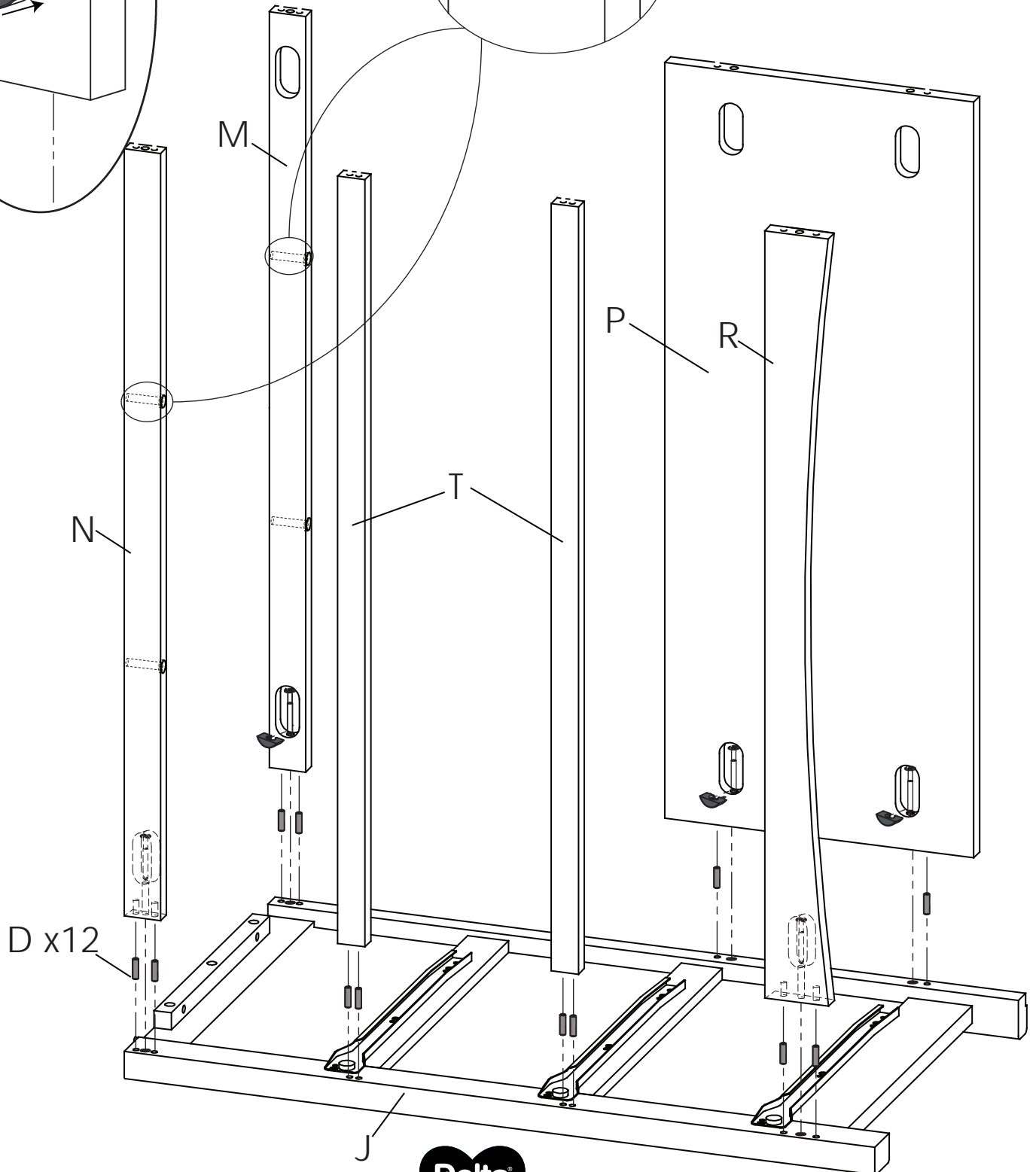
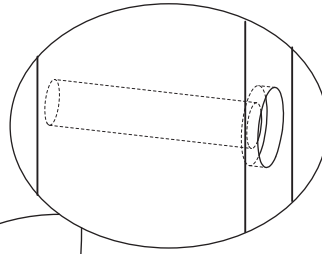



Step 2
Étape 2
Paso 2

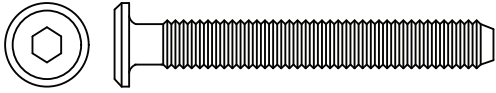

A. M6 x 50mm Bolt x 5
Boulon M6 x 50mm
Perno M6 x 50mm

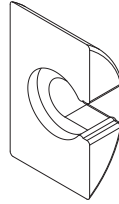

C. Crescent Washer x 5
Rondelle en Croissant
Arandela de Media Luna



D. Φ 6x30mm Wood Dowel x12
Cheville en bois Φ 6x30mm
Pasador de madera Φ 6x30mm

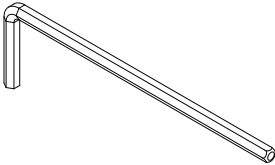

M4 Allen Wrench
Clé Allen M4
Llave Allen M4

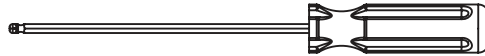

M4 Ballend Screwdriver
tournevis M4 à tête sphérique
destornillador M4 con cabeza de bola

Attach the Right Side (Part K) to the assembly from step 1 using (12) 30mm Wood Dowels (Part D), (5) 50mm Bolts (Part A) and (5) Crescent Washers (Part C) following the instructions on page 14&15.

Fixer le Dôté Droit (Pièce K) à l'ensemble monté à l'étape 1 à l'aide de (12) Chevilles en bois 30mm (Pièce D), (5) boulons 50mm (Pièce A), et (5) Rondelles en croissant (Pièce C) à l'aide de du tournevis M4 à tête sphérique et la clé Allen M4 en suivant les instructions pages 14 et 15.

Fije el Lado Derecho (Pieza K) al al conjunto de piezas del paso 1 utilizando (12) Pasadores de madera 30mm (Pieza D), (5) Pernos 50mm (Pieza A) y (5) Arandelas de Media Luna (Pieza C) utilizando el destornillador M4 con cabeza de bola y la llave Allen M4 siguiendo las instrucciones de las páginas 14 y 15.

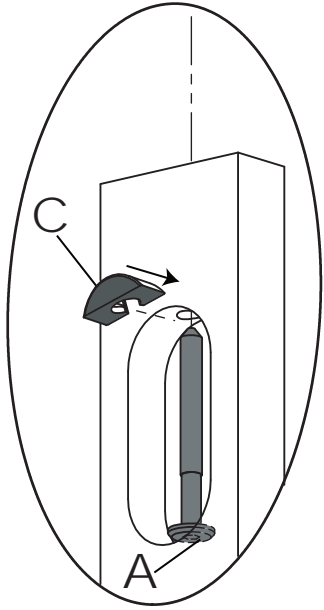

x5

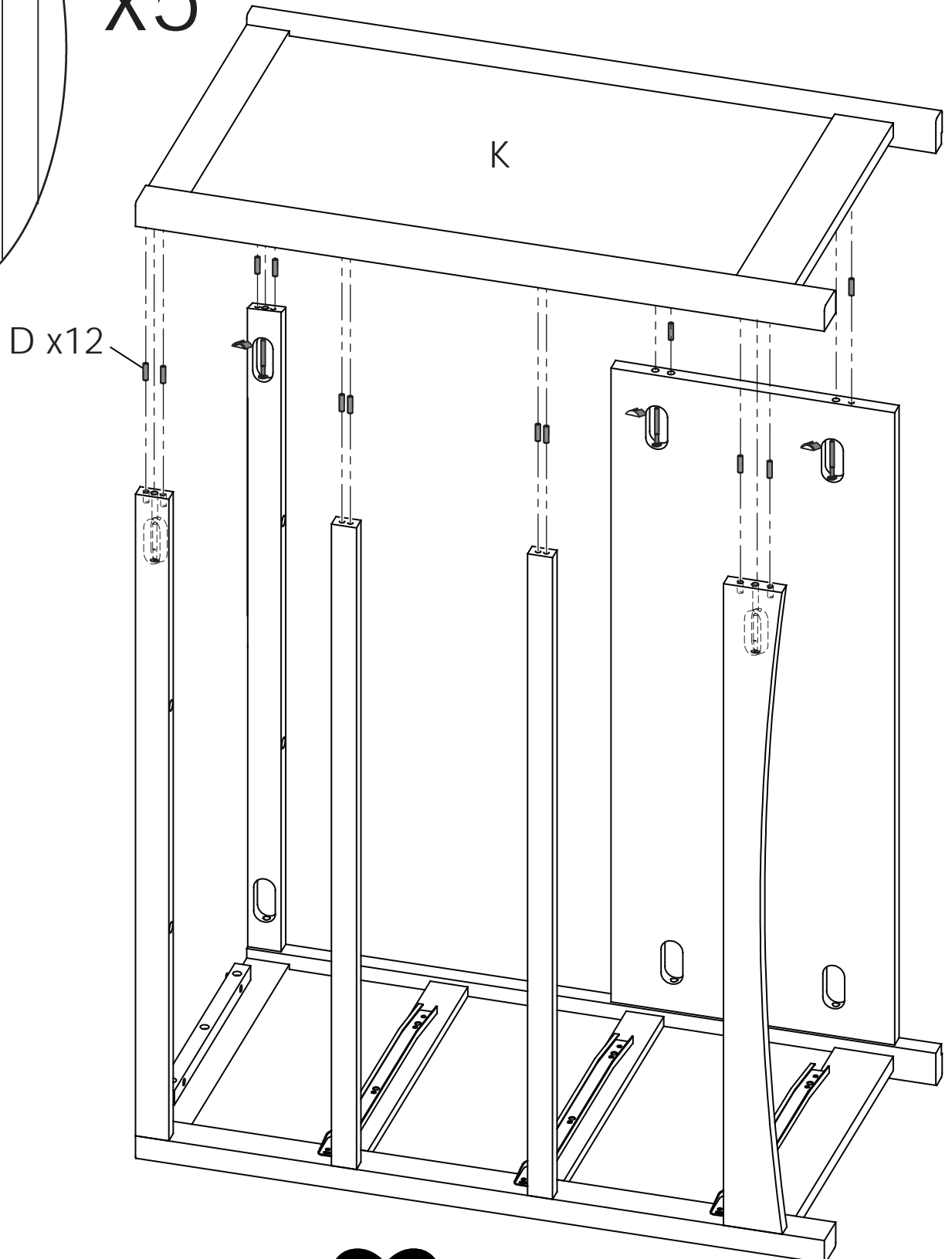



Step 3
Étape 3
Paso 3

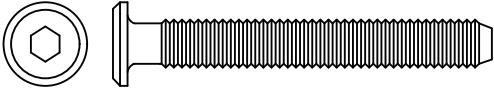

A. M6 x 50mm Bolt x 4
Boulon M6 x 50mm
Perno M6 x 50mm

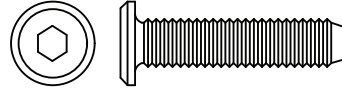

B. M6 x 28mm Bolt x4
Boulon M6 x 28mm
Perno M6 x 28mm



D. Φ 6x30mm Wood Dowel x 4
Cheville en bois Φ 6x30mm
Pasador de madera Φ 6x30mm



M4 Allen Wrench
Clé Allen M4
Llave Allen M4

Attach the Top Panel (Part L) to the assembly from Step 2 using (4) Wood Dowels (Part D), (4) 50mm Bolts (Part A) and (4) 28mm Bolts (Part B) . Tighten the Bolts with the M4 Ballend Screwdriver and M4 Allen wrench.

Fixer le Panneau Avant (Pièce L) au montage assemblé à l'étape 2 à l'aide de (4) Chevilles en bois (Pièce D), (4) Boulons 50 mm (Pièce A), et (4) Boulons 28mm (Pièce B) à l'aide de du tournevis M4 à tête sphérique et la clé Allen M4.

Fije el Panel Superior (Pieza L) al ensamblaje del Paso 2 utilizando (4) Pasadores de madera (Pieza D), (4) Pernos 50 mm (Pieza A) y (4) Pernos 28mm (Pieza B) utilizando el destornillador M4 con cabeza de bola y la llave Allen M4.

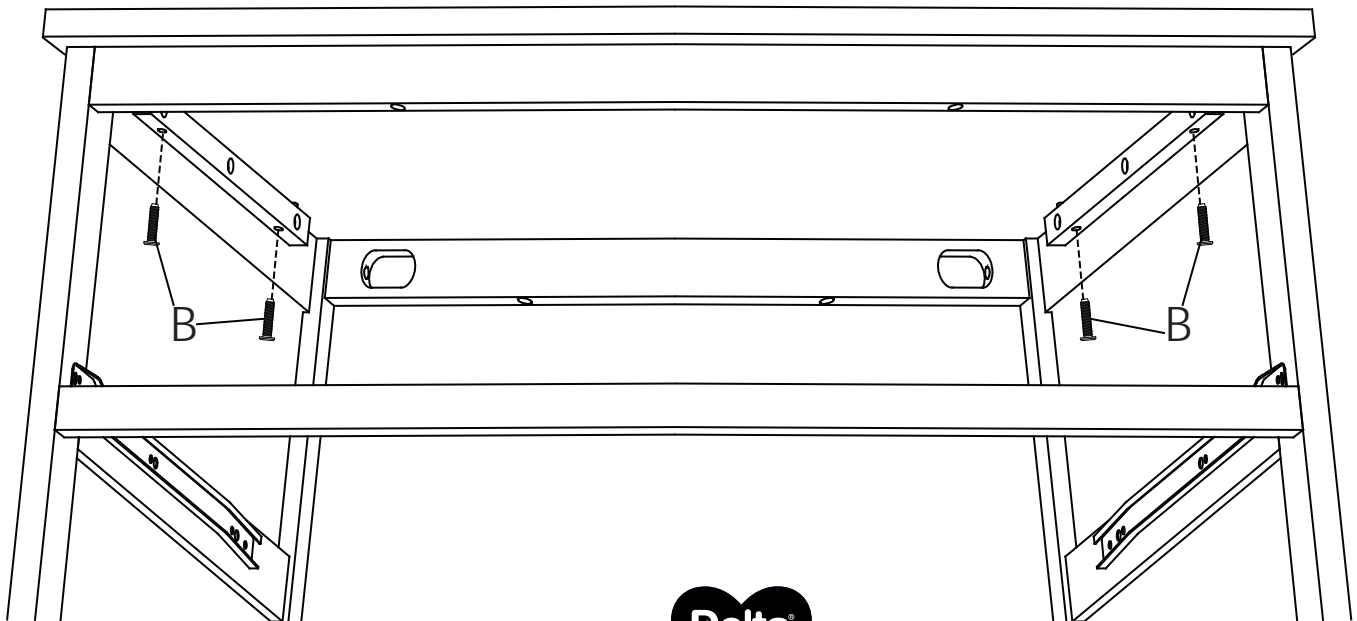
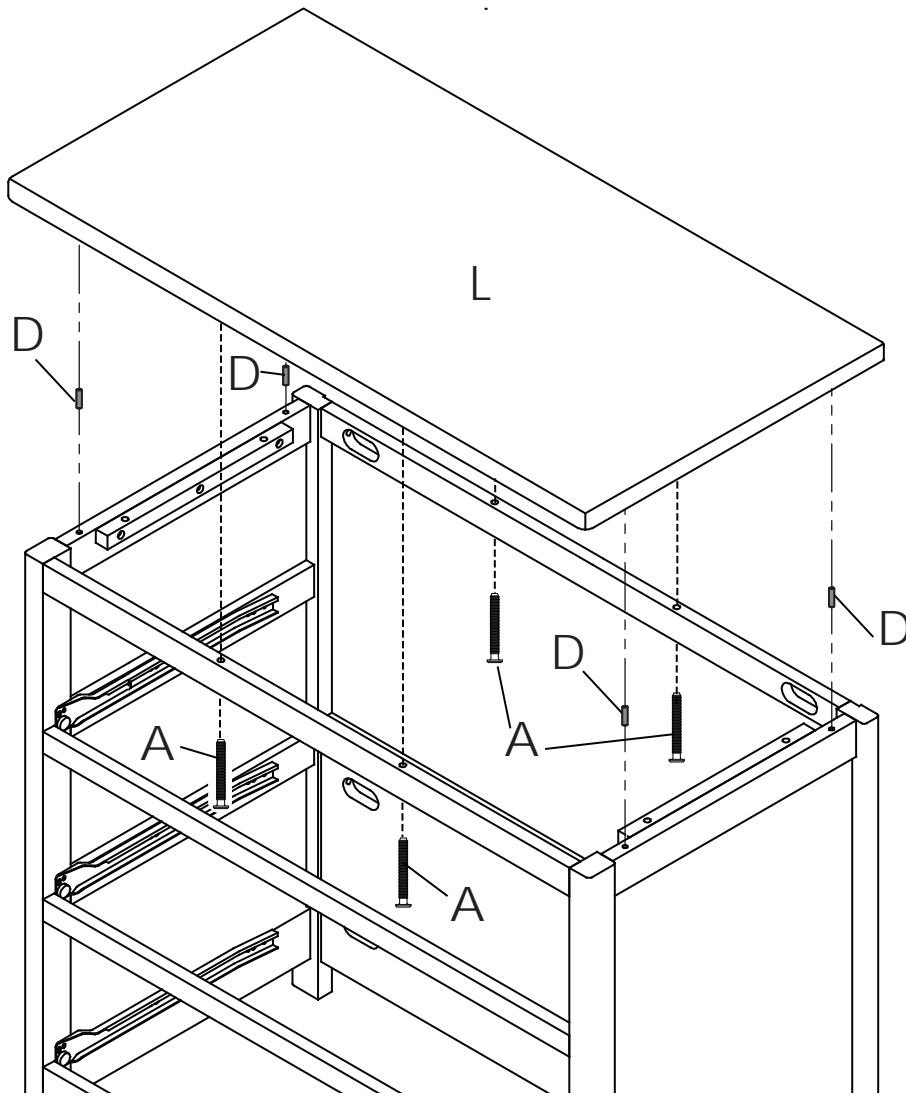



Step 4
Étape 4
Paso 4

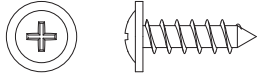

F. 16mm Back Panel Screw x16
Vis 16mm pour Panneau Arrière
Tornillo 16mm de Panel Trasero

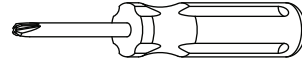

Phillips Screwdriver – Not included
Tournevis Phillips - non inclus
Destornillador Phillips – no incluido

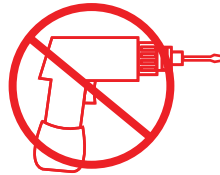

CAUTION: Do Not use a power screwdriver they can cause screws to break or strip.
ATTENTION: Ne Pas utiliser un tournevis électrique car les vis peuvent casser ou perdre leurs filets.
ATENCIÓN: No use un destornillador eléctrico ya que puede causar que los tornillos se rompan o rueden.

Attach Back Panel (Part U) using (16) Screws (Part F). Tighten with a Phillips Screwdriver.

Attachez les (1) Panneau Arrière (Partie U) en utilisant les (16) Vis (Partie F). Serrez avec un tournevis Phillips.

Fije (1) Panel Trasero (Parte U) con ayuda de (16) Tornillos (Parte F). Apriete con un destornillador Phillips.



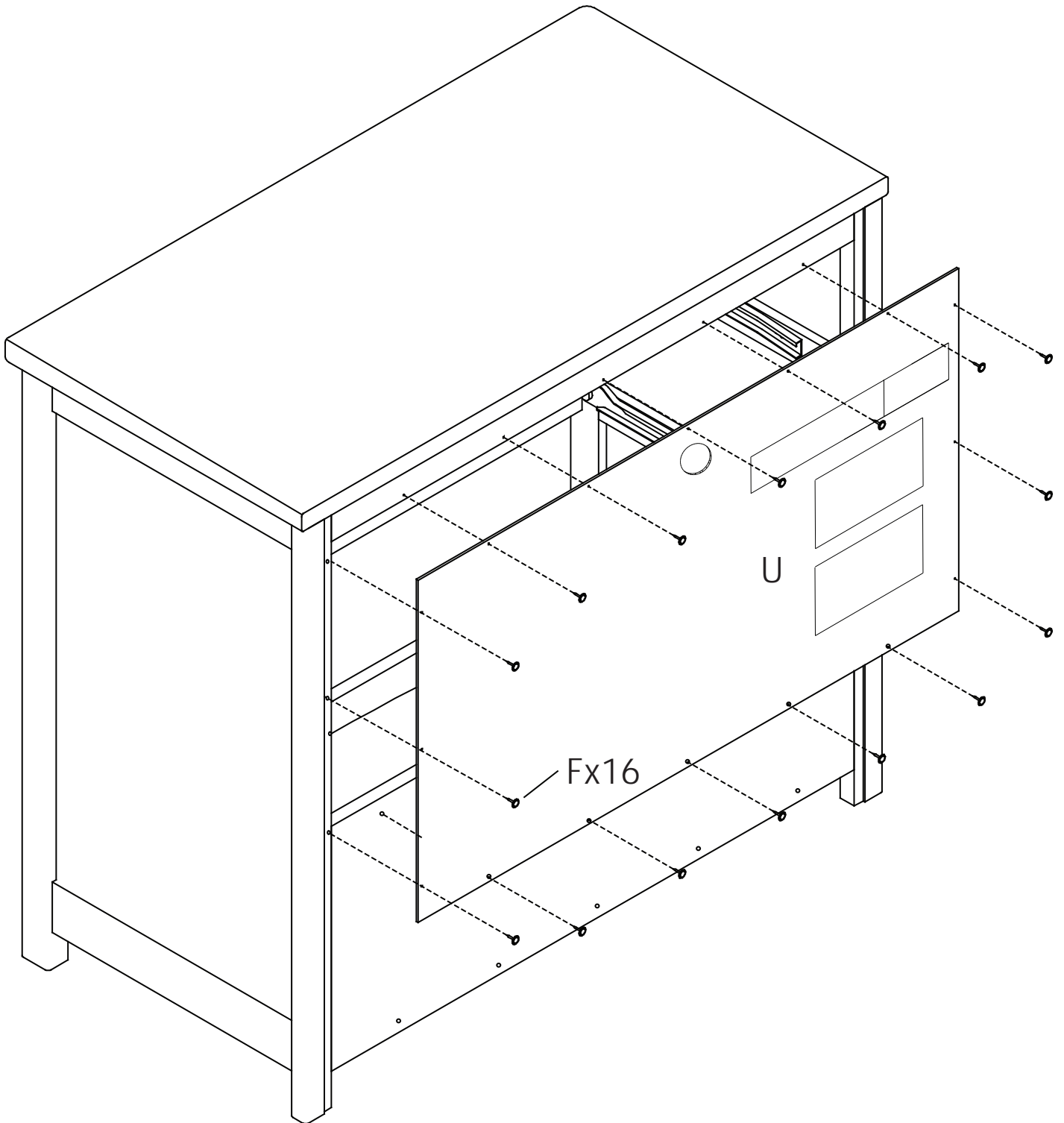

STEP #5

ÉTAPE N°5

PASO #5

Tipover Restraint

Dispositif de non-renversement

Protección contra volcamiento

▲ WARNING

Use of tip-over restraints may only reduce, but not eliminate, the risk of tip-over.

Do not attempt to screw into the wallboard only. You must screw into a wood wall stud or other wood structure such as securely attached baseboard. If your wall is not wood stud construction, see your local hardware store or home center for a wall anchor system that will hold a pull force of 50 LBS in your wall type. If you are unsure of how to locate the wood stud, or of what type of wall you have, contact a professional contractor.

▲ AVERTISSEMENT

L'utilisation de dispositif anti-renversement peut uniquement réduire les risques de renversement, mais ne les élimine pas totalement.

Ne tentez pas de le visser dans le panneau de revêtement uniquement. Vous devez visser dans un poteau mural en bois ou toute autre structure en bois telle qu'une plinthe solidement fixée. Si votre mur n'est pas construit de montants de bois, voyez votre quincaillerie locale ou centre de rénovation pour une ancre de mur pouvant supporter 50 livres dans votre type de mur. Si vous êtes incertain par rapport à comment localiser le montant ou à quel type de mur vous avez, contactez un entrepreneur professionnel.

▲ ADVERTENCIA

El uso de herramientas de contención de vuelcos tan solo puede reducir, pero no eliminar, el riesgo de vuelco.

No intente atornillar a paredes hechas únicamente de paneles. Debe atornillar en un pilar u otra estructura de madera similar, como un zócalo fijado de manera segura. Si su pared no tiene vigas de Madera, visite su ferretería o tienda del ramo más cercana para conseguir un sistema de anclaje que soporte una fuerza de tiraje de hasta 50 LBS (22,7 Kgs) para su tipo de muro. Si no está seguro sobre cómo encontrar la viga de madera o tiene dudas sobre el tipo de muro, contacte a un contratista profesional.

1) Choose BOTTOM or TOP attachment.

2) Locate the through holes in the back of the dresser.

3) Align the hole to be used with the wood wall stud (For Open Bottom Installation, use wood wall stud closest to center)

1) Choisissez une fixation SUPÉRIEURE ou INFÉRIEURE.

2) Repérez les trous percés au dos de la commode.

3) Alignez le trou à utiliser sur le poteau mural en bois (Pour une installation à fond ouvert, utilisez le poteau mural le plus près du milieu)

1) Seleccione el aditamento SUPERIOR o INFERIOR.

2) Ubique los orificios pasantes en la parte posterior del mueble.

3) Alinee el orificio que utilizará con el pilar de la pared (para una instalación con fondo abierto, utilice el pilar de madera más cercano al centro)

4) Make a pencil mark on the wall using the wood rail as a guide, pencil mark must be over wood wall stud. Then move the case away from the wall.

4) Faites une marque sur le mur à l'aide d'un crayon en vous servant du barre en bois comme guide, la marque au crayon doit être au-dessus du poteau mural en bois. Ensuite, déplacez la caisse afin de l'éloigner du mur.

4) Utilizando un lápiz, haga una marca en la pared utilizando el barra de madera como guía; la marca debe estar sobre el pilar de madera. Luego, aleje la carcasa de la pared.

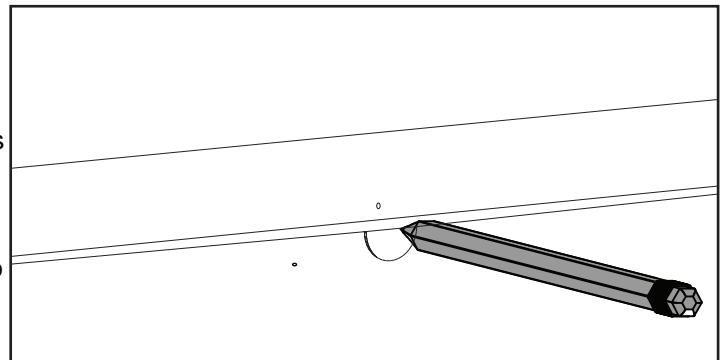

5) Drill Ø1/8" hole at Pencil Mark, in wood wall stud

5) Percez un trou de 1/8 po de diamètre à l'emplacement de la marque au crayon, dans le poteau mural en bois

5) Perfore un orificio de Ø1/8" en la marca del lápiz, sobre el pilar de madera

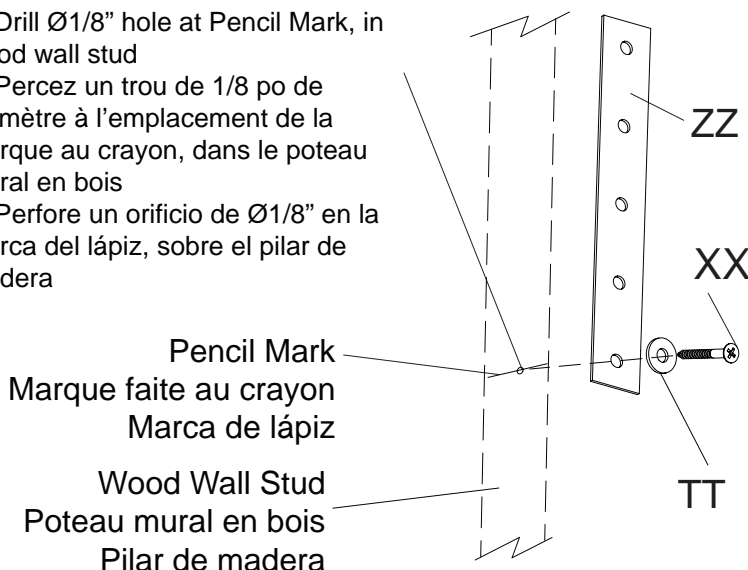

6) Attach the Tip-over restraint strap (ZZ) to the wall using (1) Long Screw (XX) and (1) washer (TT) as shown. The screw MUST be installed into a wood wall stud (See WARNINGS for additional information).

6) Fixez la sangle du dispositif de non-renversement (ZZ) au mur à l'aide de (1) vis longue (XX) et de (1) rondelle (TT) tel qu'illustré. La vis DOIT être serrée dans un poteau mural en bois (Pour de plus amples informations, veuillez vous référer aux AVERTISSEMENTS).

6) Fije la correa de retención contra volcamiento (ZZ) a la pared utilizando (1) tornillo largo (XX) y (1) arandela (TT), como se indica. El tornillo DEBE instalarse en un pilar de madera (para obtener más información consulte las ADVERTENCIAS).

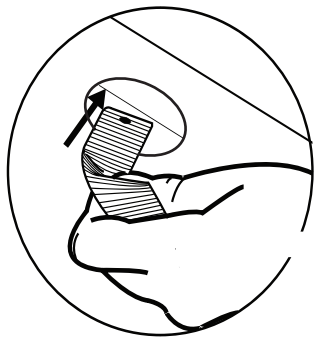

NOTE: Be sure to attach any accessory items to case before completing this step.
 7) Feed the Tipover Restarint through the hole as you place the dresser in it's final position.
 REMARQUE : Veuillez à fixer tous accessoires sur la caisse avant de l'exécution de cette étape.
 7) Faites entrer le dispositif de non-renversement à travers le trou lorsque vous placez la commode dans s position finale.
 NOTA: Asegúrese de fijar todos los accesorios a la carcasa antes de completar este paso.
 7) Pase el elemento de retención a través del orificio, a medida que posiciona el mueble en su posición final.

8) Pull the Tip-over restraint through the hole and fasten it securely to the case using (1) 15mm screw (YY) and (1) washer (TT).
 8) Tirez le dispositif de non-renversement à travers le trou, puis fixez-le solidement sur la caisse à l'aide de (1) vis de 15 mm (YY) et de (1) rondelle (TT).
 8) Pase el elemento de retención a través del orificio y fíjelo con seguridad a la carcasa utilizando (1) tornillo de 15 mm (YY) y (1) arandela (TT).

Attach to Top
 Fixez-le à la partie supérieure
 Fijar a la parte superior

Attach to Bottom
 Fixez-le à la partir inférieure
 Fijar al fondo

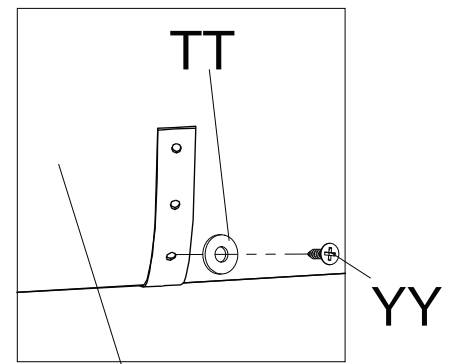
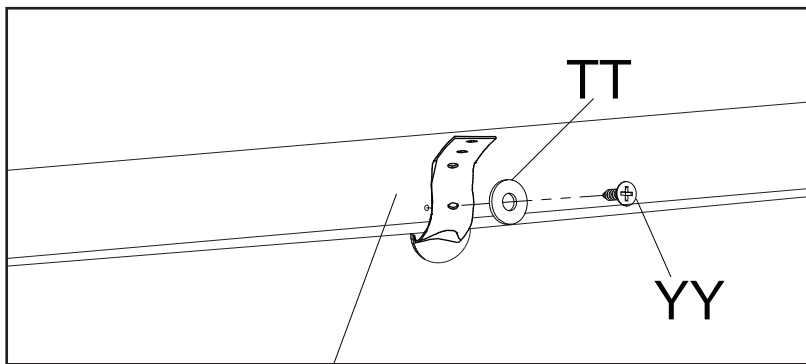

Top Back Rail
 Barre Arrière Supérieur
 Barra Trasero Superior

Bottom Back Rail
 Barre Arrière Inférieur
 BarraTraseroInferior

9) Pull case AWAY from wall until Restraint is SNUG.
 9) Tirez la caisse afin de L'ÉLOIGNER du mur jusqu'à ce que le dispositif de non-renversement soit BIEN AJUSTÉ
 9) Jale la carcasa ALEJÁNDOLA de la pared hasta que la retención esté TENSA.

10) Ensure restraint is not loose.
 10) Assurez-vous que le dispositif de non-renversement n'est pas desserré.
 10) Asegúrese de que la retención no esté suelta.

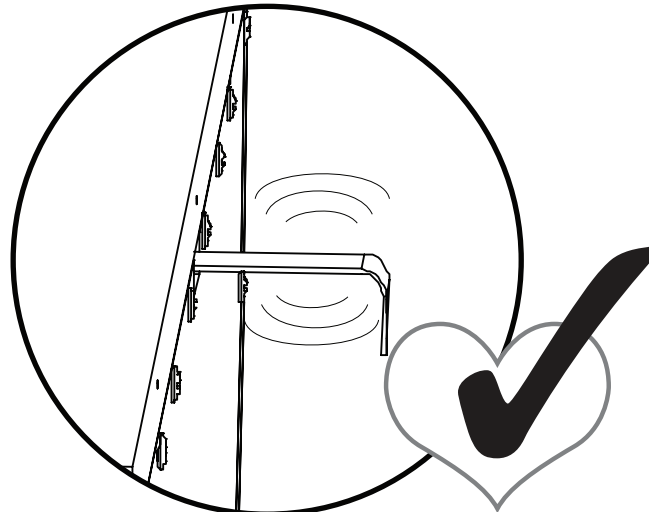
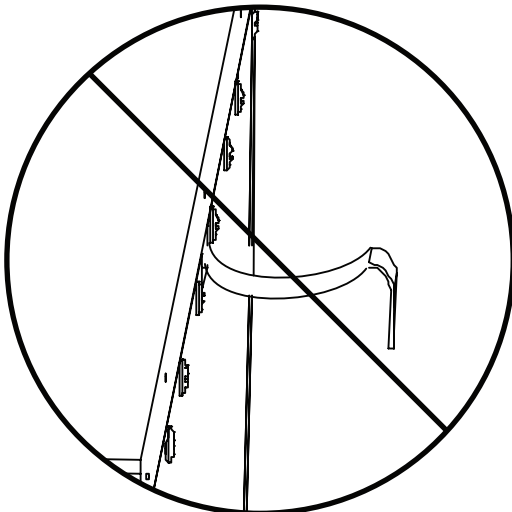



Step 6
Étape 6
Paso 6

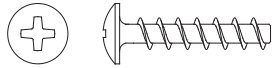

H. 20mm Screw x12
Vis 20mm
Tornillo 20mm

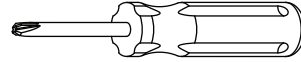

Phillips Screwdriver – Not included
Tournevis Phillips - non inclus
Destornillidor Phillips – no incluido

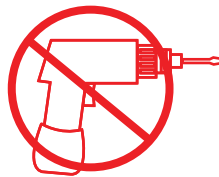

CAUTION: Do Not use a power screwdriver they can cause screws to break or strip.
ATTENTION: Ne Pas utiliser un tournevis électrique car les vis peuvent casser ou perdre leurs filets.
ATENCIÓN: No use un destornillador eléctrico ya que puede causar que los tornillos se rompan o rueden.

Slide Drawer Bottom (Part FF) into the grooves. Attach the Right and Left Drawer Sides (Part DD and EE) to the Drawer Front (Part AA or BB) with (4) 20mm Screws (Part H). Note: Grooves in Bottom must align. Tighten With Phillips Screwdriver. Repeat this step until 3 drawers are complete.

Glisser le fond du tiroir (Pièce FF) dans les rainures. Fixer les Côté Gauche et Côté Droit du Tiroir (Pièce DD et EE) à l'avant du tiroir (Pièce AA ou BB) à l'aide de (4) vis 20mm (Pièce H). Remarque: Les rainures inférieures doivent être alignées. Serrer avec un tournevis Phillips. Répéter cette étape jusqu'à ce que les 3 tiroirs soient montés.

Deslice la Fondo de la gaveta (Pieza FF) hacia las ranuras. Fije los Lados Izquierdo y Derecho dela Gaveta (Pieza DD y EE) a la parte frontal de la gaveta (Pieza AA o BB) utilizando (4) tornillos 20mm (Pieza H). Nota: Las ranuras al inferior deben alinearse. Apriete utilizando un destornillador Phillips. Repitaestepaso hasta haber completadolos 3 gavetas .



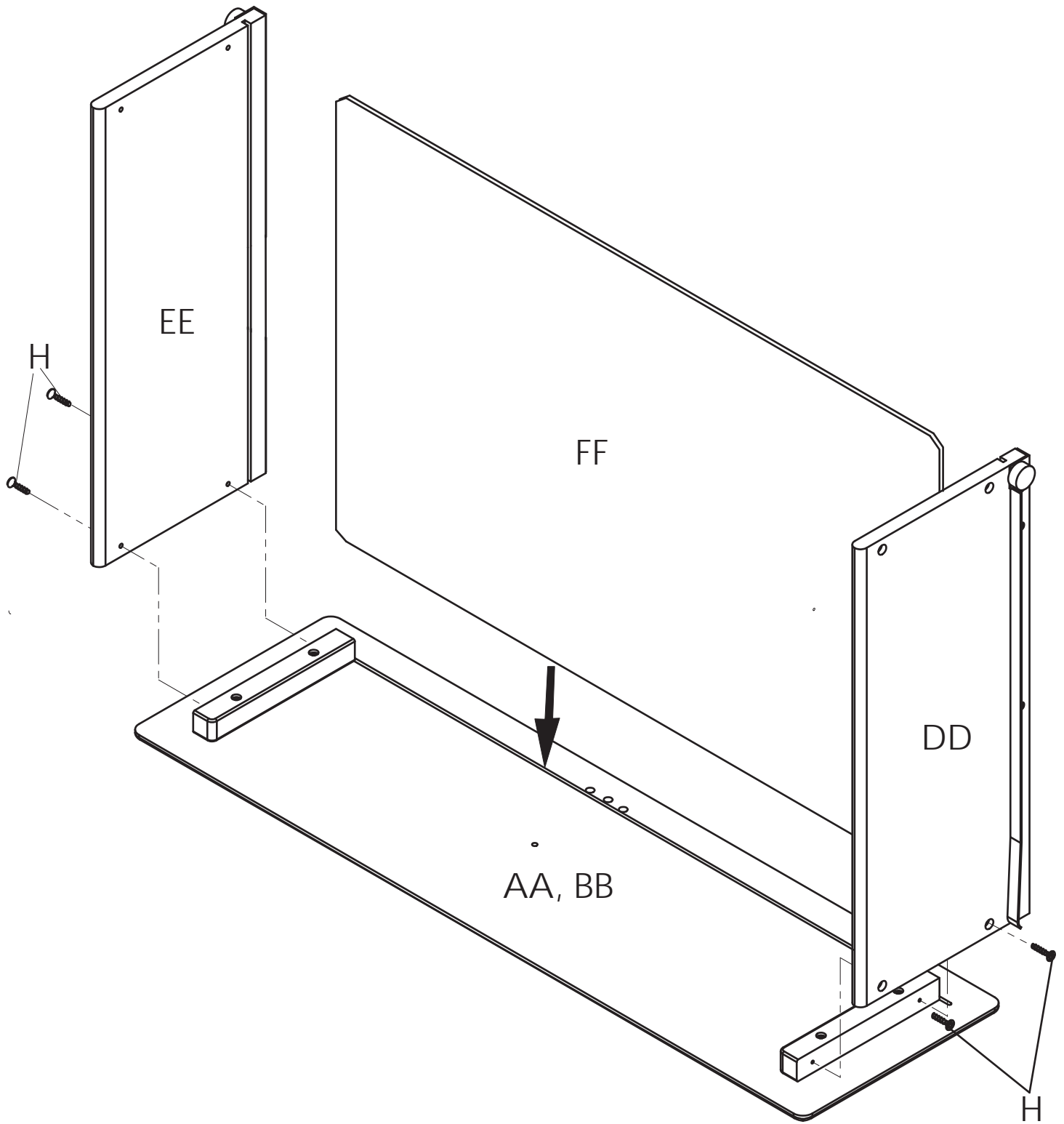

x3





Step 7
Étape 7
Paso 7

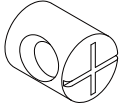

E. Plastic Barrel Nut x15
Écrou à portée cylindrique
en plastique
Tuerca cilíndrica plástica

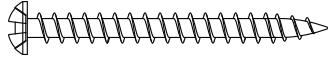

P. 40mm SCREW x15
Vis 40mm
Tornillo 40mm

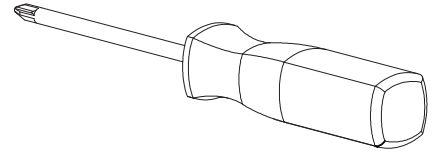

Phillips Screwdriver – Not included
Tournevis Phillips - non inclus
Destornillador Phillips – no incluido

CAUTION: Do Not use a power screwdriver they can cause screws to break or strip.

ATTENTION: Ne Pas utiliser un tournevis électrique car les vis peuvent casser ou perdre leurs filets.

ATENCIÓN: No use un destornillador eléctrico ya que puede causar que los tornillos se rompan o rueden.

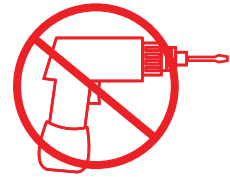

Install the Drawer Support (Part GG) and Drawer Back (Part CC), using (5) 40mm Screws (Part P) and (5) Plastic Barrel Nuts (Part E). Note: Grooves In Bottom Must Align. Tighten With Phillips Screwdriver. Repeat this step until 3 drawers are complete.

Installer le support du tiroir (Pièce GG) et l'arrière du tiroir (Pièce CC), à l'aide de (5) vis 40mm (Pièce P) et de (5) Écrous à portée cylindriques en plastique (Pièce E).
Remarque: Les rainures inférieures doivent être alignées. Serrer avec un tournevis Phillips. Répéter cette étape jusqu'à ce que les 3 tiroirs soient montés.

Instale el soporte de gaveta (Pieza GG) y Trasera de la gaveta (Pieza CC) utilizando (5) tornillos de 40 mm (Pieza P) y (5) tuercas cilíndricas plásticas (Pieza E). Nota: Las ranuras al inferior deben alinearse. Apriete utilizando un destornillador Phillips. Repita este paso hasta haber completado las 3 gavetas.

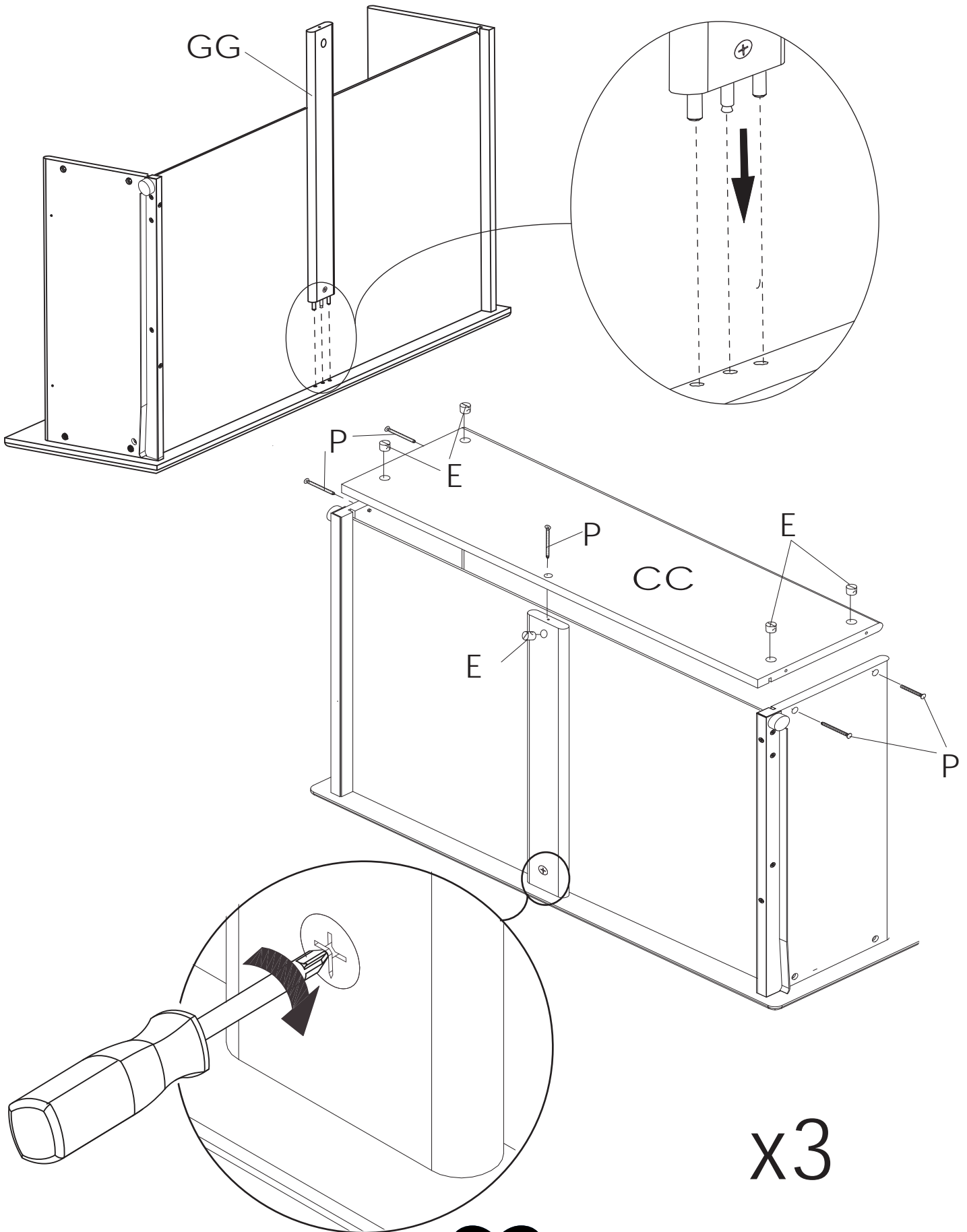



Step 8
Étape 8
Paso 8

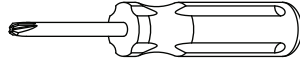

Phillips Screwdriver – Not included
Tournevis Phillips - non inclus
Destornillidor Phillips – no incluido

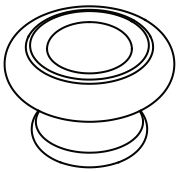

G1. Knob
Bouton
Perilla



G2. 25mm Knob Screw
Vis de Bouton
Tornillo para Perilla

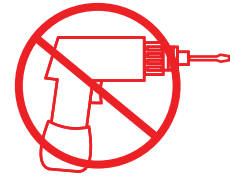

CAUTION: Do Not use a power screwdriver they can cause screws to break or strip.
ATTENTION: Ne Pas utiliser un tournevis électrique car les vis peuvent casser ou perdre leurs filets.
ATENCIÓN: No use un destornillador eléctrico ya que puede causar que los tornillos se rompan o rueden.

Attach (3) Knobs (Part G1) with (3) Knob Screw (Part G2) to the top drawer. Attach (2) Knobs (Part G1) with (2) Knob Screws (Part G2) to the Middle drawer and bottom drawer. Tighten with a Phillips Screwdriver.

Fixer (3) Boutons (Pièce G1) à l'aide d'(3) Vis de Bouton (Pièce G2) au tiroir supérieur. Fixer (2) Boutons (Pièce G1) à l'aide d'(2) Vis de Bouton (Pièce G2) au tiroir Central et au tiroir inférieur Serrer avec un tournevis Phillips.

Fije (3) Perillas (Pieza G1) utilizando (3) Tornillo para Perilla (Pieza G2) a la gaveta superior. Fije (2) Perillas (Pieza G1) utilizando (2) Tornillos para perilla (Pieza G2) a la gaveta central y a la gaveta inferior. Apriete utilizando un destornillador Phillips.



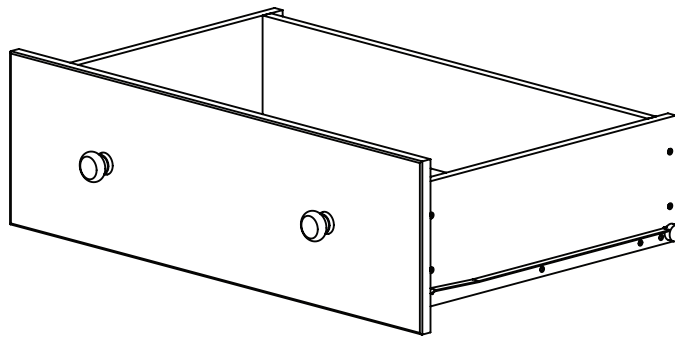
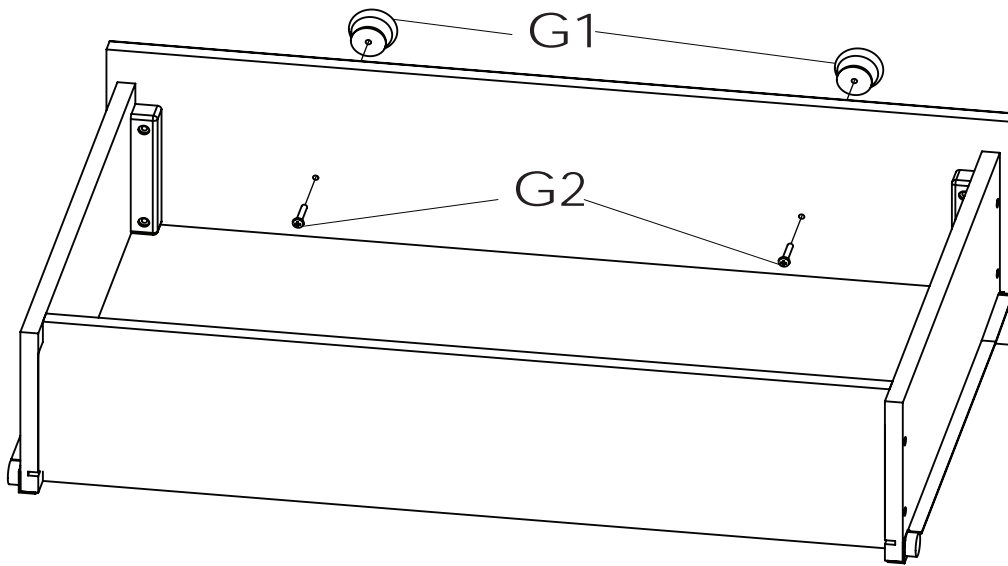



Step 9
Étape 9
Paso 9

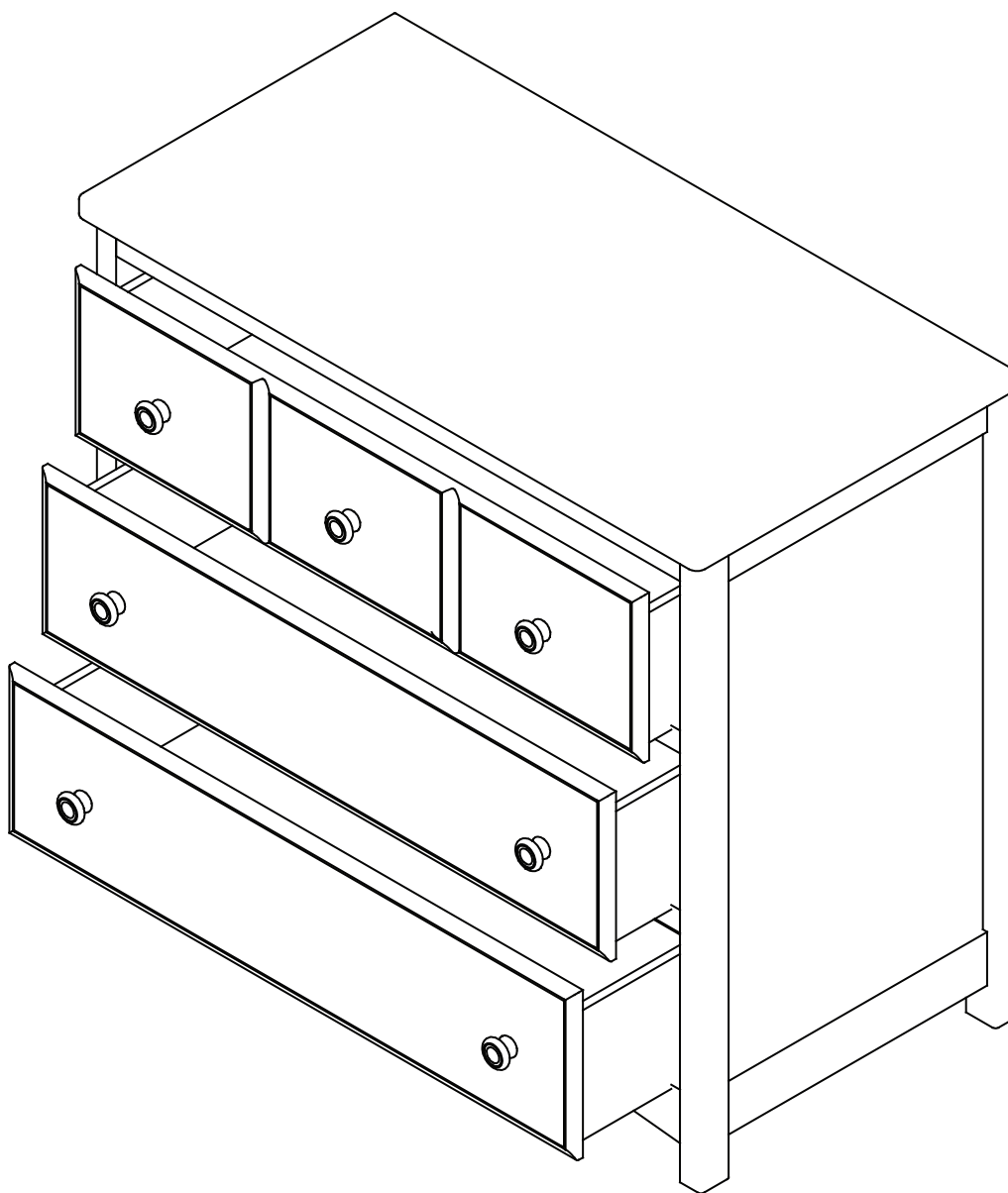

Install the drawers as shown. Changing the position of the drawer may improve the fit and/or appearance.

Installez les tiroirs comme montrés. Changer la position du tiroir peut améliorer l'adaptation et/ou apparence.

Instale las gavetas como se muestra. Puede mejorar la apariencia o el ajuste cambiando la posición de la gaveta.



Consumer Experience Center

www.DeltaChildren.com

Delta Children's Products Corp

114 West 26th Street

New York, NY 10001

(646) 435-8727

wcs@DeltaChildren.com

Limited Warranty: This Delta product is warranted to be free from defects for a period of 90 days from the date of purchase under normal use. This warranty extends only to the original retail purchaser and is valid only when supplied with proof of purchase, or if received as a gift, when the registration is on file with Delta. This limited warranty **does not cover** the following:

- Products purchased as floor models or samples.
- Items purchased on an "as-is" basis, as a second hand product, or as a resale product.
- Items purchased at a Final sale, a "Going out of Business" sale or a Liquidation sale.

Garantie Limitée: Ce produit Delta est garanti libre de défauts pour une période de 90 jours à partir de son achat et dans des conditions normales d'utilisation. Cette garantie se donne uniquement à l'acheteur d'origine et elle est valable seulement sur présentation d'une preuve d'achat, ou si le produit a été reçu en tant que cadeau alors il doit avoir été enregistré chez Delta. Cette garantie limitée du fabricant **ne couvre pas** les cas suivants :

- Produits achetés comme modèles d'exposition ou échantillons.
- Articles achetés comme « en l'état », produits d'occasion ou revente des produits.
- Articles achetés en « vente finale », ventes dans « magasins en faillite » ou ventes par liquidation.

Garantía Limitada: Este producto Delta está garantizado de estar libre de defectos por un período de 90 días a partir de su adquisición, bajo uso normal. Esta garantía se otorga únicamente al comprador original y es válida solamente cuando se proporciona una prueba de compra, o si el producto fue recibido como un regalo, debe haber sido registrado con Delta. Esta garantía limitada del fabricante **no cubre** lo siguiente:

- Productos comprados como exhibiciones de la tienda o muestras.
- Artículos comprados como "tal como está", productos de segunda mano o reventa de los productos.
- Artículos comprados como "venta final", "ventas de tiendas que están quebrando" o ventas por liquidación.

To register your product for important safety alerts and updates to your product please visit **www.deltachildren.com**

Pour enregistrer votre produit pour avoir les alertes de sécurité et les mises à jour de votre produit veuillez visiter **www.DeltaChildren.com**

Para registrar su producto para alertas importantes de seguridad y estar al tanto sobre novedades de su producto por favor visite **www.DeltaChildren.com** y seleccione Product Registration.

To report a problem, please log on to **www.deltachildren.com** and click the Consumer Care Tab, or contact us by phone at (646) 435-8727

Pour signaler un problème, veuillez vous connecter à **www.DeltaChildren.com** et cliquez sur la touche Consumer Care, ou contactez nous par téléphone au (646) 435-8727

Para reportar cualquier problema, por favor entre a **www.DeltaChildren.com** y de clicen Servicio al cliente o contáctenos por teléfono al (646) 435-8727

Date of Purchase: _____ (you should also keep your receipt)

Date d'Achat: _____ (vous devriez aussi garder votre facture d'achat)

Fecha de Compra: _____ (debe además mantener su recibo)



SAFETY LEADERS

Visit Deltachildren.Com/Pages/Leaders-In-Safety for more information

SAFE MATERIALS

Safe products start with safe materials. We test all of our products to create the safest and healthiest environment for your baby.

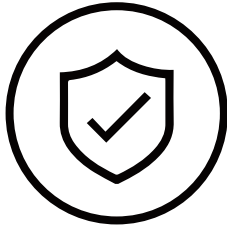

PRODUCTS YOU CAN TRUST

We have 8 cutting edge safety labs around the world where we test our products above and beyond the industry standards. All of our dressers are engineered to meet or exceed ASTM Furniture Safety Standards.



WE GO ABOVE & BEYOND

To protect your children, Delta Children dressers are tested to meet the requirements of the industry tip over test set forth by ASTM. For additional security, we strongly recommend that all dressers in your home be anchored; all Delta Children dressers include a wall anchor.





LEADERS EN MATIÈRE DE SÉCURITÉ

Visitez Deltachildren.Com/Pages/Leaders-In-Safety pour plus d'informations

MATÉRIAUX SURS

Les produits surs sont faits à partir de matériaux surs. Nous testons tous nos produits pour créer l'environnement le plus sûr et plus sain pour votre bébé.



DES PRODUITS FIABLES

Nous possédons 8 laboratoires de pointe en matière de sécurité où nous testons nos produits au delà des standards industriels. Toutes nos commodes sont conçues pour être aux normes selon les standards de sureté des meubles ASTM et même les dépasser.



NOUS ALLONS AU-DELÀ

Pour protéger vos enfants, les commodes de Delta Children sont testées pour satisfaire les exigences du test industriel de basculement indiqué par ASTM. Pour une sécurité additionnelle, nous recommandons fortement l'ancrage de toutes les commodes dans votre maison; toutes les commodes de Delta Children incluent une fixation pour le mur.





LÍDERES EN LA SEGURIDAD

Visite Deltachildren.Com/Pages/Leaders-In-Safety para más información

MATERIALES SEGUROS

Los productos seguros se hacen con materiales seguros. Ponemos a prueba todos nuestros productos para crear el ambiente más seguro y saludable para su bebé.



PRODUCTOS CONFIABLES

Tenemos 8 laboratorios de seguridad de alta tecnología donde probamos nuestros productos mas allá de los estándares de la industria. Todos nuestros tocadores están diseñados para cumplir o exceder los estándares de seguridad ASTM de muebles.



ESTAMOS POR ENCIMA Y MÁS ALLÁ

Para proteger a sus niños, los tocadores de Delta Children son sometidos a pruebas para que cumplan los requisitos ASTM establecidos de la industria en cuanto a volcamientos se refiere.

Para seguridad adicional, recomendamos enfáticamente que todos los tocadores de su casa estén fijos: todos los tocadores de Delta Children incluyen un anclaje de pared.





POURQUOI CHOISIR POR QUÉ ELEGIR A DELTA CHILDREN?

Visitez Deltachildren.Com/Pages/Our-Story pour plus d'information

Visita Deltachildren.Com/Pages/Our-Story para más información

<p>DELTA EN TÊTE Un enfant sur deux aux U.S.A. dort dans nos produits</p>	<p>DELTA DONNE 10% de nos revenus sont dédiés à l'amélioration de la vie des enfants</p>	<p>DELTA PREND SOIN Nous testons la conformité au-delà des standards de sécurité de l'industrie</p>	<p>DELTA EST DÉVOUÉ familiale a été présente pour votre famille depuis 1968</p>	<p>DELTA GRANDIT AVEC VOUS Nous avons des produits pour chaque âge et chaque étape</p>	<p>Plus De 50 Ans De Sécurité, Design & Innovation</p>
<p>DELTA LIDERA 1 de cada 2 niños en los EE.UU duerme en nuestros productos</p>	<p>DELTA DONA 10% de nuestros ingresos está destinado a mejorar la vida de los niños</p>	<p>A DELTA LE IMPORTA Hacemos pruebas por encima de los estándares de seguridad de la industria</p>	<p>DELTA ESTÁ DEDICADA Nuestra empresa familiar ha estado siempre presente para su familia desde 1968</p>	<p>DELTA CRECE CON USTEDES Tenemos productos para cada edad y etapa</p>	<p>Más De 50 Años De Seguridad, Estilo E Innovación</p>

Bienvenue dans la
FAMILLE DELTA
Voici Notre Cadeau Pour Vous

Bienvenido a la
FAMILIA DELTA
Aquí Está Nuestro Regalo Para Usted

10% OFF

Votre Prochain Achat Chez
Su Próxima Compra En
DeltaChildren.com

**UTILISEZ LE CODE:
UTILICE EL CÓDIGO:
DELTA10**

*Des exclusions s'appliquent
*Sujet à changement *Exclusions Apply
*Subject to Change

DES PRODUITS POUR CHAQUE ÂGE ET CHAQUE ÉTAPE PRODUCTOS PARA CADA EDAD Y ETAPA



NOTRE FAMILLE DE MARQUES SUPÉRIEURES / NUESTRA FAMILIA DE LAS MEJORES MARCAS



PLUS DE 50 ANS DE SÉCURITÉ, DESIGN & INNOVATION / MAS DE 50 ANOS DE SEGURIDAD, ESTILO E INNOVACIÓN





WHY CHOOSE DELTA CHILDREN?

Visit Deltachildren.Com/Pages/Our-Story for more information

<p>DELTA LEADS 1 Out Of 2 Children In The U.S. Sleep In Our Products</p>	<p>DELTA GIVES 10% Of Our Profits Go Toward Improving The Lives Of Children</p>	<p>DELTA CARES We Test Above & Beyond Industry Safety Standards</p>	<p>DELTA IS DEDICATED Our Family-Run Company Has Been There For Your Family Since 1968</p>	<p>DELTA GROWS WITH YOU We Have Products For Every Age And Stage</p>	<p>Over 50 Years Of Safety, Style & Innovation</p>
---	--	--	---	---	---

Welcome to the
DELTA FAMILY
Here's a Gift From Us To You

10% OFF

Your Next Purchase From
DeltaChildren.com

USE CODE:
DELTA10

*Exclusions Apply
*Subject to Change

PRODUCTS FOR EVERY AGE AND STAGE

 CRIBS LITS POUR BÉBÉ CUNAS	 STROLLERS EQUIPEMENT POUR BÉBÉ COSAS PARA BEBÉ	 GLIDERS CHAISE SILLA	 BASSINETS COUFFINS MOISÉS	 MATTRESSES MATELAS COLCHÓN
 BABY GEAR POUSSETTES CARRIOLAS	 TODDLER BEDS LITS POUR ENFANT CAMA PARA NIÑO	 PLAYROOM FURNITURE SALLE DE JEUX CUARTO DE JUGAR	 TWIN BEDS LITS UNE PLACE CAMA SENCILLA	 BINS & ORGANIZERS PANIERES CONTENEDORES
 DRESSERS COMMODES TOCADORES				

OUR FAMILY OF TOP BRANDS



OVER 50 YEARS OF SAFETY, STYLE, AND INNOVATION

