

DELTA♥CHILDREN™ Dresser With Changing Top

Read all instructions before assembly and use.

KEEP INSTRUCTIONS FOR FUTURE USE.



To Make Assembly Even Easier Watch Video Here!

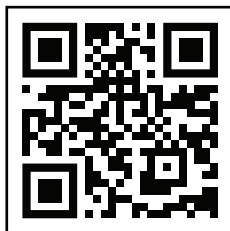

For Questions or to Contact Us:

DeltaChildren.com/Help

If unable to access website, please email wcs@DeltaChildren.com

Expect longer response times via email.

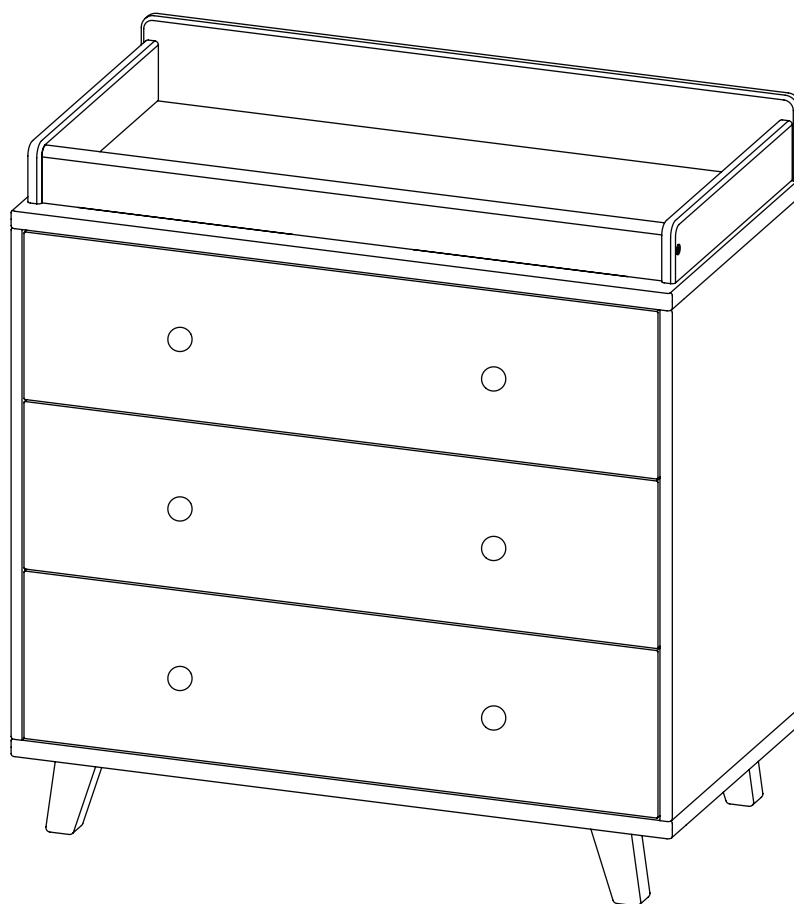

sample tested to meet U.S. Federal, ASTM and other safety requirements

Style #: _____

 Lot: _____

REV Date: _____

Before contacting Delta Consumer Experience Center please ensure this information matches the information found on the label on the Back Panel.



ADULT ASSEMBLY REQUIRED

Due to the presence of small parts during assembly, keep out of reach of children until assembly is complete.

This product is not intended for institutional or commercial use.

DELTA♥CHILDREN™ **Cómoda con el cambiador**

Lea todas las instrucciones antes de ensamblar y usar.

MANTENGA LAS INSTRUCCIONES PARA SU USO FUTURO.



Para facilitar más aun el ensamblaje ver el video aquí

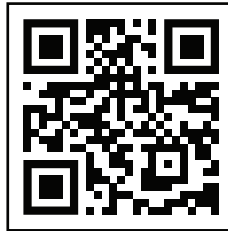

Para preguntar o para contactarnos :

DeltaChildren.com/Help
Si no puede acceder el sitio web, por favor envíenos un email a wcs@DeltaChildren.com
El tiempo de espera para respuestas será más largo por email.

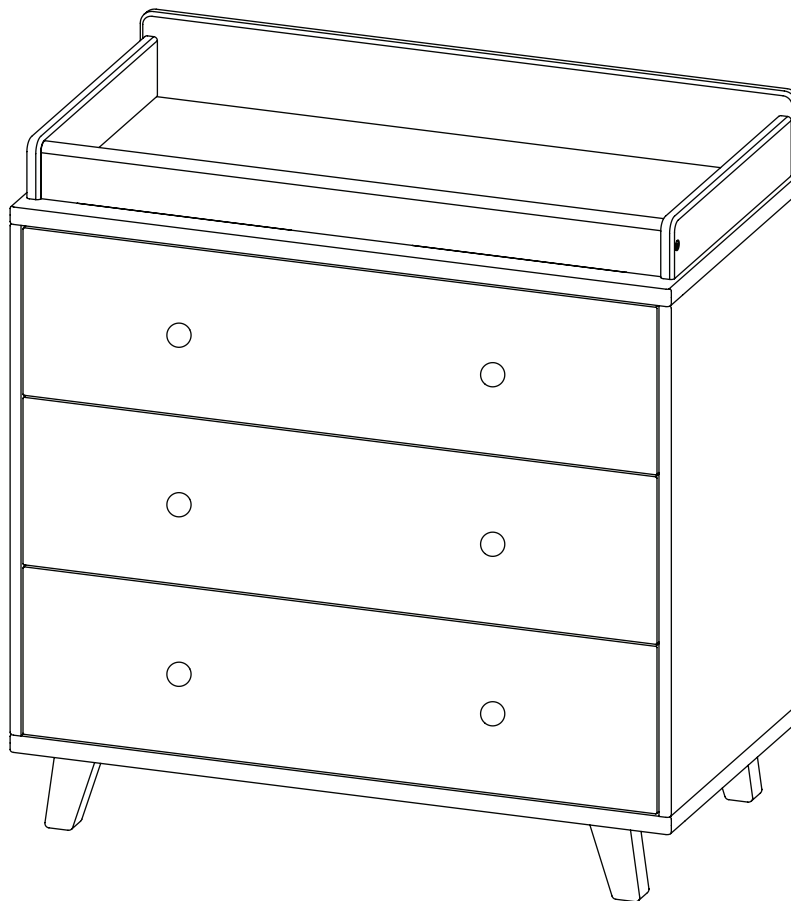

sample tested to meet U.S. Federal, ASTM and other safety requirements

Antes de contactar el Centro de Experiencia del Consumidor de Delta por favor asegúrese de que la información de la primera página coincida con la información que se encuentra en la etiqueta ubicada en el panel trasero.



DEBE SER ENSAMBLADO POR UN ADULTO

Debido a la presencia de piezas pequeñas durante el ensamblaje, mantenga fuera del alcance de los niños hasta que complete el ensamblaje.

Este producto no está hecho para uso institucional o comercial.

⚠️ WARNING

FALL HAZARD - To prevent death or serious injury, always keep child within arm's reach.

Read all instructions before use of the Changing Top .

KEEP THESE INSTRUCTIONS IN A SAFE PLACE FOR FUTURE USE.

Inspect the changing table periodically. Do not use the Changing Top if it is damaged or broken. Contact Delta Children with any questions.

Tighten all loose screws and bolts before each use.

The maximum recommended weight of the child is 30lbs for the changing table.

Always secure the Changing Top to the changing surface using the screws provided. See Instructions. Secure the Changing Top only to Delta Children item 68013.

The changing pad used should be 34" x 16" with a maximum thickness of 1".

⚠️ ADVERTENCIA

PELIGRO DE CAIDAS - Para prevenir la muerte o lesiones graves, mantenga al niño al alcance de sus manos. Lea todas las instrucciones antes de usar el cambiador.

COLOQUE ESTAS INSTRUCCIONES EN UN LUGAR SEGURO PARA SU USO FUTURO.

Inspeccione este cambiador periódicamente. No use el cambiador si está dañado o roto.

Póngase en contacto con Delta Children para formular preguntas.

Apriete los tornillos y pernos flojos antes de cada uso.

El paso máximo recomendado 30 libras (13.6 g).

Coloque siempre el cambiador a la superficie cambiando con los tornillos suministrados. Lea las Instrucciones. Asegure el kit de vestido sólo al producto Delta Children 68013.

La almohadilla usada debe ser 34" x 16" pulgadas con un grosor máximo de 1 pulgada.

BABY SAFE SLEEP TIPS

Visit Deltachildren.Com/Pages/Crib-Safety-Tips for more information



Read all warnings and follow all instructions.



DO NOT place any items in the crib.



The safest place for your baby to sleep is in a JPMA Certified crib.



Pillows and blankets have caused infants to suffocate, **NEVER** use in a crib.



Your baby should sleep on a firm mattress.



NEVER place the crib near a window or any wall hangings.



Adult beds are not safe for babies: **NEVER** co-sleep.



Missing or broken parts, any questions?
www.DeltaChildren.com/Help



AAP RECOMMENDS:

Always lay your baby on its back to sleep.

Consult your doctor.

FURNITURE SAFETY TIPS

Visit Deltachildren.Com/Pages/Leaders-In-Safety for more information

SERIOUS OR FATAL CRUSHING INJURIES
CAN OCCUR FROM FURNITURE TIP-OVER.



Read all warnings and follow all instructions.

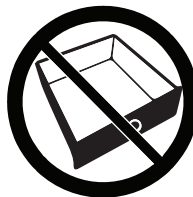

NEVER open more than one drawer at a time.



ALWAYS use provided tipover restraints.



DO NOT leave drawers open when not in use.



DO NOT set TV's or other heavy objects on the top of bedroom or nursery furniture.



NEVER allow children to climb or hang on drawers, doors, or shelves.



Place heaviest items in the lowest drawers.



Missing or broken parts, any questions?
www.DeltaChildren.com/Help

CONSEJOS PARA UN SUEÑO SEGURO PARA LOS BEBÉS

Visite Deltachildren.Com/Pages/Crib-Safety-Tips para obtener más información



Lea todas las advertencias y siga todas las instrucciones.



NO coloque artículos en la cuna.



El lugar más seguro para que su bebé duerma es una cuna con certificación JPMA.



Las almohadas y frazadas han provocado asfixia en menores; por lo tanto, **JAMÁS** se deben utilizar en una cuna.

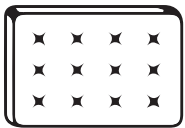

Su bebé debe dormir sobre un colchón firme.



JAMÁS coloque la cuna cerca de una ventana o elementos colgados en las paredes.



Las camas para adultos no son seguras para los bebés: **JAMÁS** duerma con ellos.



¿Le faltan piezas o vienen rotas?
www.DeltaChildren.com/Help



APP RECOMIENDA:

Haga que su bebé duerma siempre boca arriba.

Consulte a su médico.

CONSEJOS DE SEGURIDAD SOBRE MUEBLES

Visite Deltachildren.Com/Pages/Leaders-In-Safety para obtener más información

PUEDEN PRODUCIRSE LESIONES GRAVES O MORTALES
POR APLASTAMIENTO AL VOLCARSE MUEBLES.



Lea todas las advertencias y siga todas las instrucciones.

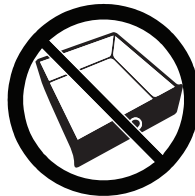

NUNCA abra más de un cajón al mismo tiempo.



Utilice **SIEMPRE** las retenciones contra volcamiento incluidas



NO DEJE cajones abiertos si no los está utilizando.



NO posicione televisores u otros objetos pesados sobre la cama o muebles para infantes.



NUNCA permita que los niños trepen sobre cajones, puertas o baldas de estantería ni que se cuelguen de ellos.



Coloque los artículos de mayor peso en los cajones inferiores.



¿Le faltan piezas o vienen rotas?
www.DeltaChildren.com/Help

SAVE BIG WITH DELTA CHILDREN

Visit **Deltachildren.com** To Start Shopping

Welcome to the
DELTA FAMILY
Here's a Gift From Us To You

10% OFF

Your Next Purchase From
DeltaChildren.com

USE CODE:
DELTA10

*Exclusions Apply
*Subject to Change

REVIEW TO WIN \$2500

RULES TO ENTER



"We LOVE, LOVE, LOVE this crib"

My husband was impressed with the directions and organization of the hardware package. He easily assembled this crib in an hour without any help. It's very sturdy and we like that it has adjustable levels for the mattress height. To top it all off, it's so incredibly darling!!!

- 1** **WRITE A REVIEW** for this product on the store's website from where it was purchased
- 2** **TAKE A SCREENSHOT** of your review and upload it to www.DeltaChildren.com/Review
- 3** **IT'S THAT EASY!** Upon submission, you'll be instantly **ENTERED TO WIN \$2,500**

FOLLOW US FOR MORE CHANCES TO WIN

   
@deltachildren

SCAN HERE



For more
information &
to see all of
our products

AHORRE MUCHO CON DELTA CHILDREN

Visita **Deltachildren.com** Para Comenzar A Comprar

Bienvenido a la
FAMILIA DELTA

Aquí Está Nuestro Regalo
Para Usted

**10%
OFF**

Su Próxima Compra En
DeltaChildren.com

UTILICE EL CÓDIGO:
DELTA10

*Exclusions Apply
*Subject to Change

CALIFIQUE EL PRODUCTO PARA **GANAR \$2500**

REGLAS PARA PARTICIPAR



- 1 **CALIFIQUE EL PRODUCTO** en la página web de la tienda donde haya sido comprado
- 2 **HAGA UNA CAPTURA DE PANTALLA** de su calificación y cárguela a la pagina www.DeltaChildren.com/Review
- 3 **ES ASÍ DE FÁCIL!** En cuanto lo envíe ya estará instantáneamente **PARTICIPANDO PARA GANAR \$2.500**

SÍGANOS PARA TENER MAS CHANCES DE GANAR

@deltachildren

ESCANEE AQUÍ



Para más
información
y para ver todos
nuestros productos

⚠ WARNING

Children have died from furniture tipover. To reduce the risk of furniture tipover:

- ALWAYS install tipover restraint provided.
- NEVER put a TV on this product.
- NEVER allow children to stand, climb or hang on drawers, doors, or shelves.
- NEVER open more than one drawer at a time.
- Place heaviest items in the lowest drawers.

**NOTES ON ASSEMBLY:**

- During the assembly process whenever using screws or bolts, check each by placing the screw/bolt on the diagram of the item which is drawn actual size and design. Be sure to use the proper size and shape specified in the instructions.
- To assemble this unit you may be required to place the unit on it's side and face. It is strongly recommended that assembly is done on a soft, non-abrasive surface to avoid damaging the finish.

NOTES ON USE:

Keep children and others safe by following these simple rules:

- **Do not** allow any child to play on furniture
- **Do not** allow climbing on any piece of furniture.
- **Do not** allow hanging from any piece of furniture.
- Always monitor your child's activity when in the nursery.

NOTES ON CARE AND MAINTENANCE:

- **Do not** scratch or chip the finish.
- Inspect the product periodically, contact Delta Children's Products for replacement parts or questions.
- **Do not** store the product or any parts in extreme temperatures and conditions such as a hot attic or a damp, cold basement. These extremes can cause a loss of structural integrity.
- To preserve the luster of the high quality finish on your product, it is recommended to place a doily or felt pad under any items you place on the finish.
- Clean with a damp cloth, then a dry cloth to preserve the original luster and beauty of this fine finish.
- Do not** use abrasive chemicals.
- Do not** spray cleaners directly onto furniture.
- Lift slightly when moving on carpeting to prevent leg breakage.
- Use of a vaporizer near furniture will cause wood to swell and finish to peel.

⚠️ ADVERTENCIA



Han muerto niños debido a volcaduras de muebles. Para prevenir volcaduras:

- Instalar SIEMPRE el dispositivo anti-volcaduras incluido.
- No colocar NUNCA un televisor en este producto.
- Nunca permita que los niños trepen sobre cajones, puertas o baldas de estantería ni que se cuelguen de ellos.
- Nunca abra más de un cajón al mismo tiempo.
- Coloque los artículos de mayor peso en los cajones inferiores.



INFORMACIÓN SOBRE EL MONTAJE:

- Durante el proceso de montaje, ya utilice pernos o tornillos, compruebe cada uno de ellos colocando el perno/tornillo en el diagrama del artículo donde está dibujado el tamaño y el diseño real. Asegúrese de que utiliza el tamaño y la forma adecuada que especifican las instrucciones.
- Para montar esta unidad, puede que se le solicite que coloque la unidad de lado y de cara. Se recomienda encarecidamente que realice el montaje sobre una superficie no abrasiva (Como la envoltura de embalaje de espuma) para evitar dañar el acabado.

INFORMACIÓN SOBRE EL USO:

Mantenga a los niños y otras personas a salvo siguiendo estas sencillas reglas:

- **No permita** que ningún niño juegue sobre muebles.
- **No permita** que nadie trepe sobre un mueble.
- **No permita** que nadie se cuelgue de un mueble.
- Vigile siempre la actividad de su hijo cuando se encuentre en su cuarto.

NOTAS SOBRE SU CUIDADO Y MANTENIMIENTO:

- **No** arañe ni desconche el acabado.
- Inspeccione el producto con regularidad, póngase en contacto con Delta Children's Products para el recambio de partes o para formular preguntas.
- **No** guarde el producto ni ninguna de sus partes a temperaturas ni en condiciones extremas como un ático caluroso o un sótano húmedo y frío. Estos extremos pueden provocar una pérdida de integridad estructural.
- Para preservar el brillo del acabado de alta calidad que recubre su producto, se recomienda que coloque un paño o una almohadilla de fieltro debajo de cualquier objeto que coloque sobre el acabado.
- Límpielo con un trapo húmedo y luego con uno seco para preservar el brillo y la belleza originales de este fino acabado.
- No** utilice productos químicos abrasivos.
- No** pulverice limpiadores directamente sobre el mueble.
- Elévelo ligeramente cuando lo mueva sobre alfombras o moqueta para evitar que se rompan las patas.
- El uso de vaporizadores cerca de muebles puede provocar que la madera se hinche y acabe desconchándose.

PARTS: MAKE SURE THAT ALL PRE-ASSEMBLED PARTS ARE TIGHT
PIEZAS: ASEGÚRESE DE QUE TODAS LAS PIEZAS PRE-ENSAMBLADAS ESTÁN BIEN APRETADAS.

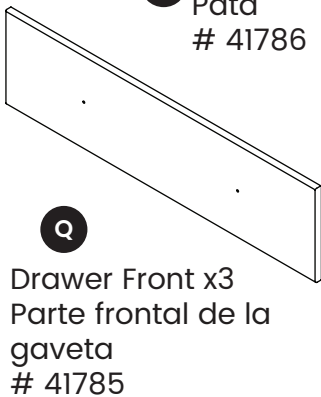
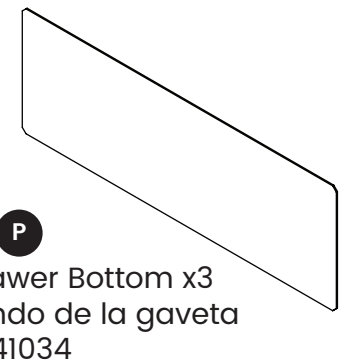
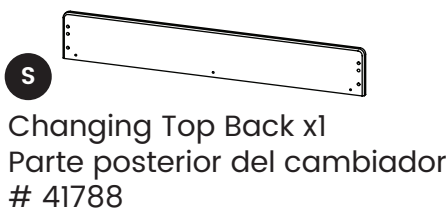
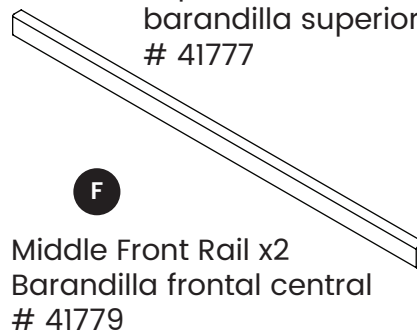
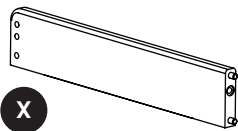
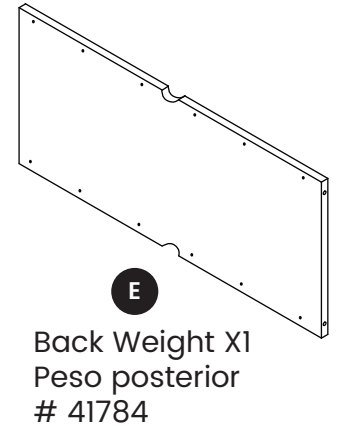
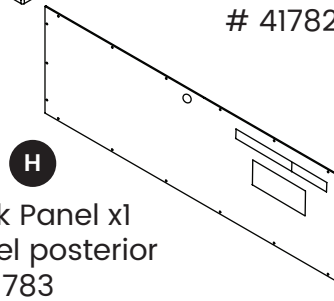
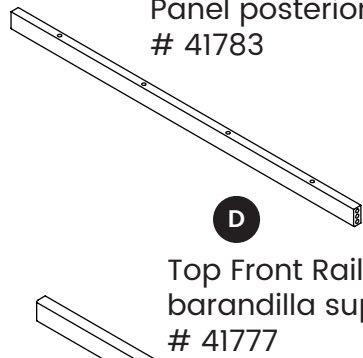
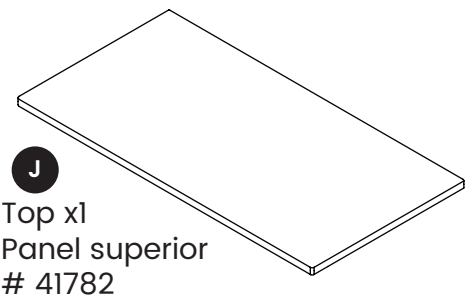
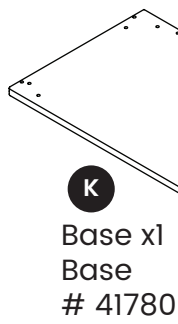
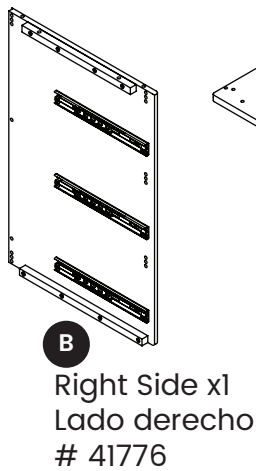
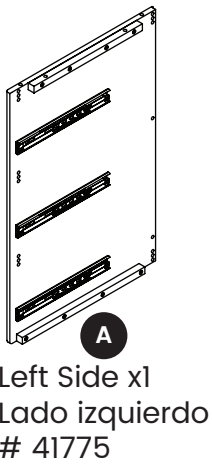

PARTS: HARDWARE KITS PART#41791
PIEZAS: EL KIT DE HERRAMIENTAS - PIEZA #41791

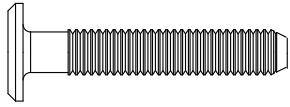

DD 35mm Bolt x16
Perno 35mm

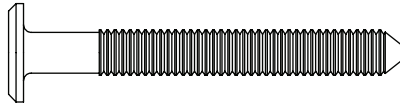

BB 50mm Bolt x22
Perno 50mm

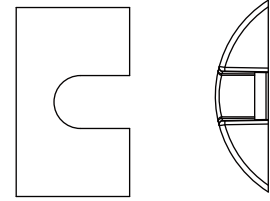

CC Crescent Washer x10
Arandela de Media Luna

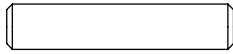

KK M6 x 30mm Wood Dowel x6
Pasador de Madera M6 x 30mm

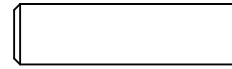

FF M8 x 30mm Wood Dowel x36
Pasador de Madera M8 x 30mm

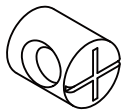

GG Plastic Barrel Nut x15
Tuerca de Barril Plásticas

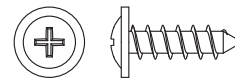

EE 15mm Back Panel Screw x18
Tornillo de Panel Trasero

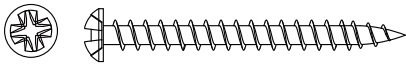

JJ 40mm Screw x18
Tornillo 40mm

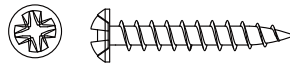

HH 25mm Screw x15
Tornillo 25mm



AA 12mm Screw x18
Tornillo 12mm

MM Knob / Perilla x6
#41793

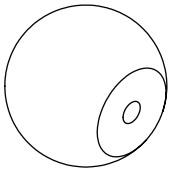

MM1 Knob
Perilla



MM2 Knob Screw
Tornillo para Perilla

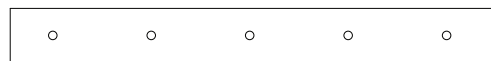

ZZ Wall Strap x1
Abrazadera

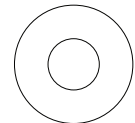

TT Washer x2
Arandela

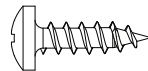

YY Short Screw x1
Tornillo corto

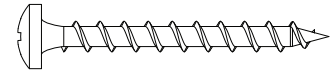

XX Long Screw x1
Tornillo Largo

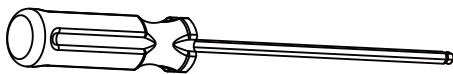

M4 Ballend Screwdriver
destornillador M4 con cabeza de bola



M4 Allen Wrench
Llave Allen M4



Phillips Screwdriver – Not included
Destornillador Phillips – no incluido

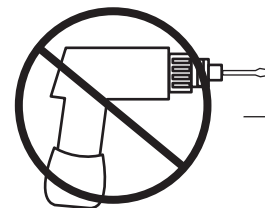

No drills necessary.
Do not use power screwdriver.

No hace falta taladrar.
No utilice destornilladores eléctricos

Hardware System - Review Before Assembly Revise Antes De Armar- Elementos De Fijacion Y Ensamble

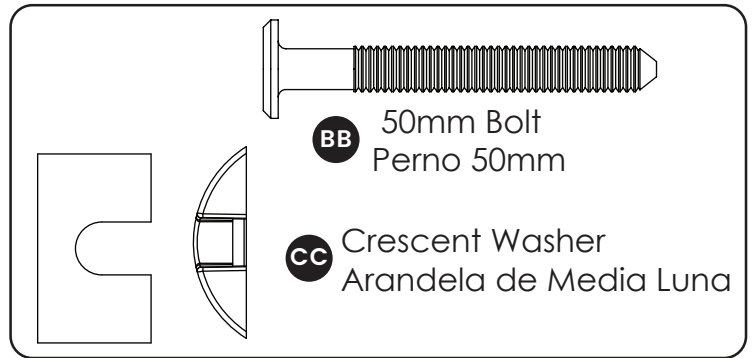
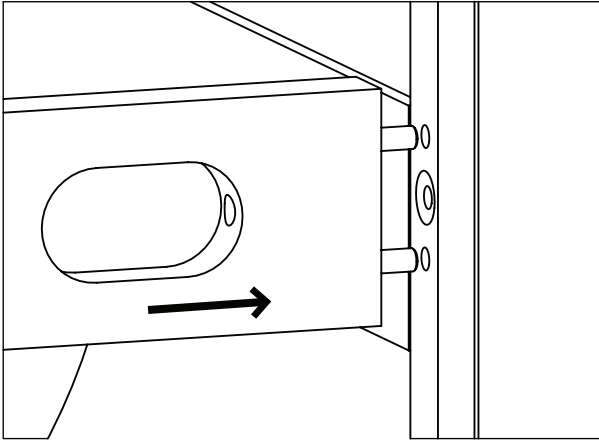

1. Insert the Dowels in the Rail into the holes in the Post.

1. Inserte los pasadores del Riel en los agujeros del Poste.

2. Insert the Bolt into the slot. Turn clockwise with fingers or the Ball End Screwdriver provided. DO NOT fully tighten, leave 1/2" (12mm) exposed.

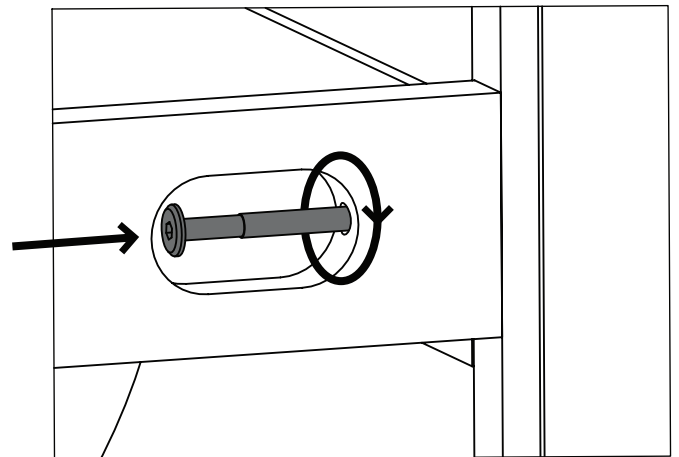

2. Inserte el perno en la ranura. Gírelo en el sentido de las agujas del reloj con los dedos o con el destornillador con cabeza de bola. NO lo apriete del todo, deje 1/2" (12 mm) fuera.

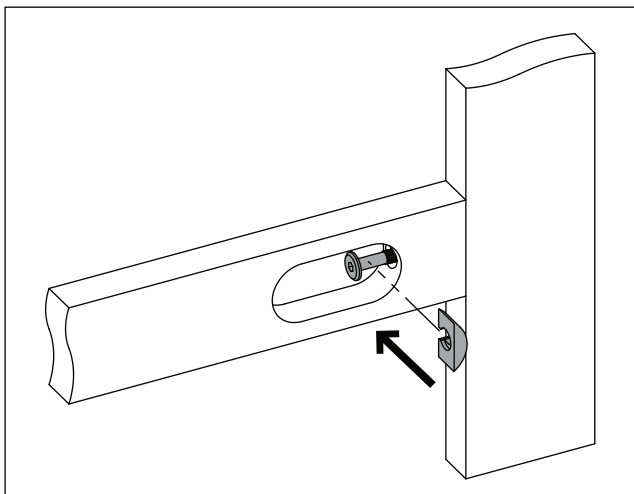

3. Slide the Crescent Washer over the exposed bolt, behind the head of the bolt.

3. Abrace la parte del Perno que quedó fuera, debajo de la cabeza del mismo, con la Arandela de media luna.

Install (1) bolt and (1) crescent washer at a time. Tighten until it looks like the picture.

Instale (1) perno y (1) Arandela de media luna al mismo tiempo. Apriételos hasta que quede como en la ilustración.

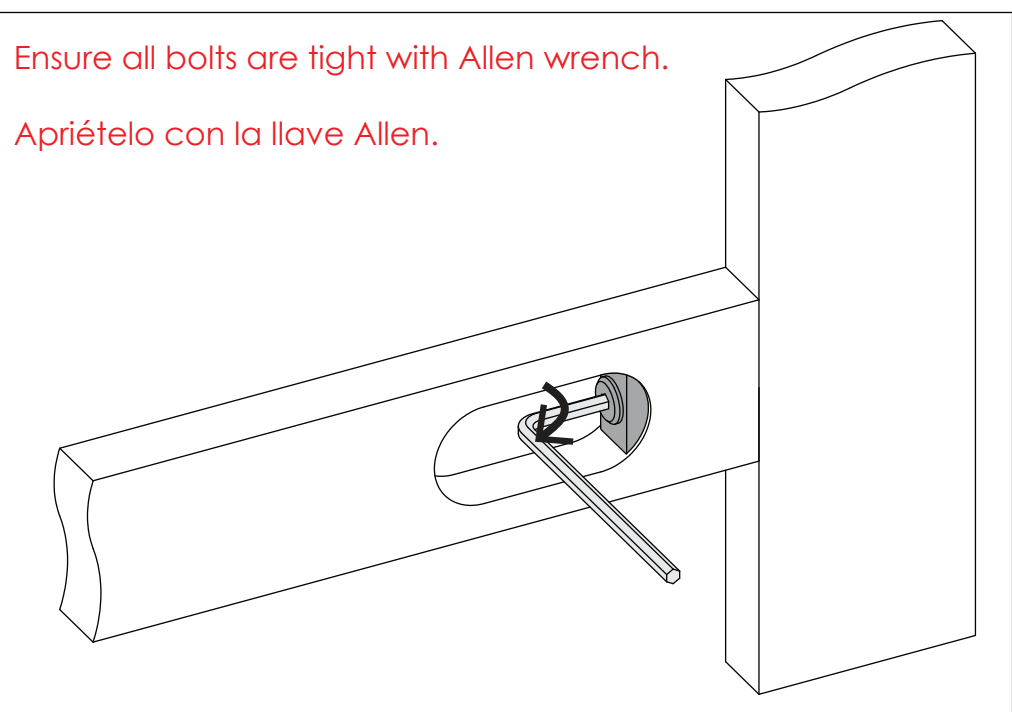
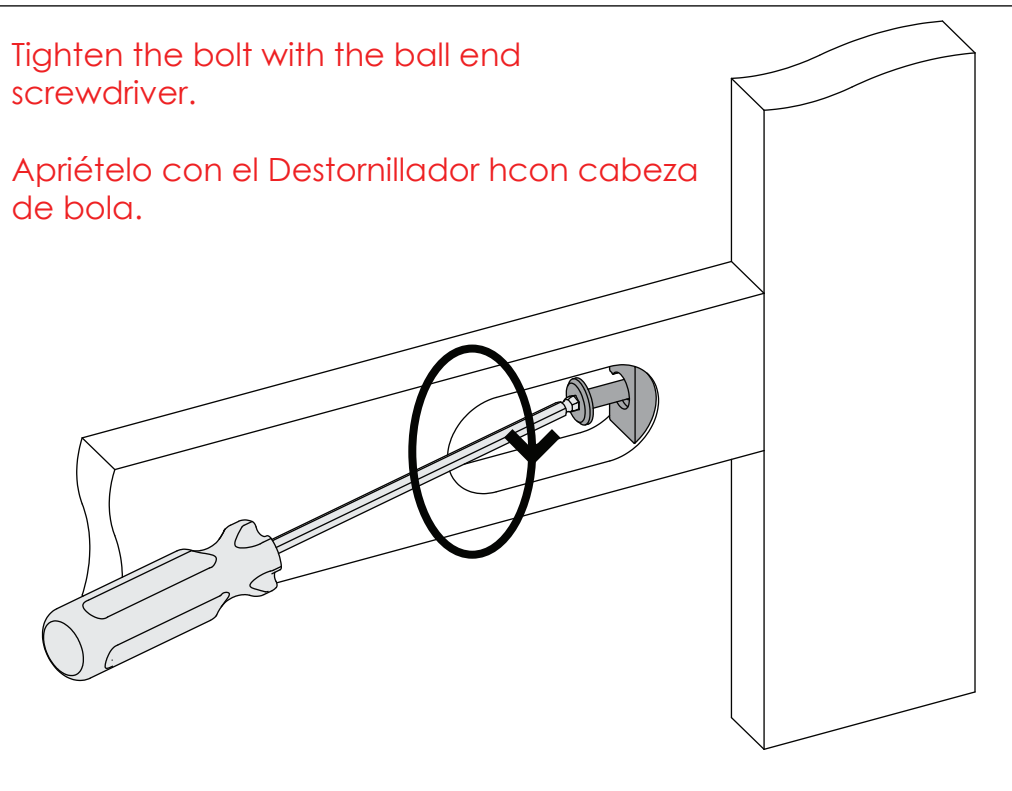

STEP 1
PASO 1

Parts and tools required to complete step
Piezas y herramientas necesarias para completar este paso

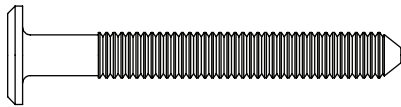

BB 50mm Bolt x3
Perno 50mm

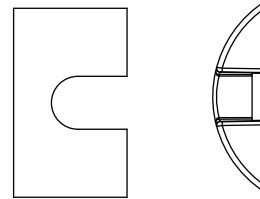

CC Crescent Washer x3
Arandela de Media Luna



FF M8 x 30mm Wood Dowel x6
Pasador de Madera M8 x 30mm



M4 Ball End Screwdriver
M4 destornillador hexagonal



M4 Allen Wrench
Llave Allen

Attach Top Front Rail (Part D) and (2) Middle Front Rails (Part F) to the Left Side (Part A) using (6) M8 x 30mm Wood Dowels (Part FF), (3) Crescent Washers (Part CC), and (3) 50mm Bolts (Part BB) with the Ball End Screwdriver and the Allen Wrench following the instructions on pages 14 and 15.

Fijar la barandilla superior frontal (pieza D) y (2) barandillas frontales centrales (pieza F) con el lado izquierdo (pieza A) utilizando (6) pasadores de madera M8 x 30mm (pieza FF), (3) arandelas de media luna (pieza CC), y (3) pernos de 50 mm (pieza BB) con el destornillador hexagonal y la llave Allen, siguiendo las instrucciones de las páginas 14 y 15.

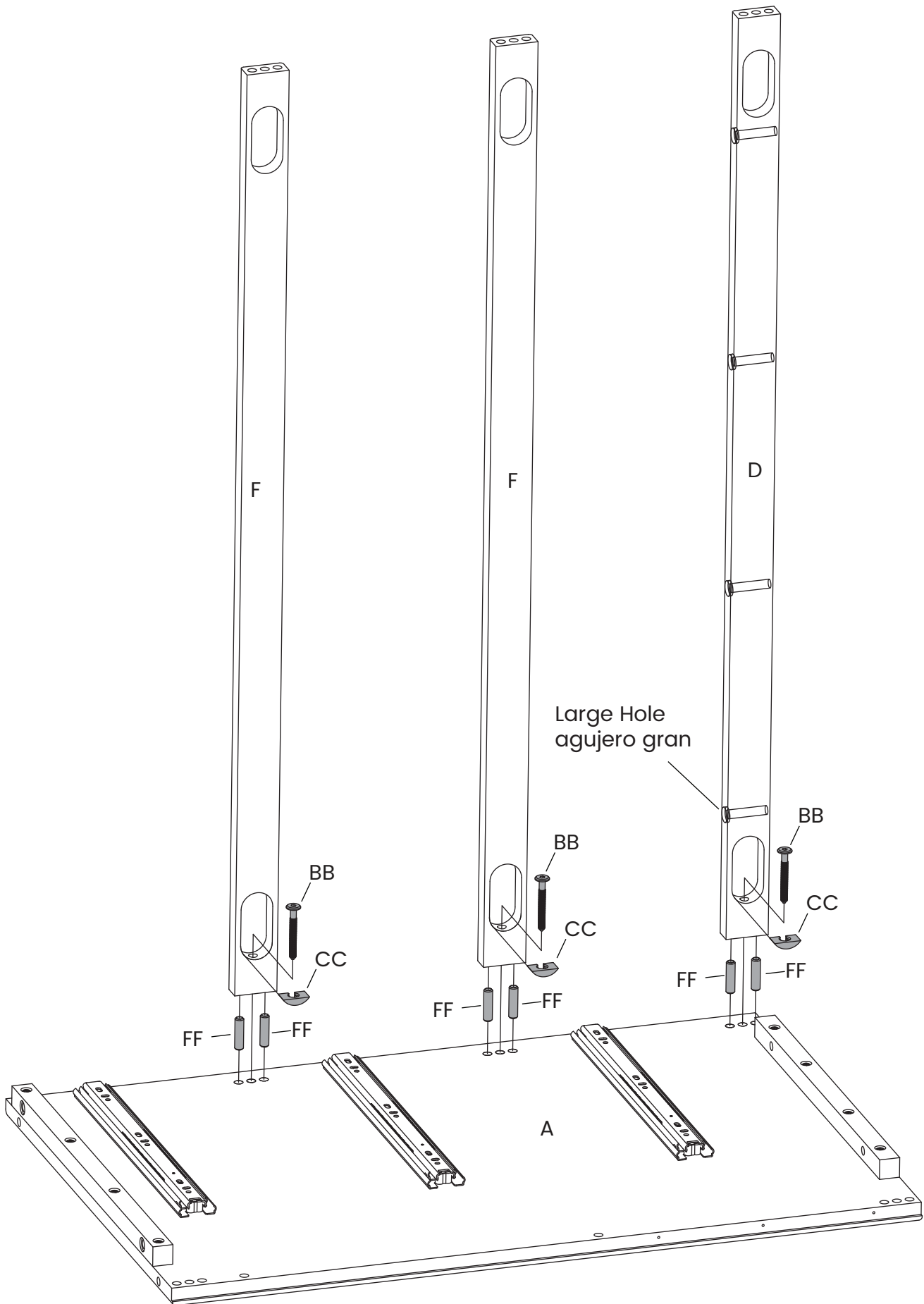

STEP 2 PASO 2

Parts and tools required to complete step

Piezas y herramientas necesarias para completar este paso

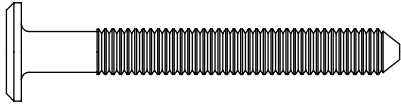

BB 50mm Bolt x2
Perno 50mm

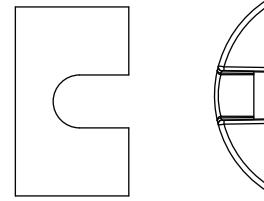

CC Crescent Washer x2
Arandela de Media Luna

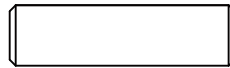

FF M8 x 30mm Wood Dowel x4
Pasador de Madera M8 x 30mm



M4 Ball End Screwdriver
M4 destornillador hexagonal



M4 Allen Wrench
Llave Allen

Attach Top Back Rail (Part C) and Bottom Back Rail (Part G) to the Left Side (Part A) using (4) M8 x 30mm Wood Dowels (Part FF), (2) Crescent Washers (Part CC), and (2) 50mm Bolts (Part BB) with the Ball End Screwdriver and the Allen Wrench following the instructions on pages 14 and 15.

Fijar la barandilla superior posterior (pieza C) y la barandilla inferior posterior (pieza G) con el lado izquierdo (pieza A) utilizando (4) pasadores de madera M8 x 30mm (pieza FF), (2) arandelas de media luna (pieza CC) y (2) pernos de 50 mm (pieza BB) con el destornillador hexagonal y la llave Allen, siguiendo las instrucciones en las páginas 14 y 15.

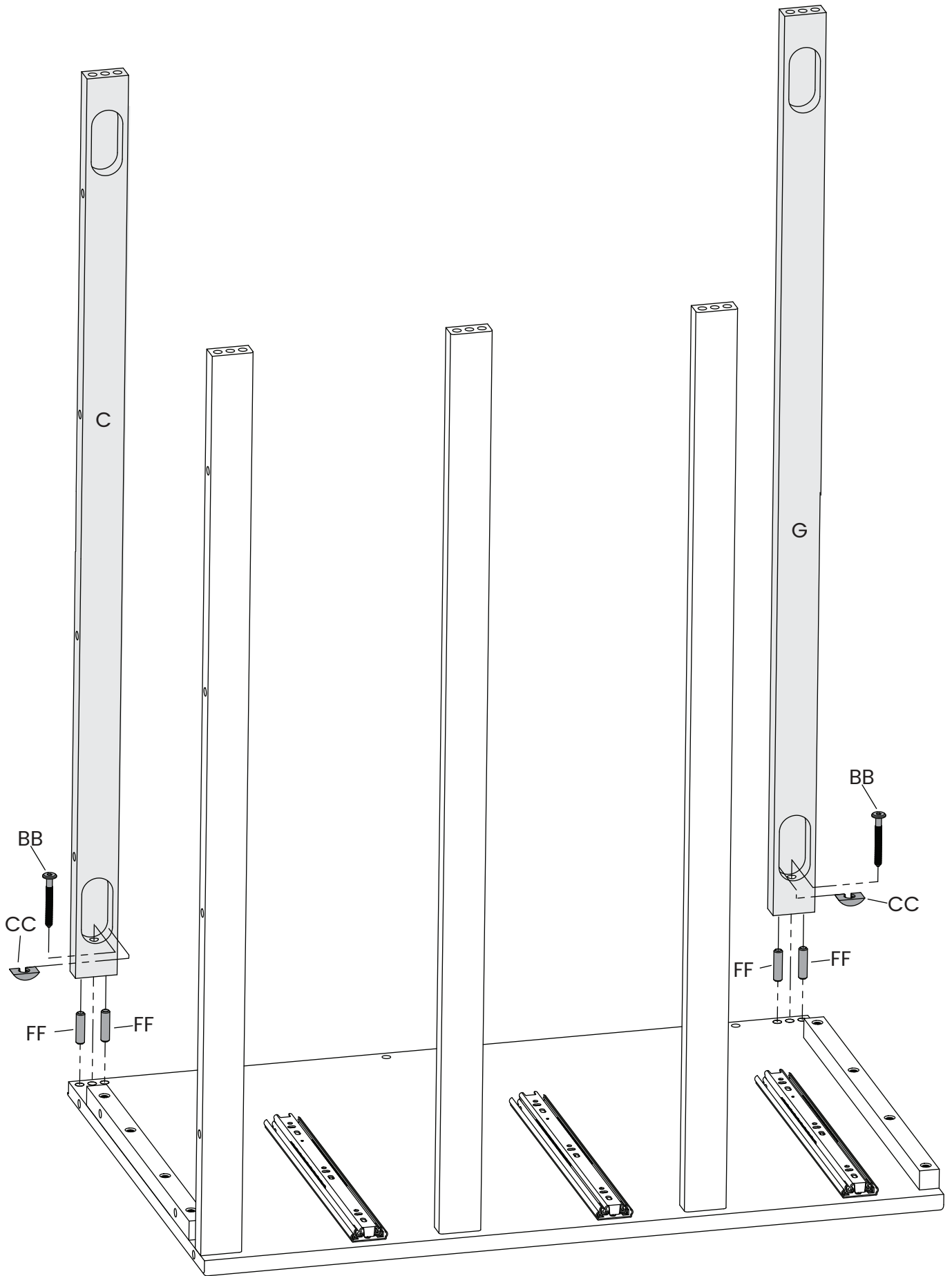

STEP 3
PASO 3

Parts and tools required to complete step

Piezas y herramientas necesarias para completar este paso

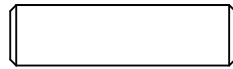

- FF** M8 x 30mm Wood Dowel x14
Pasador de Madera M8 x 30mm

Attach Back Weight (Part E) to Case Assembly from Step #2 using (2) Wood Dowels (Part FF). Then install (12) Wood Dowels (Part FF) into the Drawer Rails and Back Weight.

Fijar el peso posterior (pieza E) al ensamblado del paso # 2 utilizando (2) pasadores de madera (pieza FF). Luego, instalar (12) pasadores de madera (pieza FF) en los rieles de las gavetas y el peso posterior.

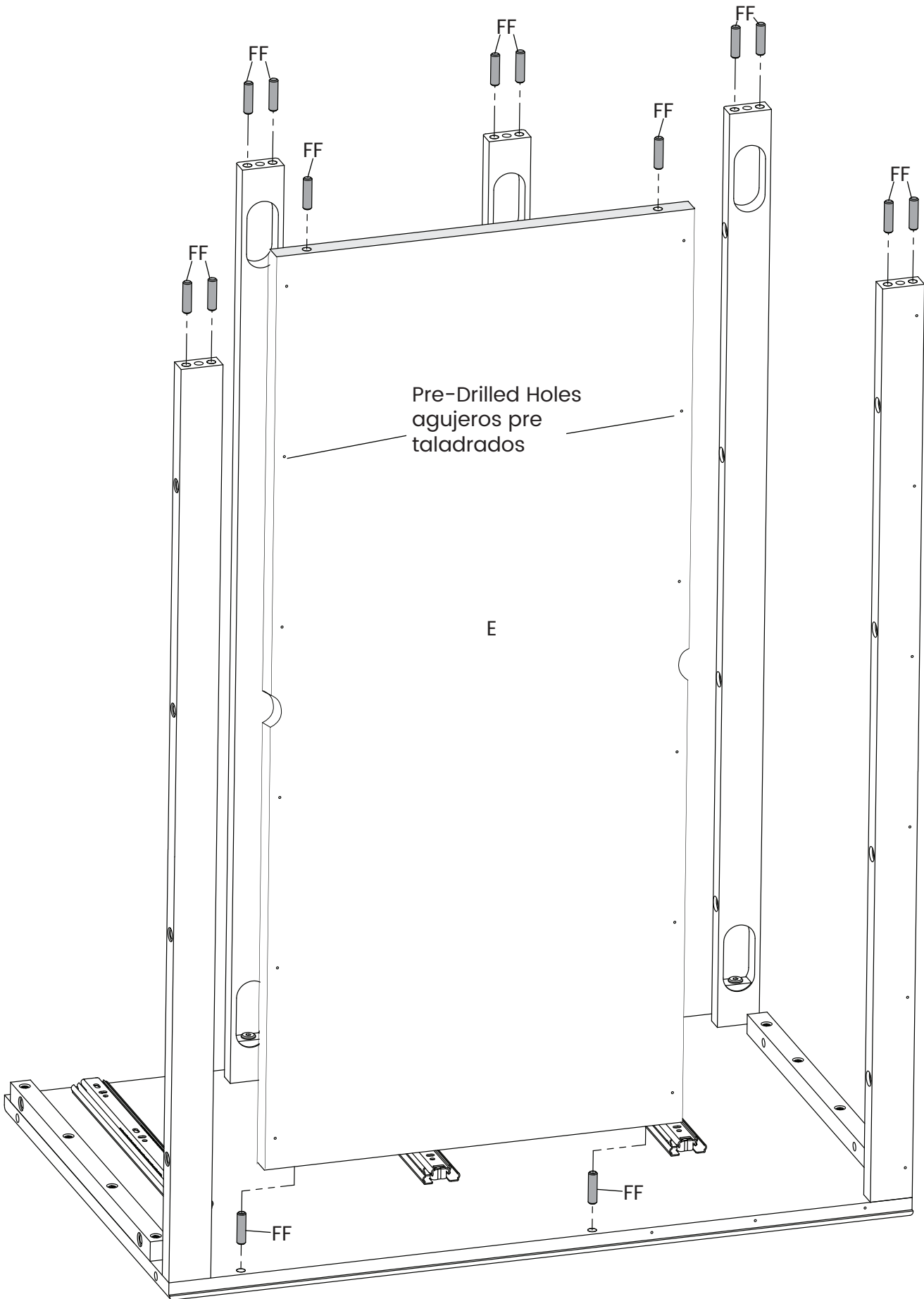

STEP 4 PASO 4

Parts and tools required to complete step

Piezas y herramientas necesarias para completar este paso

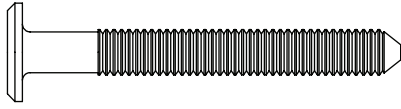

BB 50mm Bolt x5
Perno 50mm

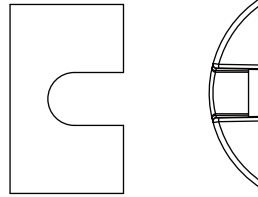

CC Crescent Washer x5
Arandela de Media Luna



M4 Ball End Screwdriver
M4 destornillador hexagonal



M4 Allen Wrench
Llave Allen

Attach Right Side (Part B) to the case assembly from Step #3 using (5) 50mm Bolts (Part BB) and (5) Crescent Washers (Part CC). Carefully align all dowels and holes, then install the Bolts and Crescent Washers with the Ball End Screwdriver and the Allen Wrench following the instructions on page 14 and 15.

Fijar el lado derecho (pieza B) a lo ya ensamblado en el paso # 3 utilizando (5) pernos de 50 mm (pieza BB) y (5) arandelas de media luna (pieza CC). Alinear con cuidado todos los pasadores con los agujeros, instalar luego los pernos y las arandelas de media luna utilizando el destornillador hexagonal y la llave Allen siguiendo las instrucciones de las páginas 14 y 15.

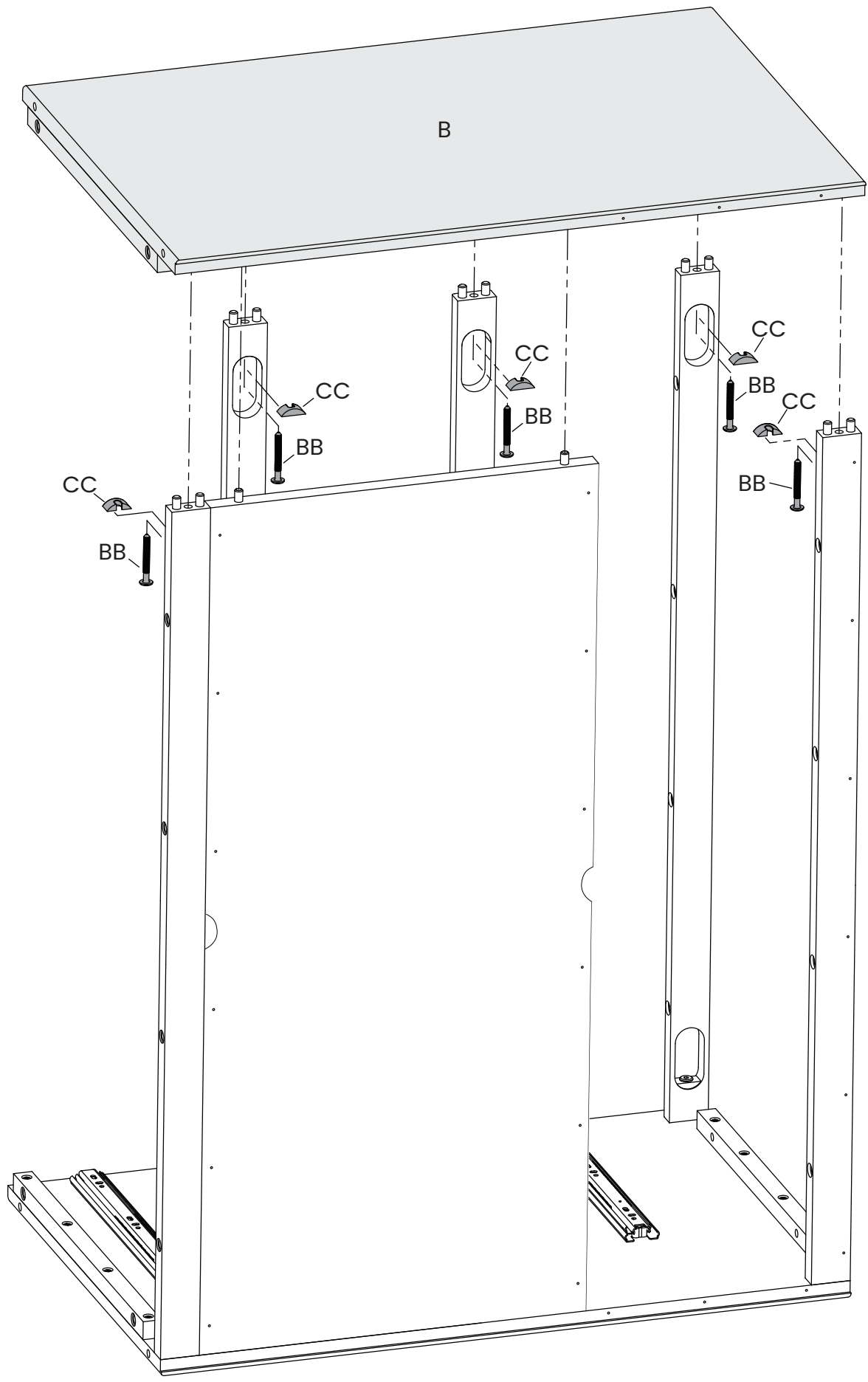

STEP 5 PASO 5

Parts and tools required to complete step

Piezas y herramientas necesarias para completar este paso

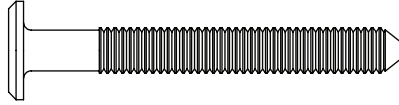

BB 50mm Bolt x8
Perno 50mm

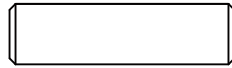

FF M8 x 30mm Wood Dowel x4
Pasador de Madera M8 x 30mm

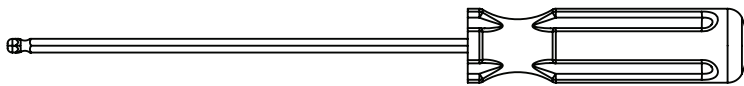

M4 Ball End Screwdriver
M4 destornillador hexagonal



M4 Allen Wrench
Llave Allen

Insert (4) M8 x 30mm Wood Dowels (Part FF) into the Left Side (Part A) and Right Side (Part B). Carefully align all dowels with the holes in the Top (Part J). Attach the Top (Part J) using (8) 50mm Bolts (Part BB). Tighten the bolts using the Ball End Screwdriver, then ensure the bolts are tight using the Allen Wrench like shown on page 15.

Insertar (4) pasadores de madera M8 x 30mm (pieza FF) en el lado izquierdo (pieza A) y en el lado derecho (pieza B). Alinear con cuidado todos los pasadores con los agujeros del panel superior (pieza J). Fijar el panel superior (pieza J) utilizando (8) pernos de 50mm (pieza BB). Apretar los pernos utilizando el destornillador hexagonal. Asegurarse de que todos los pernos estén apretados utilizando la llave Allen como se muestra en la página 15.

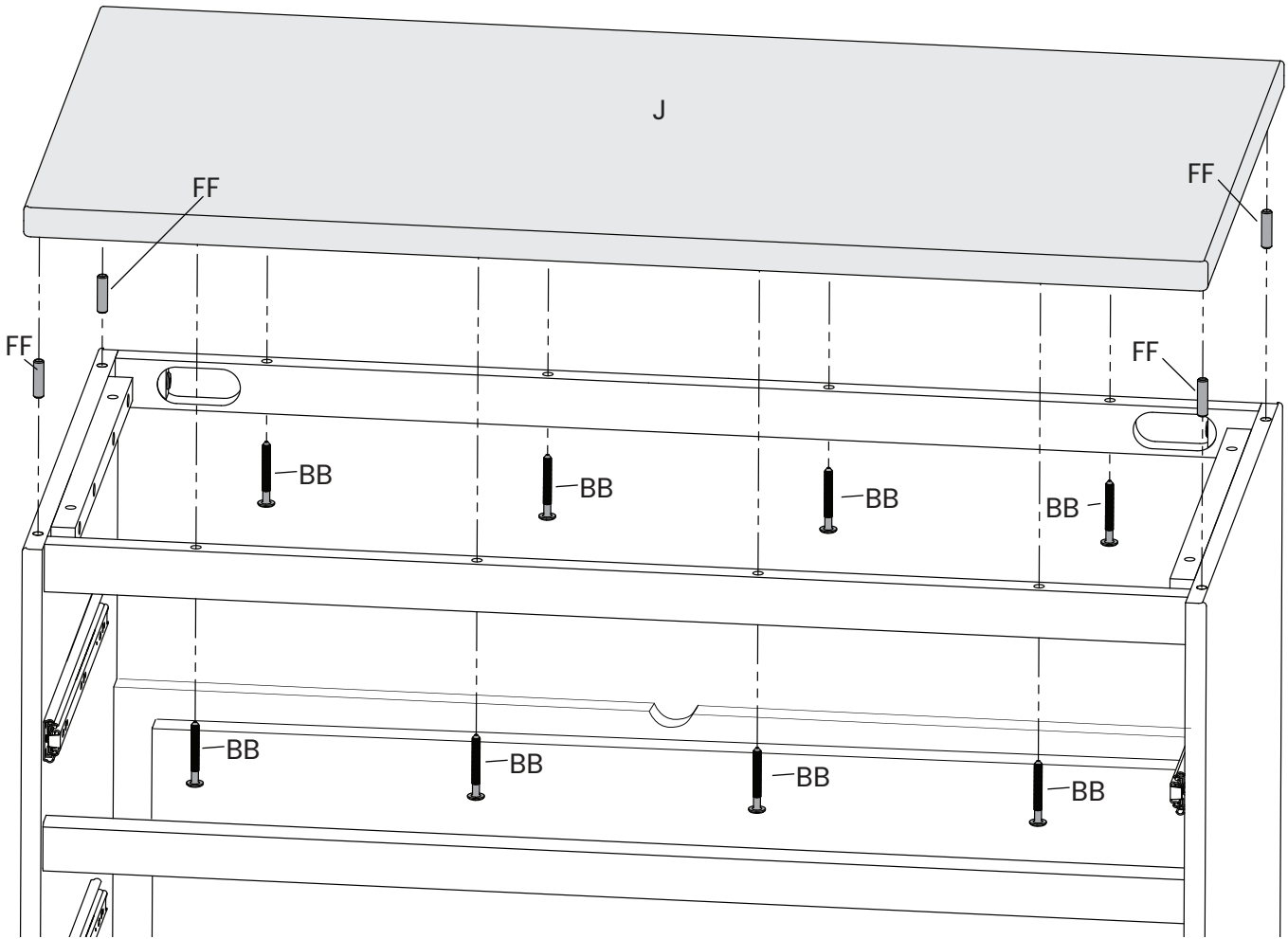

STEP 6
PASO 6

Parts and tools required to complete step

Piezas y herramientas necesarias para completar este paso

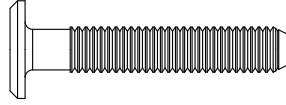
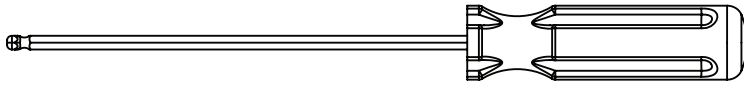
35mm Bolt x4
Perno 35mmM4 Ball End Screwdriver
M4 destornillador hexagonalM4 Allen Wrench
Llave Allen

Attach the Top (Part J) using (4) 35mm Bolts (Part DD). Tighten the bolts using the Ball End Screwdriver, then ensure the bolts are tight using the Allen Wrench like shown on page 15.

Fijar el panel superior (pieza J) utilizando (4) pernos de 35mm (pieza DD). Apretar los pernos utilizando el destornillador hexagonal. Asegurarse de que todos los pernos estén apretados utilizando la llave Allen como se muestra en la página 15.

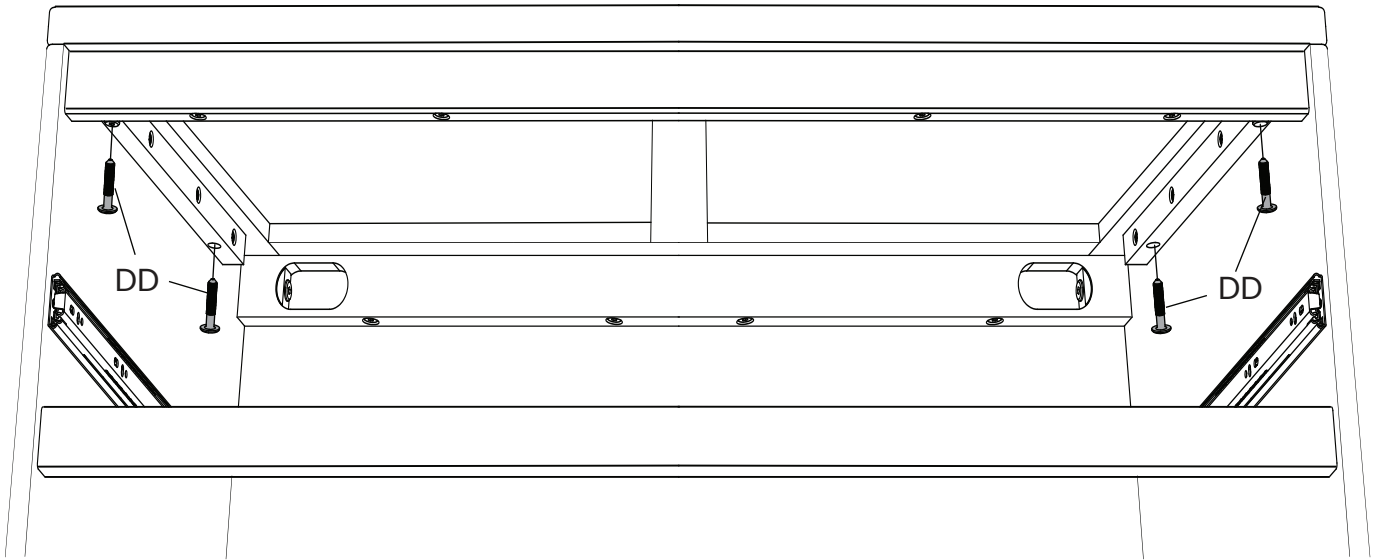

STEP 7 PASO 7

Parts and tools required to complete step
Piezas y herramientas necesarias para completar este paso

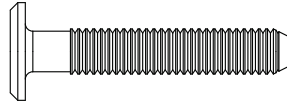

DD 35mm Bolt x8
Perno 35mm

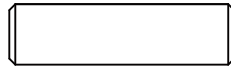

FF M8 x 30mm Wood Dowel x4
Pasador de Madera M8 x 30mm



M4 Ball End Screwdriver
M4 destornillador hexagonal



M4 Allen Wrench
Llave Allen

Attach Base (Part K) to Case Assembly from Step #5 using (4) M8 x 30mm Dowels (Part FF) and (8) 35mm Bolts (Part DD). Tighten the bolts using the Ball End Screwdriver, then ensure the bolts are tight using the Allen Wrench like shown on page 15.

Fijar la base (pieza K) a lo ensamblado en el paso #5 utilizando (4) pasadores M8 x 30mm pieza (FF) y (8) pernos de 35mm (pieza DD). Apretar los pernos utilizando el destornillador hexagonal. Asegurarse de que todos los pernos estén apretados utilizando la llave Allen como se muestra en la página 15.

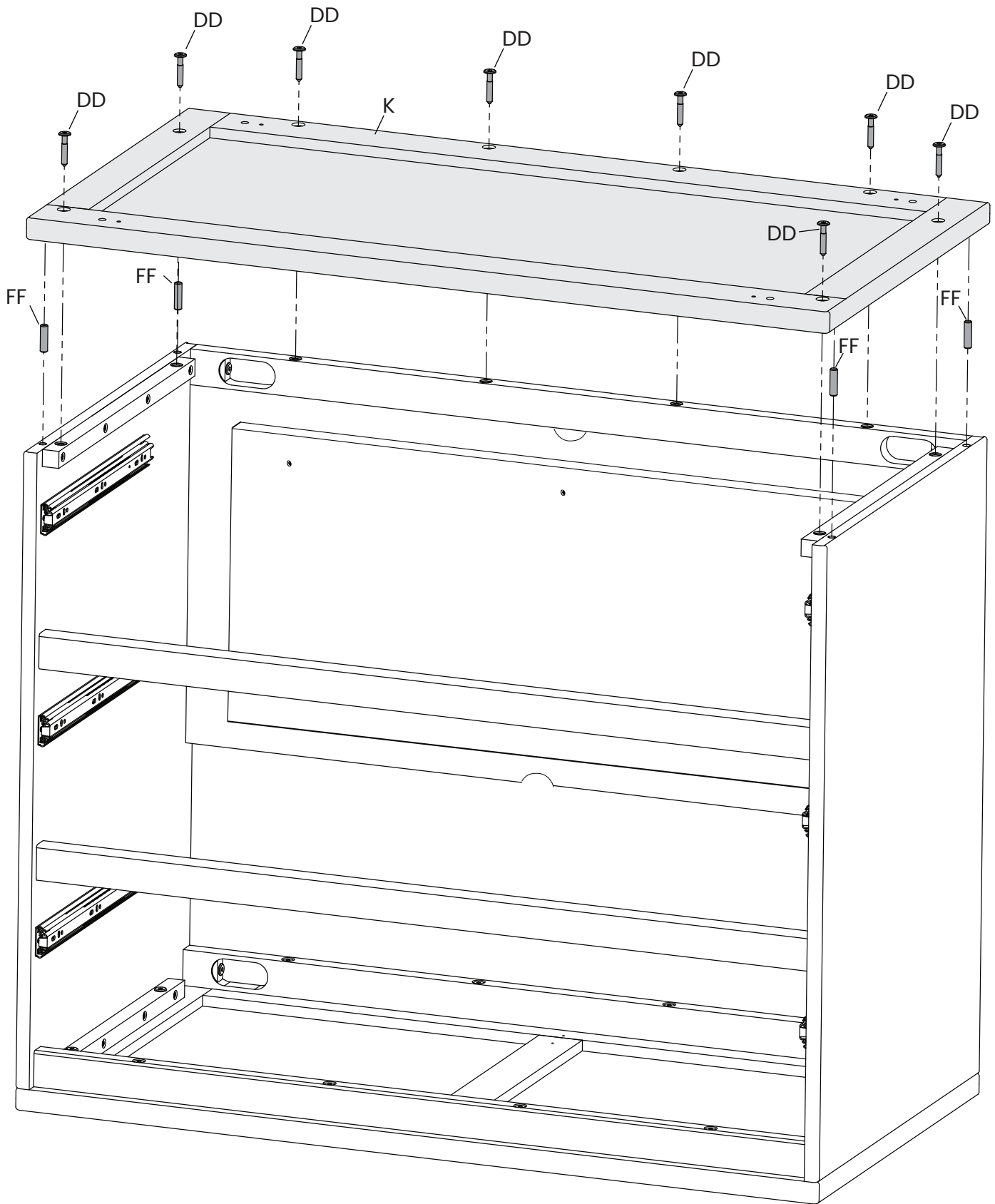

STEP 8 PASO 8

Parts and tools required to complete step

Piezas y herramientas necesarias para completar este paso

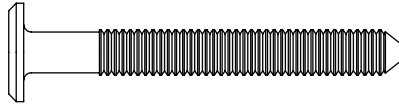

BB 50mm Bolt x4
Perno 50mm

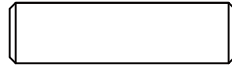

FF M8 x 30mm Wood Dowel x4
Pasador de Madera M8 x 30mm



M4 Ball End Screwdriver
M4 destornillador hexagonal



M4 Allen Wrench
Llave Allen

Attach (4) Feet (Part R) to Case Assembly from Step #6 using (4) M8 x 30mm Wood Dowels (Part FF) and (4) 50mm Bolts (Part BB). Tighten the bolts using the Ball End Screwdriver, then ensure the bolts are tight using the Allen Wrench like shown on page 15.

Fijar (4) patas (pieza R) a lo ensamblado en el paso #6 utilizando (4) pasadores de Madera M8 x 30mm (pieza FF) y (4) pernos de 50mm (pieza BB). Apretar los pernos utilizando el destornillador hexagonal. Asegurarse de que todos los pernos estén apretados utilizando la llave Allen como se muestra en la página 15.

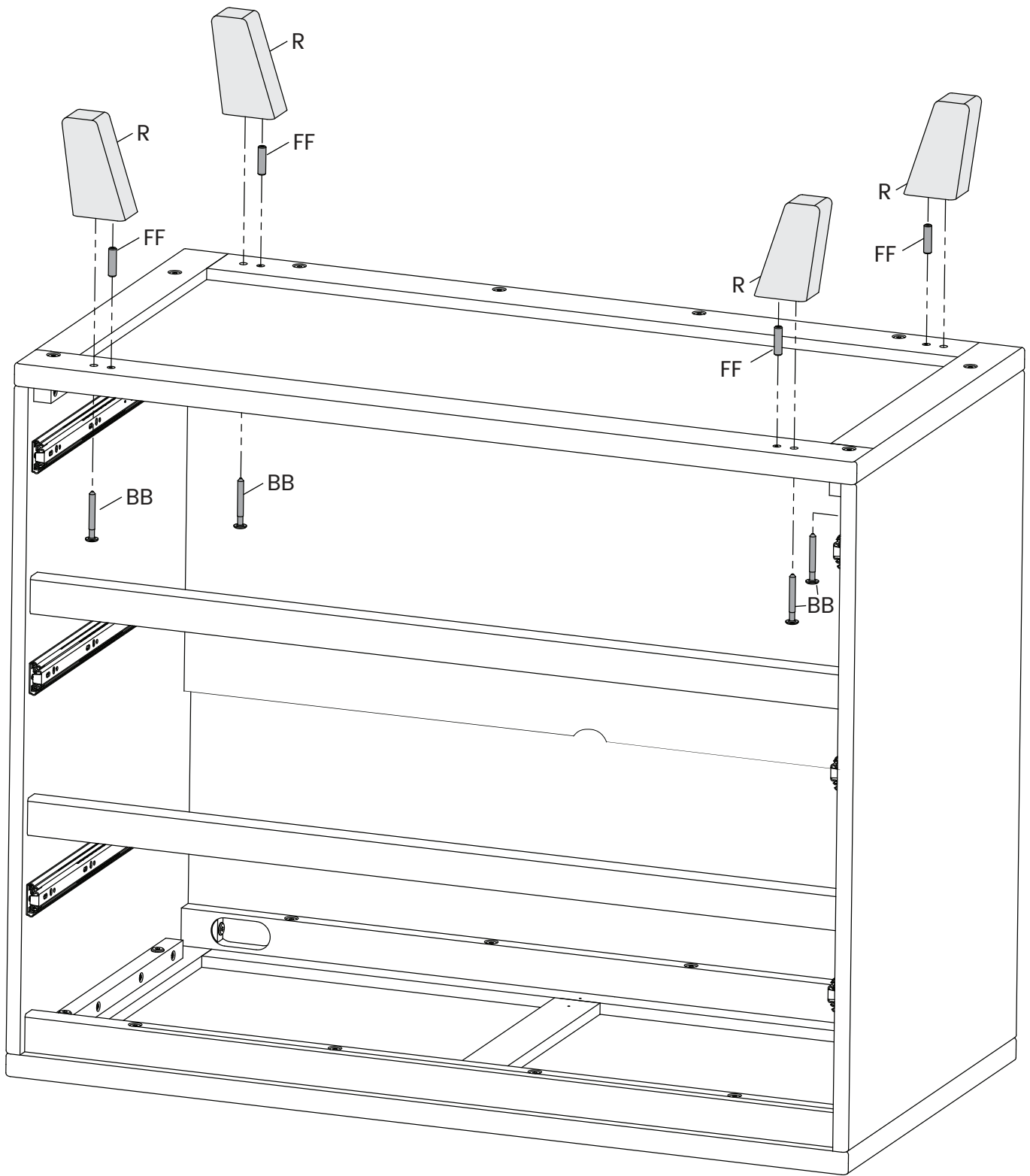

STEP 9 PASO 9

Parts and tools required to complete step
Piezas y herramientas necesarias para completar este paso

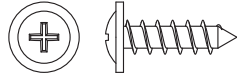

EE 15mm Back Panel Screw x18
Tornillo de Panel Trasero

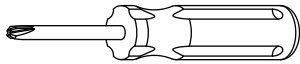

Phillips Screwdriver – Not included
Destornillador Phillips – no incluido

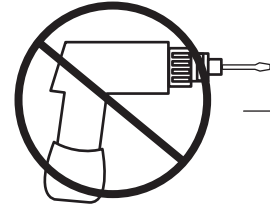

No drills necessary.
Do not use power screwdriver.

No hace falta taladrar.
No utilice destornilladores eléctricos

Attach the Back Panel (Part H) using (18) 15mm Screws (Part EE), tighten with a Phillips screwdriver. Ensure the "Delta Address Label" faces out.

Una el panel posterior (Pieza H) utilizando (18) tornillos de 15 mm (Pieza EE), apriete utilizando un destornillador Phillips. Asegúrese de que la etiqueta "Delta Address Label" quede boca abajo.

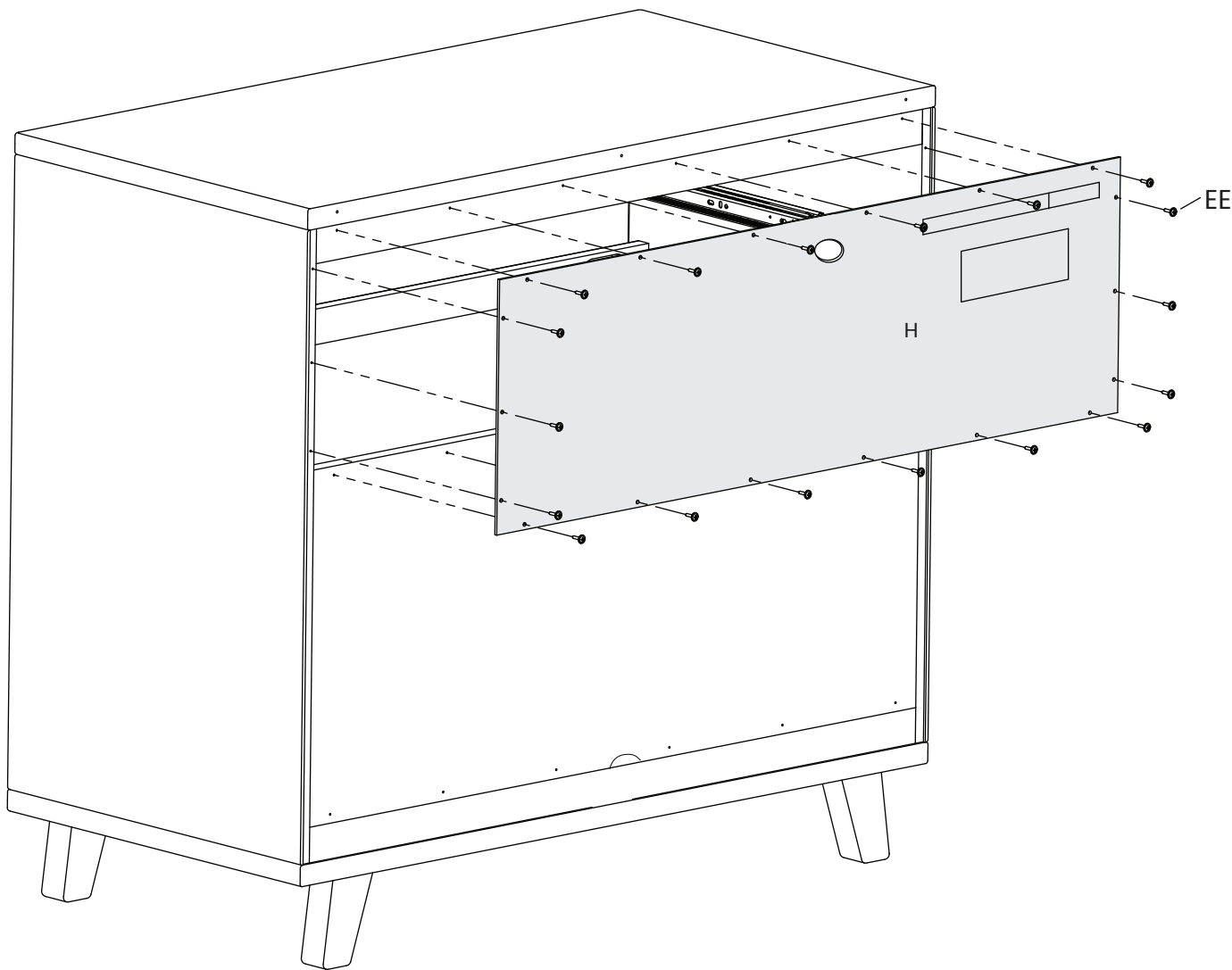

STEP 10 PASO 10

Parts and tools required to complete step
Piezas y herramientas necesarias para completar este paso

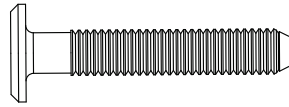

DD 35mm Bolt x2
Perno 35mm

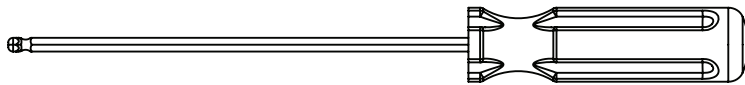

M4 Ball End Screwdriver
M4 destornillador hexagonal



M4 Allen Wrench
Llave Allen

1. Attach Changing Top Right Side (Part W) to the Changing Top Front (Part T) using (1) 35mm Bolt (Part DD). Tighten the bolts using the Ball End Screwdriver, then ensure the bolts are tight using the Allen Wrench like shown on page 15.
2. Attach Changing Top Left Side (Part X) in the same manner.

1. Fijar el lado derecho del cambiador (pieza W) con la parte frontal del cambiador (pieza T) utilizando (1) perno de 35mm (pieza DD). Apretar el perno utilizando el destornillador hexagonal. Asegurarse de que el perno esté apretado utilizando la llave Allen como se muestra en la página 15.
2. Fijar el lado izquierdo del cambiador (pieza X) de la misma manera.

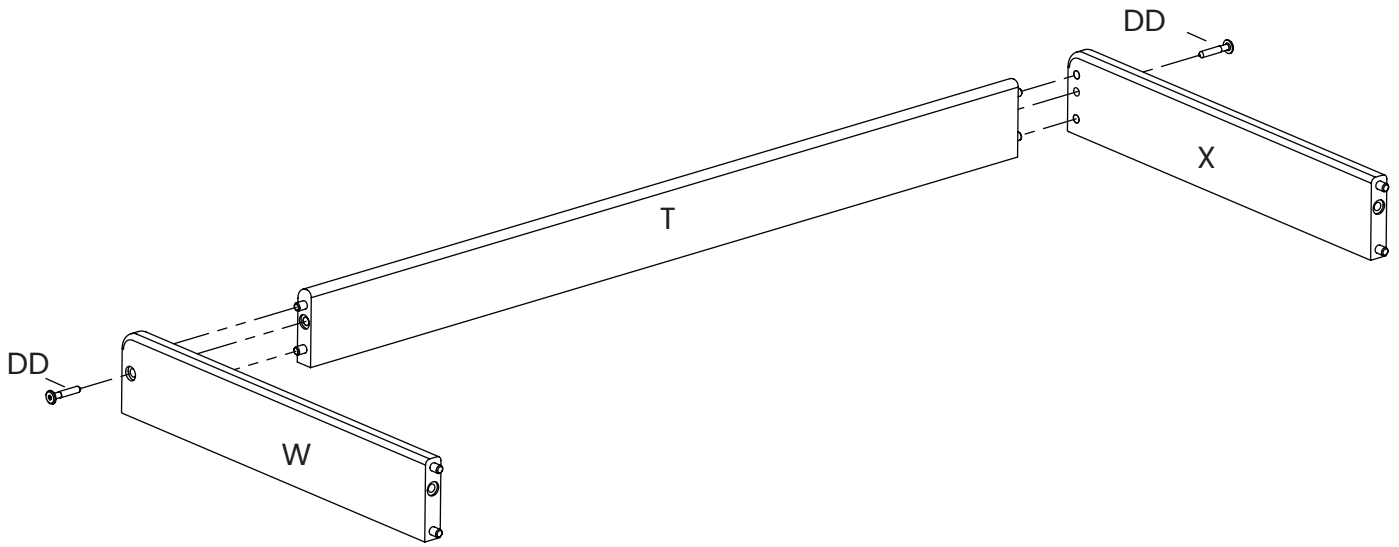

STEP 11

PASO 11

Parts and tools required to complete step

Piezas y herramientas necesarias para completar este paso

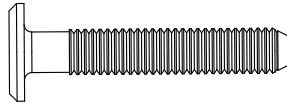

DD 35mm Bolt x2
Perno 35mm

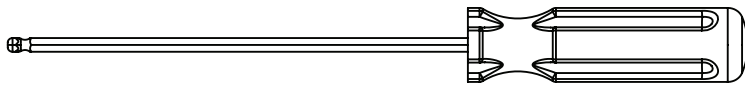

M4 Ball End Screwdriver
M4 destornillador hexagonal



M4 Allen Wrench
Llave Allen

1. Attach Changing Top Back (Part S) to the Right and Left Sides using (2) 35mm Bolts (Part DD) Tighten the bolts using the Ball End Screwdriver, then ensure the bolts are tight using the Allen Wrench like shown on page 15.

Fijar la parte posterior del cambiador (pieza S) a los lados derecho e izquierdo utilizando (2) pernos de 35mm (pieza DD). Apretar los pernos utilizando un destornillador hexagonal. Asegurarse de que los pernos estén apretados utilizando la llave Allen como se muestra en la página 15.

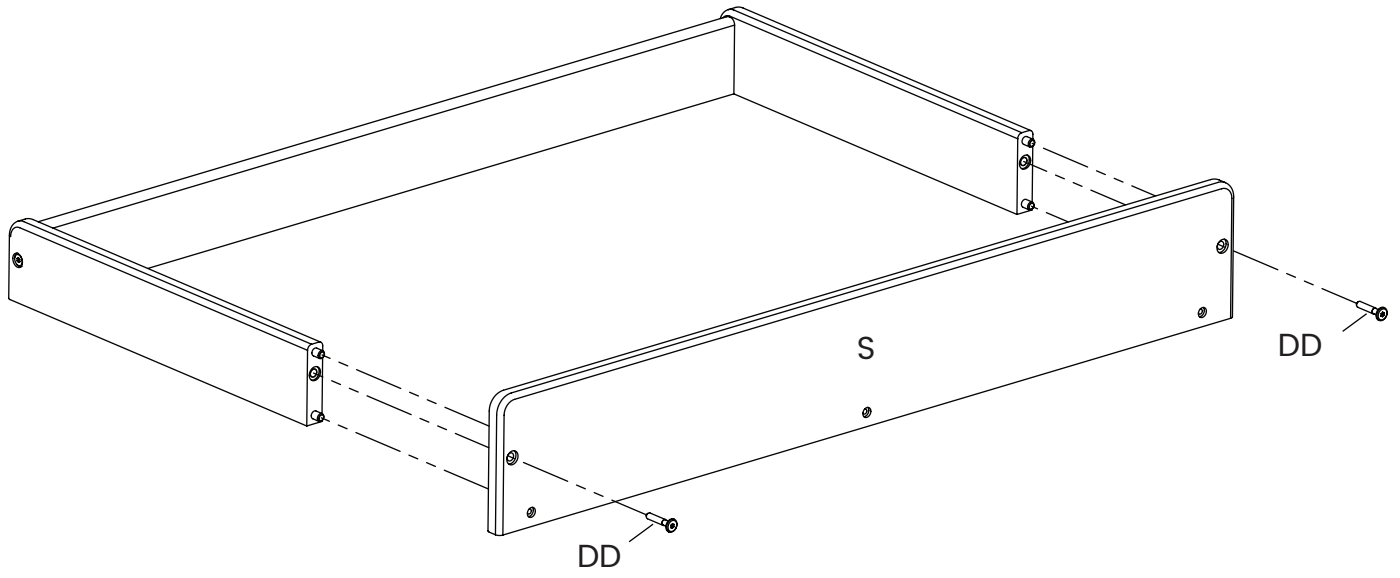

STEP 12

PASO 12

Parts and tools required to complete step

Piezas y herramientas necesarias para completar este paso

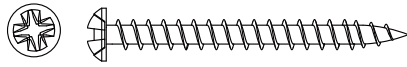

JJ 40mm Screw x3
Tornillo 40mm

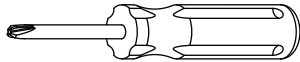

Phillips Screwdriver – Not included
Destornillador Phillips – no incluido

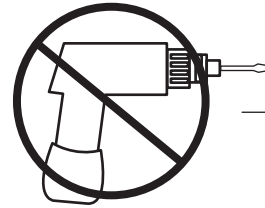

No drills necessary.
Do not use power screwdriver.

No hace falta taladrar.
No utilice destornilladores eléctricos

Attach Changing Top to Dresser using (3) 40mm Screws (Part JJ), insert the screws through the Changing Top into the pre-drilled holes in the Dresser Top. Tighten with Phillips Screwdriver.

Fijar el tablero cambiador a la cómoda utilizando (3) tornillos de 40mm (pieza JJ), insertar los tornillos a través del tablero cambiador y dentro de los agujeros ya perforados de la parte superior de la cómoda. Apriete con un destornillador de cruz.

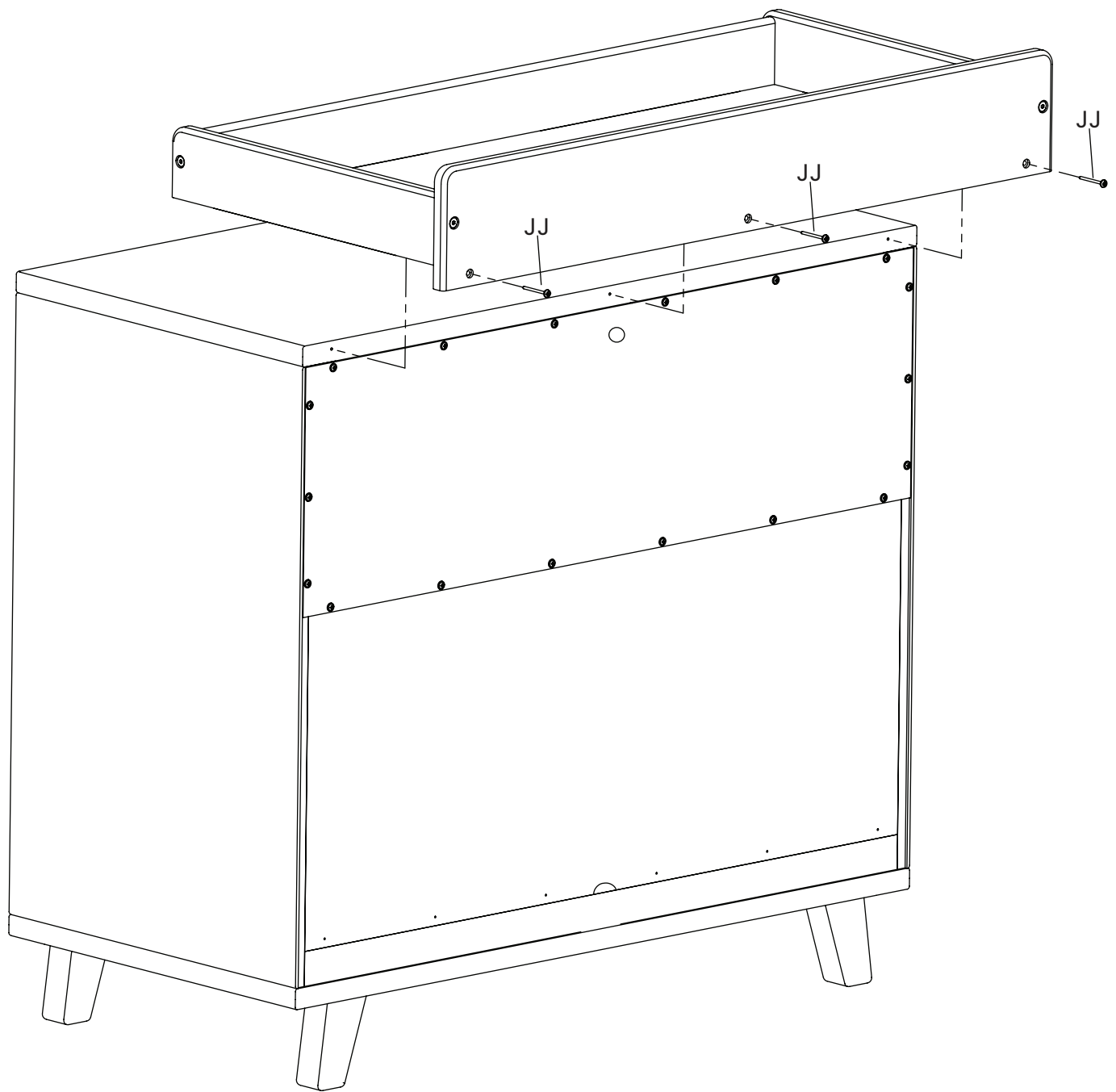

STEP 13
PASO 13

Tipover Restraint
Protección contra volcamiento

▲ WARNING
Use of tip-over restraints may only reduce, but not eliminate, the risk of tip-over.
Do not attempt to Screw into the wallboard only. You must Screw into a wood wall stud or other wood structure such as securely attached baseboard. If your wall is not wood stud construction, see your local hardware store or home center for a wall anchor system that will hold a pull force of 50 LBS in your wall type. If you are unsure of how to locate the wood stud, or of what type of wall you have, contact a professional contractor.

▲ ADVERTENCIA
El uso de herramientas de contención de vuelcos tan solo puede reducir, pero no eliminar, el riesgo de vuelco.
No intente atornillar a paredes hechas únicamente de paneles. Debe atornillar en un pilar u otra estructura de madera similar, como un zócalo fijado de manera segura. Si su pared no tiene vigas de Madera, visite su ferretería o tienda del ramo más cercana para conseguir un sistema de anclaje que soporte una fuerza de tiraje de hasta 50 LBS (22,7 Kgs) para su tipo de muro. Si no está seguro sobre cómo encontrar la viga de madera o tiene dudas sobre el tipo de muro, contacte a un contratista profesional.

- 1) Choose BOTTOM or TOP attachment.
- 2) Locate the through holes in the back of the dresser.
- 3) Align the hole to be used with the wood wall stud (For Open Bottom Installation, use wood wall stud closest to center)

- 1) Seleccione el aditamento SUPERIOR o INFERIOR.
- 2) Ubique los orificios pasantes en la parte posterior del mueble.
- 3) Alinee el orificio que utilizará con el pilar de la pared (para una instalación con fondo abierto, utilice el pilar de madera más cercano al centro)

4) Make a pencil mark on the wall using the wood rail as a guide, pencil mark must be over wood wall stud. Then move the case away from the wall.

4) Utilizando un lápiz, haga una marca en la pared utilizando el barra de madera como guía; la marca debe estar sobre el pilar de madera. Luego, aleje la carcasa de la pared.

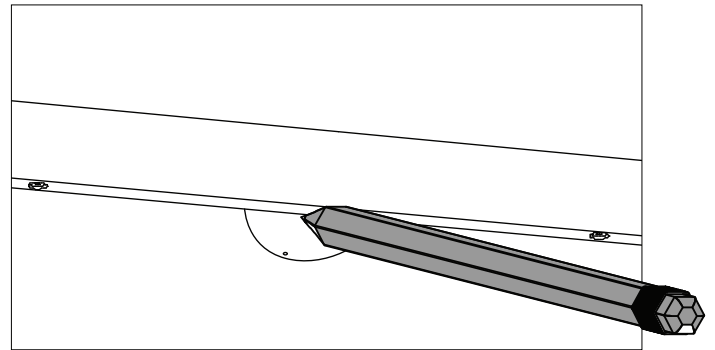

5) Drill $\varnothing 1/8"$ hole at Pencil Mark, in wood wall stud

5) Perfore un orificio de $\varnothing 1/8"$ en la marca del lápiz, sobre el pilar de madera

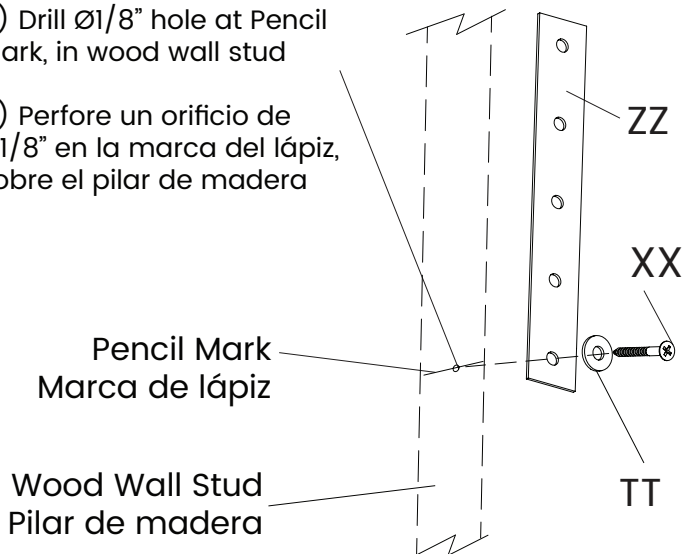

6) Attach the Tip-over restraint strap (ZZ) to the wall using (1) Long Screw (XX) and (1) washer (TT) as shown. The Screw MUST be installed into a wood wall stud (See WARNINGS for additional information).

6) Fije la correa de retención contra volcamiento (ZZ) a la pared utilizando (1) tornillo largo (XX) y (1) arandela (TT), como se indica. El tornillo DEBE instalarse en un pilar de madera (para obtener más información consulte las ADVERTENCIAS).

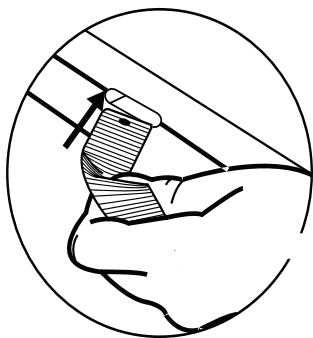

NOTE: Be sure to attach any accessory items to case before completing this step.

7) Feed the Tipover Restraint through the hole as you place the dresser in it's final position.

NOTA: Asegúrese de fijar todos los accesorios a la carcasa antes de completar este paso.

7) Pase el elemento de retención a través del orificio, a medida que posiciona el mueble en su posición final.

8) Pull the Tip-over restraint through the hole and fasten it securely to the case using (1) 15mm Screw (YY) and (1) washer (TT).

8) Pase el elemento de retención a través del orificio y fíjelo con seguridad a la carcasa utilizando (1) tornillo de 15 mm (YY) y (1) arandela (TT).

Attach to Top
Fijar a la parte superior

Attach to Bottom
Fijar al fondo

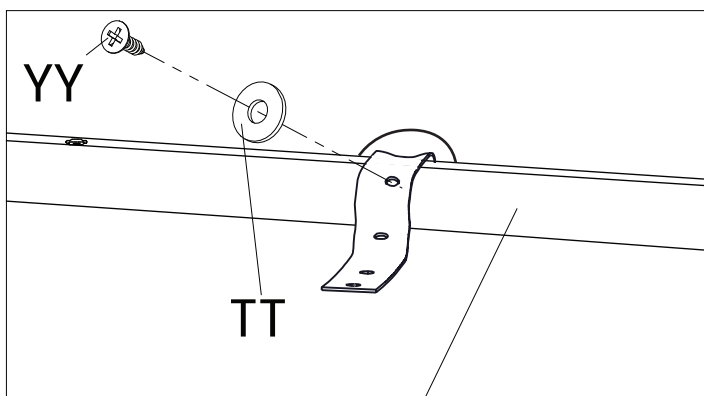
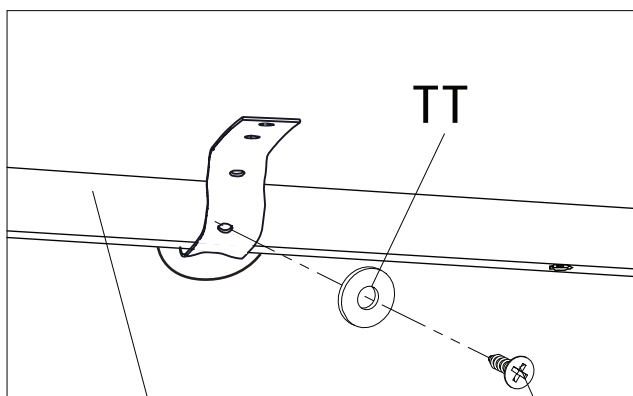

Top Back Rail
Barra Trasero Superior

Bottom Back Rail
BarraTraseroInferior

9) Pull case AWAY from wall until Restraint is SNUG.
9) Jale la carcasa ALEJÁNDOLA de la pared hasta que la retención esté TENSA.

10) Ensure restraint is not loose.
10) Asegúrese de que la retención no esté suelta.

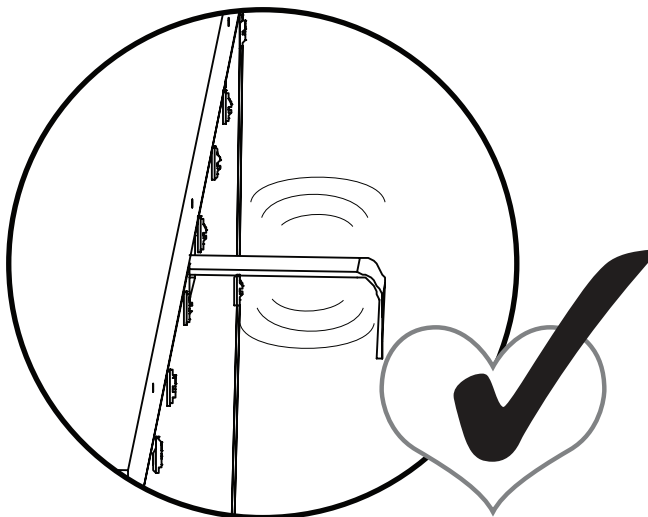
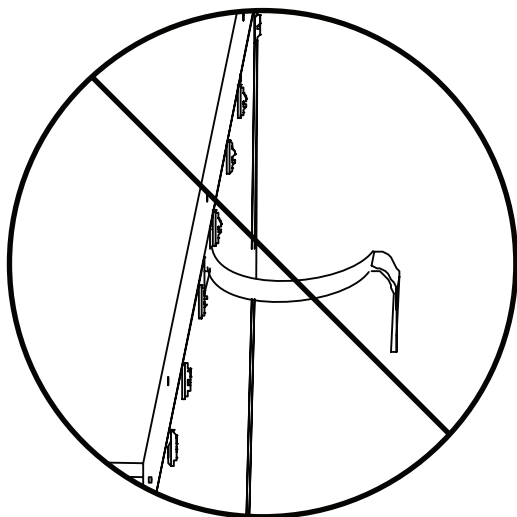

STEP 14

PASO 14

Parts and tools required to complete step

Piezas y herramientas necesarias para completar este paso

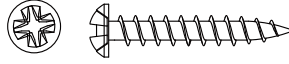

25mm Screw x12
Tornillo 25mm

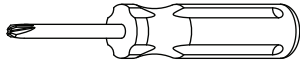

Phillips Screwdriver – Not included
Destornillador Phillips – no incluido

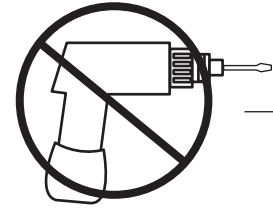

No drills necessary.
Do not use power screwdriver.

No hace falta taladrar.
No utilice destornilladores eléctricos

Slide Bottom Drawer Bottom (Part P) into the grooves. Attach the Drawer Sides (Parts M) to the Drawer Front (Part Q) with (4) 25mm Screws (Part HH). Note: Grooves in Bottom must align. Tighten With Phillips Screwdriver. Repeat this step until (3) drawers are complete.

Deslice la parte inferior de la gaveta inferior (Pieza P) hacia las ranuras. Fije los Barra de la gaveta (Pieza M) a la parte frontal de la gaveta (Pieza Q) utilizando (4) tornillos 25mm (Pieza HH). Nota: Las ranuras al inferior deben alinearse. Apriete utilizando un destornillador Phillips. Repitaestepaso hasta haber completado las 3 gavetas .

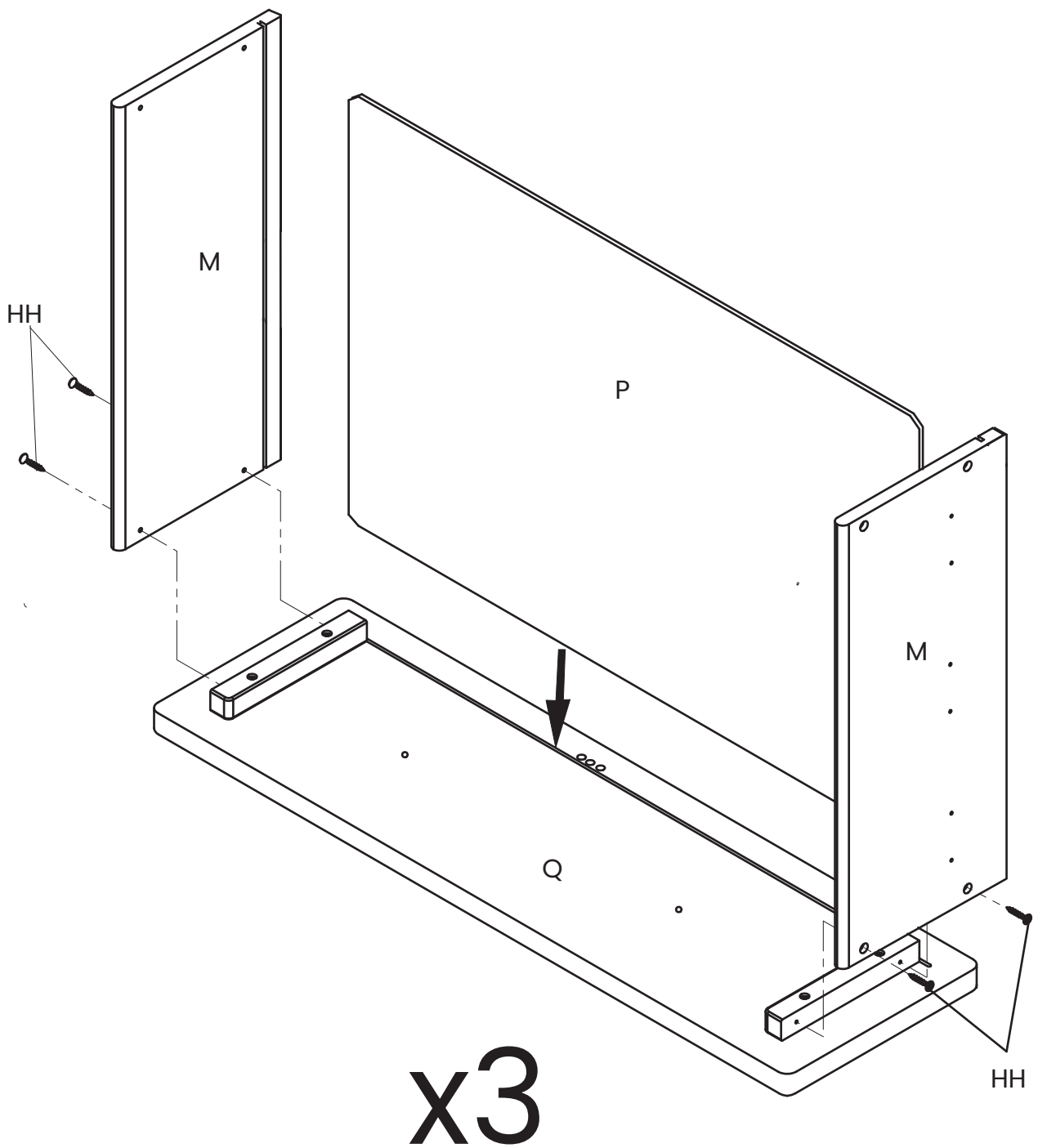

STEP 15
PASO 15

Parts and tools required to complete step
Piezas y herramientas necesarias para completar este paso

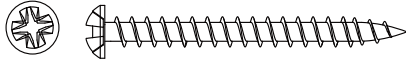

JJ 40mm Screw x15
Tornillo 40mm

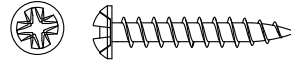

HH 25mm Screw x3
Tornillo 25mm

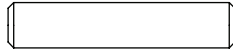

KK M6 x 30mm Wood Dowel x6
Pasador de Madera M6 x 30mm

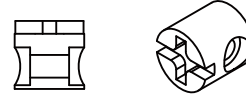

GG Plastic Barrel Nut x15
Tuerca de Barril Plásticas

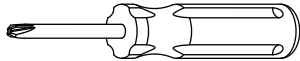

Phillips Screwdriver – Not included
Destornillidor Phillips – no incluido

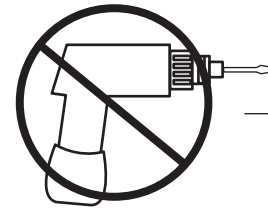

No drills necessary.
Do not use power screwdriver.

No hace falta taladrar.
No utilice destornilladores eléctricos

Install the Drawer Support (Part N) into drawer front using (2) M6 Dowels (Part KK). Attach Drawer Back (Part L) using (5) 40mm Screws (Part JJ) and (5) Plastic Barrel Nuts (Part GG), ensure the grooves at the bottom line up. Attach Drawer Support (Part N) to the Drawer Front using (1) 25mm Screw (Part HH). Tighten With Phillips Screwdriver. Repeat this step until all 3 drawers are complete.

Instalar el soporte de la gaveta (pieza N) dentro de la gaveta utilizando (2) pasadores M6 (pieza KK). Fijar la parte posterior de la gaveta (pieza L) utilizando (5) tornillos de 40mm (pieza JJ) y (5) tuercas plásticas de barril (pieza GG). Asegurarse de que las ranuras en el fondo estén alineadas. Fijar el soporte de la gaveta (pieza N) con el frente de la gaveta utilizando (1) tornillo de 25mm (pieza HH). Apriete utilizando un destornillador Phillips. Repetir este paso hasta que todas las gavetas estén terminadas.

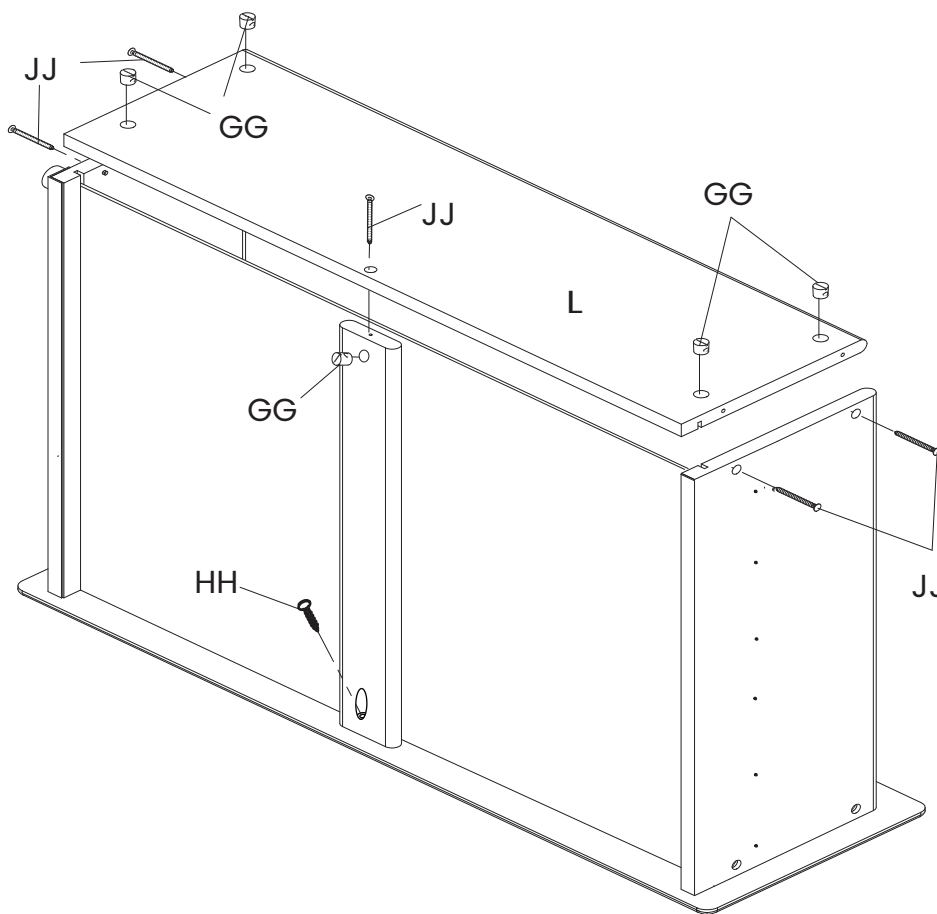
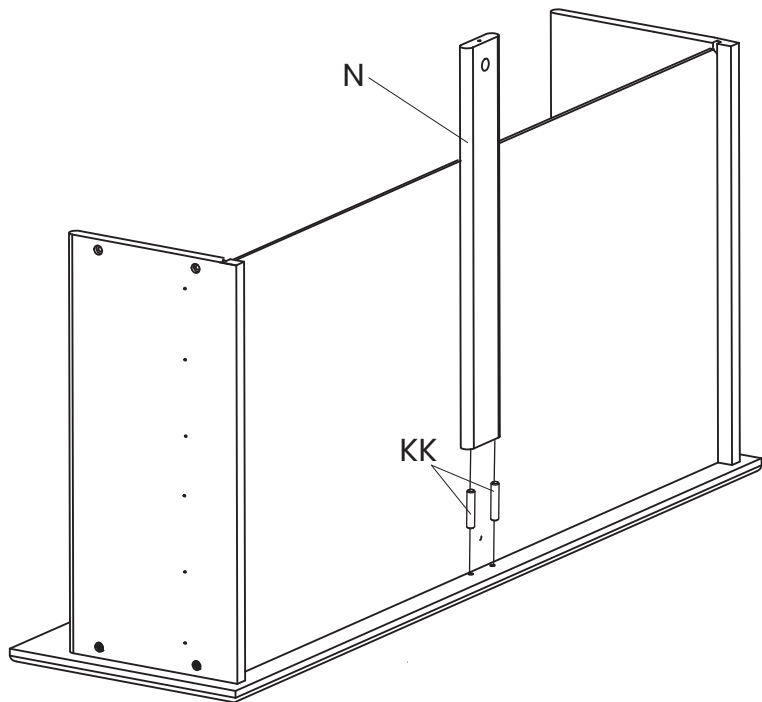

x3

STEP 16
PASO 16

Parts and tools required to complete step
Piezas y herramientas necesarias para completar este paso

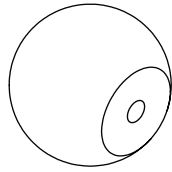

MM1 Knob x6
Perilla



MM2 Knob Screw x6
Tornillo para Perilla

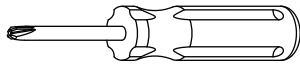

Phillips Screwdriver – Not included
Destornillidor Phillips – no incluido

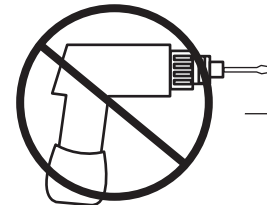

No drills necessary.
Do not use power screwdriver.

No hace falta taladrar.
No utilice destornilladores eléctricos

Attach (2) Knobs (Part MM1) to Drawer Assembly using (2) Knob Screws (Part MM2). Repeat this step until all 3 drawers are complete.

Fije (2) perillas (Pieza MM1) al ensamblaje de la gaveta utilizando (2) Tornillo para Perilla (Pieza MM2). Repita este paso hasta haber completado las 3 gavetas.

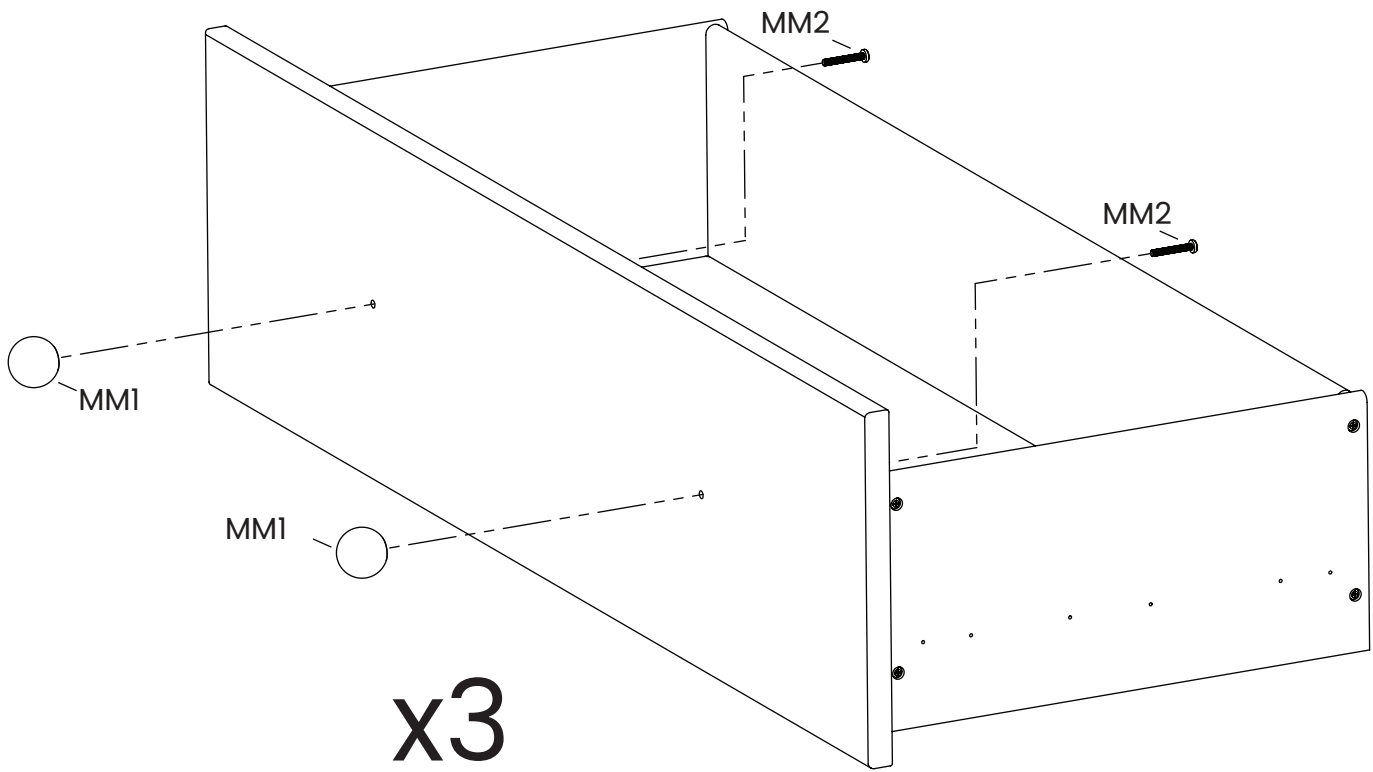

STEP 17
PASO 17

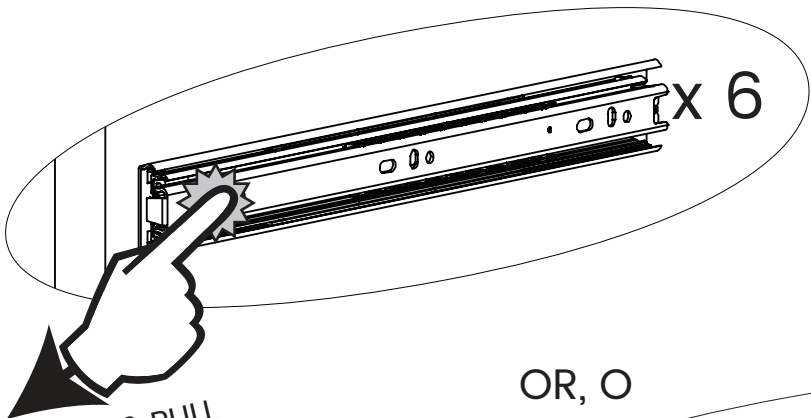
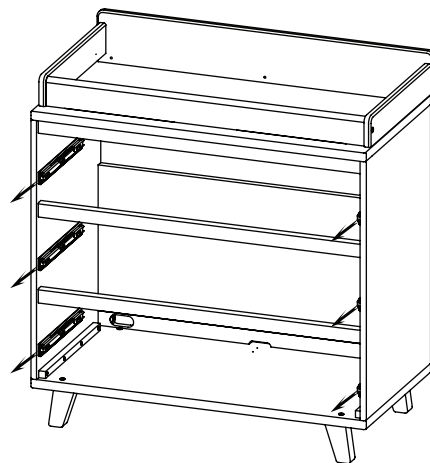

1

Press & PULL
Empujar & SAQUE

OR, O

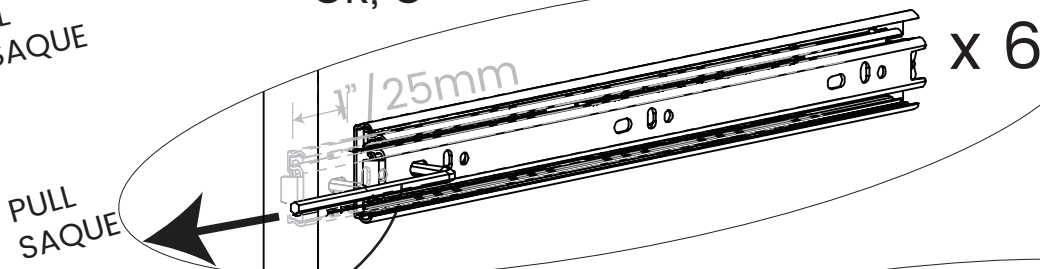

PULL
SAQUE

Allen Wrench
Llave Allen

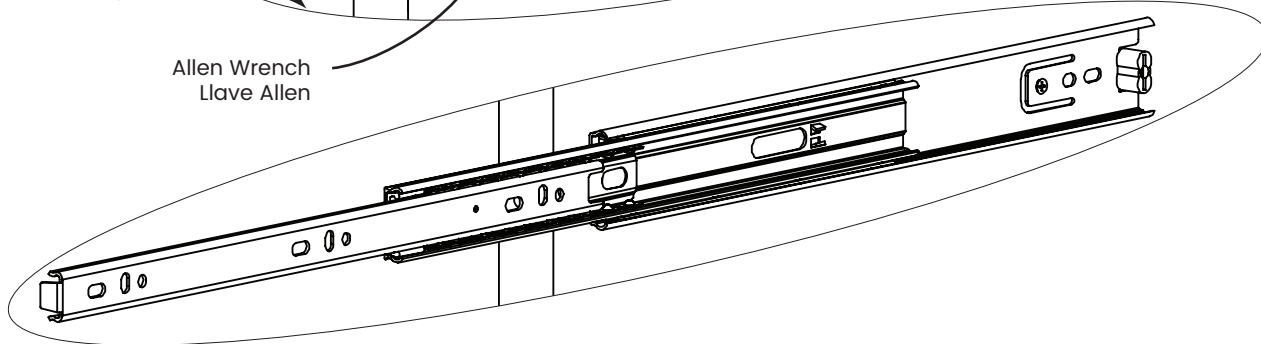

Left/Izquierdo

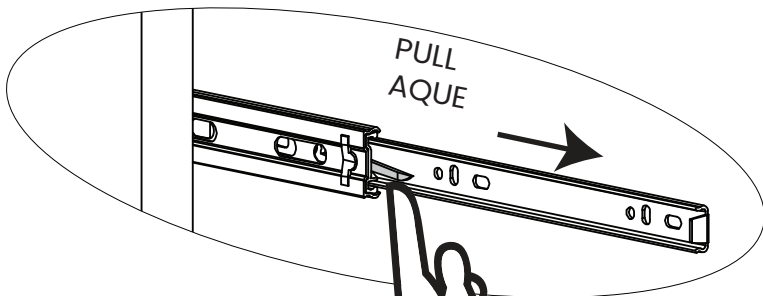

Lift lever on left glide up
izquierda se desliza
hacia arriba

Press lever on right glide down
Empujar la palanca a la dere-
cha se desliza por

2

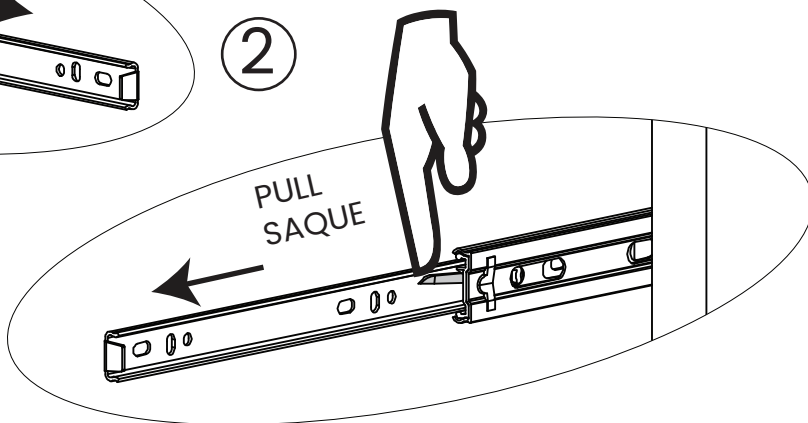

Right/Derecho

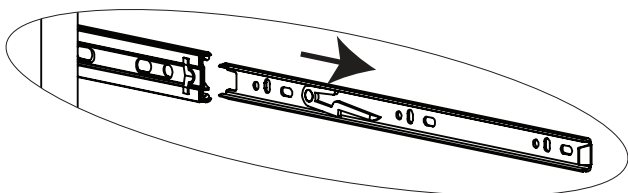

3

The silver portion of the glide must be pulled to the front of the glide when assembling the drawer into the case.

La parte plateada de la guía de la gaveta debe estar al frente de la guía cuando se está armando la cómoda.

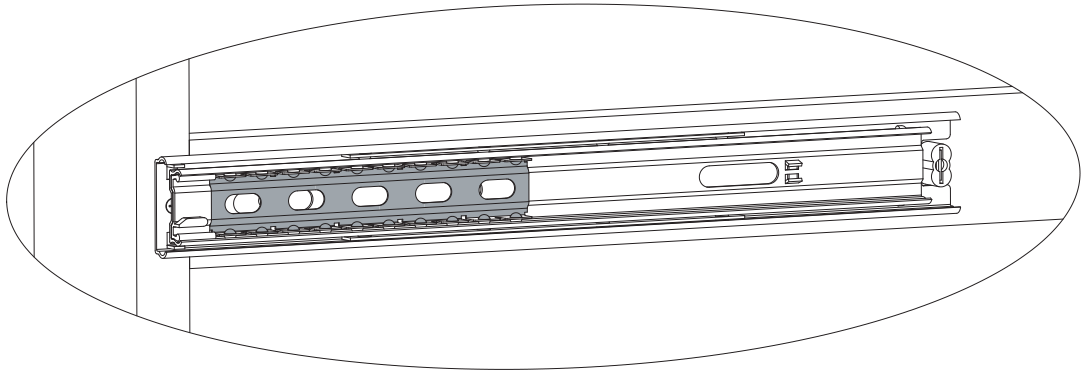
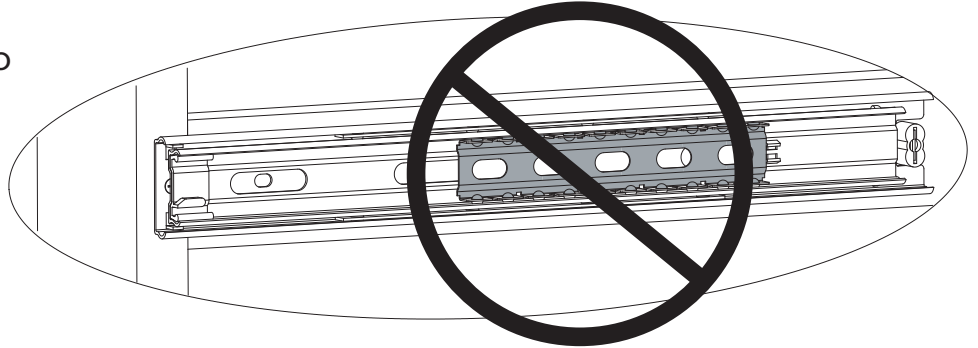
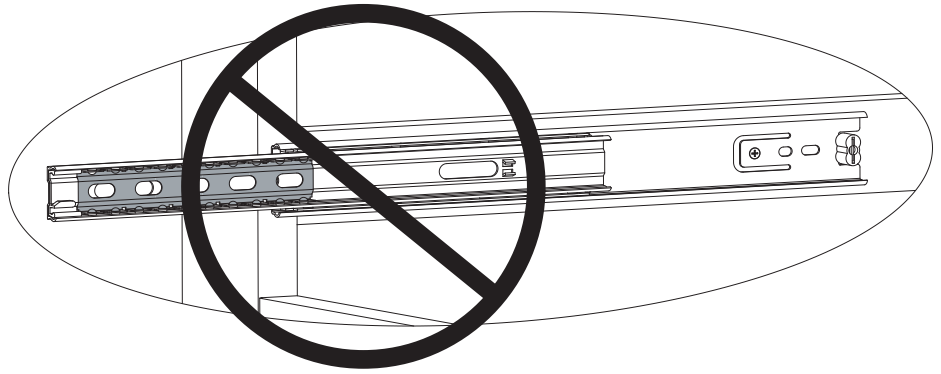

To insert drawer align male runner on drawer to female runner on case and push all the way in.

Para insertar la gaveta alinear runner mujer en la gaveta para de hombre runner case y empuje hasta el fondo.

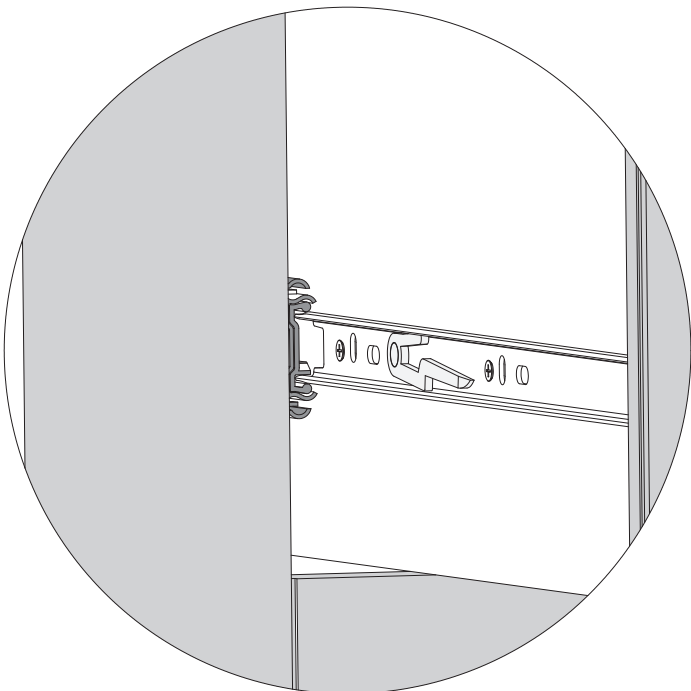

STEP 18

PASO 18

Parts and tools required to complete step

Piezas y herramientas necesarias para completar este paso

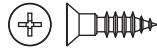

12mm Screw x18
Tornillo 12mm

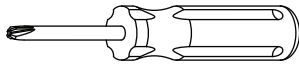

Phillips Screwdriver – Not included
Destornillador Phillips – no incluido

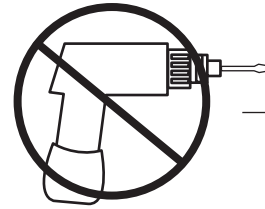

No drills necessary.
Do not use power screwdriver.

No hace falta taladrar.
No utilice destornilladores eléctricos

Attach (2) Drawer Guide outer pieces to each assembled drawer. There are pre-drilled holes in each drawer side.

- i) Place the end of the Drawer Guide with the tab against the Drawer front, then align the holes in the Guide to the holes in the Side, tab should remain very close to the Drawer Front.
- ii) Attach the Drawer Guide with (3) screws (Part AA). Install the screws from the back to the front (1st,2nd,3rd in the illustration). Tighten with a Phillips Screwdriver.
- iii) repeat with the other Drawer Side.
- iv) Repeat until all (3) Drawers are complete.

Fije (2) piezas externas de guía de gaveta en cada gaveta ensamblada. Hay agujeros pre taladrados en cada costado de la gaveta.

- i) Coloque el extremo de la guía de gaveta, con la lengüeta contra la parte frontal de la gaveta, luego alinee la guía con los agujeros del costado; la lengüeta debe quedar muy cerca de la parte frontal de la gaveta.
- ii) Fije la guía de gaveta con (3) tornillos (Pieza AA). Instale los tornillos desde la parte posterior hacia el frente (1st,2nd,3rd en la ilustración). Apriete con un destornillador Philips.
- iii) Repita con el otro costado de la gaveta.
- iv) Repita hasta completar las (3) gavetas

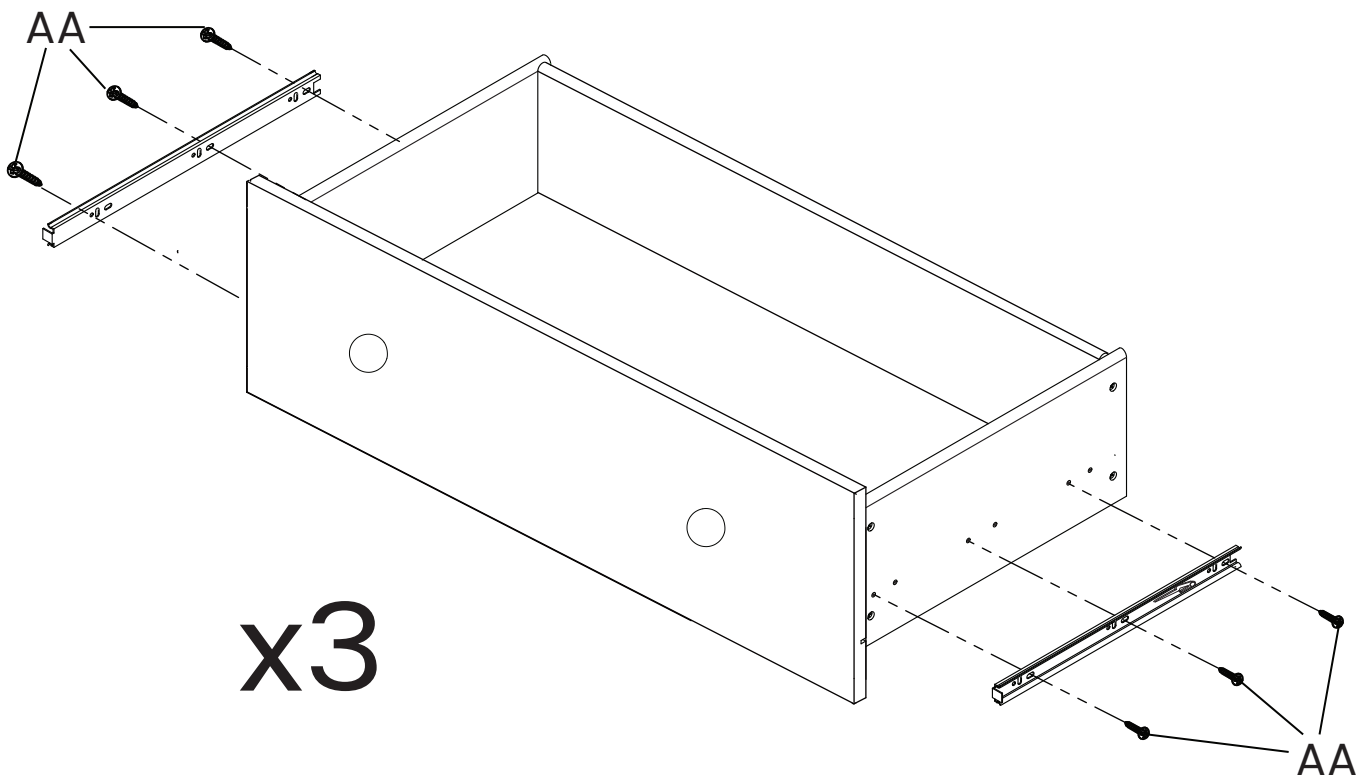
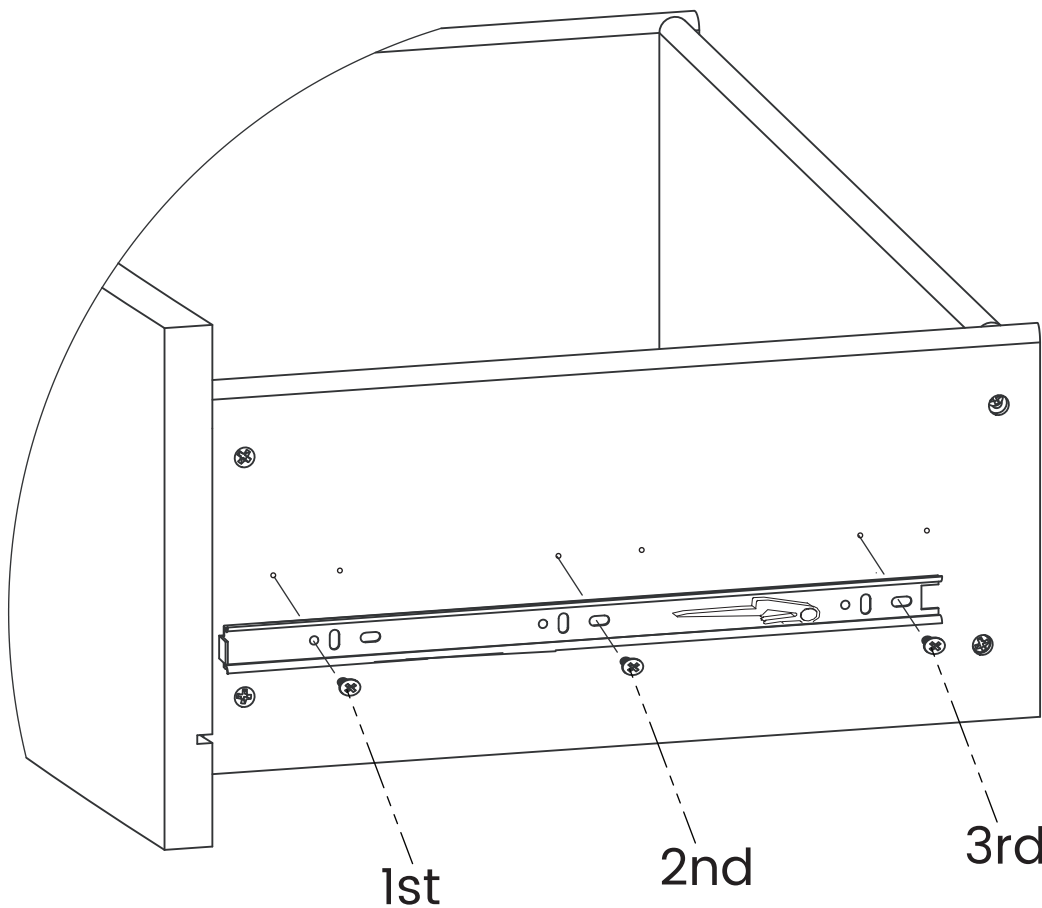

STEP 19
PASO 19

Install the drawers in the case body. Carefully align the Drawer Guides on each drawer with the Drawer Guides on the case. Push the drawer STRAIGHT in until it "clicks". Check that each side is fully secure. Open and close the drawer to ensure smooth operation. Changing the locations may improve fit or performance.

Instale las gavetas en el cuerpo del mueble. Alinee cuidadosamente las guías de gaveta en cada una de ellas con las guías del cuerpo del mueble. Presione la gaveta EN LÍNEA RECTA hasta que haga "clic". Revise que cada lado esté bien asegurado. Abra y cierre la gaveta para asegurarse de que funciona correctamente. Cambiar las ubicaciones podría mejorar el funcionamiento.

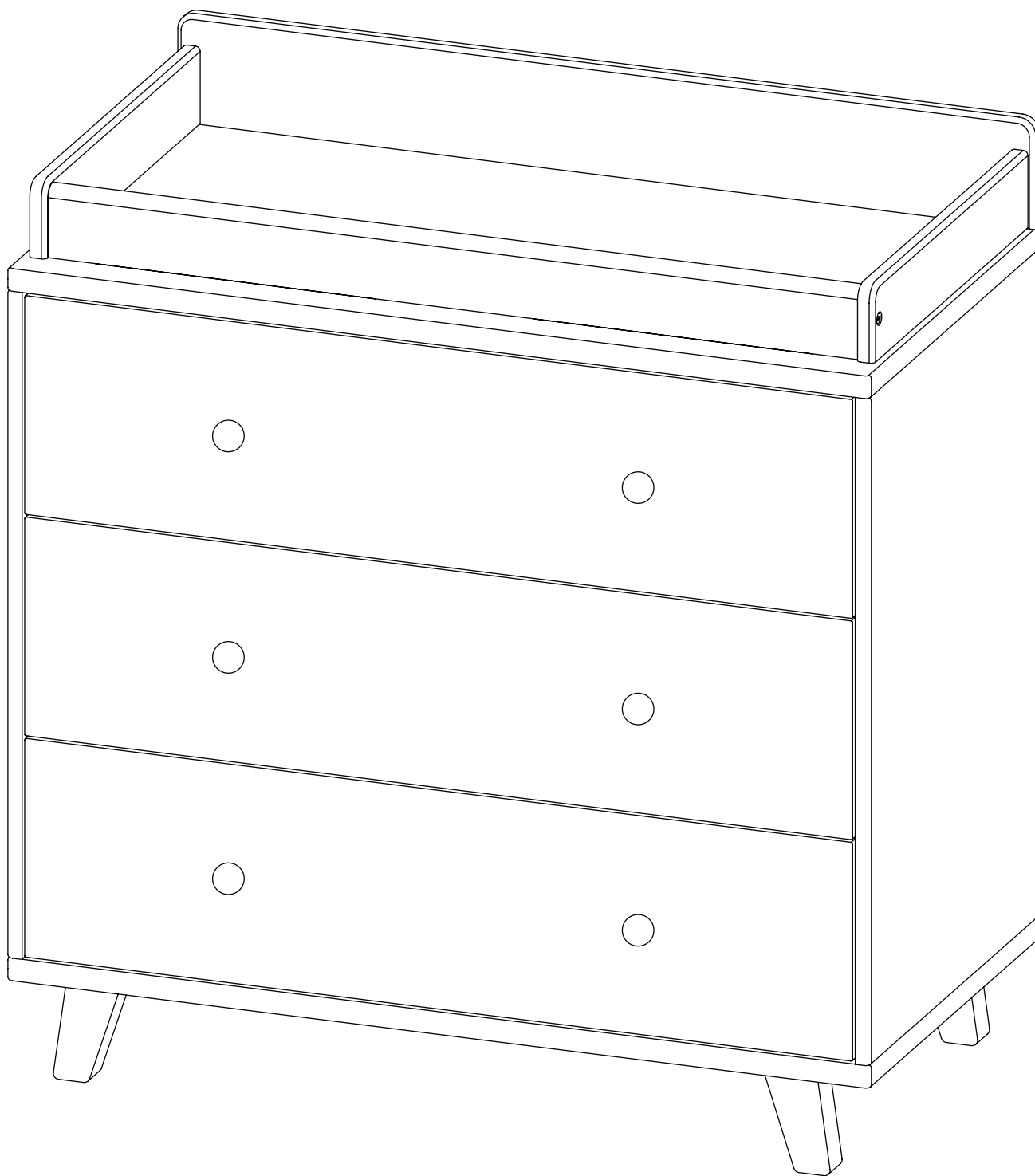

Limited Warranty:

This Delta Product is warranted to be free from defects for a period of 90 days from the date of purchase under normal use. If a product is defective during this period, we will at our option repair or replace the defective part or product. This limited warranty extends only to the original retail purchaser and is valid only when supplied with proof of purchase, or if received as a gift, when the registration is on file with Delta. This limited warranty does not cover the following:

- Products purchased as floor models or samples.
- Items purchased on an “as-is” basis, as a second hand product, or as a resale product.
- Items purchased at a Final sale, a “Going out of Business” sale or a Liquidation sale.

This limited warranty gives you specific legal rights and you may also have other rights which vary from state to state.

To register your product

for important safety alerts and updates to your product please visit
www.deltachildren.com

To report a problem

please log on to www.deltachildren.com/help

Date of Purchase: _____ (you should also keep your receipt)

Garantía Limitada:

Este Producto Delta está garantizado de estar libre de defectos por un período de 90 días a partir de su adquisición, bajo uso normal. Si un producto tiene defectos durante este período, Nosotros tomaremos la opción de reparar o reemplazar la pieza defectuosa del producto. Esta garantía limitada se otorga únicamente al comprador original y es válida solamente cuando se proporciona una prueba de compra, o si el producto fue recibido como un regalo, debe haber sido registrado con Delta. Esta garantía limitada del fabricante no cubre lo siguiente:

- Productos comprados como exhibiciones de la tienda o muestras.
- Artículos comprados como “tal como está”, productos de segunda mano o reventa de los productos.
- Artículos comprados como “venta final”, “ventas de tiendas que están quebrando” o ventas por liquidación.

Esta garantía limitada le otorga derechos legales específicos y también puede tener otros derechos que varían de un estado a otro.

Para registrar su producto

para alertas importantes de seguridad y estar al tanto sobre novedades de su producto por favor visite
www.DeltaChildren.com

Para reportar cualquier problema

por favor entre a www.DeltaChildren.com/help

Fecha de Compra: _____ (debe además mantener su recibo)

SAFETY LEADERS

Visit Deltachildren.Com/Pages/Leaders-In-Safety for more information

SAFE MATERIALS

Safe products start with safe materials. We test all of our products to create the safest and healthiest environment for your baby.



PRODUCTS YOU CAN TRUST

We have 8 cutting edge safety labs around the world where we test our products above and beyond the industry standards. All of our dressers are engineered to meet or exceed ASTM Furniture Safety Standards.



WE GO ABOVE & BEYOND

To protect your children, Delta Children dressers are tested to meet the requirements of the industry tip over test set forth by ASTM. For additional security, we strongly recommend that all dressers in you home be anchored; all Delta Children dressers include a wall anchor.



LÍDERES EN LA SEGURIDAD

Visite Deltachildren.Com/Pages/Leaders-In-Safety para más información

MATERIALES SEGUROS

Los productos seguros se hacen con materiales seguros. Ponemos a prueba todos nuestros productos para crear el ambiente más seguro y saludable para su bebé.



PRODUCTOS CONFIABLES

Tenemos 8 laboratorios de seguridad de alta tecnología donde probamos nuestros productos mas allá de los estándares de la industria. Todos nuestros tocadores están diseñados para cumplir o exceder los estándares de seguridad ASTM de muebles.



ESTAMOS POR ENCIMA Y MÁS ALLÁ

Para proteger a sus niños, los tocadores de Delta Children son sometidos a pruebas para que cumplan los requisitos ASTM establecidos de la industria en cuanto a volcamientos se refiere.

Para seguridad adicional, recomendamos enfáticamente que todos los tocadores de su casa estén fijos: todos los tocadores de Delta Children incluyen un anclaje de pared.



POR QUÉ ELEGIR A DELTA CHILDREN?

Visita Deltachildren.Com/Pages/Our-Story para más información

<p>DELTA LIDERA 1 de cada 2 niños en los EE.UU duerme en nuestros productos</p>	<p>DELTA DONA 10% de nuestros ingresos está destinado a mejorar la vida de los niños</p>	<p>A DELTA LE IMPORTA Hacemos pruebas por encima de los estándares de seguridad de la industria</p>	<p>DELTA ESTÁ DEDICADA Nuestra empresa familiar ha estado siempre presente para su familia desde 1968</p>	<p>DELTA CRECE CON USTEDES Tenemos productos para cada edad y etapa</p>	<p>Más De 50 Años De Seguridad, Estilo E Innovación</p>
--	---	--	--	--	--

Bienvenido a la **FAMILIA DELTA**
Aquí Está Nuestro Regalo Para Usted

10% OFF

Su Próxima Compra En DeltaChildren.com

UTILICE EL CÓDIGO:
DELTA10

PRODUCTOS PARA CADA EDAD Y ETAPA

 CUNAS	 COSAS PARA BEBÉ	 SILLA	 MOISÉS	 COLCHÓN	
 CARRILLAS	 CAMA PARA NIÑO	 CUARTO DE JUGAR	 CAMA SENCILLA	 CONTENEDORES	 TOCADORES

NUESTRA FAMILIA DE LAS MEJORES MARCAS



MÁS DE 50 AÑOS DE SEGURIDAD, ESTILO E INNOVACIÓN

WHY CHOOSE DELTA CHILDREN?

Visit Deltachildren.Com/Pages/Our-Story for more information

<p>DELTA LEADS 1 Out Of 2 Children In The U.S. Sleep In Our Products</p>	<p>DELTA GIVES 10% Of Our Profits Go Toward Improving The Lives Of Children</p>	<p>DELTA CARES We Test Above & Beyond Industry Safety Standards</p>	<p>DELTA IS DEDICATED Our Family-Run Company Has Been There For Your Family Since 1968</p>	<p>DELTA GROWS WITH YOU We Have Products For Every Age And Stage</p>	<p>Over 50 Years Of Safety, Style & Innovation</p>
---	--	--	---	---	---

Welcome to the **DELTA FAMILY**
Here's a Gift From Us To You





10% OFF

Your Next Purchase From DeltaChildren.com

USE CODE: DELTA10

*Exclusions Apply
*Subject to Change

PRODUCTS FOR EVERY AGE AND STAGE

					
CRIBS LITS POUR BÉBÉ CUNAS	STROLLERS ÉQUIPEMENT POUR BÉBÉ COSAS PARA BEBÉ	GLIDERS CHAISE SILLA	BASSINETS COUFFINS MOISÉS	MATRESSES MATELAS COLCHÓN	
					
BABY GEAR POUSSETTES CARRIOLAS	TODDLER BEDS LITS POUR ENFANT CAMA PARA NIÑO	PLAYROOM FURNITURE SALLE DE JEUX CUARTO DE JUGAR	TWIN BEDS LITS UNE PLACE CAMA SENCILLA	BINS & ORGANIZERS PANIERES CONTENEDORES	DRESSERS COMMODOES TOCADORES

OUR FAMILY OF TOP BRANDS



OVER 50 YEARS OF SAFETY, STYLE, AND INNOVATION