



Read all instructions before assembly and use.
KEEP INSTRUCTIONS FOR FUTURE USE.

Lisez toutes les instructions avant l'assemblage et l'utilisation.
CONSERVEZ LES INSTRUCTIONS POUR UN USAGE ULTERIEUR.

Lea todas las instrucciones antes de ensamblar y usar.
MANTENGA LAS INSTRUCCIONES PARA SU USO FUTURO.



Dresser With Changing Top
Commode avec plan à langer
Cómoda con el cambiador

Style #: _____
 Lot: _____
REV Date: _____

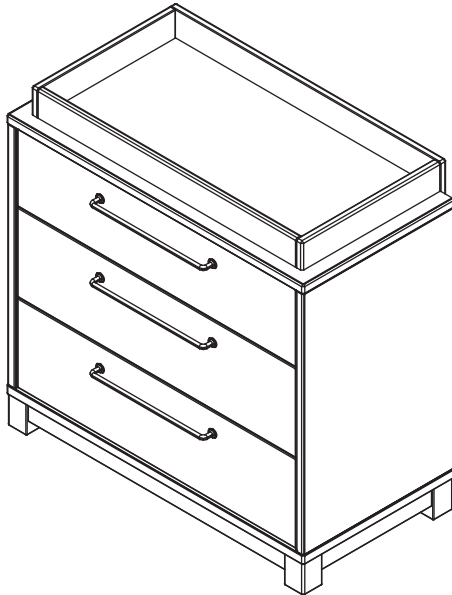

⚠ ADULT ASSEMBLY REQUIRED

Due to the presence of small parts during assembly, keep out of reach of children until assembly is complete.

⚠ L'ASSEMBLAGE DOIT ETRE FAIT PAR UN ADULTE

A cause de la presence de petites pieces, pendant l'assemblage gardez hors de portee des enfants jusqu'a ce que celui-ci soit termine.

⚠ DEBE SER ENSAMBLADO POR UN ADULTO

Debido a la presencia de piezas pequeñas durante el ensamblaje, mantenga fuera del alcance de los niños hasta que complete el ensamblaje.

**This product is not intended for institutional or commercial use.
Ce produit ne pas destine a un usage institutionnel ou commercial.
Este producto no esta hecho para uso institucional o comercial.**

NEED EXTRA HELP?

We make assembly easy with our tips & tricks video

<https://www.deltachildren.com/pages/instructions>

BESOIN D'AIDE SUPPLÉMENTAIRE?

Nous facilitons l'assemblage avec nos trucs et astuces vidéo

<https://www.deltachildren.com/pages/instructions>

¿NECESITA AYUDA EXTRA?

Hacemos el montaje fácil con nuestros consejos y trucos video

<https://www.deltachildren.com/pages/instructions>

When contacting Delta Consumer Experience Center please reference the above information. Before contacting Delta Consumer Experience Center please ensure that the information above matches the information found on the label on the *Back Panel*, please reference the information found on the product when contacting Delta Consumer Experience Center.

Lorsque vous contactez le Service client de Delta, veuillez faire référence aux informations ci-dessus. Avant de contacter le Service client de Delta, veuillez vous assurer que les informations ci-dessus correspondent aux informations indiquées sur l'étiquette qui se trouve sur *panneau arrière*; veuillez faire référence aux informations indiquées sur le produit lorsque vous contactez le Service client de Delta.

Al contactar al servicio al cliente de Delta, entregue la información anteriormente mencionada. Antes de contactar al servicio de atención al cliente de Delta, asegúrese de que la información anteriormente mencionada calza con la que aparece en la etiqueta en *panel trasero*; al contactar al centro de atención al cliente de Delta, mencione la información que aparece en el producto.

CONSUMER EXPERIENCE CENTER

Simmons Juvenile Furniture, A division of Children's Products LLC | 114 West 26th Street New York, NY 10001



BABY SAFE SLEEP TIPS

Visit Deltachildren.Com/Pages/Crib-Safety-Tips for more information



Read all warnings and follow all instructions.



DO NOT place any items in the crib.



The safest place for your baby to sleep is in a JPMA Certified crib.



Pillows and blankets have caused infants to suffocate, **NEVER** use in a crib.

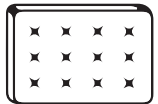

Your baby should sleep on a firm mattress.



NEVER place the crib near a window or any wall hangings.



Adult beds are not safe for babies: **NEVER** co-sleep.



Missing or broken parts, any questions? **CALL** Delta Children Consumer Care.



AAP Recommends: Always lay your baby on its back to sleep. Consult your doctor.





FURNITURE SAFETY TIPS

Visit Deltachildren.Com/Pages/Leaders-In-Safety for more information

SERIOUS OR FATAL CRUSHING INJURIES CAN OCCUR FROM FURNITURE TIP-OVER.



Read all warnings and follow all instructions.



NEVER open more than one drawer at a time.



ALWAYS use provided tipover restraints.



DO NOT leave drawers open when not in use.



DO NOT set TV's or other heavy objects on the top of bedroom or nursery furniture.



NEVER allow children to climb or hang on drawers, doors, or shelves.



Place heaviest items in the lowest drawers.



Missing or broken parts, any questions? **CALL** Delta Children Consumer Care.



CONSEILS POUR FAIRE DORMIR VOTRE BÉBÉ EN TOUTE SÉCURITÉ

Visitez Deltachildren.Com/Pages/Crib-Safety-Tips pour plus d'information



Lisez tous les avertissements et respectez toutes les consignes de sécurité.



NE déposez aucun objet dans le Lit de Bébé



L'endroit le plus sûr pour faire dormir votre bébé, c'est dans un Lit de Bébé approuvé par JPMA.



Des oreillers et couvertures ont parfois été responsables d'étouffements de nourrissons. **N'**en utilisez **JAMAIS** dans un lit de bébé.

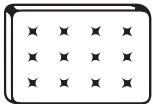

Votre bébé doit dormir sur un matelas ferme.



NE placez **JAMAIS** le Lit de Bébé à proximité d'une fenêtre ou de tentures.



Les lits d'adultes ne sont pas un lieu sûr pour les bébés: **NE** dormez **JAMAIS** ensemble.



Des pièces manquantes ou cassées? **APPELEZ** Delta Children Consumer Care.



Conseils de l'AAP: Placez toujours votre bébé sur le dos pour dormir. Consultez votre médecin.





CONSEILS DE SÉCURITÉ RELATIFS AUX MEUBLES

Visitez Deltachildren.Com/Pages/Leaders-In-Safety pour plus d'information

LE RENVERSEMENT DU MEUBLE PEUT ENTRAÎNER DES BLESSURES GRAVES OU MORTELLES.



Lisez tous les avertissements et respectez toutes les consignes de sécurité.



N'OUVREZ JAMAIS plus d'un tiroir en même temps



Utilisez **TOUJOURS** les dispositifs de non-renversement fournis.



NE laissez **PAS** les tiroirs ouverts lorsque vous ne les utilisez pas.



NE déposez **PAS** de postes de télévision ou d'autres objets lourds sur des meubles de chambre à coucher ou de chambre d'enfants.



NE laissez **JAMAIS** les enfants monter sur ou se suspendre aux tiroirs, portes et ou tablettes.



Placez les objets les plus lourds dans les tiroirs du bas.



Des pièces manquantes ou cassées? **APPELEZ** Delta Children Consumer Care.



CONSEJOS PARA UN SUEÑO SEGURO PARA LOS BEBÉS

Visite Deltachildren.Com/Pages/Crib-Safety-Tips para obtener más información



Lea todas las advertencias y siga todas las instrucciones.



NO coloque artículos en la cuna.



El lugar más seguro para que su bebé duerma es una cuna con certificación JPMA.



Las almohadas y frazadas han provocado asfixia en menores; por lo tanto, **JAMÁS** se deben utilizar en una cuna.



Su bebé debe dormir sobre un colchón firme.



NEVER place the crib near a window or any wall hangings.



Las camas para adultos no son seguras para los bebés: **JAMÁS** duerma con ellos.



¿Le faltan piezas o vienen rotas? **LLAME** al Delta Children Consumer Care.



APP recomienda: Haga que su bebé duerma siempre boca arriba. Consulte a su médico.





CONSEJOS DE SEGURIDAD SOBRE MUEBLES

Visite Deltachildren.Com/Pages/Leaders-In-Safety para obtener más información

**PUEDEN PRODUCIRSE LESIONES GRAVES O MORTALES POR
APLASTAMIENTO AL VOLCARSE MUEBLES.**



Lea todas las advertencias y siga todas las instrucciones.



NUNCA abra más de un cajón al mismo tiempo.



Utilice **SIEMPRE** las retenciones contra volcamiento incluidas



NO DEJE cajones abiertos si no los está utilizando.



NO posicione televisores u otros objetos pesados sobre la cama o muebles para infantes.



NUNCA permita que los niños trepen sobre cajones, puertas o baldas de estantería ni que se cuelguen de ellos.



Coloque los artículos de mayor peso en los cajones inferiores.



¿Le faltan piezas o vienen rotas? **LLAME** al Delta Children Consumer Care.



SAVE BIG WITH DELTA CHILDREN

Visit **Deltachildren.com** To Start Shopping

Welcome to the
DELTA FAMILY
Here's a Gift From Us To You

10% OFF

Your Next Purchase From
DeltaChildren.com

**USE CODE:
DELTA10**

*Exclusions Apply
*Subject to Change

REVIEW TO WIN \$2500

RULES TO ENTER

★ ★ ★ ★ ★

"We LOVE, LOVE, LOVE this crib"

My husband was impressed with the directions and organization of the hardware package. He easily assembled this crib in an hour without any help. It's very sturdy and we like that it has adjustable levels for the mattress height. To top it all off, it's so incredibly darling!!!

- 1 WRITE A REVIEW** for this product on the store's website from where it was purchased
- 2 TAKE A SCREENSHOT** of your review and upload it to www.DeltaChildren.com/Review
- 3 IT'S THAT EASY!** Upon submission, you'll be instantly **ENTERED TO WIN \$2,500**

FOLLOW US FOR MORE CHANCES TO WIN

@deltachildren

SCAN HERE



For more information & to see all of our products





ÉCONOMISEZ BEAUCOUP AVEC AHORRE MUCHO CON DELTA CHILDREN

Visitez **Deltachilren.com** Pour Commencer Vos Achats
Visita **Deltachilren.com** Para Comenzar A Comprar

Bienvenue dans la
FAMILIE DELTA
Voici Notre Cadeau Pour Vous
Bienvenido a la
FAMILIA DELTA
Aquí Está Nuestro Regalo Para Usted

10% OFF

Votre Prochain Achat Chez
Su Próxima Compra En
DeltaChildren.com

UTILISEZ LE CODE:
UTILICE EL CÓDIGO:
DELTA10

*Des exclusions s'appliquent
*Sujet à changement

*Exclusions Apply
*Subject to Change

LAISSEZ UN COMMENTAIRE CLIENT POUR **GAGNER \$2500**
CALIFIQUE EL PRODUCTO PARA **GANAR \$2500**

REGLEMENT DE PARTICIPATION / REGLAS PARA PARTICIPAR

- 1** **ECRIVEZ UN COMMENTAIRE CLIENT** pour ce produit sur le site web du magasin où il a été acheté
CALIFIQUE EL PRODUCTO en la página web de la tienda donde haya sido comprado
- 2** **FAITES UNE CAPTURE D'ECRAN** de votre commentaire client et mettez la en ligne sur www.DeltaChildren.com/Review
HAGA UNA CAPTURA DE PANTALLA de su calificación y cárguela a la pagina www.DeltaChildren.com/Review
- 3** **C'EST AUSSI SIMPLE QUE ÇA!** Dès que c'est fait vous serez instantanément **INSCRIT POUR GAGNER 2500\$**
ES ASÍ DE FÁCIL! En cuanto lo envíe ya estará instantáneamente **PARTICIPANDO PARA GANAR \$2.500**

SUIVEZ NOUS POUR AVOIR PLUS DE CHANCES DE GAGNER /
SÍGANOS PARA TENER MAS CHANCES DE GANAR



@deltachildren

SCANNEZ ICI / ESCANEE AQUÍ



Pour plus d'informations et
pour voir tous nos produits

Para más información y para
ver todos nuestros productos



⚠ WARNING



Children have died from furniture tipover. To reduce the risk of furniture tipover:

- ALWAYS install tipover restraint provided.
- NEVER put a TV on this product.
- NEVER allow children to stand, climb or hang on drawers, doors, or shelves.
- NEVER open more than one drawer at a time.
- Place heaviest items in the lowest drawers.



⚠ AVERTISSEMENT



Des enfants sont morts à cause d'un meuble qui se renverse. Pour aider à prévenir un renversement :

- Installez TOUJOURS le système anti-bascule fourni.
- Ne JAMAIS placer un téléviseur sur ce produit.
- Ne jamais permettre à un enfant de grimper ou s'accrocher aux tiroirs, portes ou étagères.
- Ne jamais ouvrir plus d'un tiroir à la fois
- Placez les articles les plus lourds dans les tiroirs inférieurs.



⚠ ADVERTENCIA



Han muerto niños debido a volcaduras de muebles. Para prevenir volcaduras:

- Instalar SIEMPRE el dispositivo anti-volcaduras incluido.
- No colocar NUNCA un televisor en este producto.
- Nunca permita que los niños trepen sobre cajones, puertas o baldas de estantería ni que se cuelguen de ellos.
- Nunca abra más de un cajón al mismo tiempo.
- Coloque los artículos de mayor peso en los cajones inferiores.



NOTES ON ASSEMBLY:

-During the assembly process whenever using screws or bolts, check each by placing the screw/bolt on the diagram of the item which is drawn actual size and design. Be sure to use the proper size and shape specified in the instructions.

-To assemble this unit you may be required to place the unit on it's side and face. It is strongly recommended that assembly is done on a soft, non-abrasive surface to avoid damaging the finish.

NOTES ON CARE AND MAINTENANCE:

- **Do not** scratch or chip the finish.

- Inspect the product periodically, contact Delta Children's Products for replacement parts or questions.

- **Do not** store the product or any parts in extreme temperatures and conditions such as a hot attic or a damp, cold basement. These extremes can cause a loss of structural integrity.

-To preserve the luster of the high quality finish on your product, it is recommended to place a doily or felt pad under any items you place on the finish.

-Clean with a damp cloth, then a dry cloth to preserve the original luster and beauty of this fine finish.

-**Do not** use abrasive chemicals.

-**Do not** spray cleaners directly onto furniture.

-Lift slightly when moving on carpeting to prevent leg breakage.

-Use of a vaporizer near furniture will cause wood to swell and finish to peel.

REMARQUES SUR L'ASSEMBLAGE :

-Lors de l'assemblage, quand vous utilisez vis ou boulons, vérifiez chaque pièce en plaçant le vis/boulon sur le diagramme de la pièce concernée qui est dessinée en taille et forme réelle. Assurez-vous d'utiliser la taille et la forme exacte comme il est spécifié dans les instructions.

-Pour assembler cet élément vous pourriez avoir besoin de le placer sur le côté latéral et sur le côté frontal. Il est fortement recommandé de faire l'assemblage sur une surface lisse, non abrasive (comme le film mousse de l'emballage) pour éviter d'endommager les finitions.

REMARQUES SUR LE SOIN ET L'ENTRETIEN:

-**Ne pas** rayer ou ébrécher la finition.

-Examinez de près le produit régulièrement, contactez Delta Children's Products pour les pièces de rechange ou pour poser des questions.

-**Ne pas** ranger le produit ou des pièces à des températures extrêmes ou dans des conditions comme un grenier chaud ou une cave froide et humide. Ces extrêmes peuvent causer une perte de l'intégrité de la structure du produit

-Pour préserver le lustre original et la beauté de ce fini raffiné nettoyer avec un chiffon humide, puis un chiffon sec.

-**Ne pas** utiliser des produits chimiques abrasifs

-**Ne pas** pulvériser un nettoyant directement sur le meuble, pulvériser sur le torchon et puis appliquer sur le meuble. Testez le produit nettoyant sur un endroit discret avant de l'utiliser sur la totalité du meuble

-Lors d'un déplacement sur une moquette ou tapis, soulevez légèrement le meuble pour éviter de casser les pieds.

-L'utilisation d'un vaporisateur près du meuble causera le gonflement du bois et l'écaillage de la finition.

INFORMACIÓN SOBRE EL MONTAJE:

-Durante el proceso de montaje, ya utilice pernos o tornillos, compruebe cada uno de ellos colocando el perno/tornillo en el diagrama del artículo donde está dibujado el tamaño y el diseño real. Asegúrese de que utiliza el tamaño y la forma adecuada que especifican las instrucciones.

-Para montar esta unidad, puede que se le solicite que coloque la unidad de lado y de cara. Se recomienda encarecidamente que realice el montaje sobre una superficie no abrasiva (Como la envoltura de embalaje de espuma) para evitar dañar el acabado.

NOTAS SOBRE SU CUIDADO Y MANTENIMIENTO:

- **No** arañe ni desconche el acabado.

- Inspeccione el producto con regularidad, póngase en contacto con Delta Children's Products para el recambio de partes o para formular preguntas.

- **No** guarde el producto ni ninguna de sus partes a temperaturas ni en condiciones extremas como un ático caluroso o un sótano húmedo y frío. Estos extremos pueden provocar una pérdida de integridad estructural.

-Para preservar el brillo del acabado de alta calidad que recubre su producto, se recomienda que coloque un paño o una almohadilla de fieltro debajo de cualquier objeto que coloque sobre el acabado.

-Límpielo con un trapo húmedo y luego con uno seco para preservar el brillo y la belleza originales de este fino acabado.

-**No** utilice productos químicos abrasivos.

-**No** pulverice limpiadores directamente sobre el mueble.

-Élévelo ligeramente cuando lo mueva sobre alfombras o moqueta para evitar que se rompan las patas.

-El uso de vaporizadores cerca de muebles puede provocar que la madera se hinche y acabe desconchándose.



PARTS: MAKE SURE THAT ALL PRE-ASSEMBLED PARTS ARE TIGHT
 PIÈCES : VÉRIFIEZ QUE TOUTES LES PIÈCES PRÉ-MONTÉES SONT BIEN SERRÉES.
 PIEZAS: ASEGÚRESE DE QUE TODAS LAS PIEZAS PRE-ENSAMBLADAS ESTÁN BIEN APRETADAS.

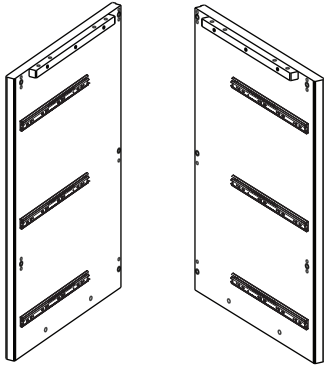

A. Left Side x1
Côté gauche
Lado izquierdo
40604

B. Right Side x1
Côté droit
Lado derecho
40605

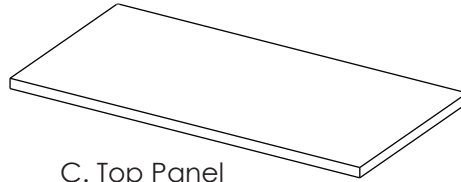

C. Top Panel
Panneau supérieur
Panel superior
40606

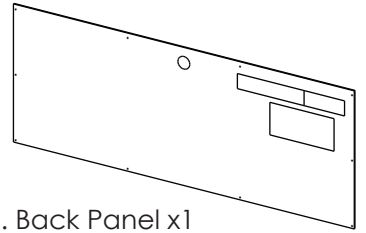

D. Back Panel x1
Panneau arrière
Panel trasero
40612

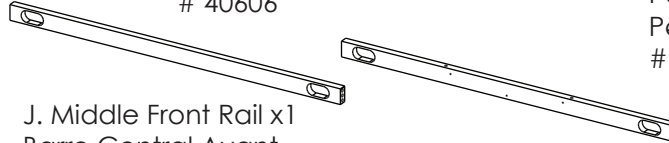

J. Middle Front Rail x1
Barre Central Avant
Barra Frontal Central
40609

F. Top Back Rail x1
Barre arrière supérieur
Barra trasero superior
40610

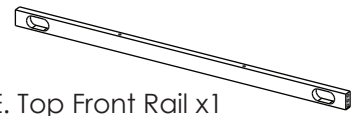

E. Top Front Rail x1
Barre avant supérieur
Barra frontal superior
40608

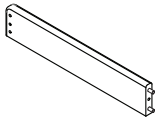

U. Changing Top Left Side x1
Côté gauche du plan à langer
Lado izquierdo del cambiador
40623

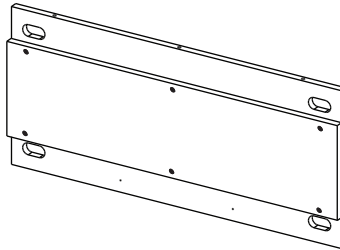

H. Bottom Back Rail x1
Barre arrière inférieur
Barra trasero inferior
40611

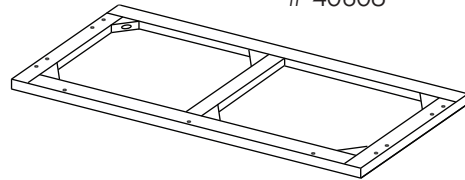

Y. Bottom Panel
Panneau inférieur
Panel inferior
40607

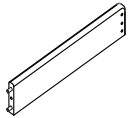

W. Changing Top Right side x1
Côté droit du plan à langer
Lado derecho del cambiador
40624

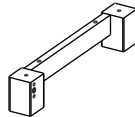

N. Left Base Side x1
Côté Gauche du Base
Lado Izquierdo de la Base
#40613

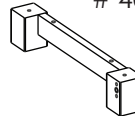

M. Right Base Side x1
Côté Droite du Base
Lado Derecho de la Base
40614

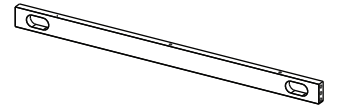

G. Bottom Front Rail x1
Barre avant inférieur
Barra frontal inferior
40615

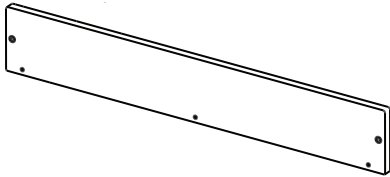

S. Changing Top Back x1
Partie postérieure du plan à langer
Parte posterior del cambiador
40621



T. Changing Top Front x1
Partie frontale du plan à langer
Parte frontal del cambiador
40622

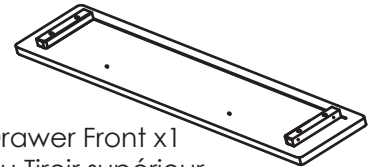

P. Top Drawer Front x1
Avant du Tiroir supérieur
Parte frontal de la Gaveta superior
40616

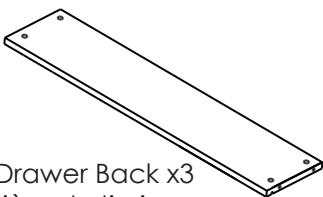

L. Drawer Back x3
Arrière du tiroir
Trasera de la gaveta
40619

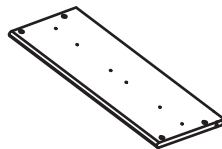

X. Drawer Side x6
Barre de tiroir
Barra de la gaveta
40618

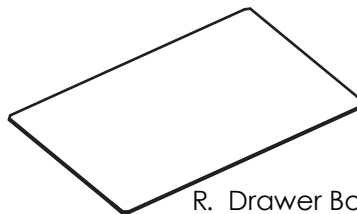

R. Drawer Bottom x3
Fond du tiroir
Fondo de la gaveta
40620

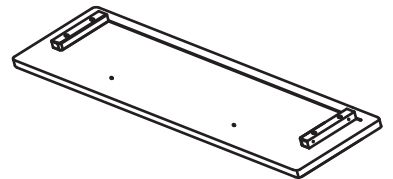

K. Bottom Drawer Front x2
Avant du Tiroir inférieur
Parte frontal de la Gaveta inferior
40617





Parts: Hardware kits part# 40625

Pièces: L'ensemble de quincaillerie - pièce n°40625

Piezas: El kit de herramientas - Pieza #40625

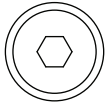

CC. 35mm Bolt x6
Boulon 35mm
Perno 35mm

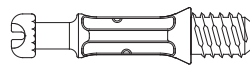

LL. Cam bolt x2
Goujon D'Assemblage Rapide
Perno De Leva

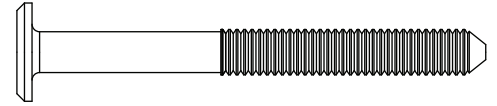
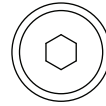

RR. 60mm Bolt x14
Boulon 60mm
Perno 60mm



BB. Crescent Washer x12
Rondelle en croissant
Arandela de media luna

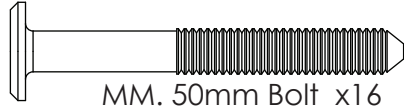
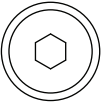

MM. 50mm Bolt x16
Boulon 50mm
Perno 50mm



AA. Cam lock x2
Vis D'Assemblage Rapide
Cerradura de Leva

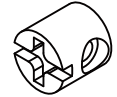

EE. Plastic Barrel Nut x12
Écrou à portée cylindrique
en plastique
Tuercacilíndricaplástica

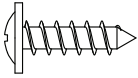

HH. Back Panel Screw x10
Vis pour Panneau Arrière
Tornillo de Panel Trasero



DD. 10x15mm Barrel Nut x7
Écrou à portée cylindrique 10x15mm
Tuerca cilíndrica 10x15mm

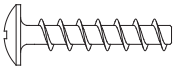

GG. 20mm Screw x12
Vis 20mm
Tornillo 20mm

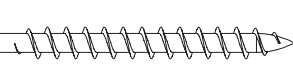

FF. 40mm Screw x15
Vis 40mm
Tornillo 40mm

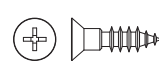

NN. 12mm Screw x18
Vis 12mm
Tornillo 12mm

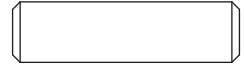

KK. Φ8x30mm Dowel x32
Cheville Φ8x30mm
Pasador Φ8x30mm

PP. Handle/Tirage/Manija x3
#40603

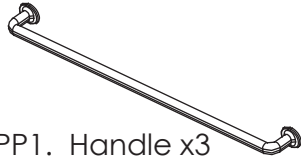

PP1. Handle x3
Tirage
Manija



PP2. Handle Screw x6
Vis de Tirage
Tornillo para Manija

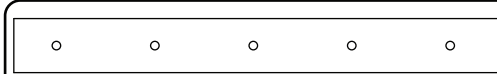

ZZ. Wall Strap x1
Sangle murale
Abrazadera

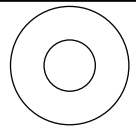

TT. Washer x2
Rondelle
Arandela



XX. Long Screw x1
Vis Longue
Tornillo Largo

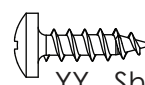

YY. Short Screw x1
Vis Court
Tornillo corto

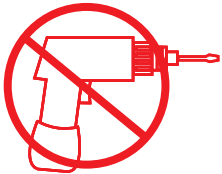

M4 Ballend Screwdriver
tournevis M4 à tête sphérique
destornillador M4 con cabeza de bola

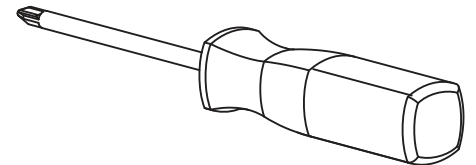
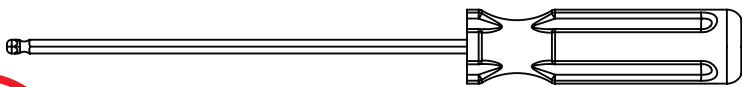

Phillips Screwdriver – Not included
Tournevis Phillips - non inclus
Destornillidor Phillips – no incluido

CAUTION: Do Not use a power screwdriver they can cause screws to break or strip.

ATTENTION: Ne Pas utiliser un tournevis électrique car les vis peuvent casser ou perdre leurs filets.

ATENCIÓN: No use un destornillador eléctrico ya que puede causar que los tornillos se rompan o rueden.

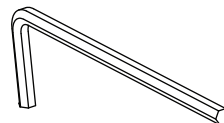

M4 Allen Wrench
Clé Allen M4
Llave Allen M4

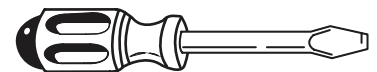

Flat Screwdriver – Not included
tournevis à tête plate - non inclus
destornillador de cabeza plana – no incluido





Hardware System - Review Before Assembly
Quincaillerie – Lire Avant D’effectuer Le Montage
Revise Antes De Armar- Elementos De Fijacion Y Ensamble

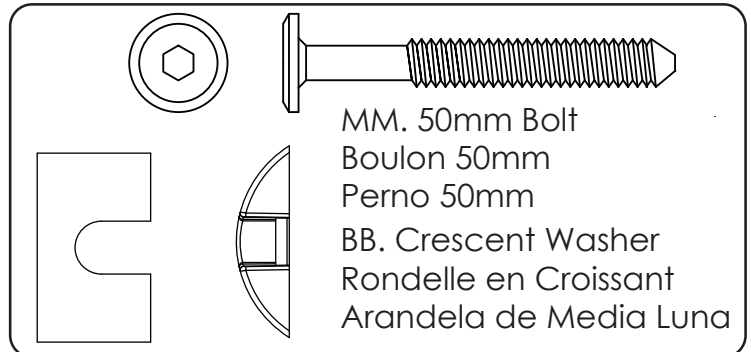
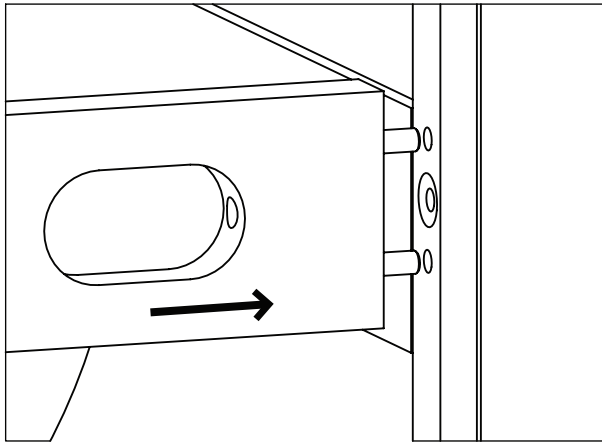

1. Insert the Dowels in the Rail into the holes in the Post.
1. Insérer les chevilles dans le rail dans les orifices dans le poteau.
1. Inserte los pasadores del Riel en los agujeros del Poste.

2. Insert the Bolt into the slot. Turn clockwise with fingers or the Ball End Screwdriver provided. DO NOT fully tighten, leave 1/2" (12mm) exposed.

2. Insérez le boulon dans la fente. Tournez dans le sens des aiguilles d'une montre à l'aide des doigts ou de la tournevis à tête sphérique. Ne Pas serrer complètement et laissez 12 mm (1/2 pouces) exposés.

2. Inserte el perno en la ranura. Gírelo en el sentido de las agujas del reloj con los dedos o con el destornillador con cabeza de bola. NO lo apriete del todo, deje 1/2" (12 mm) fuera.

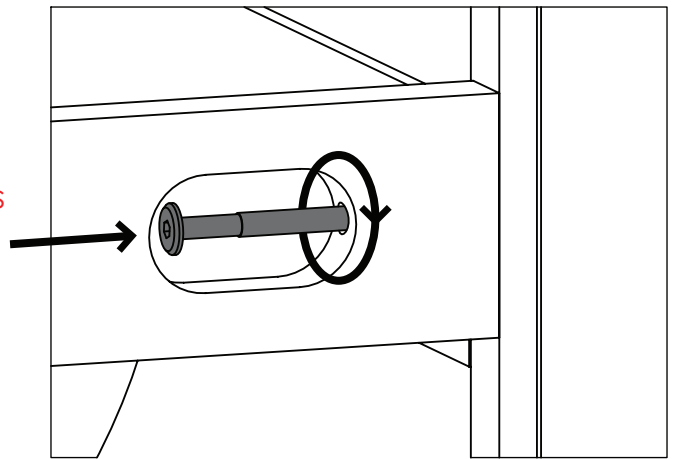

3. Slide the Crescent Washer over the exposed bolt, behind the head of the bolt.

3. Glissez la rondelle en croissant sur l'écrou exposé, derrière la tête de l'écrou.

3. Abrace la parte del Perno que quedó fuera, debajo de la cabeza del mismo, con la Arandela de media luna.

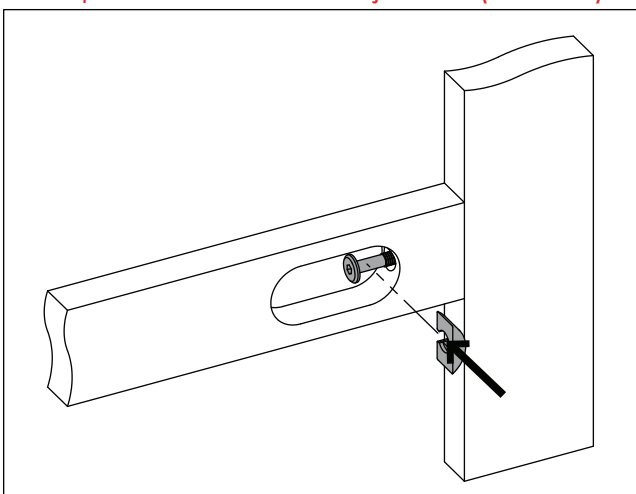



Install (1) bolt and (1) crescent washer at a time. Tighten until it looks like the picture.

Installez (1) boulon et (1) rondelle en croissant à la fois. Serrez jusqu'à ce que cela ressemble à l'image.

Instale (1) perno y (1) Arandela de media luna al mismo tiempo. Apriételos hasta que quede como en la ilustración.

Tighten the bolt with the ball end screwdriver.
Serrez à l'aide de la Tournevis à tête sphérique.
Apriételo con el Destornillador hcon cabeza de bola.

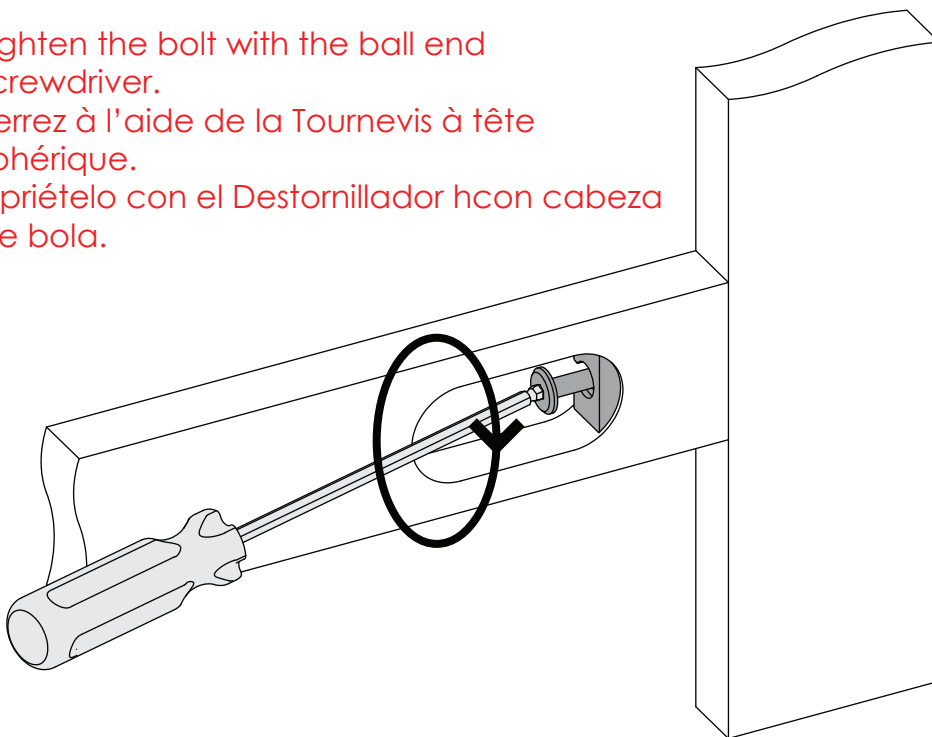

Ensure all bolts are tight with Allen wrench.
Serrez à l'aide de la clé Allen.
Apriételo con la llave Allen.

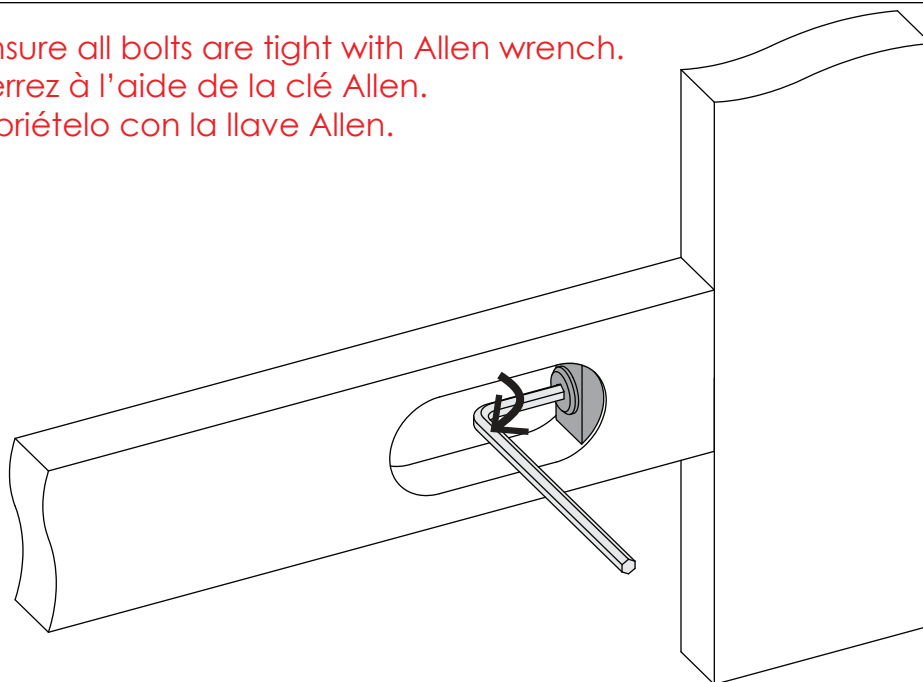



Step 1
Étape 1
Paso 1

Parts and tools required to complete step
Pièces et outils nécessaires au montage
Piezas y herramientas necesarias para completar este paso

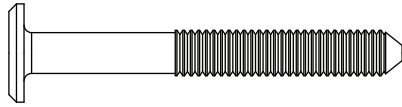
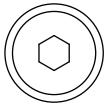

MM. 50mm Bolt x5
Boulon 50mm
Perno 50mm



BB. Crescent Washer x5
Rondelle en croissant
Arandela de media luna



KK. Φ 8x30mm Dowel x8
Cheville Φ 8x30mm
Pasador Φ 8x30mm

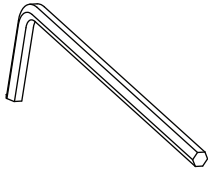

M4 Allen Wrench
Clé Allen M4
Llave Allen M4

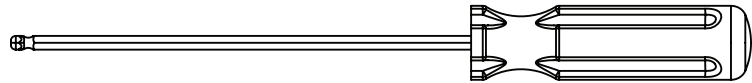

M4 Ballend Screwdriver
tournevis M4 à tête sphérique
destornillador M4 con cabeza de bola

Attach the Bottom Back Rail (Part H), Top Front Rail (Part E), Middle Front Rail (Part J) and Top Back Rail (Part F) to Left Side (Part A) using (5) 50mm bolts (Part MM), (5) Crescent Washer (Part BB) and (8) Dowels (Part KK). Tighten the Bolts with the M4 Ballend Screwdriver and M4 Allen wrench, following the instructions on pages 14 and 15.

Fixer le Barre arrière inférieur (Pièce H), Barre Supérieur avant (Pièce E), Barre Central Avant (Pièce J) et Barre Supérieur Arrière (Pièce F) aux Côté gauche (Pièce A) à l'aide de (5) boulons de 50 mm (Pièce MM), (5) Rondelle en croissant (Pièce BB) et (8) Chevilles (Pièce KK) à l'aide de dutournevis M4 à tête sphériqueet la clé Allen M4 ensuivant les instructions pages 14 et 15.

Fije la Barra trasero inferior (Pieza H), Barra Frontal Superior (Pieza E), Barra Frontal Central (Pieza J) y Barra Posterior Superior (Pieza F) al Lado izquierdo (Pieza A) utilizando (5) Pernos 50mm (Pieza MM), (5) Arandela de media luna (Pieza BB) y (8) Pasadors (Pieza KK) utilizando el destornillador M4 con cabeza de bola y la llave Allen M4 siguiendo las instrucciones de las páginas 14 y 15.



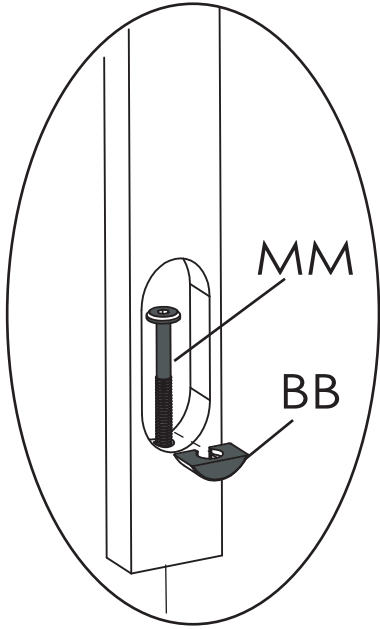

x5

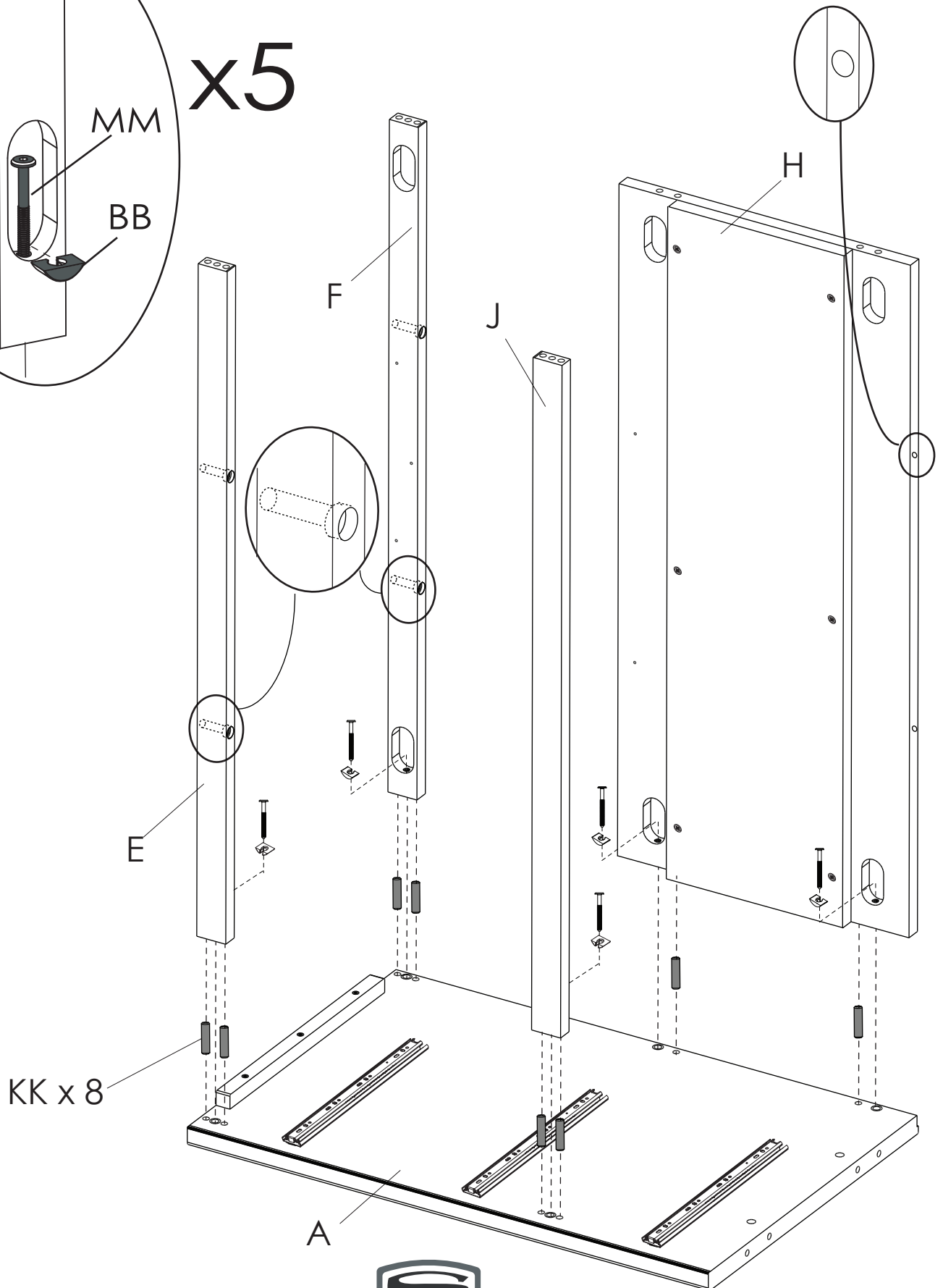



Step 2
Étape 2
Paso 2

Parts and tools required to complete step
Pièces et outils nécessaires au montage
Piezas y herramientas necesarias para completar este paso

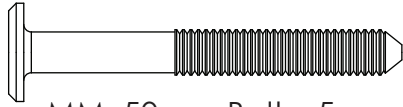

MM. 50mm Bolt x5
Boulon 50mm
Perno 50mm



BB. Crescent Washer x5
Rondelle en croissant
Arandela de media luna



KK. Φ 8x30mm Dowel x8
Cheville Φ 8x30mm
Pasador Φ 8x30mm

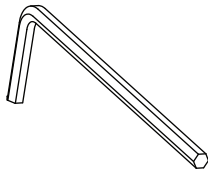

M4 Allen Wrench
Clé Allen M4
Llave Allen M4

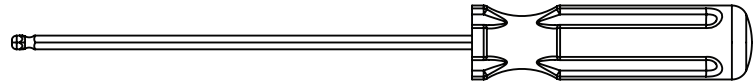

M4 Ballend Screwdriver
tournevis M4 à tête sphérique
destornillador M4 con cabeza de bola

Attach Right Side (Part B) using (5) 50mm bolts (Part MM), (5) Crescent Washer (Part BB) and (8) Dowels (Part KK). Tighten the Bolts with the M4 Ballend Screwdriver and M4 Allen wrench, following the instructions on pages 14 and 15.

Fixer le Côté droit (Pièce B) à l'aide de (5) boulons de 50 mm (Pièce MM), (5) Rondelle en croissant (Pièce BB) et (8) Chevilles (Pièce KK) à l'aide de dutournevis M4 à tête sphérique et la clé Allen M4 ensuivant les instructions pages 14 et 15.

Fije la Lado derecho (Pieza B) utilizando (5) Pernos 50mm (Pieza MM), (5) Arandela de media luna (Pieza BB) y (8) Pasadors (Pieza KK) utilizando el destornillador M4 con cabeza de bola y la llave Allen M4 siguiendo las instrucciones de las páginas 14 y 15.

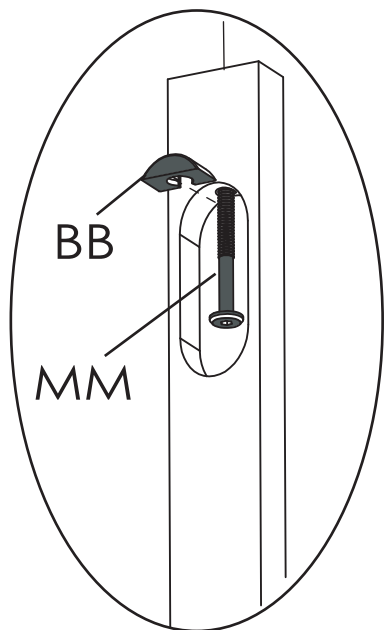

x5

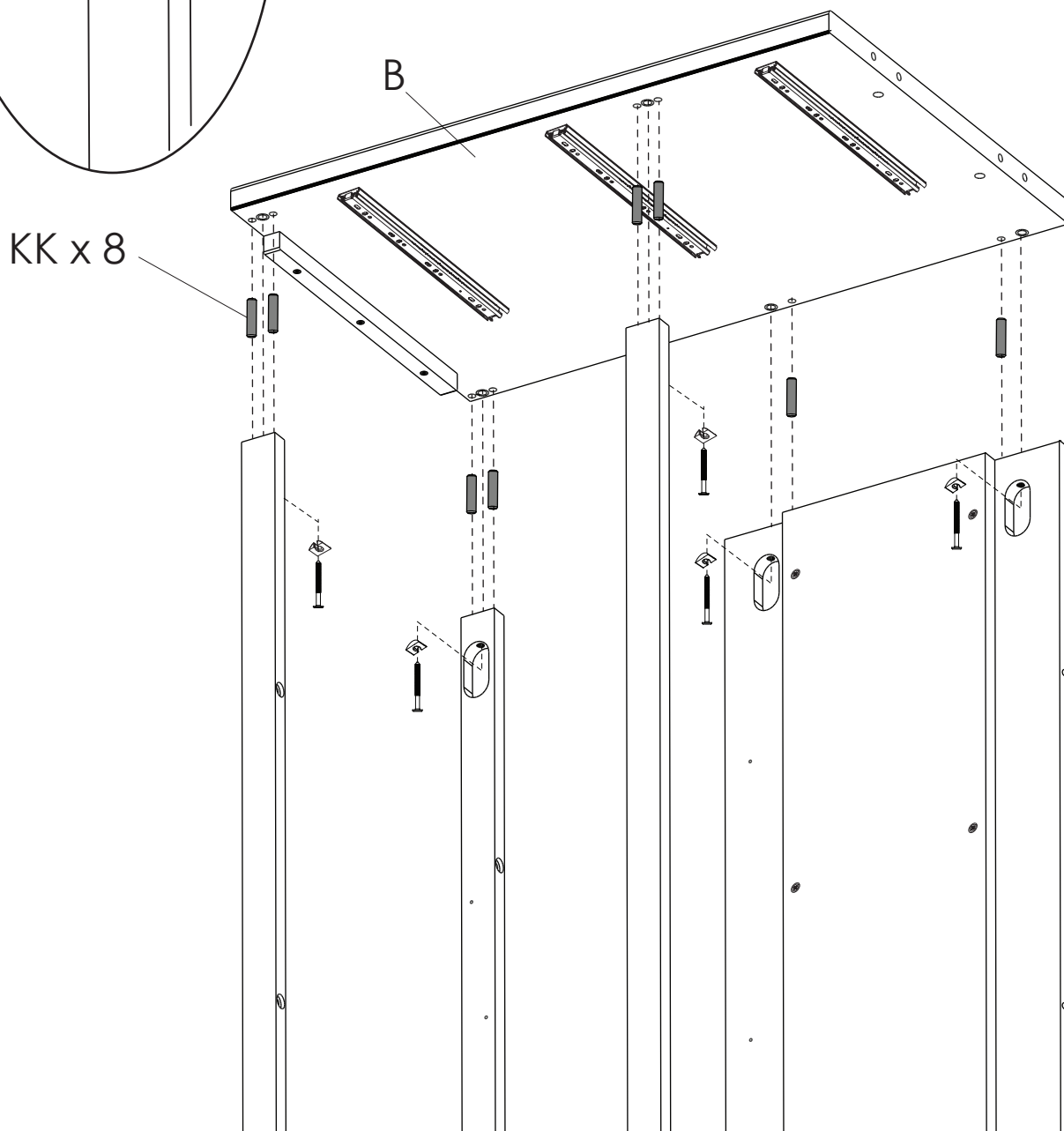



Step 3
Étape 3
Paso 3

Parts and tools required to complete step
Pièces et outils nécessaires au montage
Piezas y herramientas necesarias para completar este paso

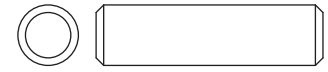

KK. Φ 8x30mm Dowel x4
Cheville Φ 8x30mm
Pasador Φ 8x30mm

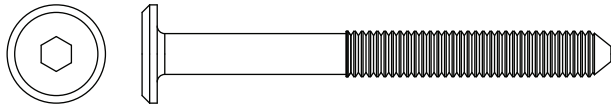

RR. 60mm Bolt x7
Boulon 60mm
Perno 60mm

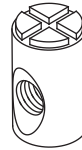

DD. 10x15mm Barrel Nut x 7
Écrou à portée cylindrique 10x15mm
Tuerca cilíndrica 10x15mm

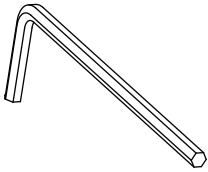

M4 Allen Wrench
Clé Allen M4
Llave Allen M4

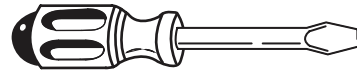

Flat Screwdriver – Not included
tournevis à tête plate - non inclus
destornillador de cabeza plana – no incluido

Attach the Bottom Panel (Part Y) using (4) Dowels (Part KK), (7) 60mm Bolts (Part RR) and (7) Barrel Nuts (Part DD). Tighten with the M4 Allen Wrench. Use the Flat Head Screwdriver to hold the Barrel Nut in the proper alignment.

Fixer le Panneau inférieur (Pièce Y) à l'aide de (4) Chevilles (Pièce KK), (7) boulons de 60 mm (Pièce RR) et (7) Écrou à portée cylindrique (Pièce DD). Serrez à l'aide de la clé hexagonale M4. Utilisez le tournevis à tête plate pour maintenir les écrous à portée cylindrique dans l'alignement approprié.

Fije el Panel inferior (Pieza Y) utilizando (4) Pasadores (Pieza KK), (7) pernos de 60 mm (Pieza RR) y (7) Tuerca cilíndrica (Pieza DD). Apriete todos los pernos utilizando la Llave Allen M4. Utilice el destornillador de cabeza plana para sostener la tuerca de barril en la alineación adecuada.

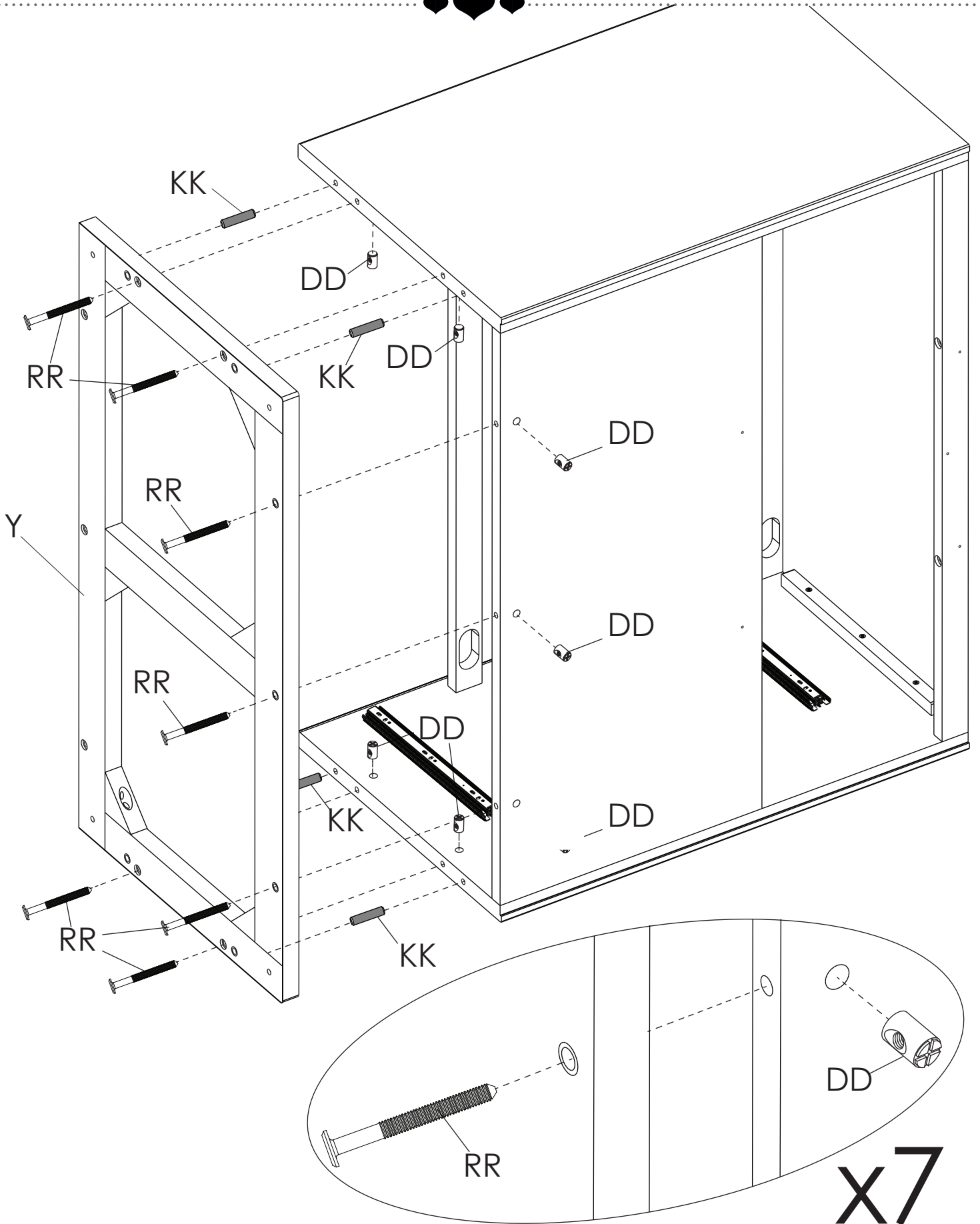



Step 4
Étape 4
Paso 4

Parts and tools required to complete step
Pièces et outils nécessaires au montage
Piezas y herramientas necesarias para completar este paso

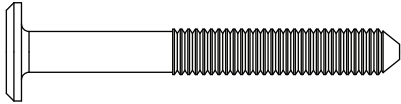
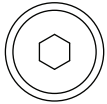

MM. 50mm Bolt x2
Boulon 50mm
Perno 50mm



BB. Crescent Washer x2
Rondelle en croissant
Arandela de media luna



KK. Φ 8x30mm Dowel x4
Cheville Φ 8x30mm
Pasador Φ 8x30mm

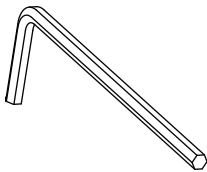

M4 Allen Wrench
Clé Allen M4
Llave Allen M4

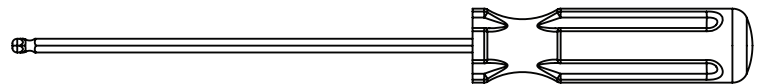

M4 Ballend Screwdriver
tournevis M4 à tête sphérique
destornillador M4 con cabeza de bola

Attach the Left Base Side (Part N) and Right Base Side (Part M) to Bottom Front Rail (Part G) using (2) 50mm bolts (Part MM), (2) Crescent Washer (Part BB) and (4) Dowels (Part KK). Tighten the Bolts with the M4 Ballend Screwdriver and M4 Allen wrench, following the instructions on pages 14 and 15.

Fixer le Côté Gauche du Base (Pièce N) et Côté Droite du Base (Pièce M) aux Barre avant inférieure (Pièce G) à l'aide de (2) boulons de 50 mm (Pièce MM), (2) Rondelle en croissant (Pièce BB) et (4) Chevilles (Pièce KK) à l'aide de dutournevis M4 à tête sphériqueet la clé Allen M4 ensuivant les instructions pages 14 et 15.

Fije la Lado Izquierdo de la Base (Pieza N) y Lado Derecho de la Base (Pieza M) al Barra frontal inferior (Pieza G) utilizando (2) Pernos 50mm (Pieza MM), (2) Arandela de media luna (Pieza BB) y (4) Pasadors (Pieza KK) utilizando el destornillador M4 con cabeza de bola y la llave Allen M4 siguiendo las instrucciones de las páginas 14 y 15.

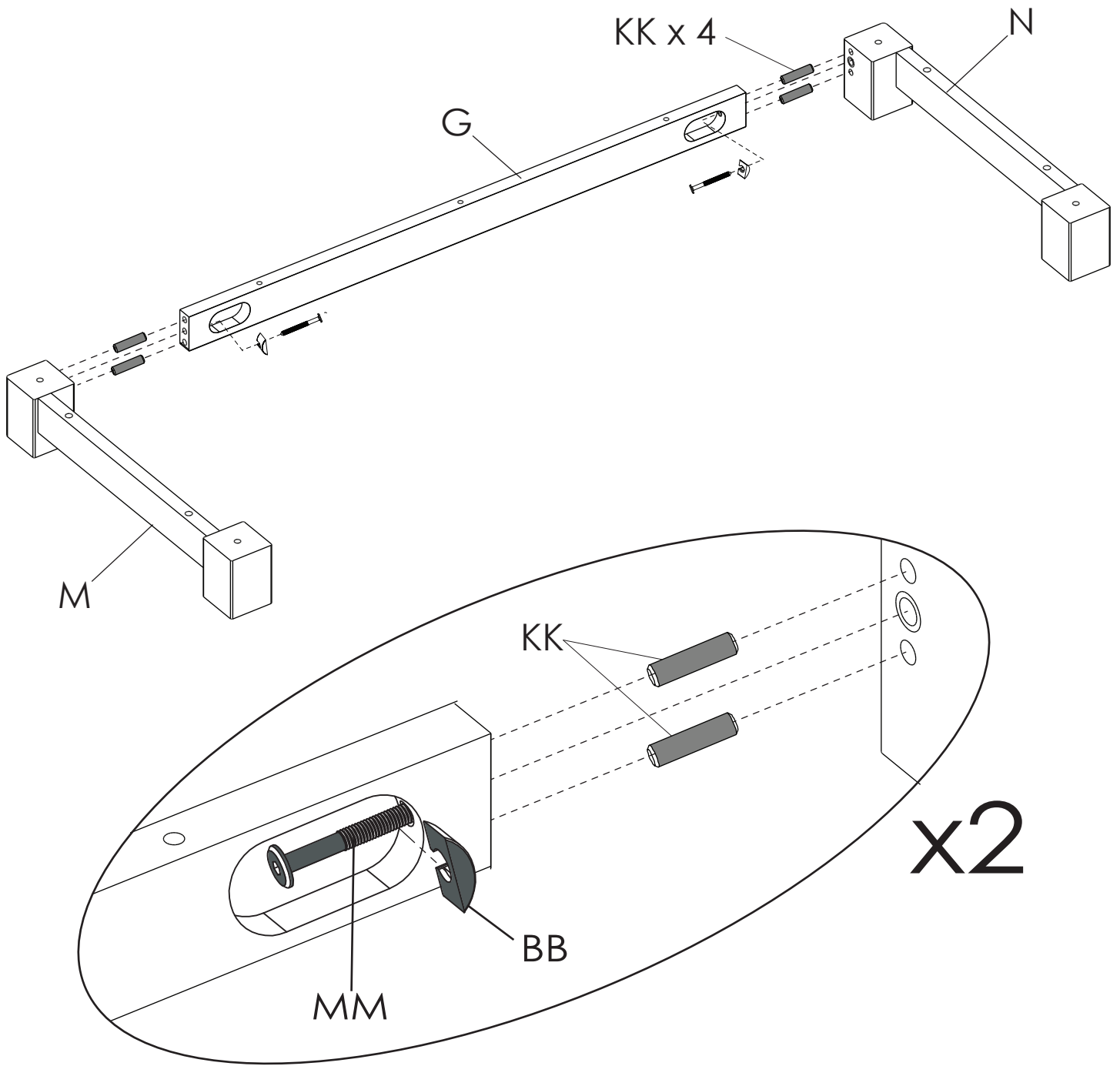



Step 5
Étape 5
Paso 5

Parts and tools required to complete step
Pièces et outils nécessaires au montage
Piezas y herramientas necesarias para completar este paso

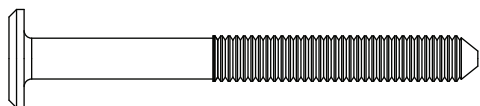
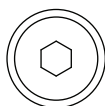

RR. 60mm Bolt x7
Boulon 60mm
Perno 60mm



KK. Φ 8x30mm Dowel x4
Cheville Φ 8x30mm
Pasador Φ 8x30mm

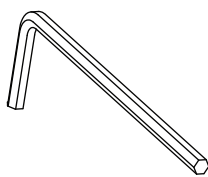

M4 Allen Wrench
Clé Allen M4
Llave Allen M4

Attach the Assembly from Step 4 to the Assembly from Step 3 using (4) Dowels (Part KK) and (7) 60mm Bolts (Part RR). Tighten with the M4 Allen Wrench.

Fixez le l'assemblage de l'étape 4 au l'assemblage de l'étape 3 à l'aide de (4) Chevilles (Pièce KK) et (7) boulons de 60 mm (Pièce RR). Serrez à l'aide de la clé hexagonale M4.

Fije el ensamblaje del paso 4 con la ensamblaje del paso 3 utilizando (4) Pasadores (Pieza KK) y (7) pernos de 60 mm (Pieza RR). Apriete todos los pernos utilizando la Llave Allen M4.

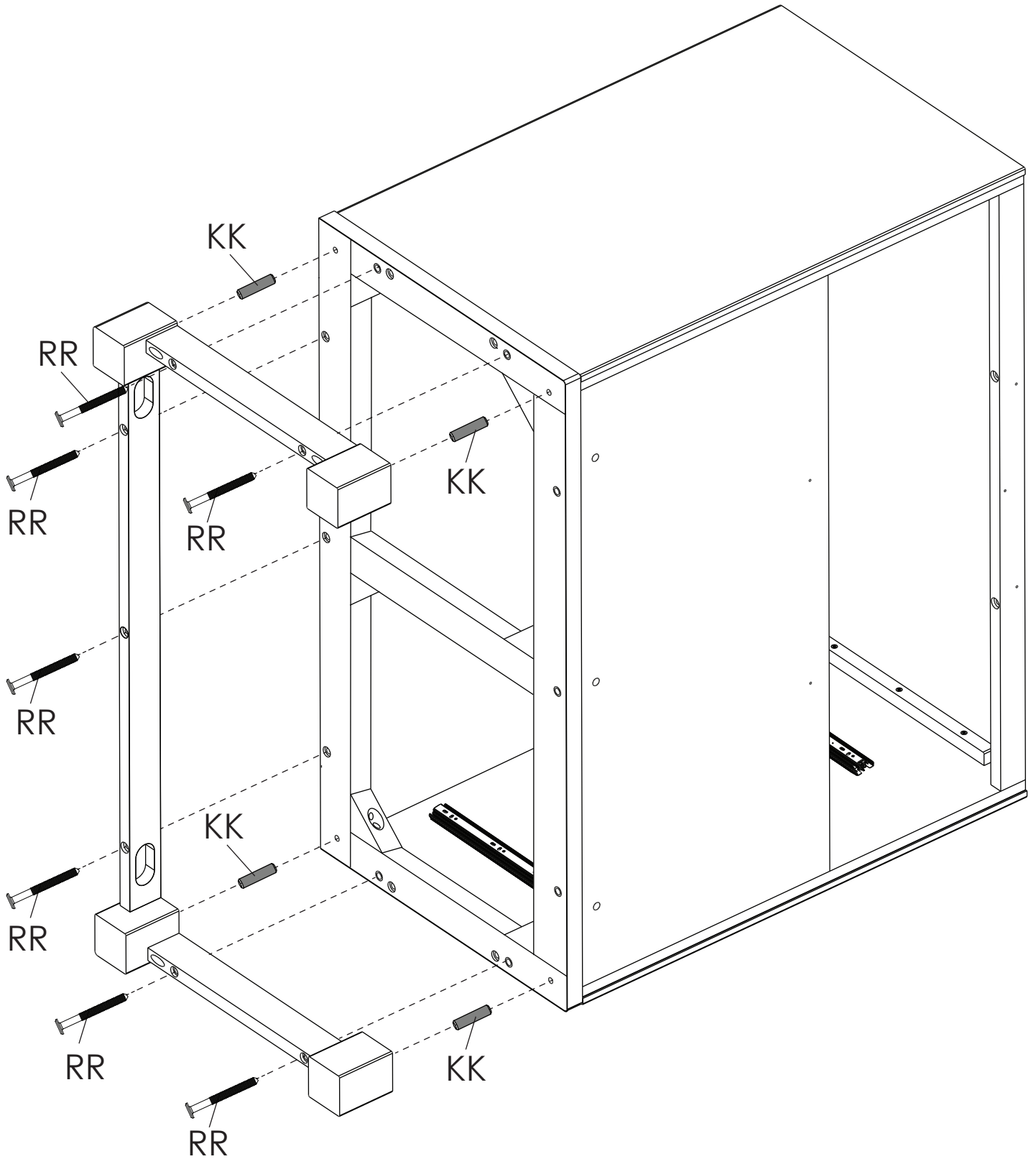



Step 6
Étape 6
Paso 6

Parts and tools required to complete step
Pièces et outils nécessaires au montage
Piezas y herramientas necesarias para completar este paso



KK. Φ 8x30mm Dowel x4
Cheville Φ 8x30mm
Pasador Φ 8x30mm

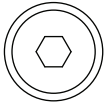

CC. 35mm Bolt x4
Boulon 35mm
Perno 35mm

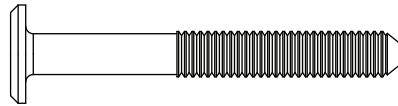
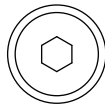

MM. 50mm Bolt x4
Boulon 50mm
Perno 50mm

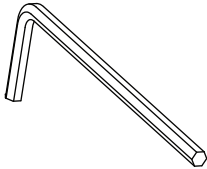

M4 Allen Wrench
Clé Allen M4
Llave Allen M4



M4 Ballend Screwdriver
tournevis M4 à tête sphérique
destornillador M4 con cabeza de bola

Insert (4) Dowels (Part KK) into the top of Both Sides.
Align the Top (Part C) with the Dowels.
Attach the Top Panel using (4) 35mm Bolts (Part CC) and (4) 50mm Bolts (Part MM) .
Tighten the Bolts with the Allen wrench.

Installez (4) Chevilles (Pièce KK) dans haut dedeux côtés.
Alignezle Panneau Supérieur (Pièce C) avec les Chevilles.
Fixer le Panneau supérieur à l'aide de (4) boulons de 35 mm (Pièce CC) et (4) boulons de 50 mm (Pièce MM) . Serrezavec la Clé Allen.

Instale (4) Pasadores (Pieza KK) encima deambos lados
Alineeel Panel superior (Pieza C) con los pasadores.
Fije el Panel superior utilizando (4) pernos de 35 mm (Pieza CC) y (4) pernos de 50 mm (Pieza MM) . Apriete con la Llave Allen.

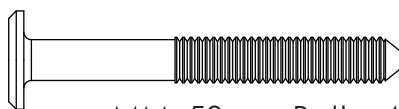
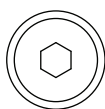

MM. 50mm Bolt x4
Boulon 50mm
Perno 50mm

KK. Φ 8x30mm Dowel x4
Cheville Φ 8x30mm
Pasador Φ 8x30mm

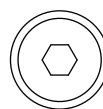
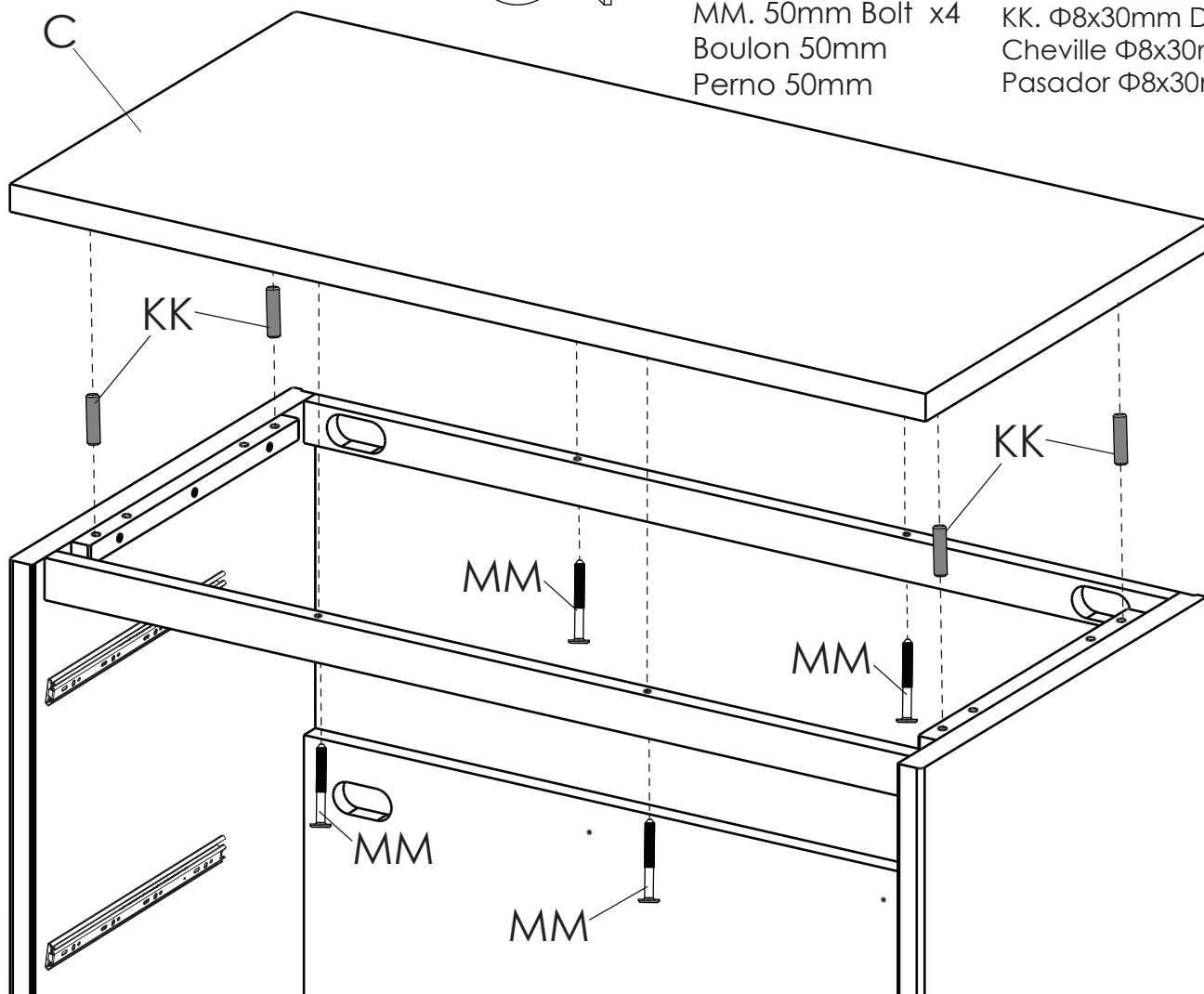

CC. 35mm Bolt x4
Boulon 35mm
Perno 35mm

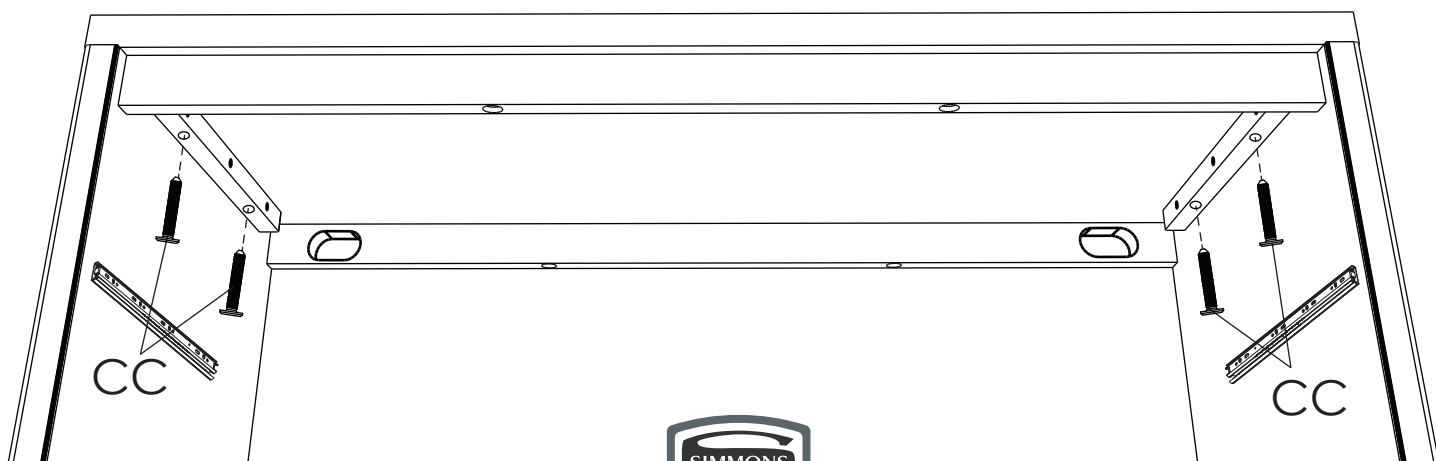



Step 7
Étape 7
Paso 7

Parts and tools required to complete step
Pièces et outils nécessaires au montage
Piezas y herramientas necesarias para completar este paso

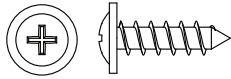

HH. Back Panel Screw x10
Vis pour Panneau Arrière
Tornillo de Panel Trasero

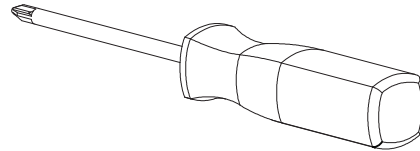

Phillips Screwdriver – Not included
Tournevis Phillips - non inclus
Destornillador Phillips – no incluido

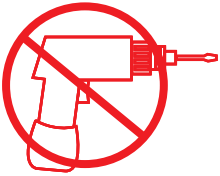

CAUTION: Do Not use a power screwdriver they can cause screws to break or strip.
ATTENTION: Ne Pas utiliser un tournevis électrique car les vis peuvent casser ou perdre leurs filets.
ATENCIÓN: No use un destornillador eléctrico ya que puede causar que los tornillos se rompan o rueden.

Attach Back Panel (Part D) using (10) Screws (Part HH), tighten with a Phillips screwdriver.

Fixez le panneau arrière (Pièce D) à l'aide de (10) vis (Pièce HH), serrez à l'aide d'un tournevis cruciforme.

Una el panel posterior (Pieza D) utilizando (10) tornillos (Pieza HH), apriete utilizando un destornillador Philips.



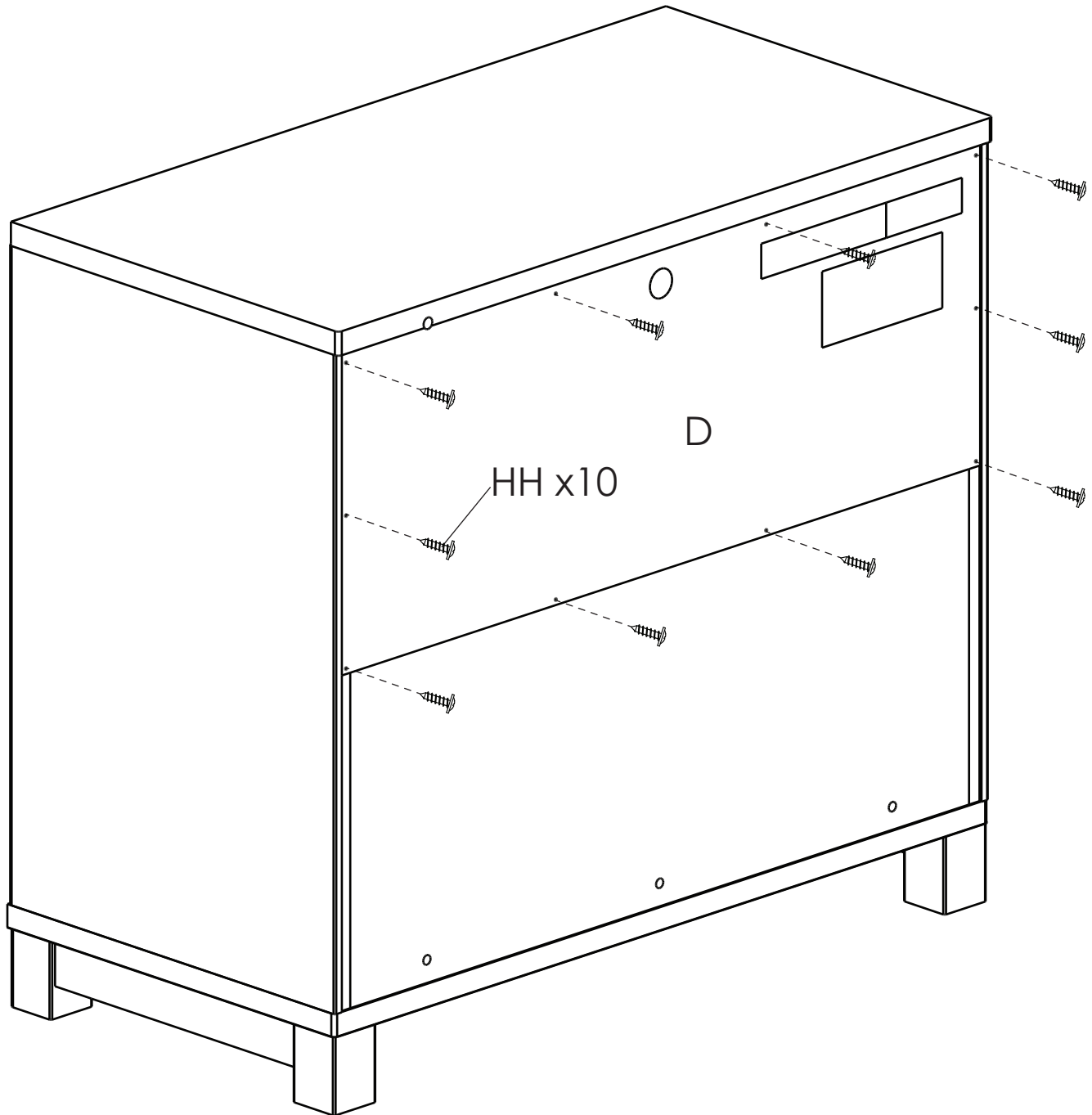



Step 8
Étape 8
Paso 8

Parts and tools required to complete step
Pièces et outils nécessaires au montage
Piezas y herramientas necesarias para completar este paso



LL. Cam bolt x2
Goujon D'Assemblage Rapide
Perno De Leva

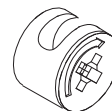

AA. Cam lock x2
Vis D'Assemblage Rapide
Cerradura de Leva

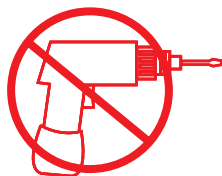

CAUTION: Do Not use a power screwdriver they can cause screws to break or strip.

ATTENTION: Ne Pas utiliser un tournevis électrique car les vis peuvent casser ou perdre leurs filets.

ATENCIÓN: No use un destornillador eléctrico ya que puede causar que los tornillos se rompan o rueden.

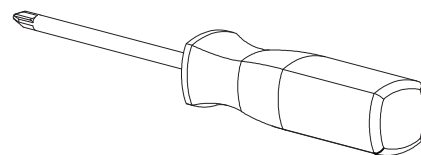

Phillips Screwdriver – Not included
Tournevis Phillips - non inclus
Destornillidor Phillips – no incluido

1. Insert Cam Bolt (Part LL) into Changing Top Right Side (Part W).
2. Insert (1) cam lock (part AA) into the holes on the side of the Changing Top Front (Part T).
3. Attach Changing Top Right Side (Part W) to the Changing Top Front (Part T) . Insert and turn the cam lock clockwise to tighten using a phillips screwdriver.
4. Attach Changing Top Left Side (Part U) in the same manner

1. Insert le boulon à came (pièce LL) en coté droit du plan à langer (Pièce W).
2. Insert (1) serrures (pièce AA) dans les trous sur le côté de la partie frontale du plan à langer (Pièce T).
3. Fixer le coté droit du plan à langer (Pièce W) à la partie frontale du plan à langer (Pièce T). Insérer et tourner la came de verrouillage dans le sens horaire pour serrer l'aide d'un tournevis cruciforme.
4. Fixer le coté gauche du plan à langer (Pièce U) de la même façon.

1. Inserte (1) perno de leva (Pieza LL) en la lado derecho del cambiador (pieza W).
2. Inserte (1) cerraduras (pieza AA) en los orificios en el lado del parte frontal del cambiador (pieza T).
3. Fijar el lado derecho del cambiador (pieza W) con la parte frontal del cambiador (pieza T). Inserte y gire la leva de la derecha para apretar con un destornillador.
4. Fijar el lado izquierdo del cambiador (pieza U) de la misma manera.



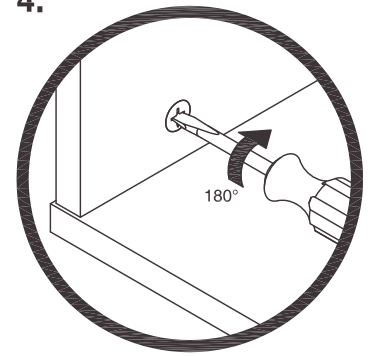
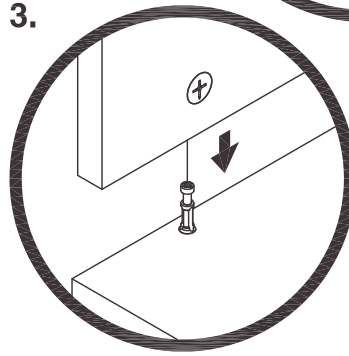
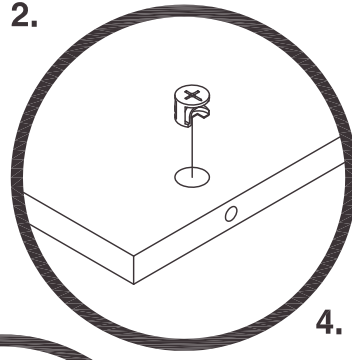
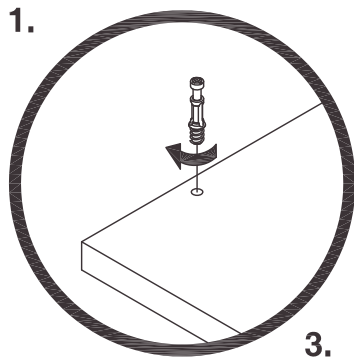

How to use the cam lock system
 comment utiliser le système de
 verrouillage à came
 cómo utilizar la leva de bloqueo

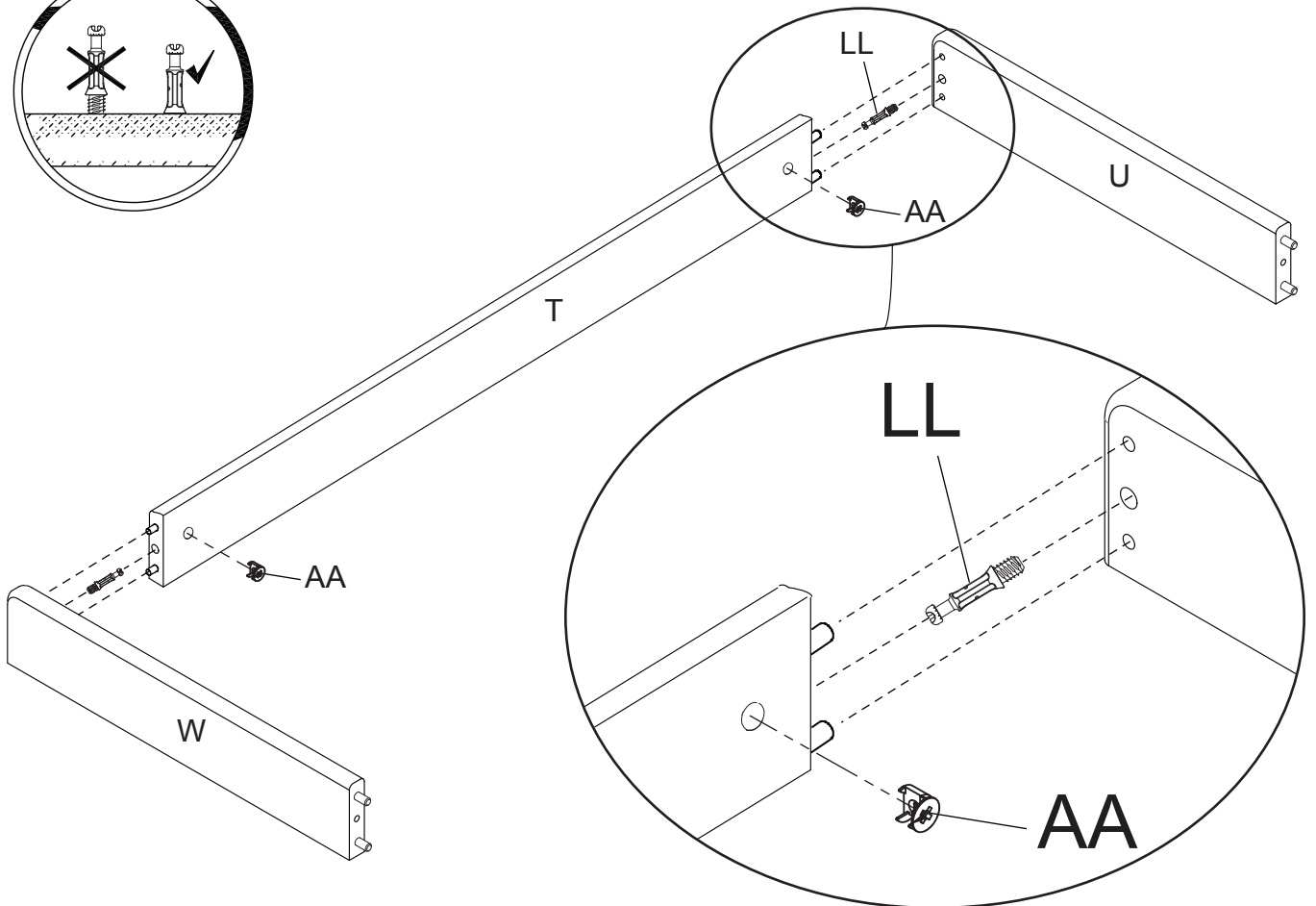
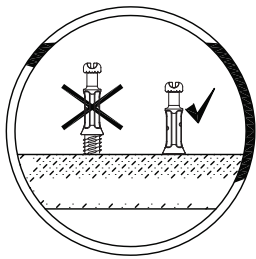



Step 9
Étape 9
Paso 9

Parts and tools required to complete step
 Pièces et outils nécessaires au montage
 Piezas y herramientas necesarias para completar este paso

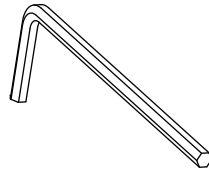
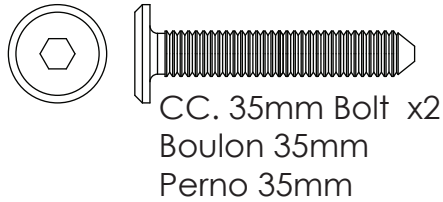

M4 Allen Wrench
 Clé Allen M4
 Llave Allen M4

Attach Changing Top Back (Part S) to the Right and Left Sides using (2) M6x35mm bolts (part CC). Tighten with the Allen Wrench.

Fixer la partie postérieure du plan à langer (Pièce S) au cotés droit et gauche à l'aide de (2) boulons M6 x 35mm (Pièce CC). Serrez avec la Clé Allen.

Fijar la parte posterior del cambiador (Pieza S) a los lados derecho e izquierdo (2) pernos de 35mm (pieza CC). Apriete con la Llave Allen.



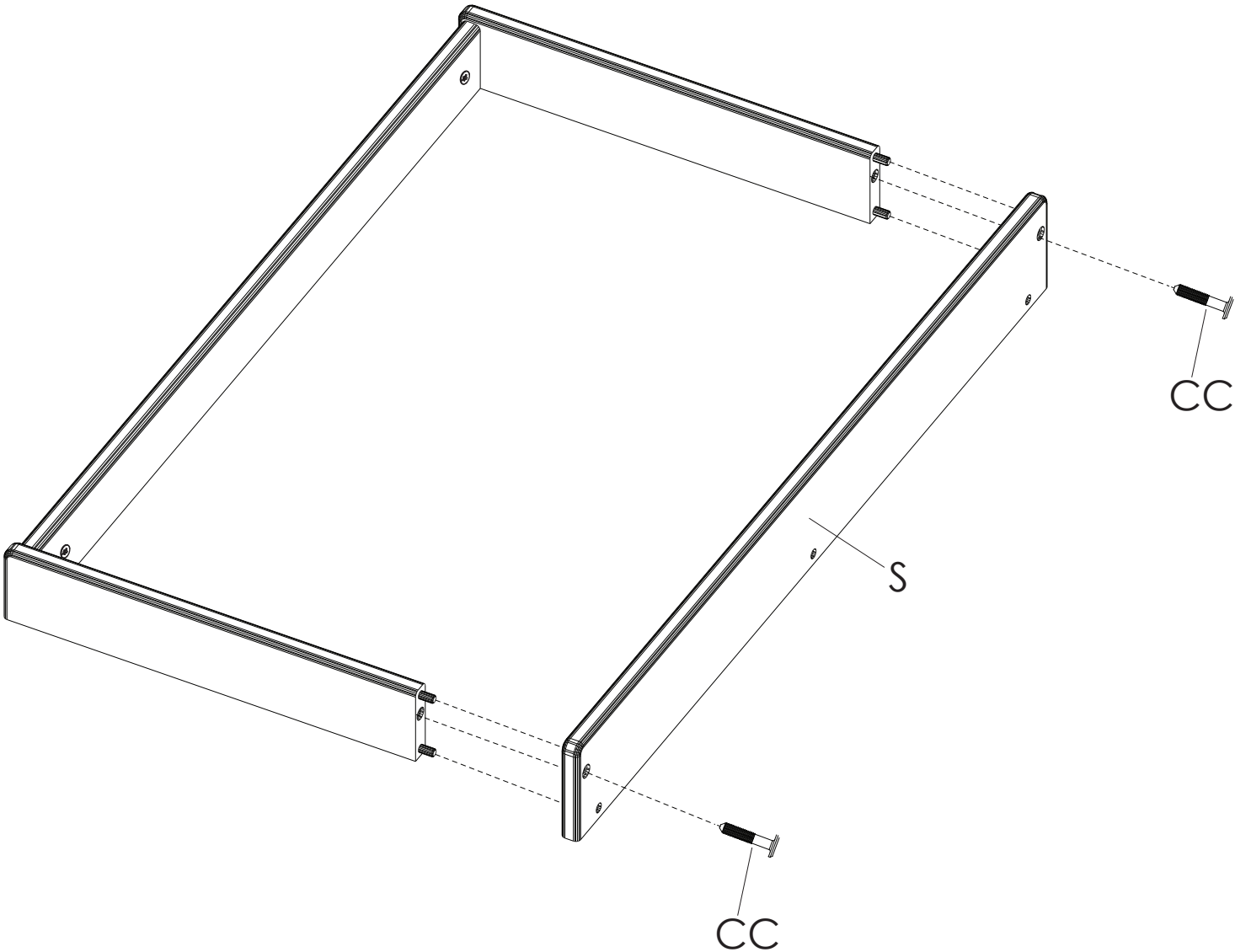



Step 10
Étape 10
Paso 10

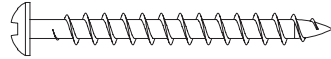

FF. 40mm Screw x3
Vis 40mm
Tornillo 40mm

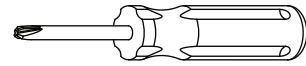

Phillips Screwdriver – Not included
Tournevis Phillips - non inclus
Destornillador Phillips – no incluido

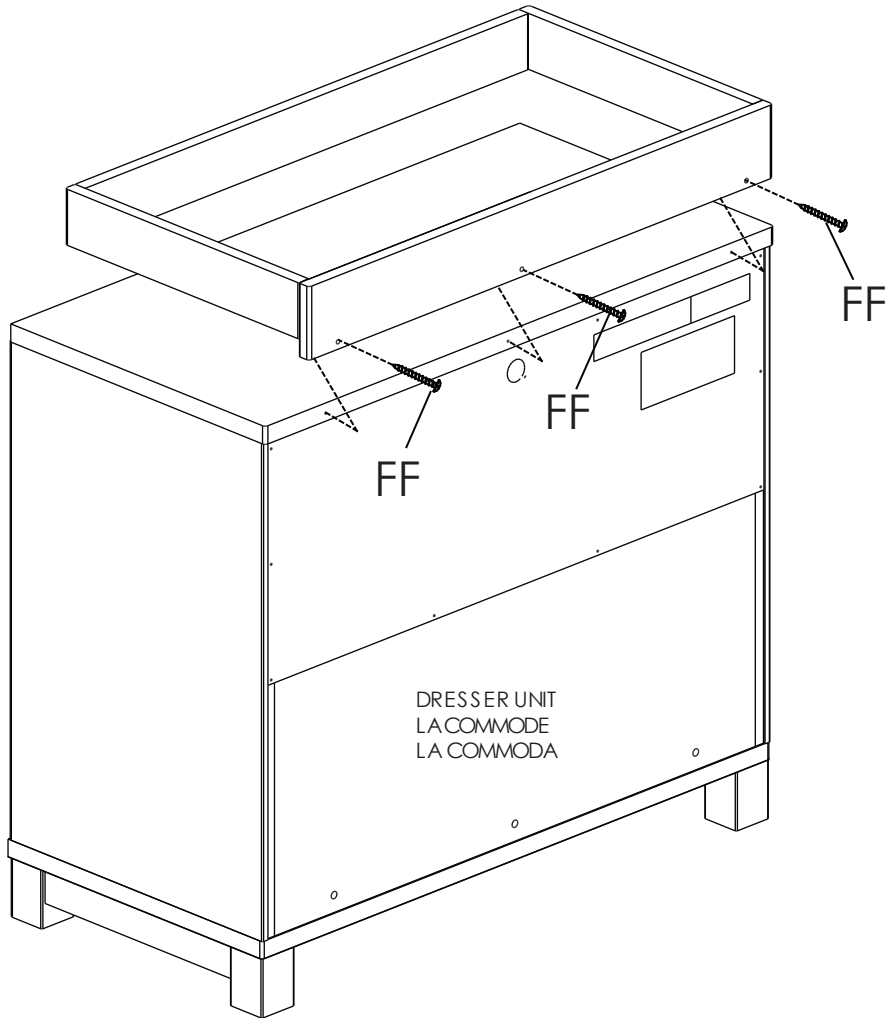

1. Set the Assembled Changing Top on the top of the Dresser as shown.
2. Insert (3) 40mm screws (Part FF) through the back of the Changing Top, into the pre drilled holes the dresser.
3. Tighten with a Phillips Screwdriver.

1. Placer la Table à Langer maintenant assemblée sur le dessus de la commode.
2. Insérer (3) vis 40mm (pièce FF) à partir de l'arrière de la table à langer, jusque dans les trous de guidage que l'on vient de percer dans la commode.
3. Serrer au moyen d'un tournevis phillips.

1. Poner el equipó de ensamblaje encima del cambiador.
2. Inserta (3) tornillos 40 mm (pieza FF) en la parte de atrás en los wecos pilot.
3. Apriete con destornillador phillips.



⚠️WARNING

Fall Hazard Children have suffered serious injuries after falling from changing tables. Falls can happen quickly.

- **STAY** within arm's reach of the child.
- **ALWAYS** secure this unit to the support surface using the screws provided. See instructions.
- Read all instructions before use of the changing top.
- **KEEP THESE INSTRUCTIONS IN A SAFE PLACE FOR FUTURE USE.**
- Inspect the changing top periodically. Do not use the changing top if it is damaged or broken. Contact Delta Children's Products with any questions.
- Tighten all loose screws and bolts before each use.
- The maximum recommended weight of the child is 30lbs for the changing unit.
- Secure the changing unit only to Delta Children's Products item W342030.
- The changing pad used should be 32" x 16" with a maximum thickness of 1".

⚠️AVERTISSEMENT

Danger de chutes. Des enfants ont souffert de sérieuses blessures après être tombés des tables à langer. Les chutes peuvent arriver rapidement.

- **RESTEZ** à portée de bras de l'enfant.
- Sécurisez **TOUJOURS** cette unité à la surface de support à l'aide des vis fournies. Voir les instructions.
- Lisez toutes les instructions avant d'utiliser la table à langer
- **CONSERVER CES INSTRUCTIONS DANS UN ENDROIT SÛR POUR RÉFÉRENCE ULTÉRIEURE.**
- Inspecter régulièrement la table à langer. Ne pas l'utiliser si elle est endommagée ou brisée. Si vous avez des questions contactez Delta Children's Products.
- Serrer tous les boulons et vis desserrés avant chaque usage.
- La table à langer ne doit pas être utilisée pour un enfant pesant plus de 13,6 kg (30 lb.).
- La table à langer doit être fixé à seulement Delta Children's Products produit W342030.
- Le coussin à langer doit mesurer 32 po x 16 po et avoir une épaisseur maximale de 1 po

⚠️ADVERTENCIA

Peligro de caídas. Hay niños que han sufrido lesiones serias al caer de cambiadores. Las caídas pueden ocurrir en un instante.

- **MANTENERSE** al alcance de la mano del niño.
- Asegurar **SIEMPRE** esta unidad a la superficie de soporte utilizando los tornillos provistos. Ver las instrucciones.
- Lea todas las instrucciones antes de usar el cambiador.
- **COLOQUE ESTAS INSTRUCCIONES EN UN LUGAR SEGURO PARA SU USO FUTURO.**
- Inspeccione este cambiador periódicamente. No use el cambiador si esta dañado o roto. Póngase en contacto con Delta Children's Products para formular preguntas.
- Apriete los tornillos y pernos flojos antes de cada uso.
- El peso máximo recomendado para los niños que usen el cambiador es 30 libras (13,6 kilos).
- Asegure el cambiador sólo al producto Delta Children's Products W342030.
- La almohadilla usada debe ser 32 x 16 pulgadas con un grosor máximo de 1 pulgada.

STEP #11

ÉTAPE N°11

PASO #11

Tipover Restraint

Dispositif de non-renversement

Protección contra volcamiento

▲ WARNING

Use of tip-over restraints may only reduce, but not eliminate, the risk of tip-over.

Do not attempt to screw into the wallboard only. You must screw into a wood wall stud or other wood structure such as securely attached baseboard. If your wall is not wood stud construction, see your local hardware store or home center for a wall anchor system that will hold a pull force of 50 LBS in your wall type. If you are unsure of how to locate the wood stud, or of what type of wall you have, contact a professional contractor.

▲ AVERTISSEMENT

L'utilisation de dispositif anti-renversement peut uniquement réduire les risques de renversement, mais ne les élimine pas totalement.

Ne tentez pas de visser dans le panneau de revêtement uniquement. Vous devez visser dans un poteau mural en bois ou toute autre structure en bois telle qu'une plinthe solidement fixée. Si votre mur n'est pas construit de montants de bois, voyez votre quincaillerie locale ou centre de rénovation pour une ancre de mur pouvant supporter 50 livres dans votre type de mur. Si vous êtes incertain par rapport à comment localiser le montant ou à quel type de mur vous avez, contactez un entrepreneur professionnel.

▲ ADVERTENCIA

El uso de herramientas de contención de vuelcos tan solo puede reducir, pero no eliminar, el riesgo de vuelco.

No intente atornillar a paredes hechas únicamente de paneles. Debe atornillar en un pilar u otra estructura de madera similar, como un zócalo fijado de manera segura. Si su pared no tiene vigas de Madera, visite su ferretería o tienda del ramo más cercana para conseguir un sistema de anclaje que soporte una fuerza de tiraje de hasta 50 LBS (22,7 Kgs) para su tipo de muro. Si no está seguro sobre cómo encontrar la viga de madera o tiene dudas sobre el tipo de muro, contacte a un contratista profesional.

- 1) Locate the through holes in the back of the dresser.
- 2) Align the hole to be used with the wood wall stud (For Open Bottom Installation, use wood wall stud closest to center)

- 1) Repérez les trous percés au dos de la commode.
- 2) Alignez le trou à utiliser sur le poteau mural en bois (Pour une installation à fond ouvert, utilisez le poteau mural le plus près du milieu)

- 1) Ubique los orificios pasantes en la parte posterior del mueble.
- 2) Alinee el orificio que utilizará con el pilar de la pared (para una instalación con fondo abierto, utilice el pilar de madera más cercano al centro)

3) Make a pencil mark on the wall using the wood rail as a guide, pencil mark must be over wood wall stud. Then move the case away from the wall.

3) Faites une marque sur le mur à l'aide d'un crayon en vous servant du barre en bois comme guide, la marque au crayon doit être au-dessus du poteau mural en bois. Ensuite, déplacez la caisse afin de l'éloigner du mur.

3) Utilizando un lápiz, haga una marca en la pared utilizando el barra de madera como guía; la marca debe estar sobre el pilar de madera. Luego, aleje la carcasa de la pared.

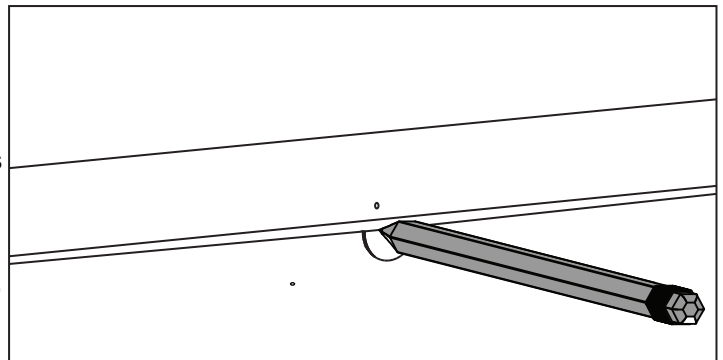

4) Drill Ø1/8" hole at Pencil Mark, in wood wall stud

4) Percez un trou de 1/8 po de diamètre à l'emplacement de la marque au crayon, dans le poteau mural en bois

4) Perfore un orificio de Ø1/8" en la marca del lápiz, sobre el pilar de madera

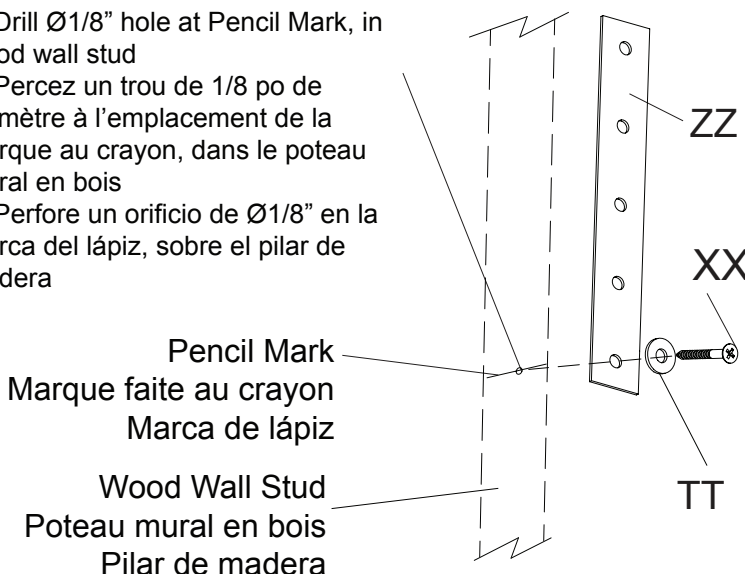

5) Attach the Tip-over restraint strap (ZZ) to the wall using (1) Long Screw (XX) and (1) washer (TT) as shown. The screw MUST be installed into a wood wall stud (See WARNINGS for additional information).

5) Fixez la sangle du dispositif de non-renversement (ZZ) au mur à l'aide de (1) vis longue (XX) et de (1) rondelle (TT) tel qu'illustré. La vis DOIT être serrée dans un poteau mural en bois (Pour de plus amples informations, veuillez vous référer aux AVERTISSEMENTS).

5) Fije la correa de retención contra volcamiento (ZZ) a la pared utilizando (1) tornillo largo (XX) y (1) arandela (TT), como se indica. El tornillo DEBE instalarse en un pilar de madera (para obtener más información consulte las ADVERTENCIAS).

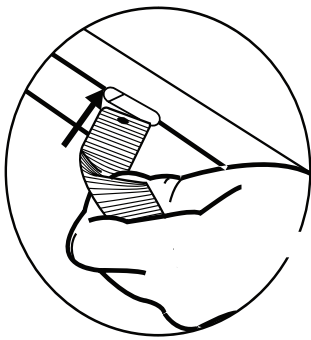

NOTE: Be sure to attach any accessory items to case before completing this step.
 6) Feed the Tipover Restraint through the hole as you place the dresser in it's final position.
 REMARQUE : Veuillez à fixer tous accessoires sur la caisse avant de l'exécution de cette étape.
 6) Faites entrer le dispositif de non-renversement à travers le trou lorsque vous placez la commode dans s position finale.
 NOTA: Asegúrese de fijar todos los accesorios a la carcasa antes de completar este paso.
 6) Pase el elemento de retención a través del orificio, a medida que posiciona el mueble en su posición final.

7) Pull the Tip-over restraint through the hole and fasten it securely to the case using (1) 15mm screw (YY) and (1) washer (TT).
 7) Tirez le dispositif de non-renversement à travers le trou, puis fixez-le solidement sur la caisse à l'aide de (1) vis de 15 mm (YY) et de (1) rondelle (TT).
 7) Pase el elemento de retención a través del orificio y fíjelo con seguridad a la carcasa utilizando (1) tornillo de 15 mm (YY) y (1) arandela (TT).

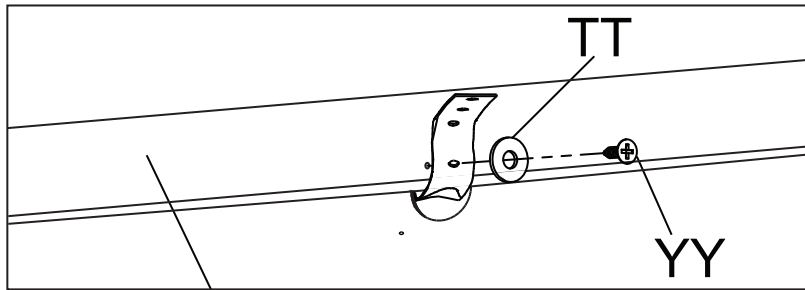

Top Back Rail
 Barre Arrière Supérieur
 Barra Trasero Superior

9) Pull case AWAY from wall until Restraint is SNUG.
 9) Tirez la caisse afin de L'ÉLOIGNER du mur jusqu'à ce que le dispositif de non-renversement soit BIEN AJUSTÉ
 9) Jale la carcasa ALEJÁNDOLA de la pared hasta que la retención esté TENSA.

10) Ensure restraint is not loose.
 10) Assurez-vous que le dispositif de non-renversement n'est pas desserré.
 10) Asegúrese de que la retención no esté suelta.

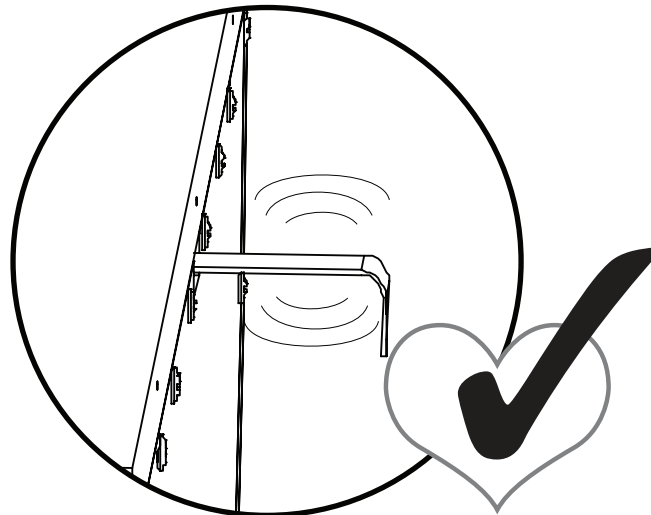
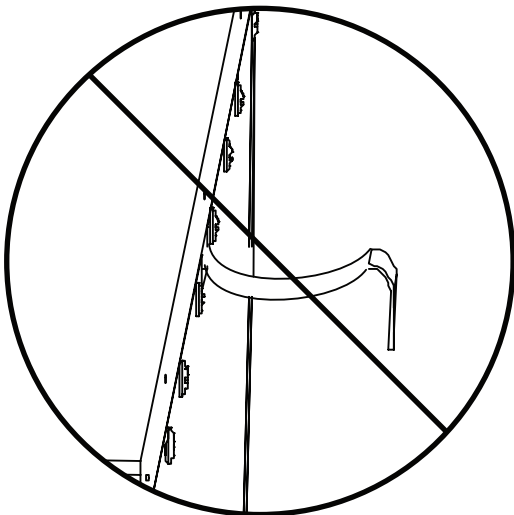



Step 12
Étape 12
Paso 12

Parts and tools required to complete step
Pièces et outils nécessaires au montage
Piezas y herramientas necesarias para completar este paso

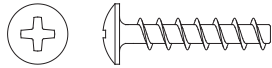

GG. 20mm Screw x12
Vis 20mm
Tornillo 20mm

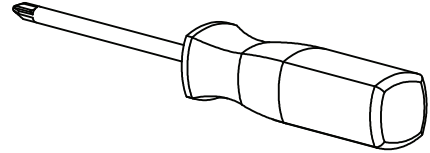

Phillips Screwdriver – Not included
Tournevis Phillips - non inclus
Destornillador Phillips – no incluido

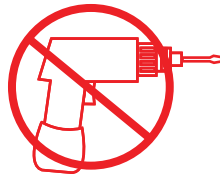

CAUTION: Do Not use a power screwdriver they can cause screws to break or strip.
ATTENTION: Ne Pas utiliser un tournevis électrique car les vis peuvent casser ou perdre leurs filets.
ATENCIÓN: No use un destornillador eléctrico ya que puede causar que los tornillos se rompan o rueden.

Slide Drawer Bottom (Part R) into the grooves. Attach (2) Drawer Sides (Part X) to the Drawer Front (Part K, P) with (4) 20mm Screws (Part GG). Note: Grooves in Bottom must align. Tighten With Phillips Screwdriver. Repeat this step until 3 drawers are complete.

Glisser le fond du tiroir (Pièce R) dans les rainures. Fixer (2) Barre de Tiroir (Pièce X) à l'avant du tiroir (Pièce K,P) à l'aide de (4) vis 20mm (Pièce GG). Remarque: Les rainures inférieures doivent être alignées. Serrer avec un tournevis Phillips. Répéter cette étape jusqu'à ce que les 3 tiroirs soient montés.

Deslice la Fondo de la gaveta (Pieza R) hacia las ranuras. Fije (2) Barra de la Gaveta (Pieza X) a la parte frontal de la gaveta (Pieza K,P) utilizando (4) tornillos 20mm (Pieza GG). Nota: Las ranuras al inferior deben alinearse. Apriete utilizando un destornillador Phillips. Repitaestepaso hasta haber completado las 3 gavetas .

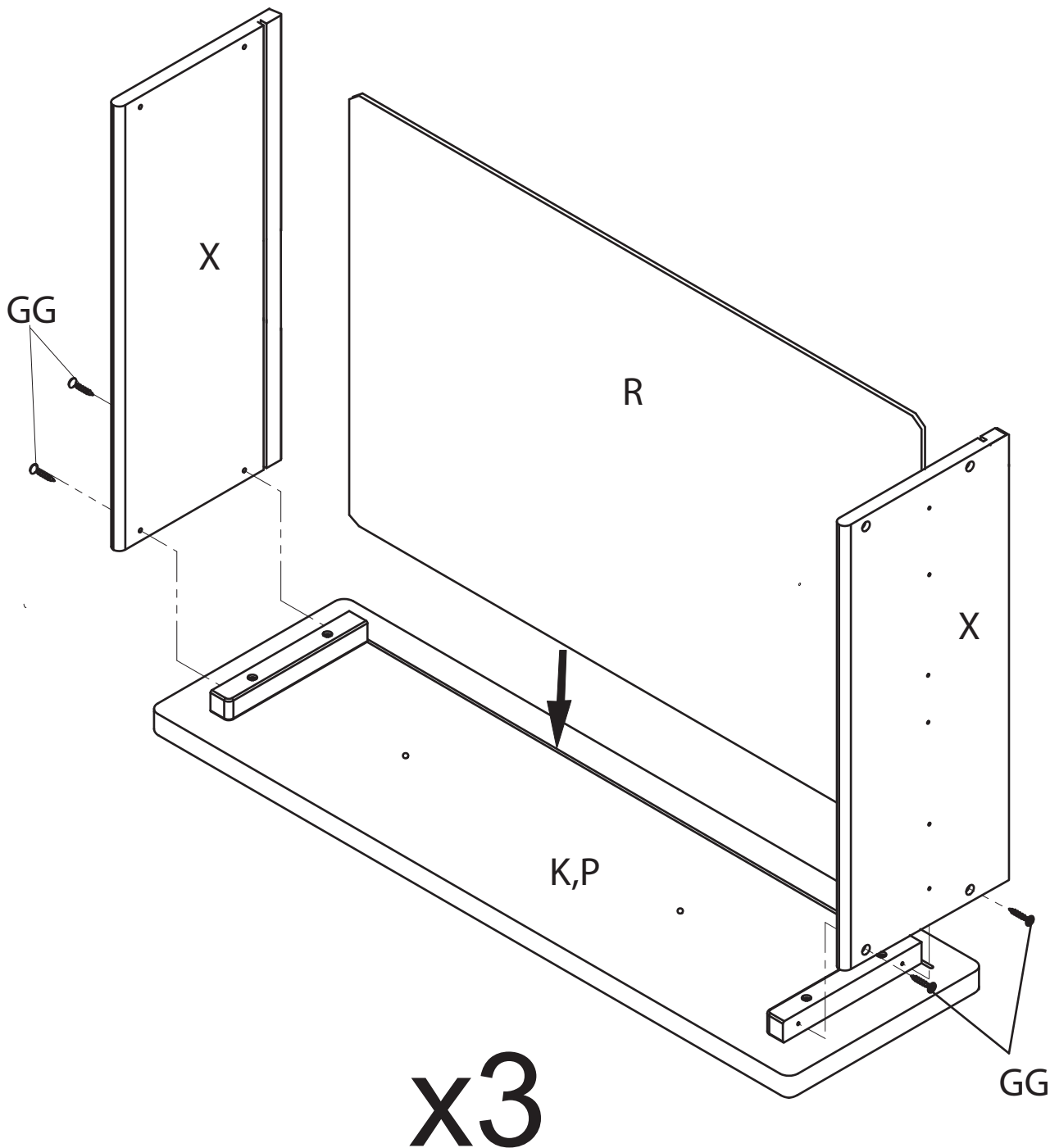



Step 13
Étape 13
Paso 13

Parts and tools required to complete step
Pièces et outils nécessaires au montage
Piezas y herramientas necesarias para completar este paso

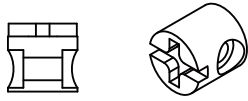

EE. PLASTIC BARREL NUT x12
Écrous à Manchon en Plastique
Tuerca de Barril Plásticas

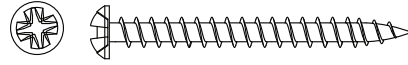

FF. 40mm SCREW x12
Vis 40mm
Tornillo 40mm

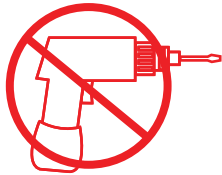

CAUTION: Do Not use a power screwdriver they can cause screws to break or strip.
ATTENTION: Ne Pas utiliser un tournevis électrique car les vis peuvent casser ou perdre leurs filets.
ATENCIÓN: No use un destornillador eléctrico ya que puede causar que los tornillos se rompan o rueden.



Phillips Screwdriver – Not included
Tournevis Phillips - non inclus
Destornillidor Phillips – no incluido

Install the Drawer Back (Part L), using (4) 40mm Screws (Part FF) and (4) Plastic Barrel Nuts (Part EE). Note: Grooves In Bottom Must Align. Repeat this step until 3 drawers are complete.

Installer le arrière du tiroir (Pièce L), à l'aide de (4) vis 40mm (Pièce FF) et de (4) Écrous à portée cylindriques en plastique (Pièce EE). Remarque: Les rainures inférieures doivent être alignées. Serrer avec un tournevis Phillips. Répéter cette étape jusqu'à ce que les 3 tiroirs soient montés.

Instale el Trasera de la gaveta (Pieza L) utilizando (4) tornillos de 40 mm (Pieza FF) y (4) tuercas cilíndricas plásticas (Pieza EE). Nota: Las ranuras al inferior deben alinearse. Apriete utilizando un destornillador Phillips. Repita este paso hasta haber completado las 3 gavetas.



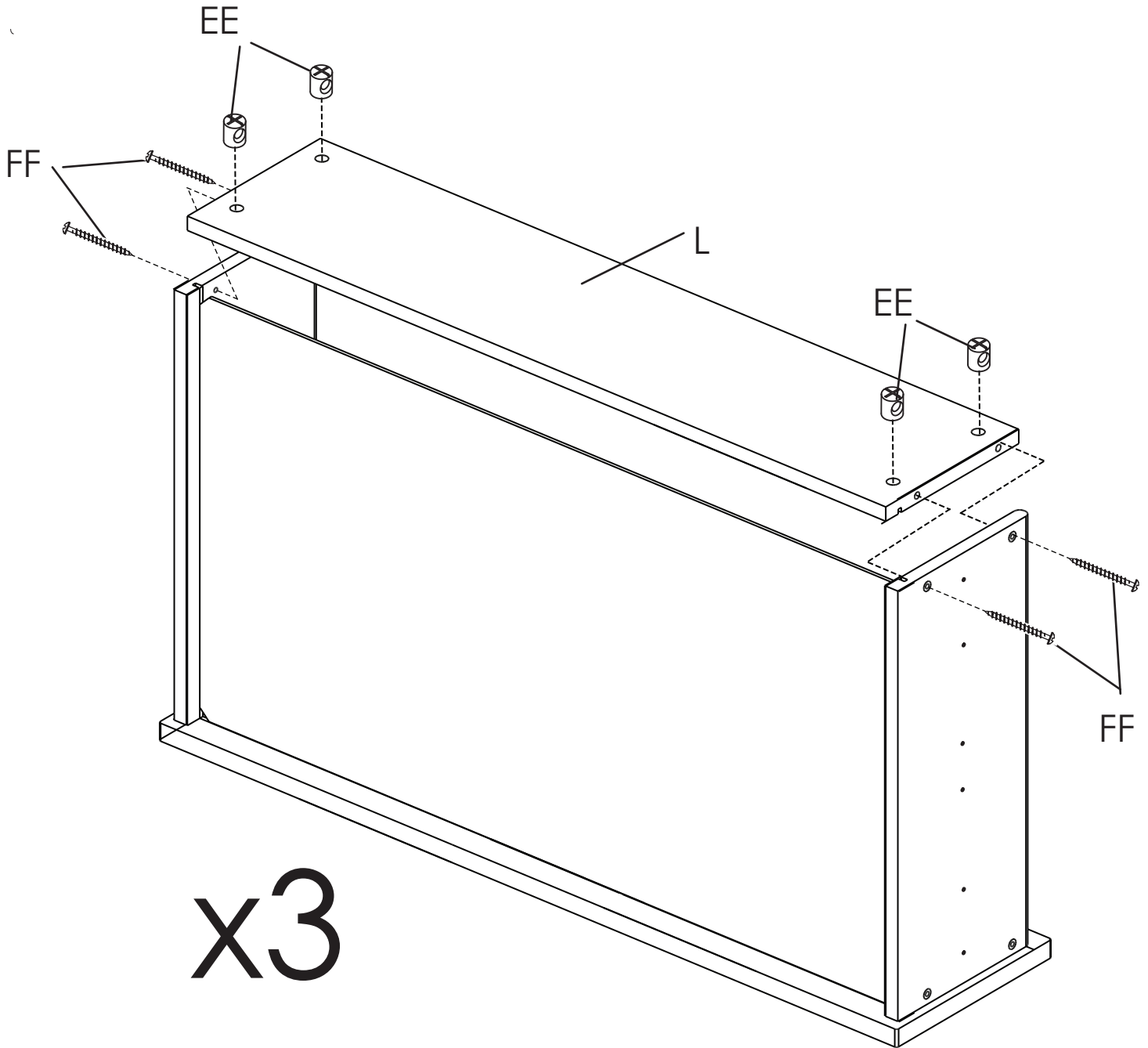



Step 14
Étape 14
Paso 14

Parts and tools required to complete step
Pièces et outils nécessaires au montage
Piezas y herramientas necesarias para completar este paso

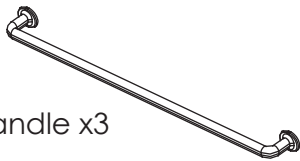

PP1. Handle x3
Tirage
Manija



PP2. Handle Screw x6
Vis de Tirage
Tornillo para Manija

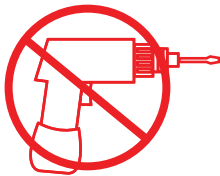

CAUTION: Do Not use a power screwdriver they can cause screws to break or strip.
ATTENTION: Ne Pas utiliser un tournevis électrique car les vis peuvent casser ou perdre leurs filets.
ATENCIÓN: No use un destornillador eléctrico ya que puede causar que los tornillos se rompan o rueden.



Phillips Screwdriver – Not included
Tournevis Phillips - non inclus
Destornillador Phillips – no incluido

Attach (1) Handle (Part PP1) to Drawer Assembly using (2) Knob Screws (Part PP2).
Repeat this step until 3 drawers are complete.

Fixer le (1) Tirage (Pièce PP1) au montage assemblé du tiroir à l'aide d'(2) vis de Tirage (Pièce PP2). Répéter cette étape jusqu'à ce que les 3 tiroirs soient montés.

Fije la (1) Manija (Pieza PP1) al ensamblaje de la gaveta utilizando (2) tornillos para Manija (Pieza PP2). Repita este paso hasta haber completado las 3 gavetas.

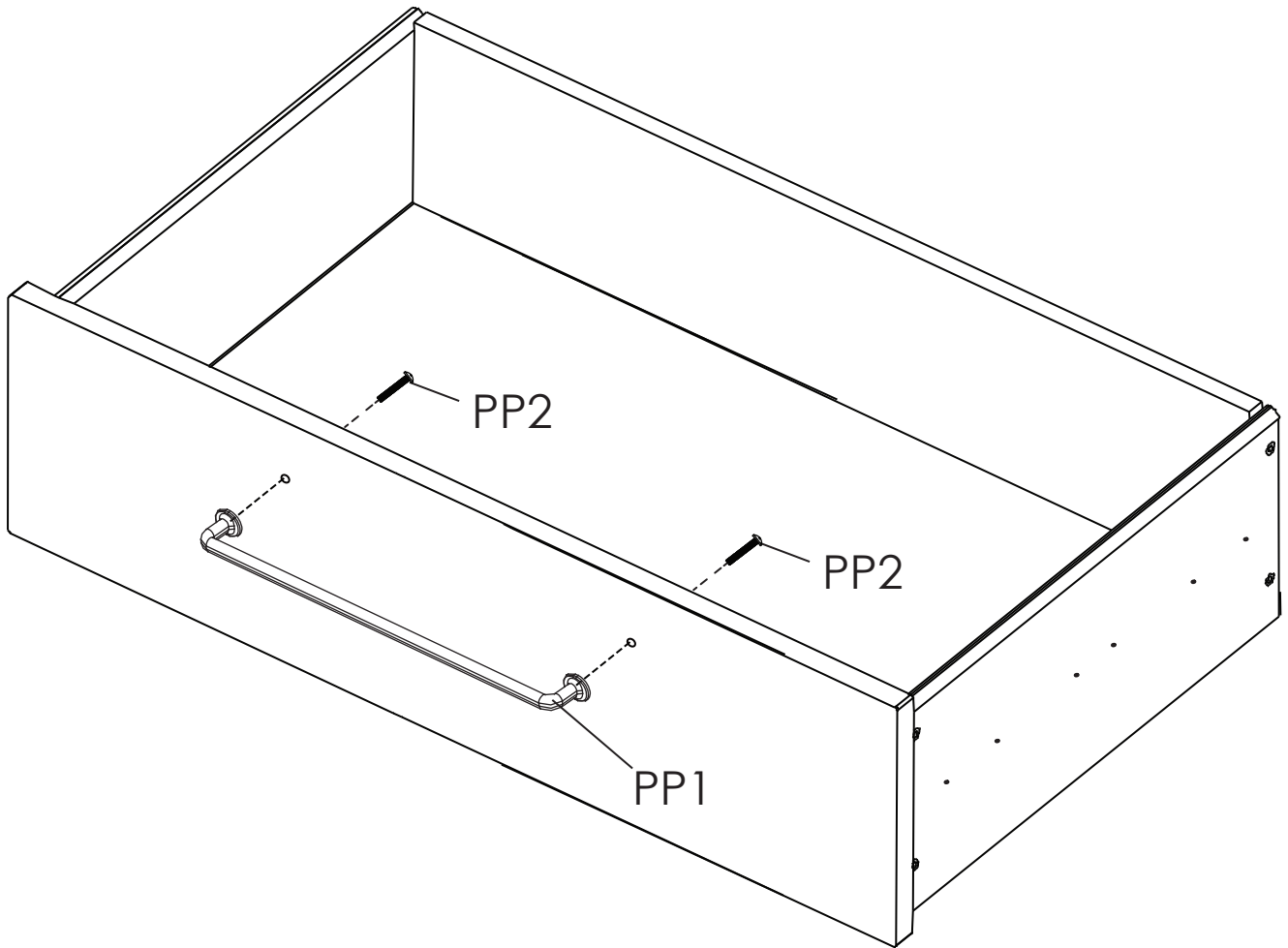



Step 15
Étape 15
Paso 15

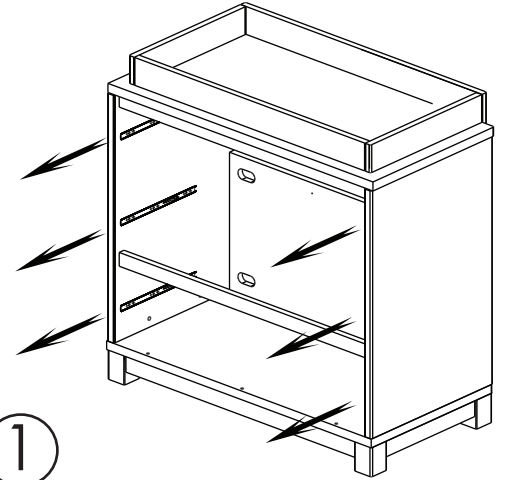
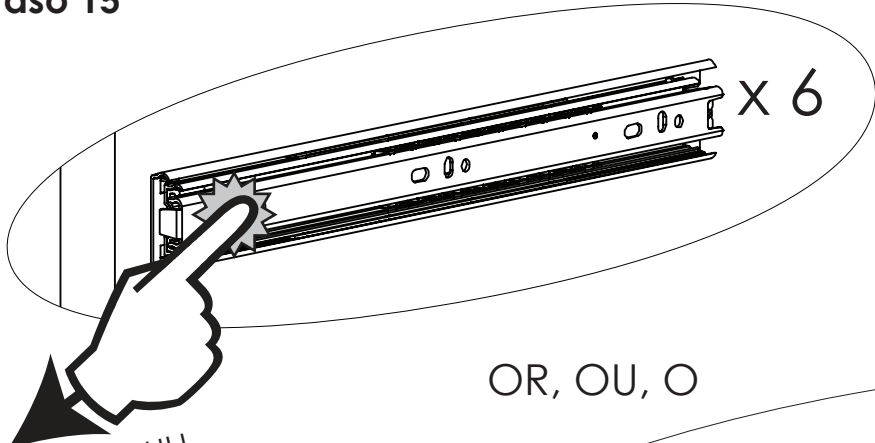

1

OR, OU, O

Press & PULL
Glisser & TIRER
Empujar & SAQUE

PULL
TIRER
SAQUE

Allen Wrench
Clé Allen
Llave Allen

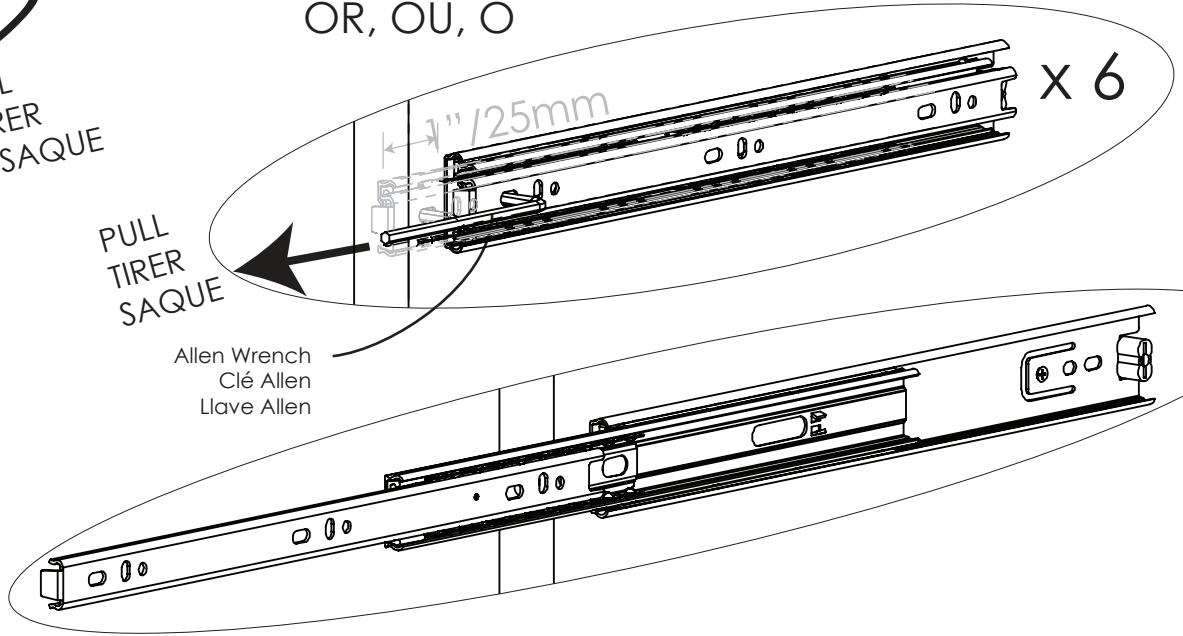

Left/Gauche/Izquierdo

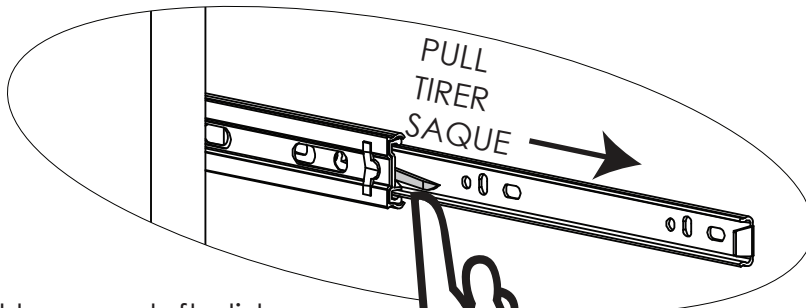

Lift lever on left glide up
Soulevez le levier à gauche
Levantat la palanca a la
izquierda se deslizan hacia
arriba

Press lever on right glide
down Glisser sur le levier sur
la droite glisser vers le bas
Empujar la palanca a la
derecha se deslizan por

2

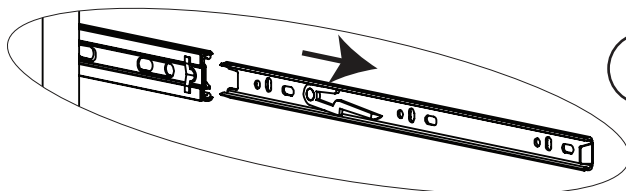

3

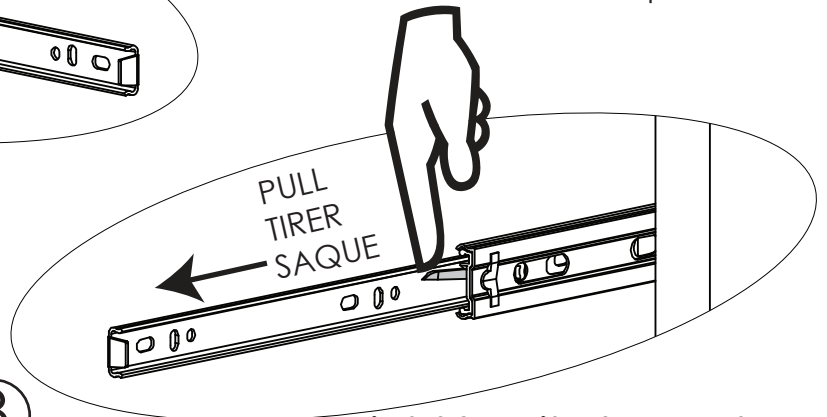

Right/Droite/Derecho





The silver portion of the glide must be pulled to the front of the glide when assembling the drawer into the case.

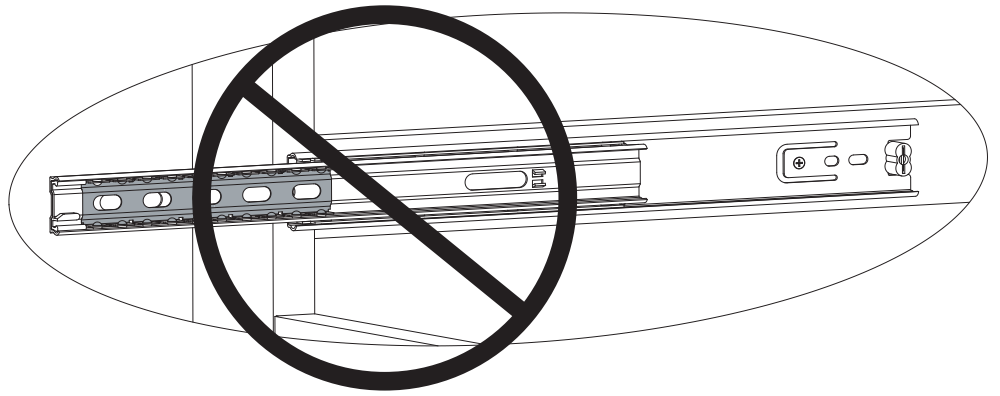

La partie argentée du glissement de doit être tirée vers l'avant de la glisse lors du montage du tiroir dans le boîtier.

La parte plateada de la guía de la gaveta debe estar al frente de la guía cuando se está armando la cómoda.

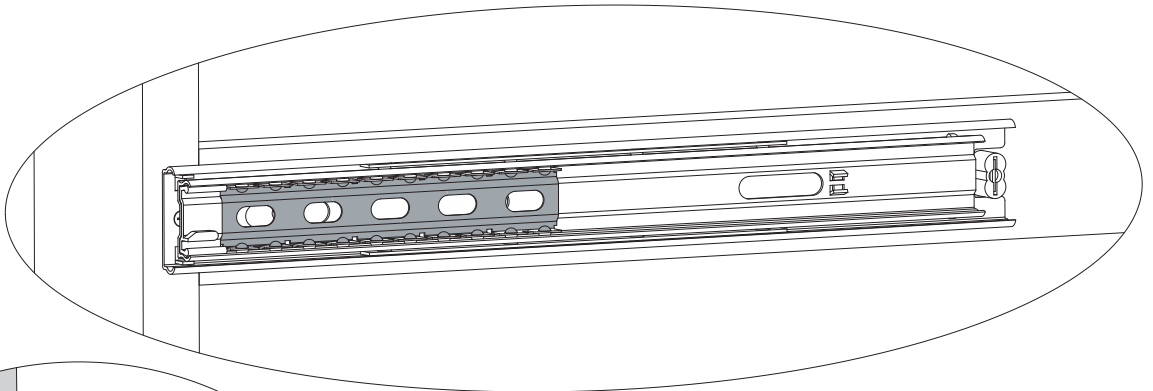
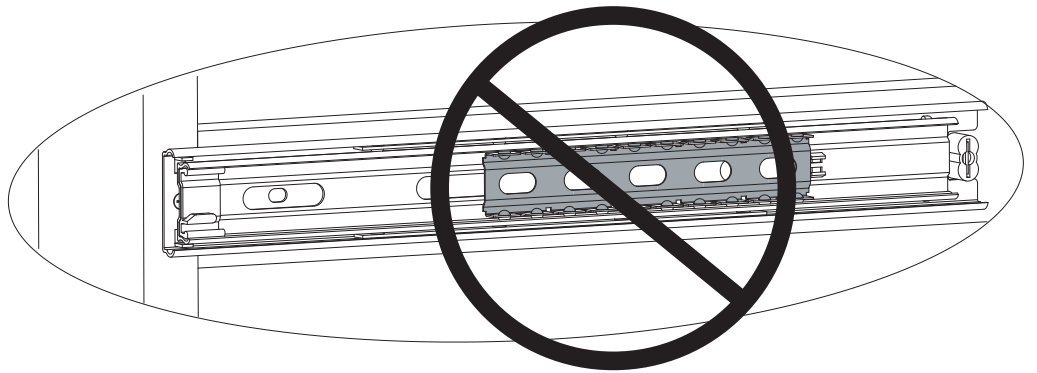

To insert drawer align male runner on drawer to female runner on case and push all the way in.

Pour insérer tiroir aligner runner homme sur le tiroir pour runner femme sur l'affaire et poussez jusqu'à ce qu'il repose.

Para insertar la gaveta alinear runner mujer en la gaveta para de hombre runner case y empuje hasta el fondo.

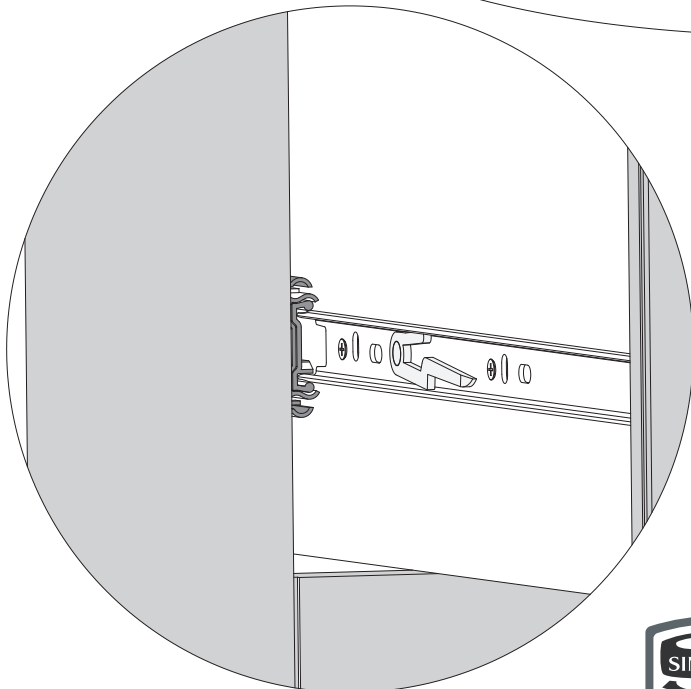



Step 16
Étape 16
Paso 16

Parts and tools required to complete step
Pièces et outils nécessaires au montage
Piezas y herramientas necesarias para completar este paso

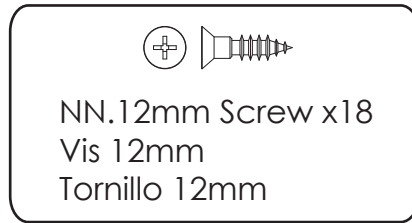

Attach (2) Drawer Guide outer pieces to each assembled drawer. There are pre-drilled holes in each drawer side.

- i) Place the end of the Drawer Guide with the tab against the Drawer front, then align the holes in the Guide to the holes in the Side, tab should remain very close to the Drawer Front.
- ii) Attach the Drawer Guide with (3) 12mm screws (Part NN). Install the screws from the Front to the Back (1st,2nd,3rd in the illustration). Tighten with a Phillips Screwdriver.
- iii) repeat with the other Drawer Side.
- iv) Repeat until all (3) Drawers are complete.

Fixer (2) parties extérieures de glissière de tiroir sur chaque tiroir monté. Des trous prépercés se trouvent sur le côté de chaque tiroir.

- i) Placer l'extrémité de la glissière de tiroir avec la patte contre l'avant du tiroir, puis aligner les trous de la glissière aux trous sur le côté. La patte doit rester très proche de l'avant du tiroir.
- ii) Fixez la glissière du tiroir à l'aide de (3) vis de 12 mm (Pièce NN) Montez les vis de l'avant vers l'arrière (1st,2nd,3rd sur l'illustration). Serrez à l'aide d'un tournevis cruciforme.
- iii) répéter cette étape avec le côté de l'autre tiroir.
- iv) Répéter jusqu'à ce que les (3) tiroirs soient montés.

Fije (2) piezas externas de guía de gaveta en cada gaveta ensamblada. Hay agujeros pre taladrados en cada costado de la gaveta.

- i) Coloque el extremo de la guía de gaveta, con la lengüeta contra la parte frontal de la gaveta, luego alinee la guía con los agujeros del costado; la lengüeta debe quedar muy cerca de la parte frontal de la gaveta.
- ii) Fije la guía de gaveta con (3) tornillos de 12 mm (Pieza NN). Instale los tornillos desde la parte frente hacia el posterior (1st,2nd,3rd en la ilustración). Apriete con un destornillador Philips.
- iii) Repita con el otro costado de la gaveta.
- iv) Repita hasta completar las (3) gavetas



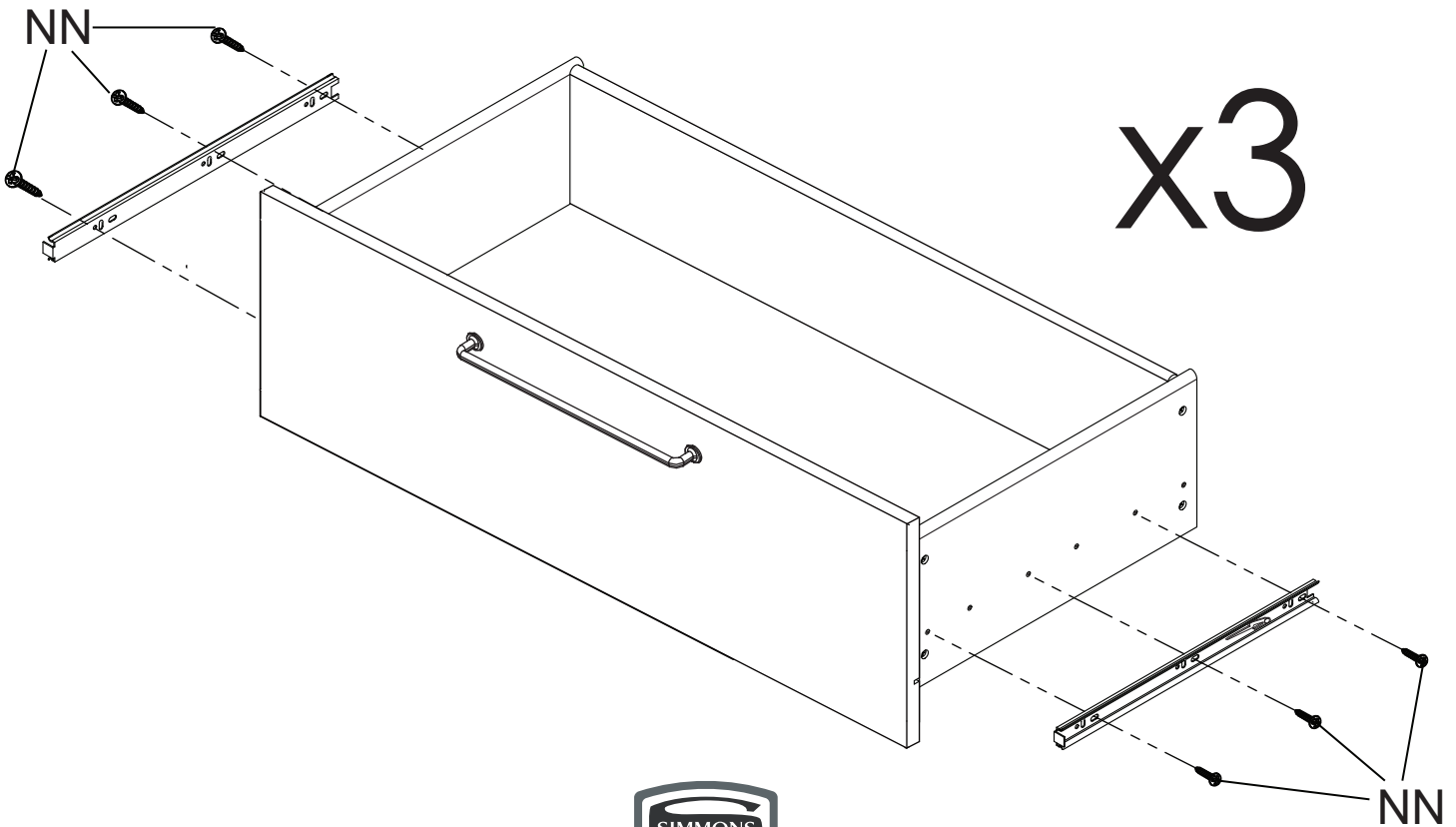
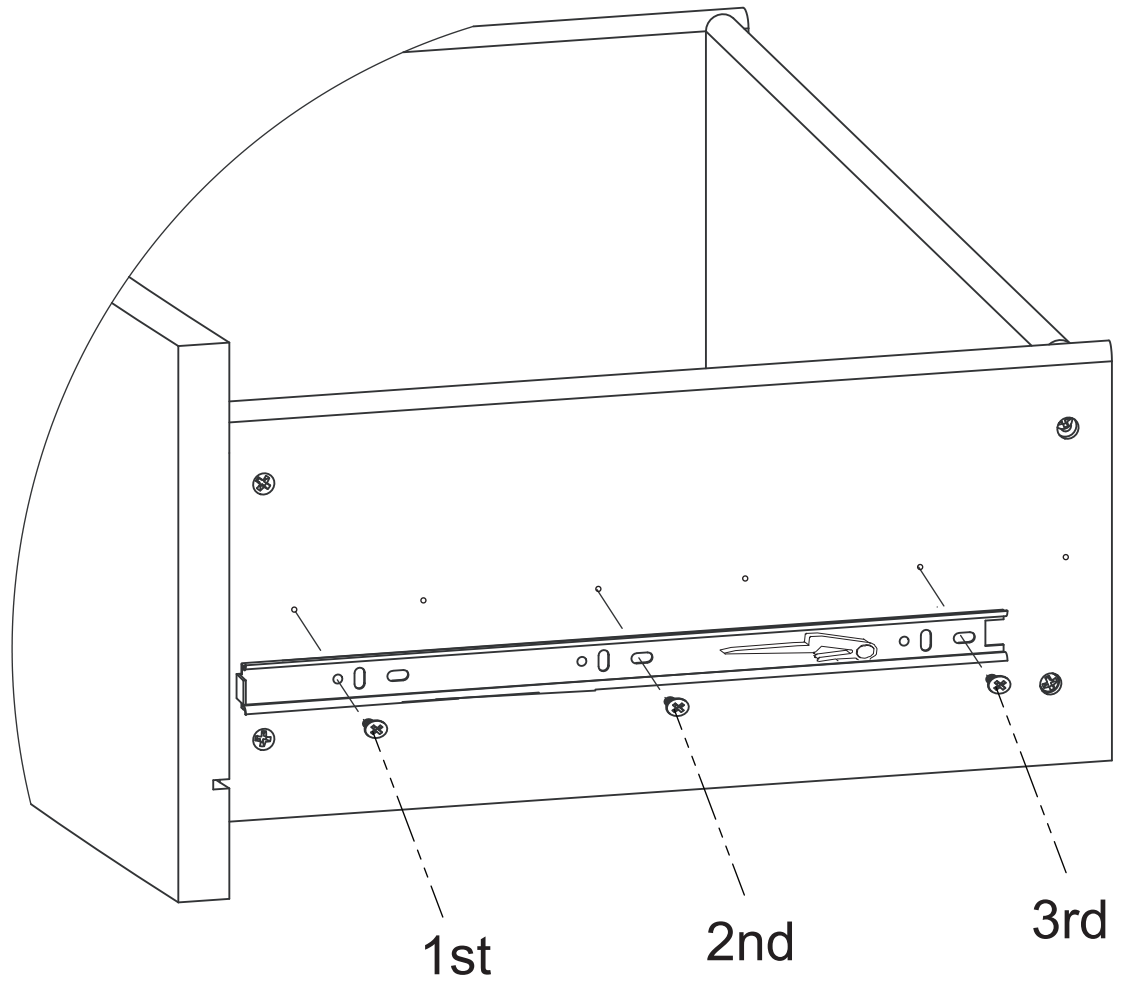



Step 17
Étape 17
Paso 17

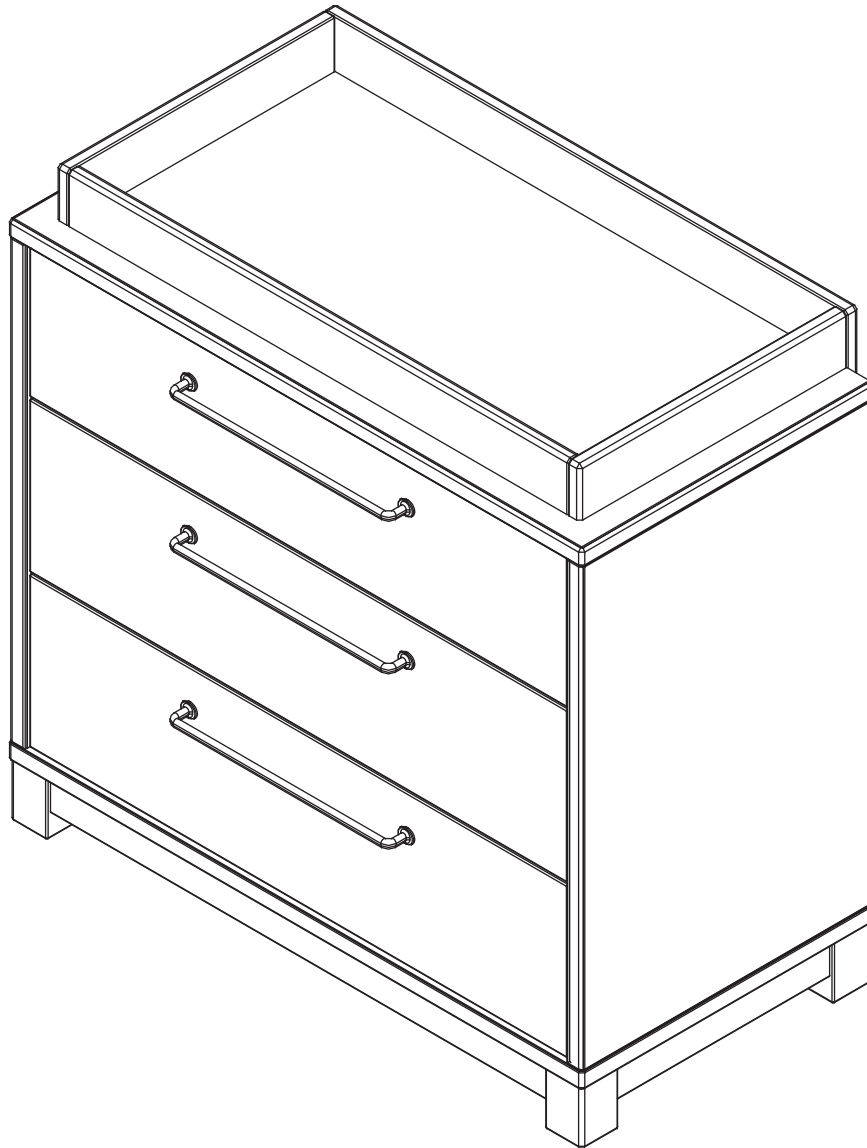

Install the drawers in the case body. Carefully align the Drawer Guides on each drawer with the Drawer Guides on the case. Push the drawer STRAIGHT in until it "clicks". Check that each side is fully secure. Open and close the drawer to ensure smooth operation. Changing the locations may improve fit or performance.

Installez les tiroirs dans le corps du boîtier. Prenez soin d'aligner les glissières de chaque tiroir avec les glissières destiroirs sur le boîtier. Poussez le tiroir HORIZONTALEMENT vers l'intérieur jusqu'à ce qu'il s'encastre. Vérifiez que chaque côté est bien fixé. Ouvrez et fermez le tiroir afin de vérifier qu'il fonctionne bien. Modifiez l'emplacement pour un meilleur ajustement ou de meilleures performances.

Instale las gavetas en el cuerpo del mueble. Alinee cuidadosamente las guías de gaveta en cada una de ellas con las guías del cuerpo del mueble. Presione la gaveta EN LÍNEA RECTA hasta que haga "clic". Revise que cada lado esté bien asegurado. Abra y cierre la gaveta para asegurarse de que funciona correctamente. Cambiar las ubicaciones podría mejorar el funcionamiento.





Consumer Experience Center

www.DeltaChildren.com

Simmons Juvenile Furniture, A division of Children's Products LLC

114 West 26th Street

New York, NY 10001

(646) 435-8727

wcs@simmonskids.com

Limited Warranty: This Delta Product is warranted to be free from defects for a period of 90 Days from the date of purchase under normal use. If a product is defective during this period, we will at our option repair or replace the defective part or product. This limited warranty extends only to the original retail purchaser and is valid only when supplied with proof of purchase, or if received as a gift, when the registration is on file with Delta. This limited warranty does not cover the following:

- Products purchased as floor models or samples.
- Items purchased on an "as-is" basis, as a second hand product, or as a resale product.
- Items purchased at a Final sale, a "Going out of Business" sale or a Liquidation sale.

This limited warranty gives you specific legal rights and you may also have other rights which vary from state to state.

Garantie Limitée: Ce Produit Delta est garanti libre de défauts pour une période de 90 jours à partir de sa date achat et dans des conditions normales d'utilisation. Si un produit se révèle défectueux pendant cette période, nous opterons soit pour une réparation, un remplacement de la pièce défectueuse ou le remplacement du produit. Cette garantie limitée se donne uniquement à l'acheteur d'origine et elle est valable seulement sur présentation d'une preuve d'achat, ou si le produit a été reçu en tant que cadeau alors il doit avoir été enregistré chez Delta. Cette garantie limitée du fabricant ne couvre pas les cas suivants :

- Produits achetés comme modèles d'exposition ou échantillons.
- Articles achetés comme « en l'état », produits d'occasion ou revente des produits.
- Articles achetés en « vente finale », ventes dans « magasins en faillite » ou ventes par liquidation.

Cette garantie limitée vous donne des droits légaux spécifiques et il se peut aussi que vous ayez d'autres droits qui varient d'un État à un autre.

Garantía Limitada: Este Producto Delta está garantizado de estar libre de defectos por un período de 90 días a partir de su adquisición, bajo uso normal. Si un producto tiene defectos durante este período, Nosotros tomaremos la opción de reparar o reemplazar la pieza defectuosa del producto. Esta garantía limitada se otorga únicamente al comprador original y es válida solamente cuando se proporciona una prueba de compra, o si el producto fue recibido como un regalo, debe haber sido registrado con Delta. Esta garantía limitada del fabricante no cubre lo siguiente:

- Productos comprados como exhibiciones de la tienda o muestras.
- Artículos comprados como "tal como está", productos de segunda mano o reventa de los productos.
- Artículos comprados como "venta final", "ventas de tiendas que están quebrando" o ventas por liquidación.

Esta garantía limitada le otorga derechos legales específicos y también puede tener otros derechos que varían de un estado a otro.

To register your product for important safety alerts and updates to your product please visit www.deltachildren.com

Pour enregistrer votre produit pour avoir les alertes de sécurité et les mises à jour de votre produit veuillez visiter www.DeltaChildren.com

Para registrar su producto para alertas importantes de seguridad y estar al tanto sobre novedades de su producto por favor visite

www.DeltaChildren.com y seleccione Product Registration.

To report a problem, please log on to www.deltachildren.com and click the Consumer Care Tab, or contact us by phone at (646) 435-8727

Pour signaler un problème, veuillez vous connecter a www.DeltaChildren.com et cliquez sur la touche Consumer Care, ou contactez nous par téléphone au (646) 435-8727

Para reportar cualquier problema, por favor entre a www.DeltaChildren.com y de clicen Servicio al cliente o contáctenos por telefono al (646) 435-8727

Date of Purchase: _____ (you should also keep your receipt)

Date d'Achat: _____ (vous devriez aussi garder votre facture d'achat)

Fecha de Compra: _____ (debe además mantener su recibo)



SAFETY LEADERS

Visit Deltachildren.Com/Pages/Leaders-In-Safety for more information

SAFE MATERIALS

Safe products start with safe materials. We test all of our products to create the safest and healthiest environment for your baby.



PRODUCTS YOU CAN TRUST

We have 8 cutting edge safety labs around the world where we test our products above and beyond the industry standards. All of our dressers are engineered to meet or exceed ASTM Furniture Safety Standards.



WE GO ABOVE & BEYOND

To protect your children, Delta Children dressers are tested to meet the requirements of the industry tip over test set forth by ASTM. For additional security, we strongly recommend that all dressers in your home be anchored; all Delta Children dressers include a wall anchor.





LEADERS EN MATIÈRE DE SÉCURITÉ

Visitez Deltachildren.Com/Pages/Leaders-In-Safety pour plus d'informations

MATÉRIAUX SURS

Les produits surs sont faits à partir de matériaux surs. Nous testons tous nos produits pour créer l'environnement le plus sûr et plus sain pour votre bébé.



DES PRODUITS FIABLES

Nous possédons 8 laboratoires de pointe en matière de sécurité où nous testons nos produits au delà des standards industriels. Toutes nos commodes sont conçues pour être aux normes selon les standards de sureté des meubles ASTM et même les dépasser.



NOUS ALLONS AU-DELÀ

Pour protéger vos enfants, les commodes de Delta Children sont testées pour satisfaire les exigences du test industriel de basculement indiqué par ASTM. Pour une sécurité additionnelle, nous recommandons fortement l'ancrage de toutes les commodes dans votre maison; toutes les commodes de Delta Children incluent une fixation pour le mur.





LÍDERES EN LA SEGURIDAD

Visite Deltachildren.Com/Pages/Leaders-In-Safety para más información

MATERIALES SEGUROS

Los productos seguros se hacen con materiales seguros. Ponemos a prueba todos nuestros productos para crear el ambiente más seguro y saludable para su bebé.



PRODUCTOS CONFIABLES

Tenemos 8 laboratorios de seguridad de alta tecnología donde probamos nuestros productos mas allá de los estándares de la industria. Todos nuestros tocadores están diseñados para cumplir o exceder los estándares de seguridad ASTM de muebles.



ESTAMOS POR ENCIMA Y MÁS ALLÁ

Para proteger a sus niños, los tocadores de Delta Children son sometidos a pruebas para que cumplan los requisitos ASTM establecidos de la industria en cuanto a volcamientos se refiere.

Para seguridad adicional, recomendamos enfáticamente que todos los tocadores de su casa estén fijos: todos los tocadores de Delta Children incluyen un anclaje de pared.





POURQUOI CHOISIR POR QUÉ ELEGIR A DELTA CHILDREN?

Visitez Deltachildren.Com/Pages/Our-Story pour plus d'information

Visita Deltachildren.Com/Pages/Our-Story para más información

<p>DELTA EN TÊTE Un enfant sur deux aux U.S.A. dort dans nos produits</p> <p>DELTA LIDERA 1 de cada 2 niños en los EE.UU duerme en nuestros productos</p>	<p>DELTA DONNE 10% de nos revenus sont dédiés à l'amélioration de la vie des enfants</p> <p>DELTA DONA 10% de nuestros ingresos está destinado a mejorar la vida de los niños</p>	<p>DELTA PREND SOIN Nous testons la conformité au-delà des standards de sécurité de l'industrie</p> <p>A DELTA LE IMPORTA Hacemos pruebas por encima de los estándares de seguridad de la industria</p>	<p>DELTA EST DÉVOUÉ familiale a été présente pour votre famille depuis 1968</p> <p>DELTA ESTÁ DEDICADA Nuestra empresa familiar ha estado siempre presente para su familia desde 1968</p>	<p>DELTA GRANDIT AVEC VOUS Nous avons des produits pour chaque âge et chaque étape</p> <p>DELTA CRECE CON USTEDES Tenemos productos para cada edad y etapa</p>	<p>Plus De 50 Ans De Sécurité, Design & Innovation</p> <p>Más De 50 Años De Seguridad, Estilo E Innovación</p>
---	---	---	---	--	--

Bienvenue dans la **FAMILLE DELTA**
Voici Notre Cadeau Pour Vous

Bienvenido a la **FAMILIA DELTA**
Aquí Está Nuestro Regalo Para Usted

10% OFF

Votre Prochain Achat Chez
Su Próxima Compra En
DeltaChildren.com

UTILISEZ LE CODE:

UTILICE EL CÓDIGO:

DELTA10

*Des exclusions s'appliquent
*Sujet à changement

*Exclusions Apply
*Subject to Change

DES PRODUITS POUR CHAQUE ÂGE ET CHAQUE ÉTAPE
PRODUCTOS PARA CADA EDAD Y ETAPA



NOTRE FAMILLE DE MARQUES SUPÉRIEURES / NUESTRA FAMILIA DE LAS MEJORES MARCAS



PLUS DE 50 ANS DE SÉCURITÉ, DESIGN & INNOVATION / MAS DE 50 ANOS DE SEGURIDAD, ESTILO E INNOVACIÓN





WHY CHOOSE DELTA CHILDREN?

Visit Deltachildren.Com/Pages/Our-Story for more information

<p>DELTA LEADS 1 Out Of 2 Children In The U.S. Sleep In Our Products</p>	<p>DELTA GIVES 10% Of Our Profits Go Toward Improving The Lives Of Children</p>	<p>DELTA CARES We Test Above & Beyond Industry Safety Standards</p>	<p>DELTA IS DEDICATED Our Family-Run Company Has Been There For Your Family Since 1968</p>	<p>DELTA GROWS WITH YOU We Have Products For Every Age And Stage</p>	<p>Over 50 Years Of Safety, Style & Innovation</p>
---	--	--	---	---	---

Welcome to the
DELTA FAMILY
Here's a Gift From Us To You

10% OFF

Your Next Purchase From
DeltaChildren.com

**USE CODE:
DELTA10**

*Exclusions Apply
*Subject to Change

PRODUCTS FOR EVERY AGE AND STAGE

 CRIBS LITS POUR BÉBÉ CUNAS	 STROLLERS ÉQUIPEMENT POUR BÉBÉ COSAS PARA BEBÉ	 GLIDERS CHAISE SILLA	 BASSINETS COUFFINS MOISÉS	 MATTRESSES MATELAS COLCHÓN	
 BABY GEAR POUSSETTES CARRIOLAS	 TODDLER BEDS LITS POUR ENFANT CAMA PARA NIÑO	 PLAYROOM FURNITURE SALLE DE JEUX CUARTO DE JUGAR	 TWIN BEDS LITS UNE PLACE CAMA SENCILLA	 BINS & ORGANIZERS PANIERES CONTENEDORES	 DRESSERS COMMODOES TOCADORES

OUR FAMILY OF TOP BRANDS



OVER 50 YEARS OF SAFETY, STYLE, AND INNOVATION

