

# First Exploration 2-in-1 Activity Walker



## INSTRUCTION MANUAL

**ADULT ASSEMBLY REQUIRED**

**32201**

**STYLES AND COLORS MAY VARY**

**REQUIRED: 2 x AA Batteries  
(not included)  
Screwdriver  
(not included)**



**⚠ WARNING:  
CHOKING HAZARD**

Adult assembly required because of small parts. Keep assembly parts out of reach of children under 3 years.

**Read all instructions BEFORE assembly and USE of product  
KEEP INSTRUCTIONS FOR FUTURE USE.**

Customer Experience Center  
phone: (646)-435-8726  
email: [gcs@DeltaChildren.com](mailto:gcs@DeltaChildren.com)



[www.DeltaChildren.com](http://www.DeltaChildren.com)

DCP-IM-03072019-V4

# Consumer Information



## WARNING

Failure to follow these warnings and instructions could result in serious injury or death.

Read all instructions before assembling unit.

**KEEP INSTRUCTIONS FOR FUTURE USE. DO NOT USE THIS UNIT IF THE INSTRUCTIONS CANNOT BE STRICTLY FOLLOWED.**

### **WARNING:**

- **NEVER** LEAVE CHILD UNATTENDED!
- **ALWAYS** KEEP CHILD IN VIEW WHILE IN WALKER.
- **NEVER** use near stairs or thresholds.
- Before each use clean friction components to maintain stopping performance.
- Strings can cause strangulation! **DO NOT** place items with a string around child's neck, such as hood strings or pacifier cords. **DO NOT** suspend strings over product or attach string to toys.
- To avoid burn injuries, always keep child away from ranges, radiators, hot liquids, space heaters, fireplaces, etc.
- To avoid drowning, never use near pools, bathtubs, etc.
- Always check that surfaces are flat and free of objects that may cause tipping over either indoors or outdoors.
- To reduce chance of child slipping out of seat, always check that both feet of child touch floor.
- Use only for children who can sit upright unassisted and weigh no more than 25 lbs.
- **NEVER** carry walker or adjust height with child in it.
- Walk behind mode is only intended for use by children 9 months - 3 years.
- Not to be used as a ride-on toy when used in the floor toy car mode.

### **STAIR HAZARD**

**AVOID SERIOUS INJURY OR DEATH BLOCK STAIRS/STEPS SECURELY BEFORE USING WALKER.**

## Care and Maintenance

---

### **Care and Maintenance:**

- Wash using mild soap and warm water only. Wipe plastic components dry and air dry seat cover.
- Keep friction components clean to maintain stopping performance



**Please DO NOT return this product to the store .**

If you experience any difficulty with assembly, missing parts or use, please DO NOT return this item to the store. Retail stores are unable to properly assist you. Contact our Customer Service Department directly for assistance  
**646-435-8726**



www.DeltaChildren.com • gcs@DeltaChildren.com  
©2019 Delta Children's Products, Inc. New York, NY 10001



## **EXTENDED WARRANTY**

**DON'T MISS YOUR CHANCE TO BE COVERED FOR ALL OF LIFES MISHAPS!**

With Delta's Extended Warranty, you're covered for mechanical failure from normal use or if your item stops working due to normal wear and tear, plus all those unexpected surprises.

## **2 YEARS OF PROTECTION**

**For Additional Information:**

**Simply visit our Website, register your product, and add the Extended Warranty**

**<https://www.deltachildren.com/pages/product-registration>**

Extended Warranty only available in the following States: Arkansas, Colorado, Delaware, District of Columbia, Georgia, Idaho, Illinois, Indiana, Iowa, Kansas, Kentucky, Louisiana, Maryland, Michigan, Mississippi, Missouri, Nebraska, Nevada, New Hampshire, New York, North Carolina, North Dakota, Pennsylvania, Rhode Island, South Dakota, Tennessee, Utah, West Virginia

# Parts

**IMPORTANT!** Please remove all parts from the package and identify them before assembly.

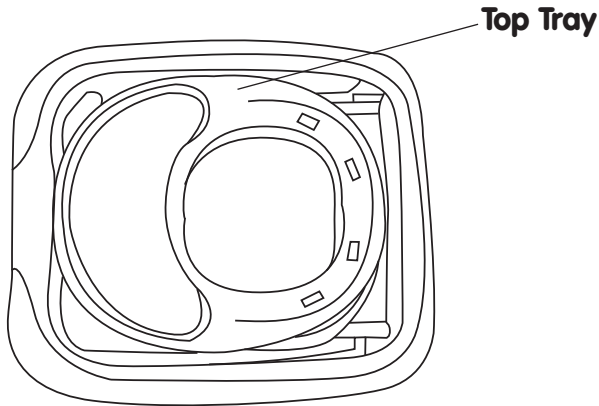

**Walker Base**

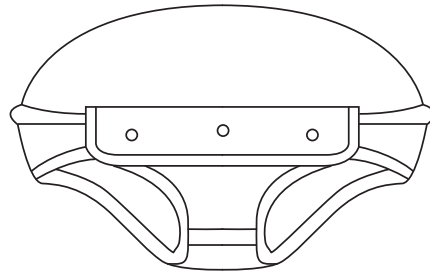

**Seat**

Part #  
2030 (Exploration) - 50326  
2031 (Orbit) - 50326

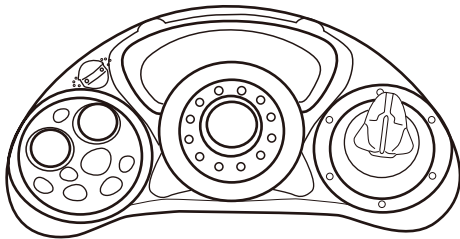

**Toy Tray**

Part #  
2030 (Exploration) - 50327  
2031 (Orbit) - 50327

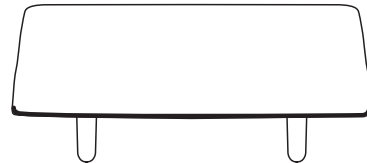

**Anti Slip Blocks x6**

Part # 50323

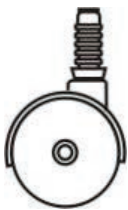

**Front Swivel Wheels x2**

Part # 50420

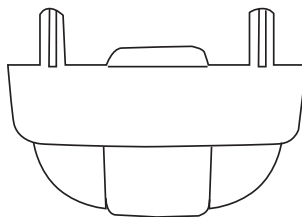

**Rear Wheels x2**

Part # 50324

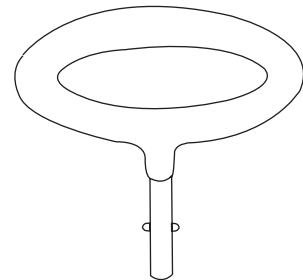

**Push Behind Handle x1**

Part #  
2030 (Exploration) - 50325  
2031 (Orbit) - 50325

# Walker Assembly

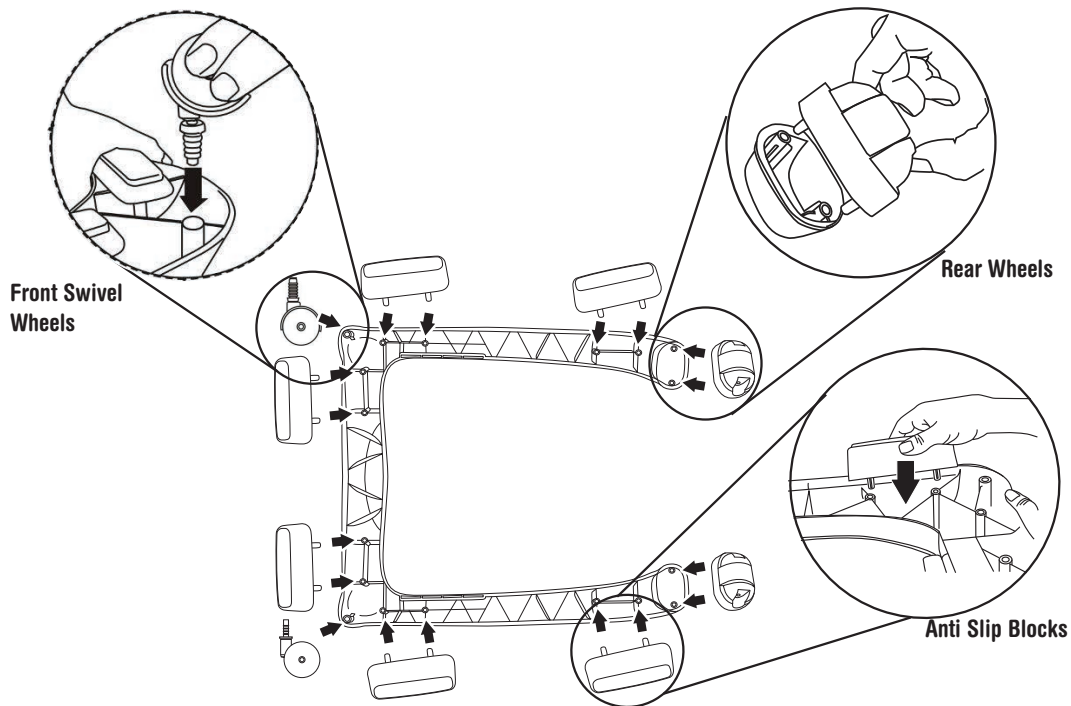

1

- Locate 2x front swivel wheels and walker base.
- Place the walker on a solid flat surface with the bottom facing upwards.
- Insert the pins of the front swivel wheels into their housings until they click into position.
- Pull upward on wheels to assure they are properly inserted.
- Locate 2x rear wheels and walker base.
- Insert the rear wheels into their housings until they click into place.
- Pull upward on wheels to assure they are properly inserted.

2

- Locate the walker base and 6x anti slip blocks.
- Insert the anti slip blocks into the receiving holes on the base.
- Push anti slip blocks all the way down until tightly secured to the walker base.
- Pull up on the anti slip blocks to assure they are properly inserted.

3

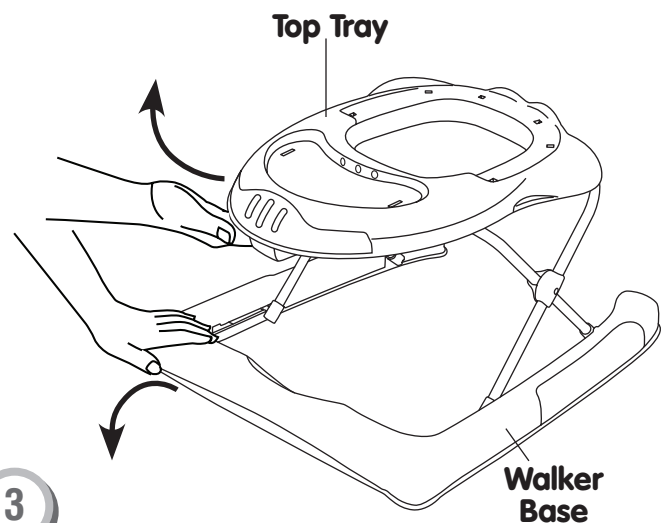

- Locate the walker base
- To raise the walker, hold the base with one hand while lifting up the top tray with the other.

# Walker Assembly

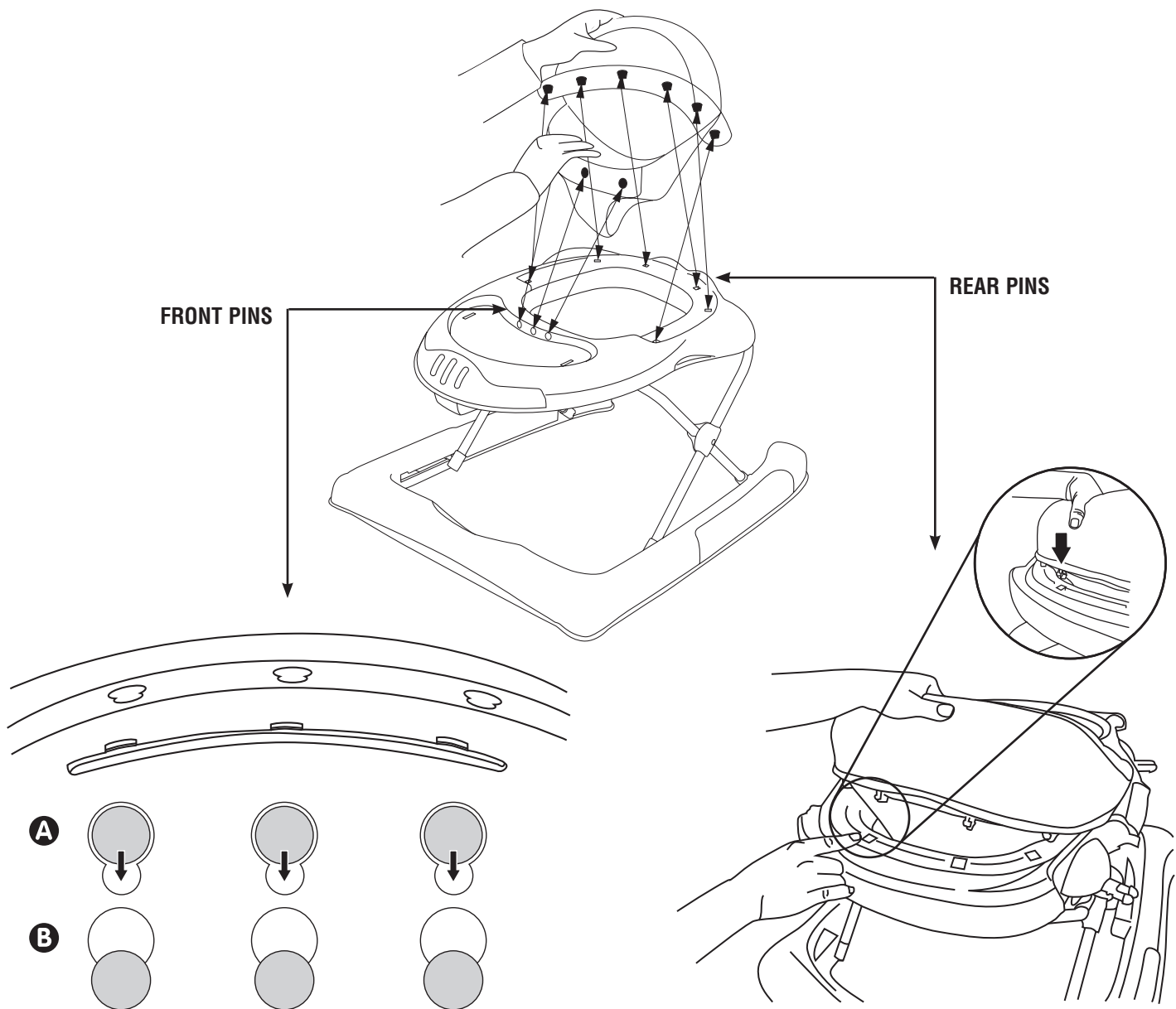

4

Attaching seat pad FRONT pins to the top tray:

- **A** Insert the 3 pins on the front of the seat pad into the receiving hole openings of the top tray front opening.
- **B** Push the front seat pins down until you hear them “click” into a lock position.

5

Attaching seat pad REAR pins to the top tray:

- Insert the 6 pins on the back of the seat pad into the receiving hole openings of the top tray back opening.
- Push the back seat pins down until you hear them “click” into a lock position.

# Battery Safety Information

**In exceptional circumstances, batteries may leak fluids that can cause a chemical burn injury or ruin your product. To avoid battery leakage:**

- Do not mix old and new batteries or batteries of different types: Alkaline, standard (carbon zinc) or rechargeable (nickel-cadmium).
- Insert batteries as indicated inside battery compartment.
- Remove batteries during long periods of non-use. Always remove exhausted batteries from the product. Dispose of batteries safely. Do not dispose of product in a fire. The batteries inside may explode or leak.
- Never short-circuit the battery terminals.
- Use only batteries of the same or equivalent type as recommended.
- Do not charge non-rechargeable batteries.
- Remove rechargeable batteries from the product before charging.
- If removable, rechargeable batteries are used, they are only to be charged under adult supervision.
- When discarding batteries, be sure to dispose of them in the proper manner, according to your state and local regulations.

## Inserting Battery

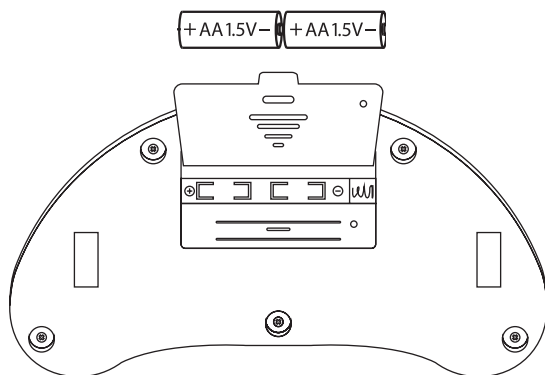
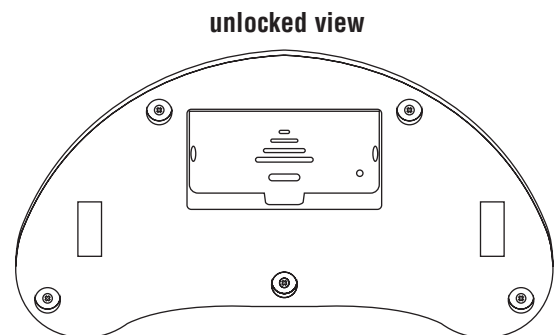
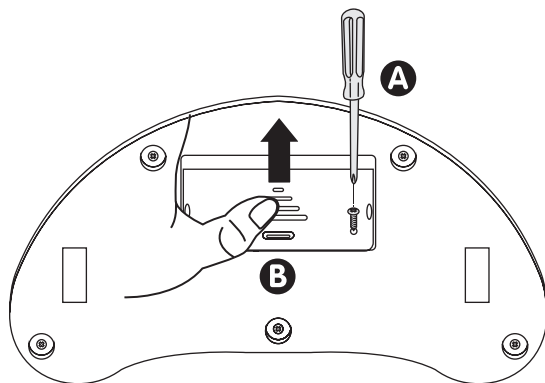

6

- Locate the battery cover on bottom of toy tray.
- Use a Phillips head screw driver to **A** unfasten the battery cover.
- Slide upward to release top **B**
- **B** Lift cover to open battery compartment.
- **C** Insert AA batteries (x2) as shown in the picture.
- **D** Close battery cover. Use a Phillips head screw driver to fasten the battery cover closed.



## Walker Assembly

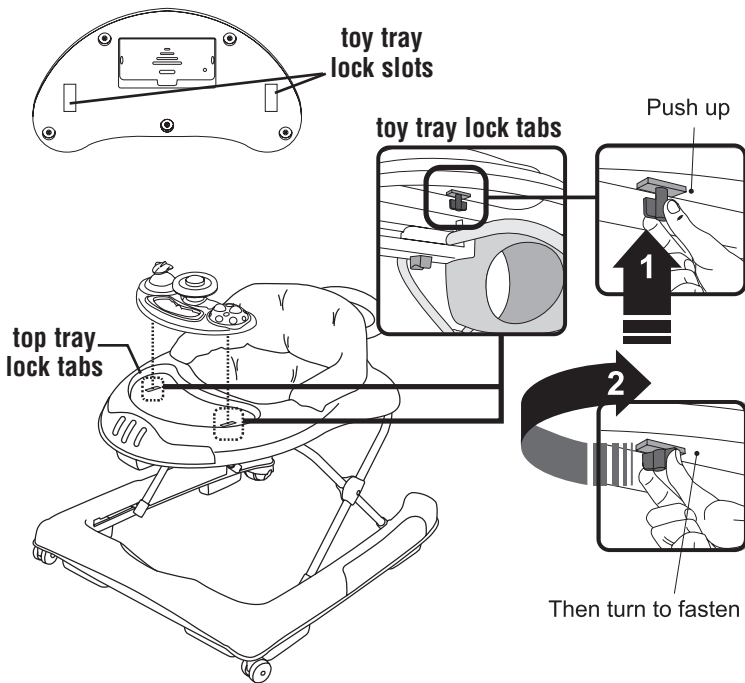

7

- On the bottom of the toy tray locate the lock slots and lock tabs on top tray.
- Align toy tray to top tray insert. While holding down the toy tray **1** push up the top tray lock tabs and **2** turn to fasten.

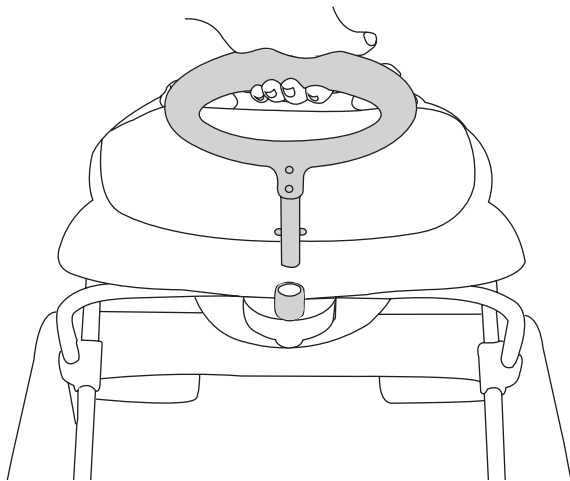

8

- Locate push behind handle.
- Place the push behind handle into the back of the walker housing and push down until the push pins "CLICK" into a fully locked position.
- To release push behind handle, press the push pins inward on both sides and lift upward to fully remove.

## Adjust the Height and Fold

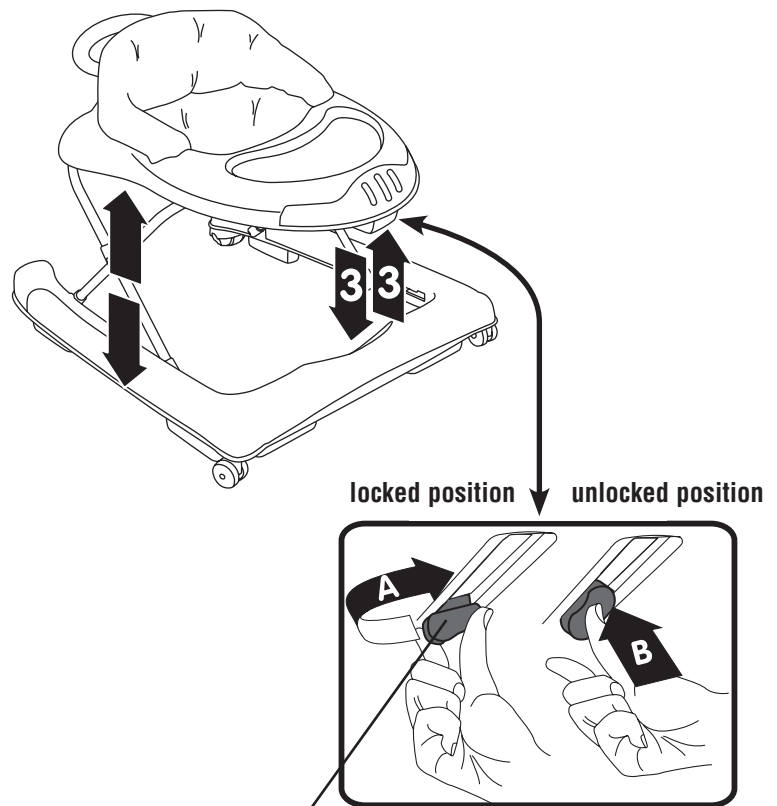

9

SAFETY BUTTON

To adjust the height and fold the walker, locate slider joint beneath the top tray

### WARNING

DO NOT adjust the seat height with the baby in the walker. Remove the baby from the walker when adjusting the seat height.

- Turn the safety button lengthwise **A** and press the button until the mechanism is released. With the button still pressed in, select new height. 3 different height positions are available.
- When the new position has been selected, **B** release the button and check it has turned 90 degrees back to original position.
- When folding the walker, turn to unlock as shown in step push the button to release and hold the button down as shown in step **B**. Carefully lower the walker into complete folded position.



Delta Children's Products Corp.

114 West 26<sup>th</sup> Street  
New York, NY 10001  
646-435-8726

www.DeltaChildren.com









