

Read all instructions before assembly and use.

KEEP INSTRUCTIONS FOR FUTURE USE.

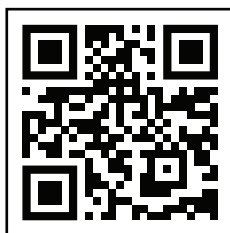

To Make Assembly Even Easier Watch Video Here!



For Questions or to Contact Us:

DeltaChildren.com/Help

If unable to access website, please email wcs@DeltaChildren.com

Expect longer response times via email.



Style #: _____
 Lot: _____
REV
 Date: _____

Before contacting Delta Consumer Experience Center please ensure this information matches the information found on the label on the Back Panel.



ADULT ASSEMBLY REQUIRED

Due to the presence of small parts during assembly, keep out of reach of children until assembly is complete.

This product is not intended for institutional or commercial use.

Lea todas las instrucciones antes de ensamblar y usar.

MANTENGA LAS INSTRUCCIONES PARA SU USO FUTURO.



Para facilitar más aun el ensamblaje ver el video aquí

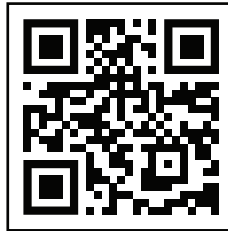

Para preguntar o para contactarnos :

DeltaChildren.com/Help

Si no puede acceder el sitio web, por favor envíenos un email a wcs@DeltaChildren.com

El tiempo de espera para respuestas será más largo por email.



DEBE SER ENSAMBLADO POR UN ADULTO

Debido a la presencia de piezas pequeñas durante el ensamblaje, mantenga fuera del alcance de los niños hasta que complete el ensamblaje.

Antes de contactar el Centro de Experiencia del Consumidor de Delta por favor asegúrese de que la información de la primera página coincida con la información que se encuentra en la etiqueta ubicada en el panel trasero.

Este producto no está hecho para uso institucional o comercial.

BABY SAFE SLEEP TIPS

Visit Deltachildren.Com/Pages/Crib-Safety-Tips for more information



Read all warnings and follow all instructions.



DO NOT place any items in the crib.



The safest place for your baby to sleep is in a JPMA Certified crib.



Pillows and blankets have caused infants to suffocate, **NEVER** use in a crib.



Your baby should sleep on a firm mattress.



NEVER place the crib near a window or any wall hangings.



Adult beds are not safe for babies: **NEVER** co-sleep.



Missing or broken parts, any questions?
www.DeltaChildren.com/Help



AAP RECOMMENDS:

Always lay your baby on its back to sleep.

Consult your doctor.

FURNITURE SAFETY TIPS

Visit Deltachildren.Com/Pages/Leaders-In-Safety for more information

SERIOUS OR FATAL CRUSHING INJURIES
CAN OCCUR FROM FURNITURE TIP-OVER.



Read all warnings and follow all instructions.



NEVER open more than one drawer at a time.



ALWAYS use provided tipover restraints.



DO NOT leave drawers open when not in use.



DO NOT set TV's or other heavy objects on the top of bedroom or nursery furniture.



NEVER allow children to climb or hang on drawers, doors, or shelves.



Place heaviest items in the lowest drawers.



Missing or broken parts, any questions?
www.DeltaChildren.com/Help

CONSEJOS PARA UN SUEÑO SEGURO PARA LOS BEBÉS

Visite Deltachildren.Com/Pages/Crib-Safety-Tips para obtener más información



Lea todas las advertencias y siga todas las instrucciones.



NO coloque artículos en la cuna.



El lugar más seguro para que su bebé duerma es una cuna con certificación JPMA.



Las almohadas y frazadas han provocado asfixia en menores; por lo tanto, **JAMÁS** se deben utilizar en una cuna.

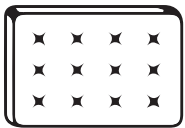

Su bebé debe dormir sobre un colchón firme.



JAMÁS coloque la cuna cerca de una ventana o elementos colgados en las paredes.



Las camas para adultos no son seguras para los bebés: **JAMÁS** duerma con ellos.



¿Le faltan piezas o vienen rotas?
www.DeltaChildren.com/Help



APP RECOMIENDA:

Haga que su bebé duerma siempre boca arriba.

Consulte a su médico.

CONSEJOS DE SEGURIDAD SOBRE MUEBLES

Visite Deltachildren.Com/Pages/Leaders-In-Safety para obtener más información

PUEDEN PRODUCIRSE LESIONES GRAVES O MORTALES
POR APLASTAMIENTO AL VOLCARSE MUEBLES.



Lea todas las advertencias y siga todas las instrucciones.

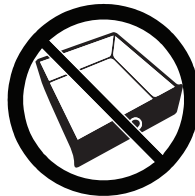

NUNCA abra más de un cajón al mismo tiempo.



Utilice **SIEMPRE** las retenciones contra volcamiento incluidas



NO DEJE cajones abiertos si no los está utilizando.



NO posicione televisores u otros objetos pesados sobre la cama o muebles para infantes.



NUNCA permita que los niños trepen sobre cajones, puertas o baldas de estantería ni que se cuelguen de ellos.



Coloque los artículos de mayor peso en los cajones inferiores.



¿Le faltan piezas o vienen rotas?
www.DeltaChildren.com/Help

SAVE BIG WITH DELTA CHILDREN

Visit **Deltachildren.com** To Start Shopping

Welcome to the
DELTA FAMILY
Here's a Gift From Us To You

10% OFF

Your Next Purchase From
DeltaChildren.com

USE CODE:
DELTA10

*Exclusions Apply
*Subject to Change

REVIEW TO WIN \$2500

RULES TO ENTER



"We LOVE, LOVE, LOVE this crib"

My husband was impressed with the directions and organization of the hardware package. He easily assembled this crib in an hour without any help. It's very sturdy and we like that it has adjustable levels for the mattress height. To top it all off, it's so incredibly darling!!!

- 1** **WRITE A REVIEW** for this product on the store's website from where it was purchased
- 2** **TAKE A SCREENSHOT** of your review and upload it to www.DeltaChildren.com/Review
- 3** **IT'S THAT EASY!** Upon submission, you'll be instantly **ENTERED TO WIN \$2,500**

FOLLOW US FOR MORE CHANCES TO WIN

   
@deltachildren

SCAN HERE



For more
information &
to see all of
our products

AHORRE MUCHO CON DELTA CHILDREN

Visita **Deltachildren.com** Para Comenzar A Comprar

Bienvenido a la
FAMILIA DELTA

Aquí Está Nuestro Regalo
Para Usted

**10%
OFF**

Su Próxima Compra En
DeltaChildren.com

UTILICE EL CÓDIGO:
DELTA10

*Exclusions Apply
*Subject to Change

CALIFIQUE EL PRODUCTO PARA **GANAR \$2500**

REGLAS PARA PARTICIPAR



- 1 **CALIFIQUE EL PRODUCTO** en la página web de la tienda donde haya sido comprado
- 2 **HAGA UNA CAPTURA DE PANTALLA** de su calificación y cárguela a la pagina www.DeltaChildren.com/Review
- 3 **ES ASÍ DE FÁCIL!** En cuanto lo envíe ya estará instantáneamente **PARTICIPANDO PARA GANAR \$2.500**

SÍGANOS PARA TENER MAS CHANCES DE GANAR

@deltachildren

ESCANEE AQUÍ



Para más
información
y para ver todos
nuestros productos

⚠ WARNING

Children have died from furniture tipover. To reduce the risk of furniture tipover:

- ALWAYS install tipover restraint provided.
- NEVER put a TV on this product.
- NEVER allow children to stand, climb or hang on drawers, doors, or shelves.
- NEVER open more than one drawer at a time.
- Place heaviest items in the lowest drawers.

**NOTES ON ASSEMBLY:**

- During the assembly process whenever using screws or bolts, check each by placing the screw/bolt on the diagram of the item which is drawn actual size and design. Be sure to use the proper size and shape specified in the instructions.
- To assemble this unit you may be required to place the unit on it's side and face. It is strongly recommended that assembly is done on a soft, non-abrasive surface to avoid damaging the finish.

NOTES ON USE:

Keep children and others safe by following these simple rules:

- **Do not** allow any child to play on furniture
- **Do not** allow climbing on any piece of furniture.
- **Do not** allow hanging from any piece of furniture.
- Always monitor your child's activity when in the nursery.

NOTES ON CARE AND MAINTENANCE:

- **Do not** scratch or chip the finish.
- Inspect the product periodically, contact Delta Children's Products for replacement parts or questions.
- **Do not** store the product or any parts in extreme temperatures and conditions such as a hot attic or a damp, cold basement. These extremes can cause a loss of structural integrity.
- To preserve the luster of the high quality finish on your product, it is recommended to place a doily or felt pad under any items you place on the finish.
- Clean with a damp cloth, then a dry cloth to preserve the original luster and beauty of this fine finish.
- Do not** use abrasive chemicals.
- Do not** spray cleaners directly onto furniture.
- Lift slightly when moving on carpeting to prevent leg breakage.
- Use of a vaporizer near furniture will cause wood to swell and finish to peel.

▲ ADVERTENCIA



Han muerto niños debido a volcaduras de muebles. Para prevenir volcaduras:

- Instalar SIEMPRE el dispositivo anti-volcaduras incluido.
- No colocar NUNCA un televisor en este producto.
- Nunca permita que los niños trepen sobre cajones, puertas o baldas de estantería ni que se cuelguen de ellos.
- Nunca abra más de un cajón al mismo tiempo.
- Coloque los artículos de mayor peso en los cajones inferiores.



INFORMACIÓN SOBRE EL MONTAJE:

- Durante el proceso de montaje, ya utilice pernos o tornillos, compruebe cada uno de ellos colocando el perno/tornillo en el diagrama del artículo donde está dibujado el tamaño y el diseño real. Asegúrese de que utiliza el tamaño y la forma adecuada que especifican las instrucciones.
- Para montar esta unidad, puede que se le solicite que coloque la unidad de lado y de cara. Se recomienda encarecidamente que realice el montaje sobre una superficie no abrasiva (Como la envoltura de embalaje de espuma) para evitar dañar el acabado.

INFORMACIÓN SOBRE EL USO:

Mantenga a los niños y otras personas a salvo siguiendo estas sencillas reglas:

- **No permita** que ningún niño juegue sobre muebles.
- **No permita** que nadie trepe sobre un mueble.
- **No permita** que nadie se cuelgue de un mueble.
- Vigile siempre la actividad de su hijo cuando se encuentre en su cuarto.

NOTAS SOBRE SU CUIDADO Y MANTENIMIENTO:

- **No** arañe ni desconche el acabado.
- Inspeccione el producto con regularidad, póngase en contacto con Delta Children's Products para el recambio de partes o para formular preguntas.
- **No** guarde el producto ni ninguna de sus partes a temperaturas ni en condiciones extremas como un ático caluroso o un sótano húmedo y frío. Estos extremos pueden provocar una pérdida de integridad estructural.
- Para preservar el brillo del acabado de alta calidad que recubre su producto, se recomienda que coloque un paño o una almohadilla de fieltro debajo de cualquier objeto que coloque sobre el acabado.
- Límpielo con un trapo húmedo y luego con uno seco para preservar el brillo y la belleza originales de este fino acabado.
- No** utilice productos químicos abrasivos.
- No** pulverice limpiadores directamente sobre el mueble.
- Elévelo ligeramente cuando lo mueva sobre alfombras o moqueta para evitar que se rompan las patas.
- El uso de vaporizadores cerca de muebles puede provocar que la madera se hinche y acabe desconchándose.

PARTS: MAKE SURE THAT ALL PRE-ASSEMBLED PARTS ARE TIGHT
PIEZAS: ASEGÚRESE DE QUE TODAS LAS PIEZAS PRE-ENSAMBLADAS ESTÁN BIEN APRETADAS.

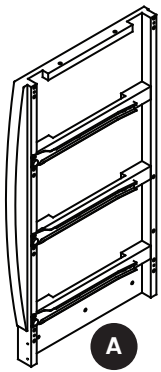

A
 Left Side x1
 Lado izquierdo
 # 21718

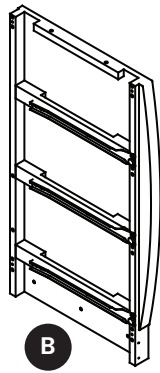

B
 Right Side x1
 Lado derecho
 # 21719

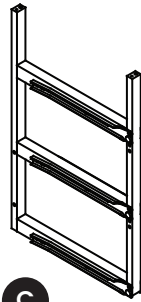

C
 Divider Frame x1
 Marco divisor
 # 21720

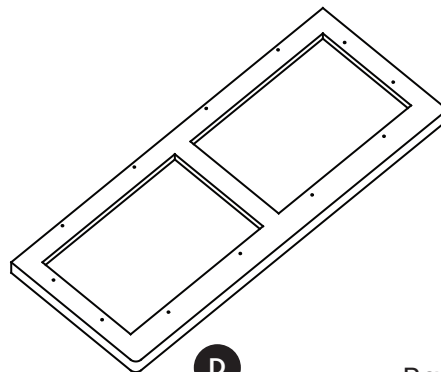

D
 Top Panel x1
 Panel superior
 # 21730

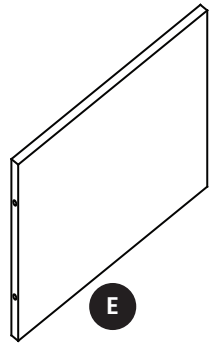

E
 Back Weight x2
 Peso trasero
 #21726

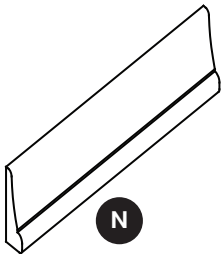

N
 Side Molding x2
 Moldura lateral
 # 21729

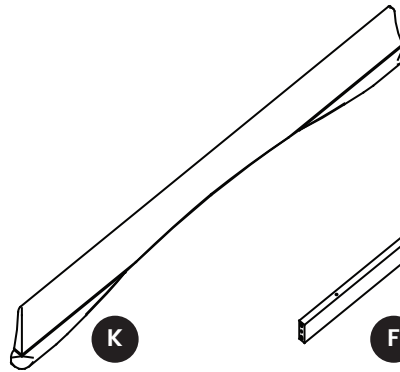

K
 Front Molding x1
 Moldura frontal
 # 21728

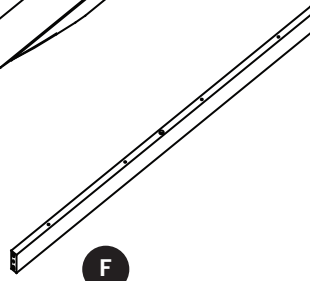

F
 Top Front Rail x1
 Riel frontal superior
 #40012

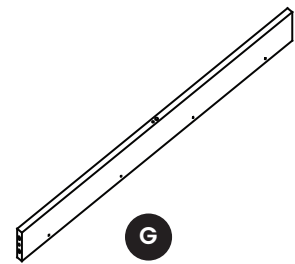

G
 Bottom Front Rail x1
 Riel frontal inferior
 #40014

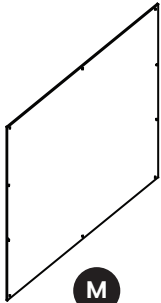

M
 Back Panel x2
 Panel trasero
 #21727



S
 Left Drawer Side x6
 lado izquierdo de la gaveta
 # 29934

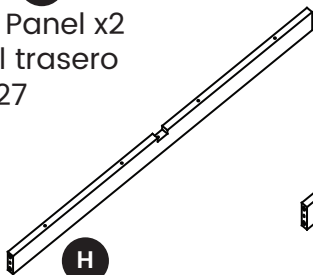

H
 Top Back Rail x1
 Riel trasero superior
 # 40013

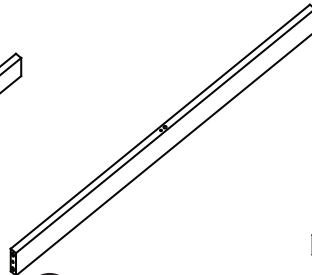

J
 Bottom Back Rail x1
 Riel trasero inferior
 #40015

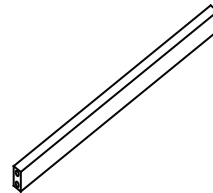

L
 Drawer Rail x4
 Riel de la gaveta
 #21725



T
 Right Drawer Side x6
 lado derecho de la gaveta
 # 29935



U
 Drawer Bottom x6
 Fondo de la gaveta
 # 29937



R
 Drawer Back x6
 Trasera de la gaveta
 # 29936

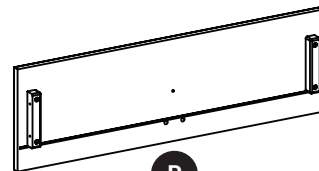

P
 Drawer Front x6
 Parte frontal de
 la gaveta
 # 29939



V
 Drawer Support x6
 Soporte de la gaveta
 #29938

PARTS: HARDWARE KITS PART#29940
PIEZAS: EL KIT DE HERRAMIENTAS - PIEZA #29940

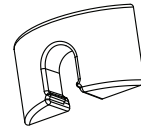

MM Crescent Washer x8
 Arandela de Media Luna

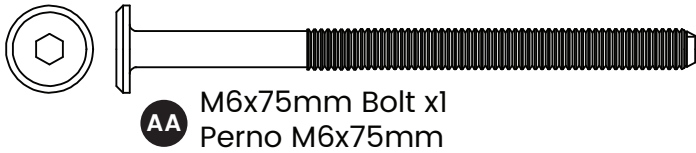

AA M6x75mm Bolt x1
 Perno M6x75mm

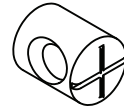

LL Plastic Barrel Nut x30
 Tuerca cilíndrica plástica



BB M6x60mm Bolt x8
 Perno M6x60mm

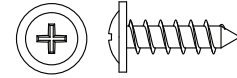

HH 16mm Back Panel Screw x20
 Tornillo 16mm de Panel Trasero



CC M6x55mm Bolt x1
 Perno M6x55mm

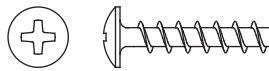

NN 20mm Screw x24
 Tornillo 20mm

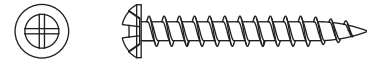

GG 30mm Screw x14
 Tornillo 30mm



DD M6x45mm Bolt x10
 Perno M6x45mm

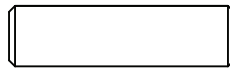

KK Φ 8x30mm Wood Dowel x46
 Pasador de madera Φ 8x30mm

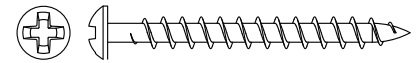

FF 40mm Screw x30
 Tornillo 40mm

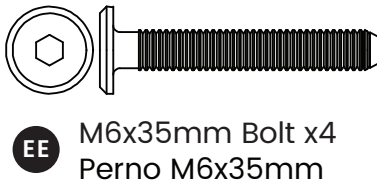

EE M6x35mm Bolt x4
 Perno M6x35mm

PP Knob / Perilla x6
 #29942

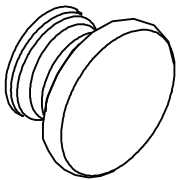

PP1 Knob
 Perilla



PP2 Knob Screw
 Tornillo para Perilla



ZZ Wall Strap x1
 Abrazadera

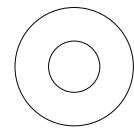

TT Washer x2
 Arandela

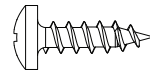

YY Short Screw x1
 Tornillo corto

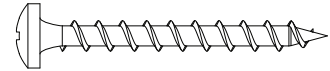

XX Long Screw x1
 Tornillo Largo

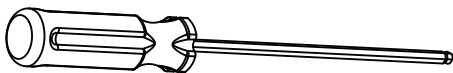

M4 Ballend Screwdriver
 destornillador M4 con cabeza de bola



Phillips Screwdriver – Not included
 Destornillidor Phillips – no incluido



M4 Allen Wrench
 Llave Allen M4

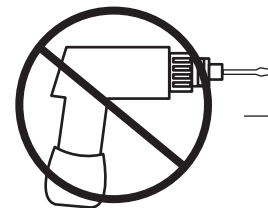

No drills necessary.
 Do not use power screwdriver.

No hace falta taladrar.
 No utilice destornilladores eléctricos

Hardware System - Review Before Assembly

Revise Antes De Armar- Elementos De Fijacion Y Ensamble

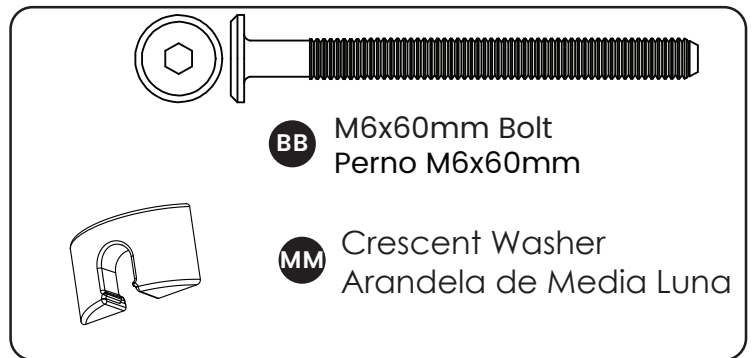
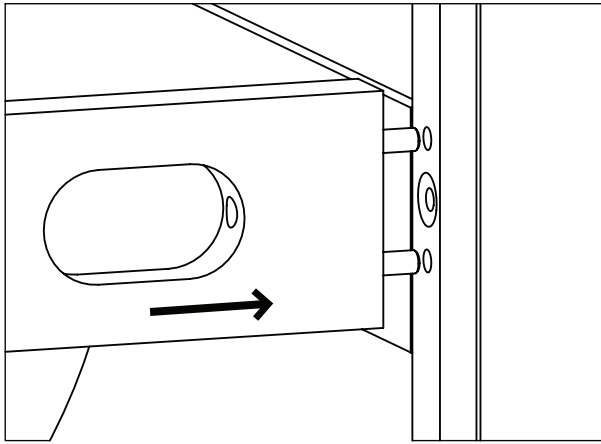

1. Insert the Dowels in the Rail into the holes in the Post.

1. Inserte los pasadores del Riel en los agujeros del Poste.

2. Insert the Bolt into the slot. Turn clockwise with fingers or the Ball End Screwdriver provided. DO NOT fully tighten, leave 1/2" (12mm) exposed.

2. Inserte el perno en la ranura. Gírelo en el sentido de las agujas del reloj con los dedos o con el destornillador con cabeza de bola. NO lo apriete del todo, deje 1/2" (12 mm) fuera.

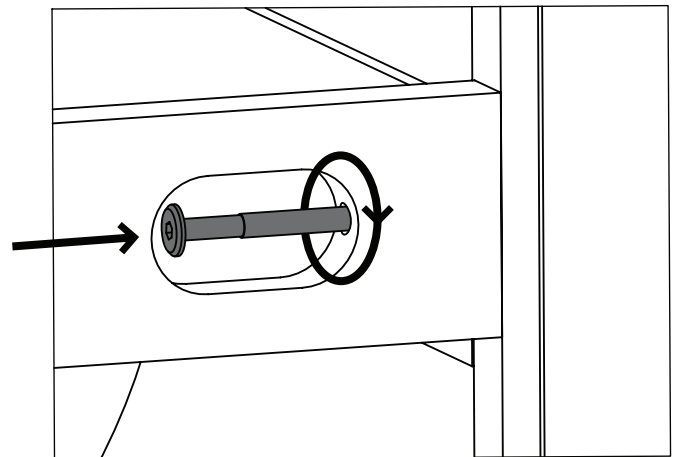

3. Slide the Crescent Washer over the exposed bolt, behind the head of the bolt.

3. Abraza la parte del Perno que quedó fuera, debajo de la cabeza del mismo, con la Arandela de media luna.

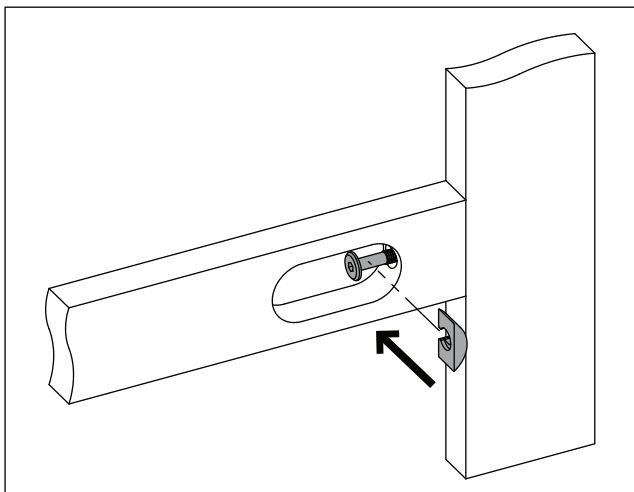

Install (1) bolt and (1) crescent washer at a time. Tighten until it looks like the picture.

Instale (1) perno y (1) Arandela de media luna al mismo tiempo. Apriételos hasta que quede como en la ilustración.

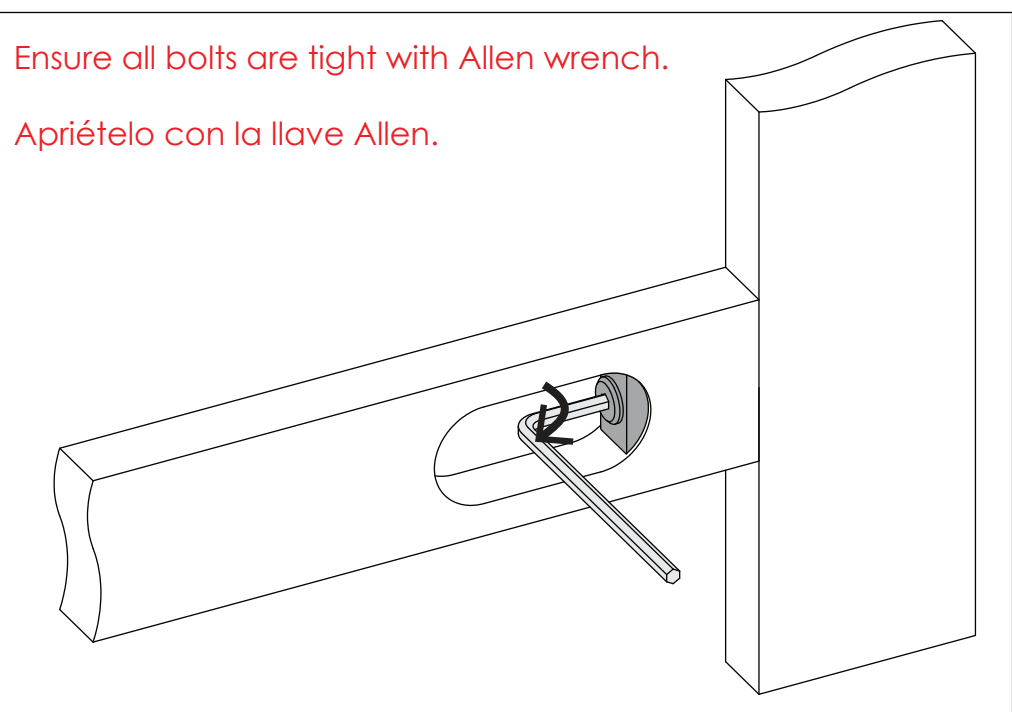
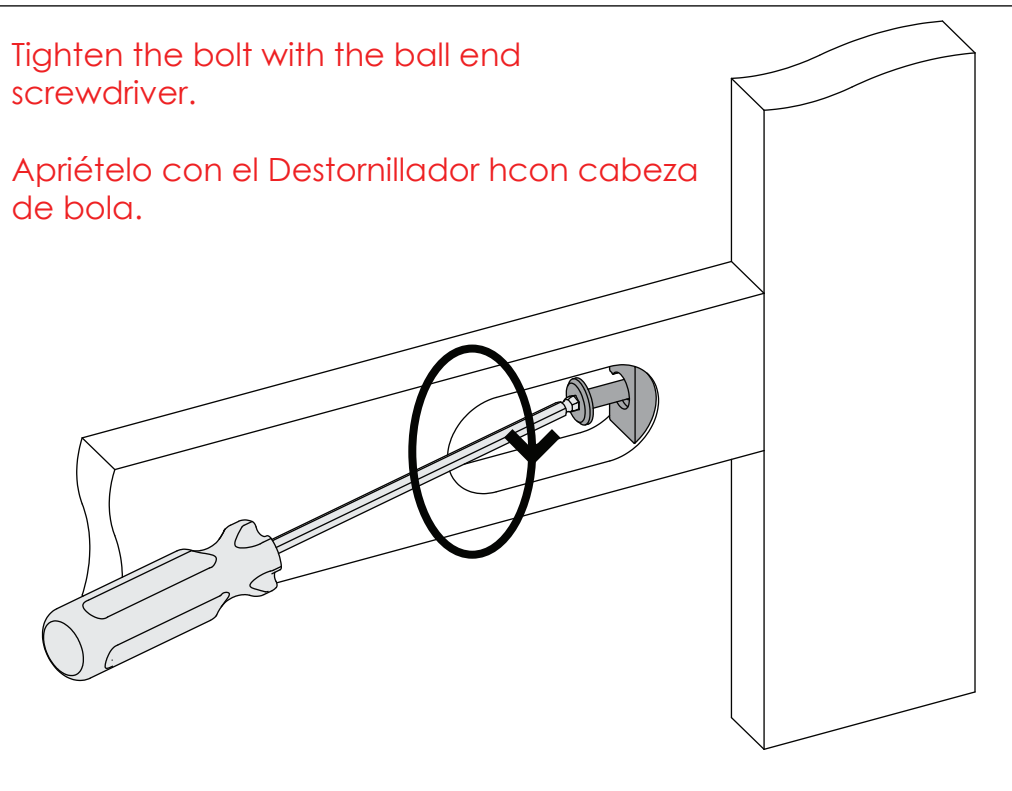

STEP 1
PASO 1

Parts and tools required to complete step
Piezas y herramientas necesarias para completar este paso

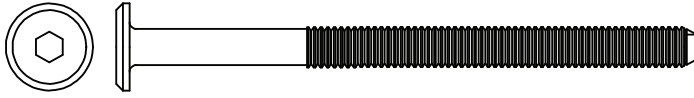

AA M6x75mm Bolt x1
Perno M6x75mm



KK Φ 8x30mm Wood Dowel x4
Pasador de madera Φ 8x30mm



CC M6x55mm Bolt x1
Perno M6x55mm

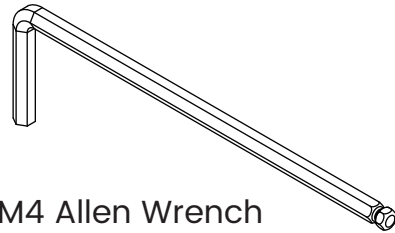

M4 Allen Wrench
Llave Allen M4



DD M6x45mm Bolt x2
Perno M6x45mm

Attach Top Front Rail (Part F), Bottom Front Rail (Part G), Top Back Rail (Part H), Bottom Back Rail (Part J) to Divide Frame (Part C) using (4) dowels (Part KK), (1) 75mm Bolt (Part AA), (2) 45mm Bolt (Part DD) and (1) 65mm Bolt (Part CC). Tighten all bolts with the Allen Wrench.

Una el Riel frontal superior (Parte F), el Riel frontal inferior (Parte G), el Riel trasero superior (Parte H), el Riel trasero inferior (Parte J) al Marco divisor (Parte C). Con ayuda de (4) Pasador de Madera (Parte KK), (1) perno de 75mm (Parte AA), (2) pernos de 45mm (Parte DD) de (1) perno de 65mm (Parte CC). Apriete todos los pernos con la llave Allen

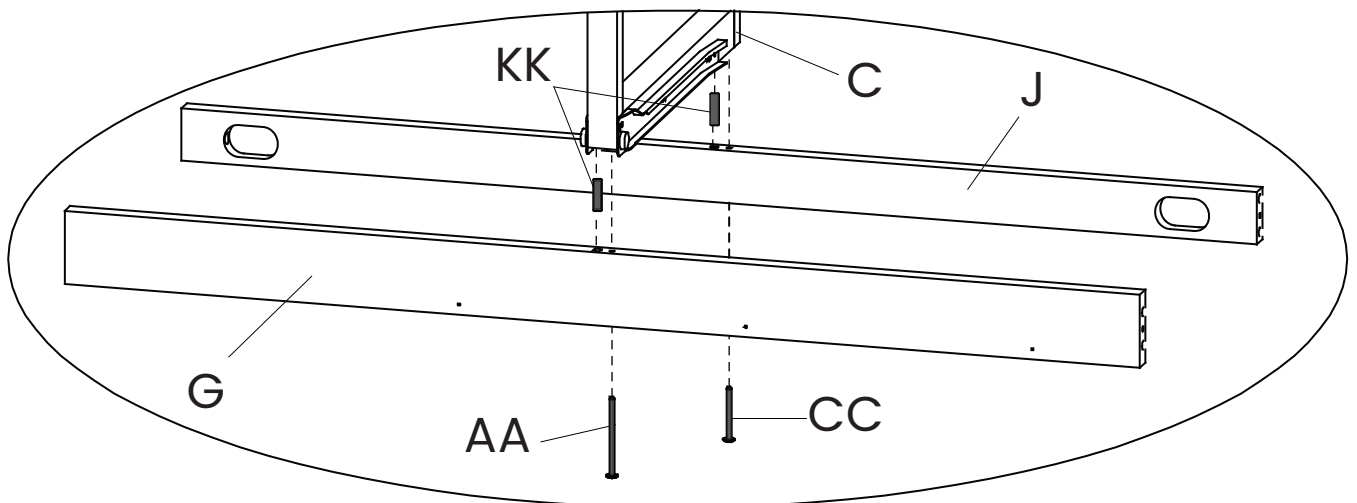
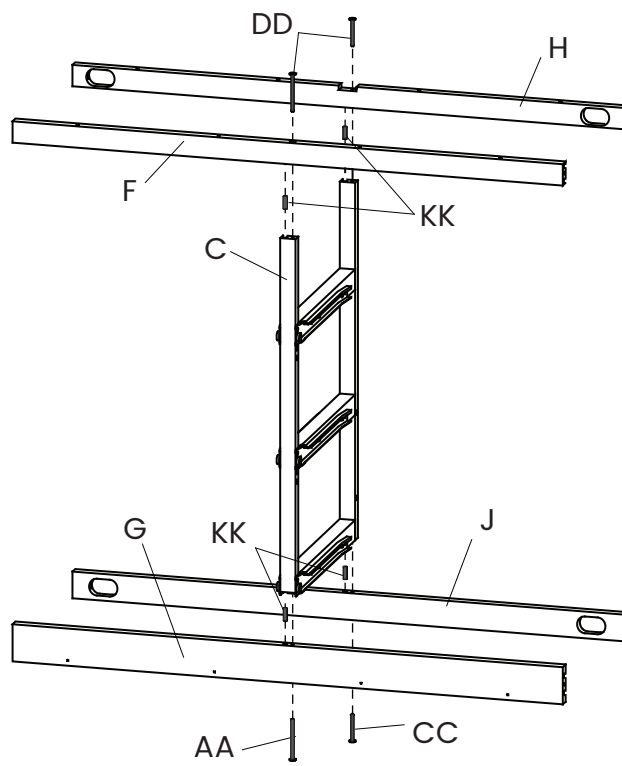
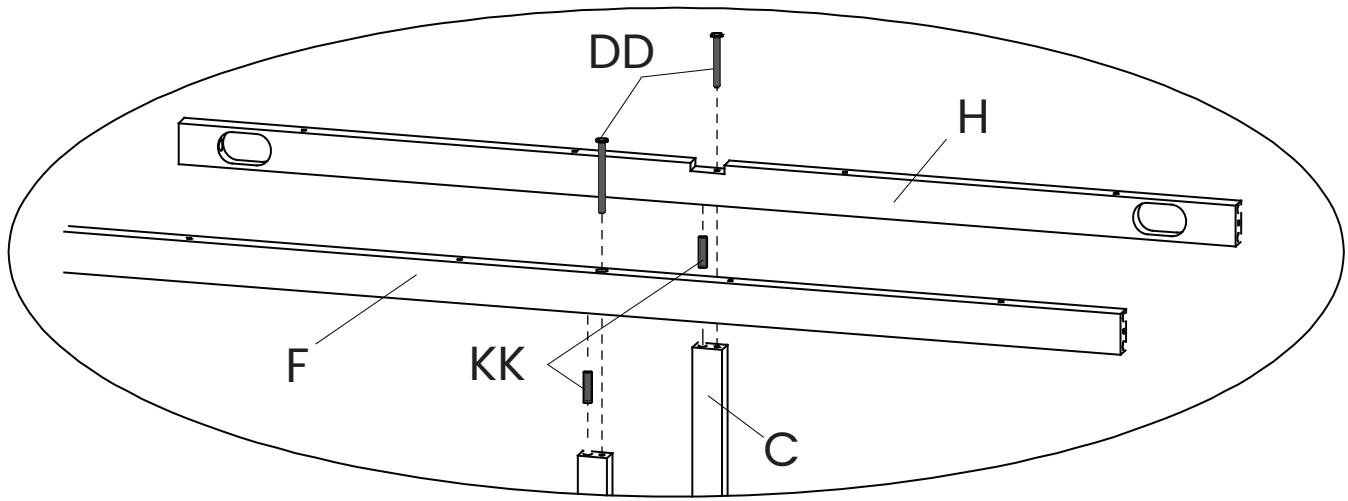

STEP 2
PASO 2

Parts and tools required to complete step

Piezas y herramientas necesarias para completar este paso

**KK**

Φ8x30mm Wood Dowel x6
Pasador de madera Φ8x30mm

Attach (1) Back Weight (Part E), (2) Drawer Rails (Part L) to the assembly from Step 1 using (6) 30mm Wood Dowels (Part KK).

Fije (1) peso trasero (Pieza E) y (2) rieles de gaveta (Pieza L) en el ensamblaje del Paso 1 utilizando (6) Pasadores de madera 30mm (Pieza KK).

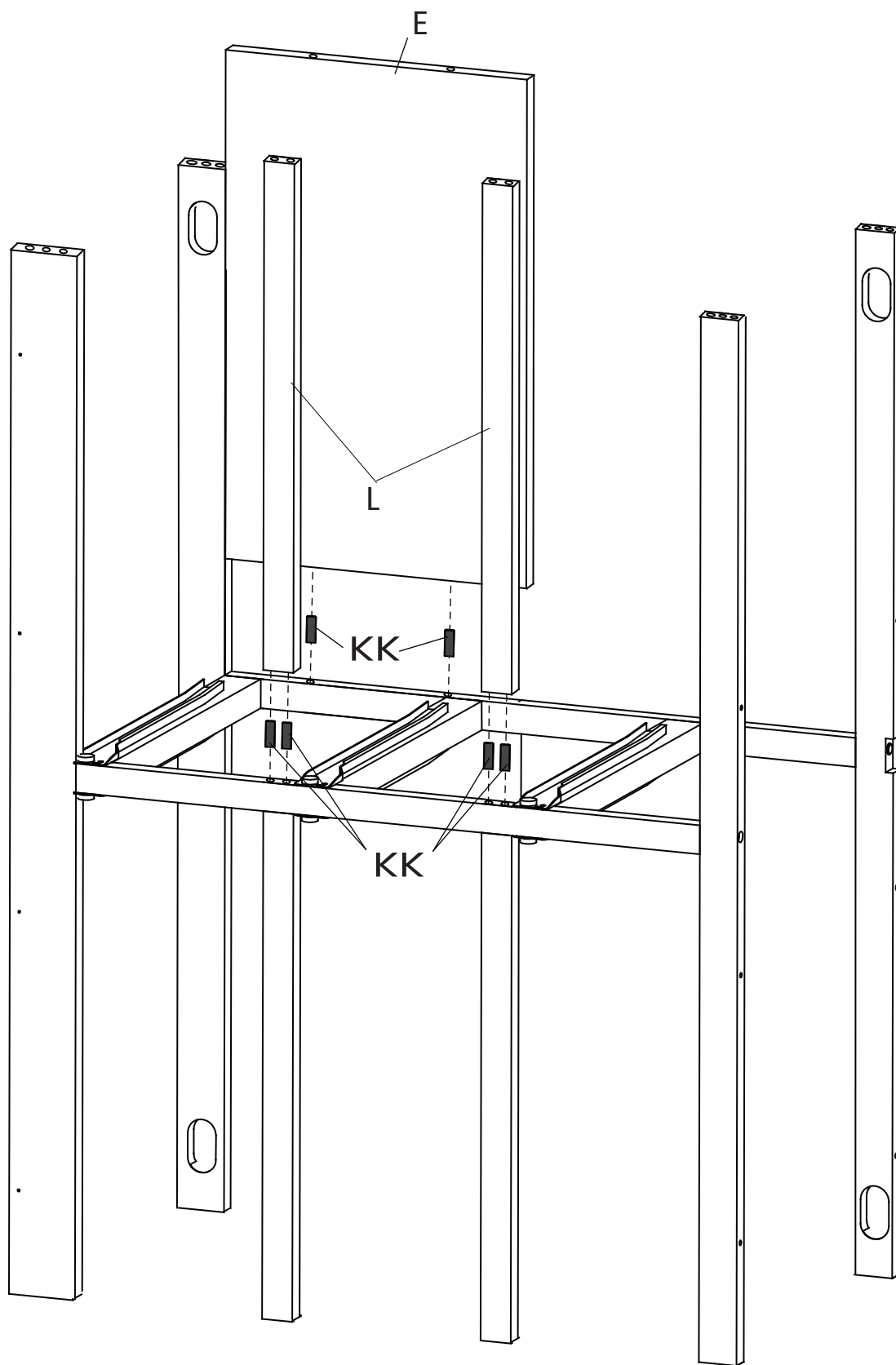

STEP 3 PASO 3

Parts and tools required to complete step
Piezas y herramientas necesarias para completar este paso



BB M6x60mm Bolt x4
Perno M6x60mm

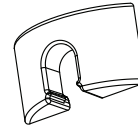

MM Crescent Washer x4
Arandela de Media Luna



KK Φ 8x30mm Wood Dowel x14
Pasador de madera Φ 8x30mm

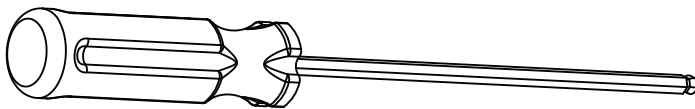

M4 Ballend Screwdriver
destornillador M4 con cabeza de bola

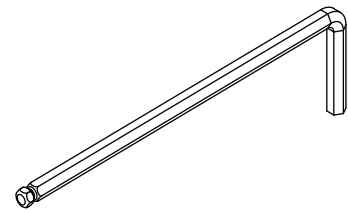

M4 Allen Wrench
Llave Allen M4

Attach the Left Side (Part A) to the assembly from Step 2 using (14) 30mm Wood Dowels (Part KK), (4) 60mm Bolt (Part BB) and (4) Crescent Washer (Part MM). Tighten the Bolts with the M4 BallendScrewdriver and M4 Allen wrench, following their instructions on pages 14 and 15.

Fije el lado izquierdo (Pieza A) al ensamblaje del Paso 2 utilizando (14) Pasadores de madera 30mm (Pieza KK), (4) pernos de 60 mm (Pieza BB) y (4) arandelas crescent (Pieza MM) utilizando el destornillador M4 con cabeza de bola y la llave Allen M4 siguiendo las instrucciones de las páginas 14 y 15.

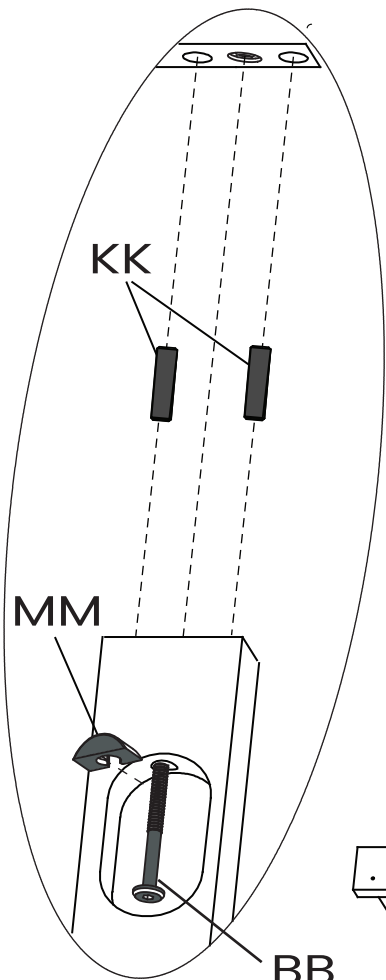

x4

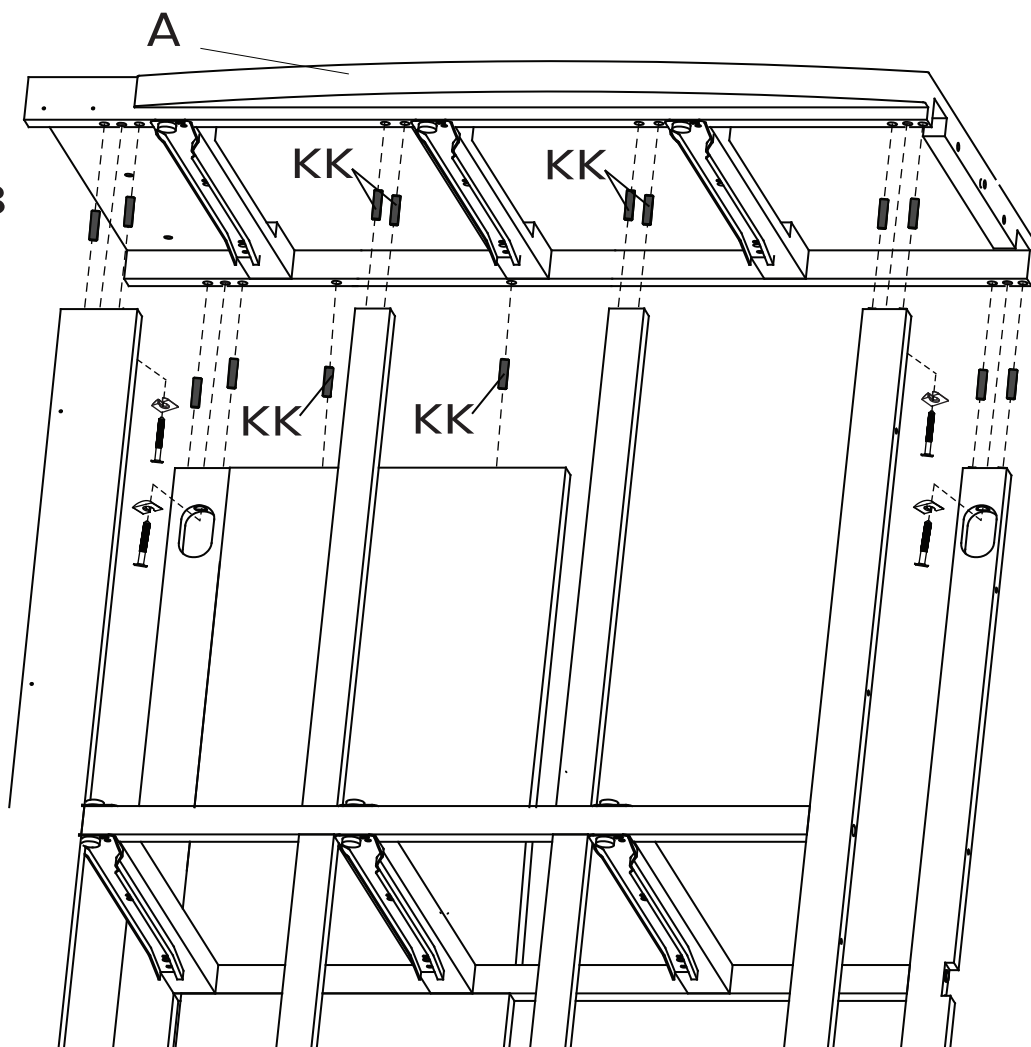

STEP 4
PASO 4

Parts and tools required to complete step

Piezas y herramientas necesarias para completar este paso



Φ8x30mm Wood Dowel x6

Pasador de madera Φ8x30mm

Attach (1) Back Weight (Part E), (2) Drawer Rails (Part L) to the assembly from Step 3 using (6) 30mm Wood Dowels (Part KK).

Fije (1) peso trasero (Pieza E) y (2) rieles de gaveta (Pieza L) en el ensamblaje del Paso 3 utilizando (6) Pasadores de madera 30mm (Pieza KK).

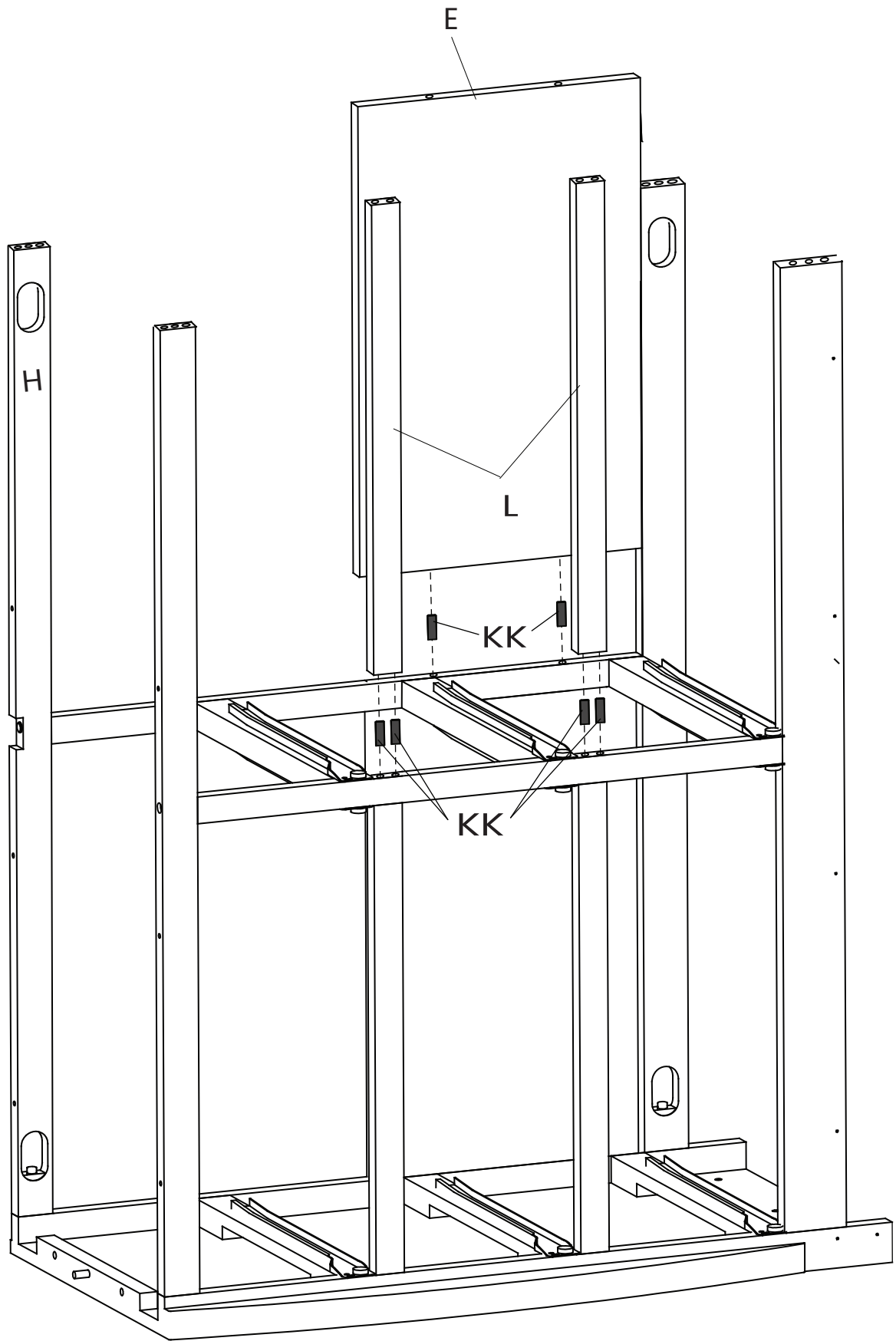

STEP 5 PASO 5

Parts and tools required to complete step
Piezas y herramientas necesarias para completar este paso



BB M6x60mm Bolt x4
Perno M6x60mm

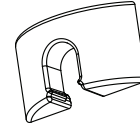

MM Crescent Washer x4
Arandela de Media Luna

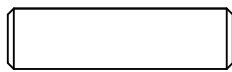

KK Φ 8x30mm Wood Dowel x14
Pasador de madera Φ 8x30mm

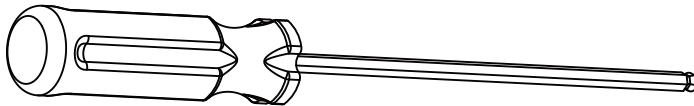

M4 Ballend Screwdriver
destornillador M4 con cabeza de bola

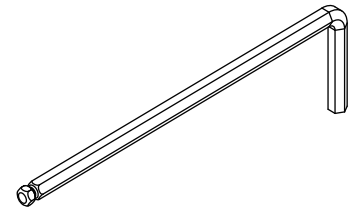

M4 Allen Wrench
Llave Allen M4

Attach the Right Side (Part B) to the assembly from Step 4 using (14) 30mm Wood Dowels (Part KK), (4) 60mm Bolt (Part BB) and (4) Crescent Washer (Part MM). Tighten the Bolts with the M4 BallendScrewdriver and M4 Allen wrench, following their instructions on pages 14 and 15.

Fije el lado derecho (Pieza B) al ensamblaje del Paso 4 utilizando (14) Pasadores de madera 30mm (Pieza KK), (4) pernos de 60 mm (Pieza BB) y (4) arandelas crescent (Pieza MM) utilizando el destornilladorM4 con cabeza de bola y la llave Allen M4 siguiendo las instrucciones de las páginas 14 y 15.

x4

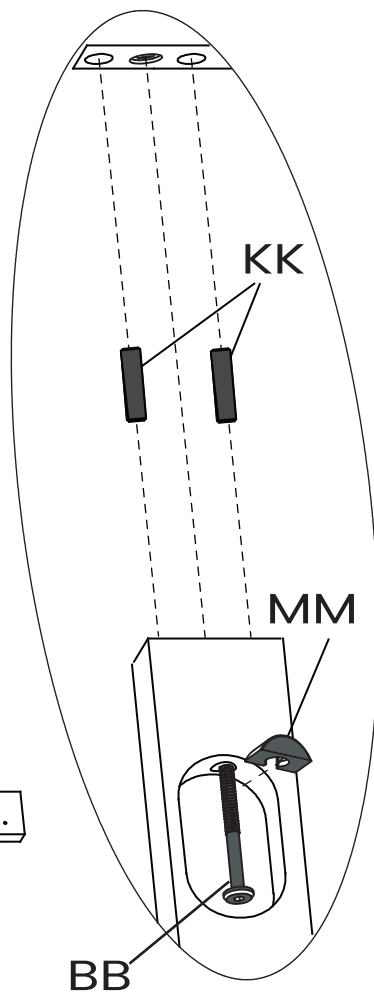
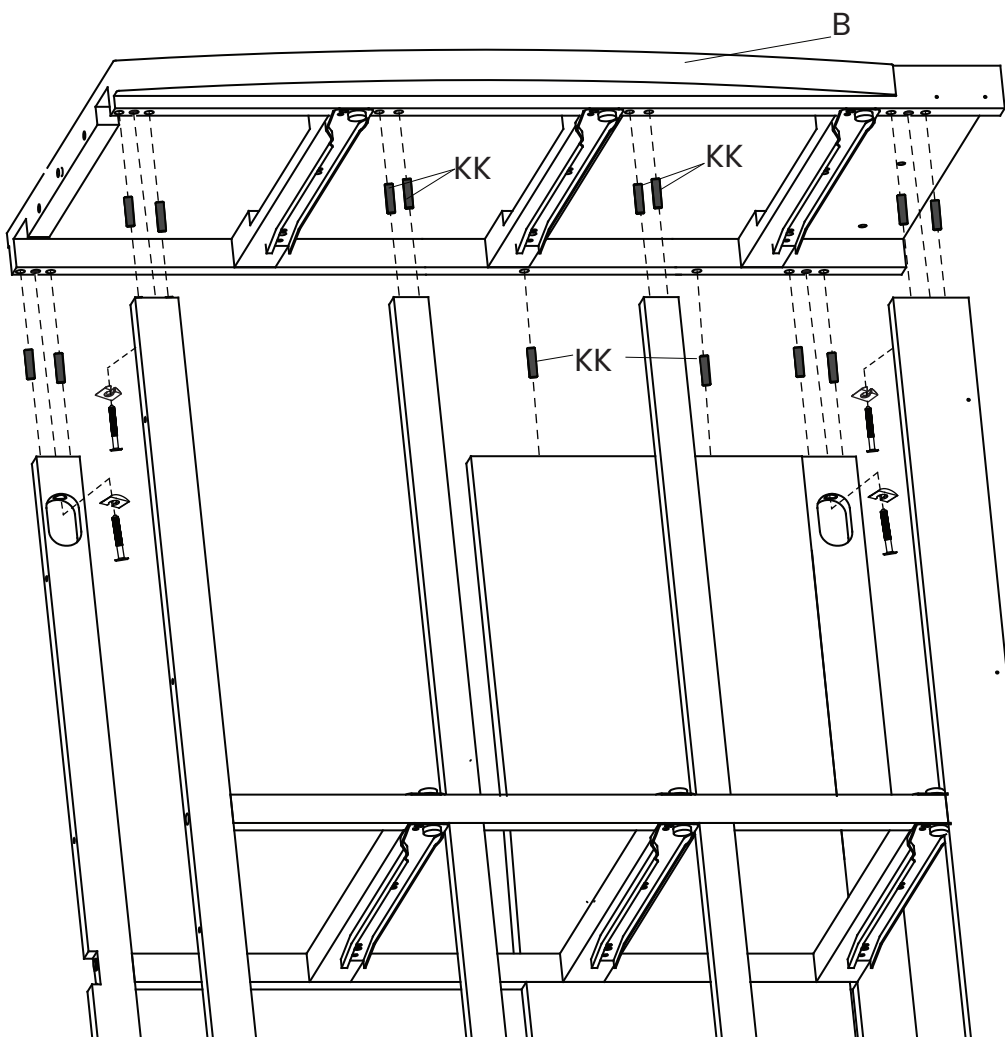

STEP 6 PASO 6

Parts and tools required to complete step
Piezas y herramientas necesarias para completar este paso

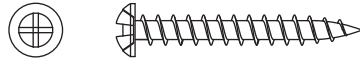

GG 30mm Screw x14
Tornillo 30mm

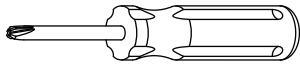

Phillips Screwdriver – Not included
Destornillidor Phillips – no incluido

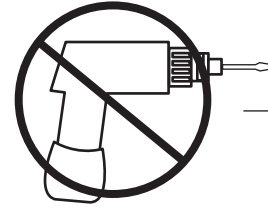

No drills necessary.
Do not use power screwdriver.

No hace falta taladrar.
No utilice destornilladores eléctricos

1. Attach the Bottom Front Molding (Part K) to the front of the case using (8) 30mm Screws (Part GG), ensure the screws go into the predrilled holes in the molding. Tighten with a Phillips screwdriver.

2. Attach the (2) Bottom Side Moldings (Part N) to the case using (3) 30mm screws (Part GG) for each, ensure the screws go into the predrilled holes in the molding.

1- Fijar la moldura frontal (pieza K) utilizando (8) tornillos de 30mm (pieza GG). Apretar con el destornillador de estrella.

2. Fijar las molduras laterales (pieza N) a cada lado utilizando (3) tornillos de 30mm (pieza GG). Alinear el frente de la moldura lateral con la moldura frontal. Apretar con el destornillador de estrella.

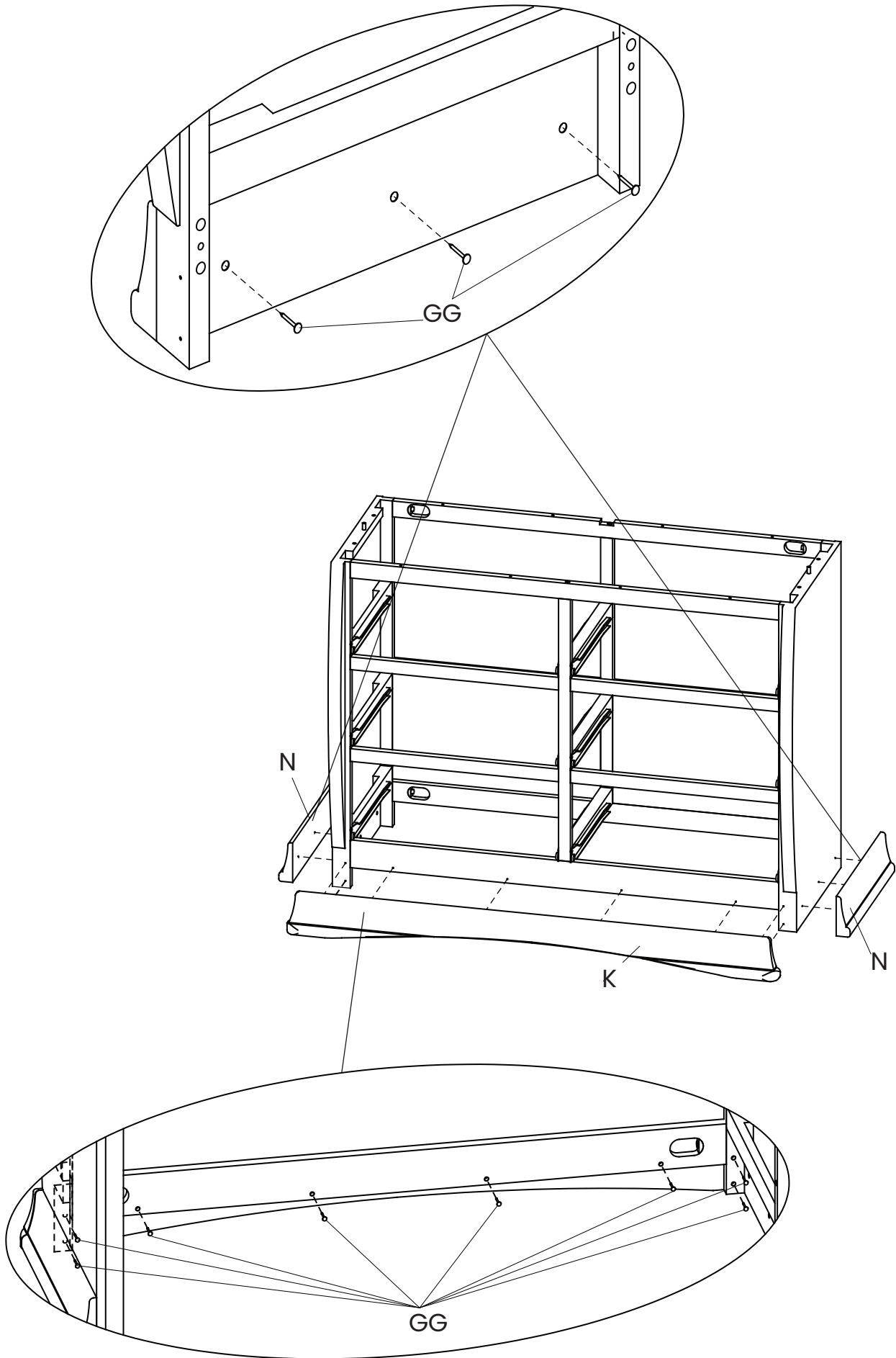

STEP 7 PASO 7

Parts and tools required to complete step
Piezas y herramientas necesarias para completar este paso



DD M6x45mm Bolt x8
Perno M6x45mm

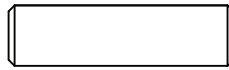

KK Φ 8x30mm Wood Dowel x2
Pasador de madera Φ 8x30mm

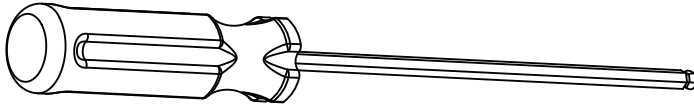

M4 Ballend Screwdriver
destornillador M4 con cabeza de bola

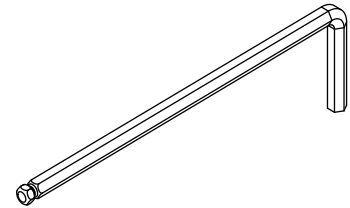

M4 Allen Wrench
Llave Allen M4

Attach the Top Panel (Part D) to the assembly from Step 6 using (2) 30mm Wood Dowels (Part KK) and (8) 45mm Bolts (Part DD) . Tighten the Bolts with the M4 Ballend Screwdriver and M4 Allen wrench.

Fije el Panel superior (Pieza D) al ensamblaje del Paso 6 utilizando (2) Pasadores de madera 30mm (Pieza KK) y (8) pernos de 45 mm (Pieza DD) utilizando el destornillador M4 con cabeza de bola y la llave Allen M4.

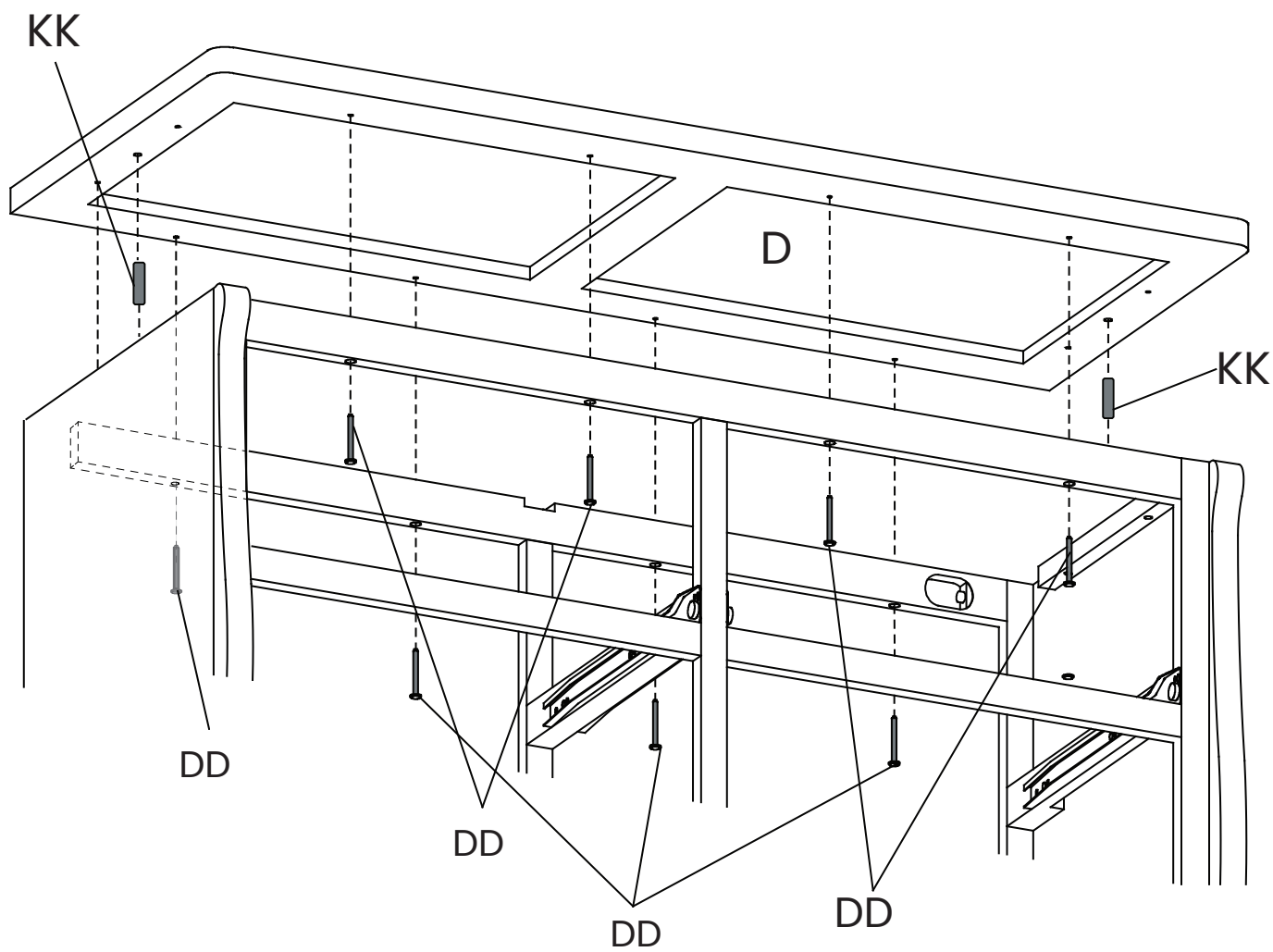

STEP 8
PASO 8

Parts and tools required to complete step

Piezas y herramientas necesarias para completar este paso

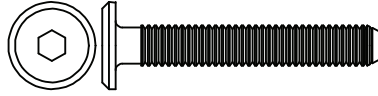
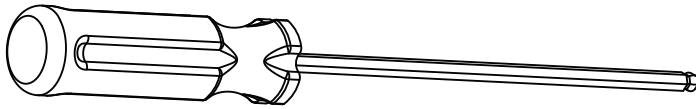
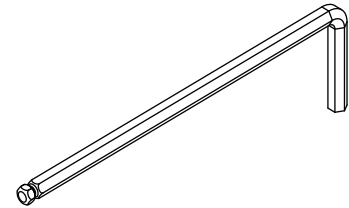
**EE** M6x35mm Bolt x4
Perno M6x35mmM4 Ballend Screwdriver
destornillador M4 con cabeza de bolaM4 Allen Wrench
Llave Allen M4

Attach the Top Panel (Part D) 6 using (4) 35mm Bolts (Part EE) . Tighten the Bolts with the M4 Ballend Screwdriver and M4 Allen wrench.

Fije el Panel superior (Pieza D) utilizando (4) pernos de 35 mm (Pieza EE) utilizando el destornillador M4 con cabeza de bola y la llave Allen M4.

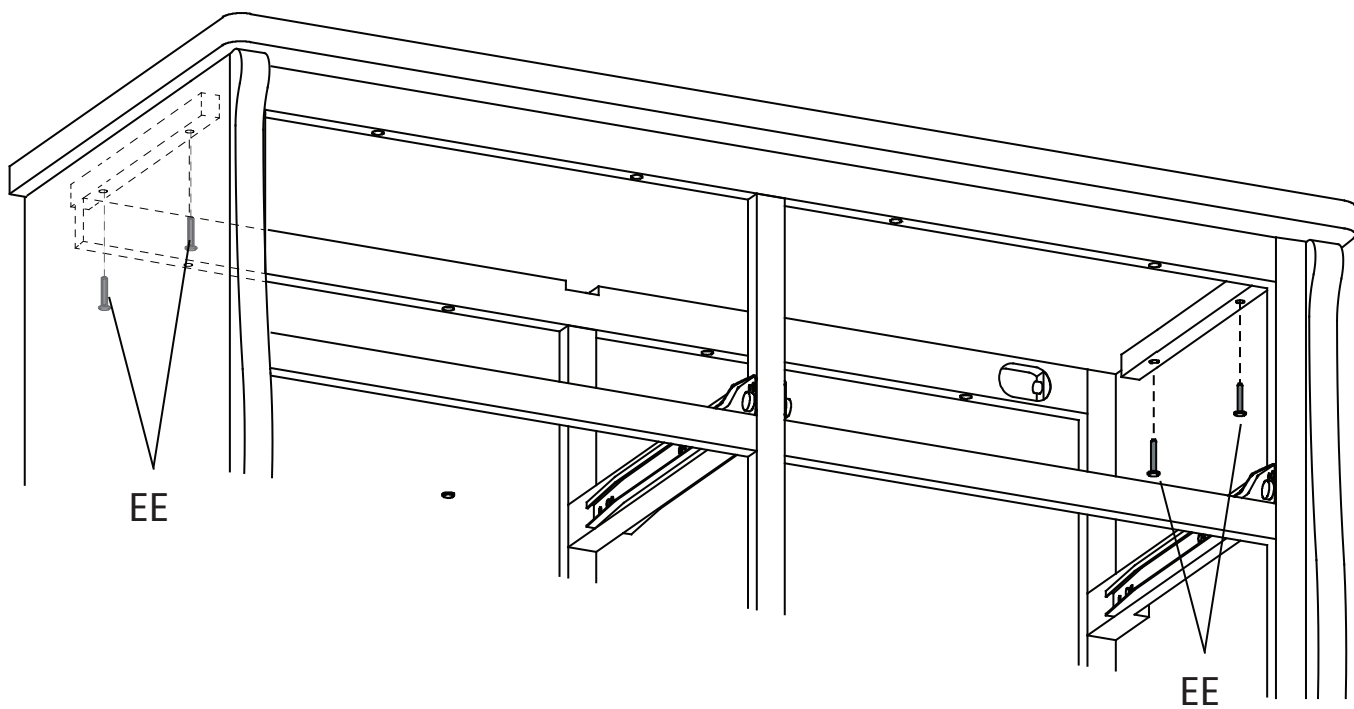

STEP 9 PASO 9

Parts and tools required to complete step
Piezas y herramientas necesarias para completar este paso

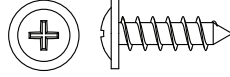

HH 16mm Back Panel Screw x20
Tornillo 16mm de Panel Trasero

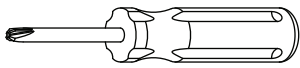

Phillips Screwdriver – Not included
Destornillador Phillips – no incluido

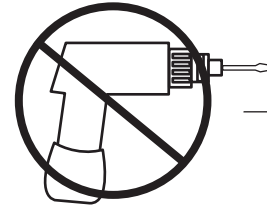

No drills necessary.
Do not use power screwdriver.

No hace falta taladrar.
No utilice destornilladores eléctricos

Attach (2) Back Panels (Part M)
using (20) Screws (Part HH). Tighten
with a Phillips Screwdriver.

Fije los (2) Paneles traseros (Parte M) con
ayuda de (20) Tornillos (Parte HH). Apriete
con un destornillador de cruz.

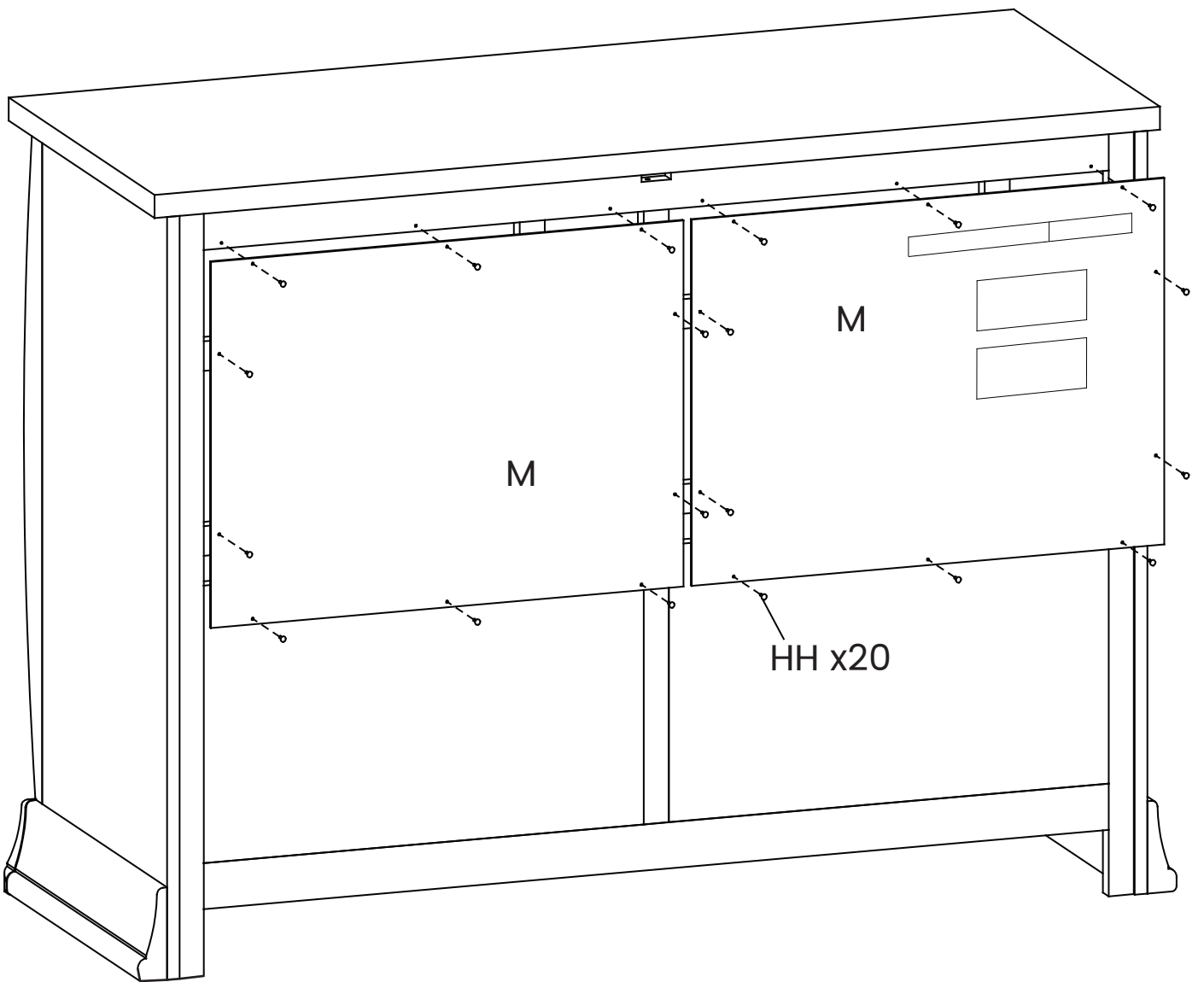

STEP 10
PASO 10

Tipover Restraint
Protección contra volcamiento

▲ WARNING
Use of tip-over restraints may only reduce, but not eliminate, the risk of tip-over.
Do not attempt to Screw into the wallboard only. You must Screw into a wood wall stud or other wood structure such as securely attached baseboard. If your wall is not wood stud construction, see your local hardware store or home center for a wall anchor system that will hold a pull force of 50 LBS in your wall type. If you are unsure of how to locate the wood stud, or of what type of wall you have, contact a professional contractor.

▲ ADVERTENCIA
El uso de herramientas de contención de vuelcos tan solo puede reducir, pero no eliminar, el riesgo de vuelco.
No intente atornillar a paredes hechas únicamente de paneles. Debe atornillar en un pilar u otra estructura de madera similar, como un zócalo fijado de manera segura. Si su pared no tiene vigas de Madera, visite su ferretería o tienda del ramo más cercana para conseguir un sistema de anclaje que soporte una fuerza de tiraje de hasta 50 LBS (22,7 Kgs) para su tipo de muro. Si no está seguro sobre cómo encontrar la viga de madera o tiene dudas sobre el tipo de muro, contacte a un contratista profesional.

- 1) Choose BOTTOM or TOP attachment.
- 2) Locate the through holes in the back of the dresser.
- 3) Align the hole to be used with the wood wall stud (For Open Bottom Installation, use wood wall stud closest to center)

- 1) Seleccione el aditamento SUPERIOR o INFERIOR.
- 2) Ubique los orificios pasantes en la parte posterior del mueble.
- 3) Alinee el orificio que utilizará con el pilar de la pared (para una instalación con fondo abierto, utilice el pilar de madera más cercano al centro)

4) Make a pencil mark on the wall using the wood rail as a guide, pencil mark must be over wood wall stud. Then move the case away from the wall.

4) Utilizando un lápiz, haga una marca en la pared utilizando el barra de madera como guía; la marca debe estar sobre el pilar de madera. Luego, aleje la carcasa de la pared.

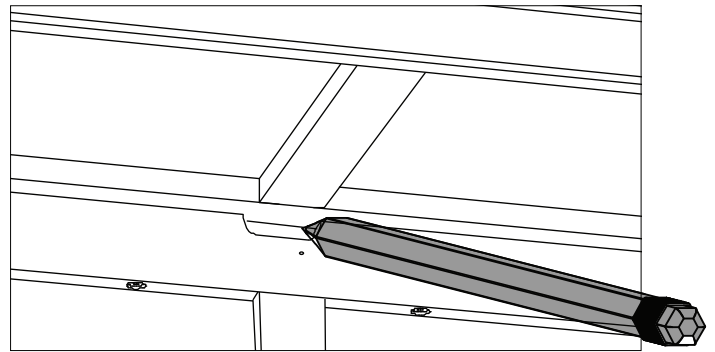

5) Drill $\varnothing 1/8"$ hole at Pencil Mark, in wood wall stud

5) Perfore un orificio de $\varnothing 1/8"$ en la marca del lápiz, sobre el pilar de madera

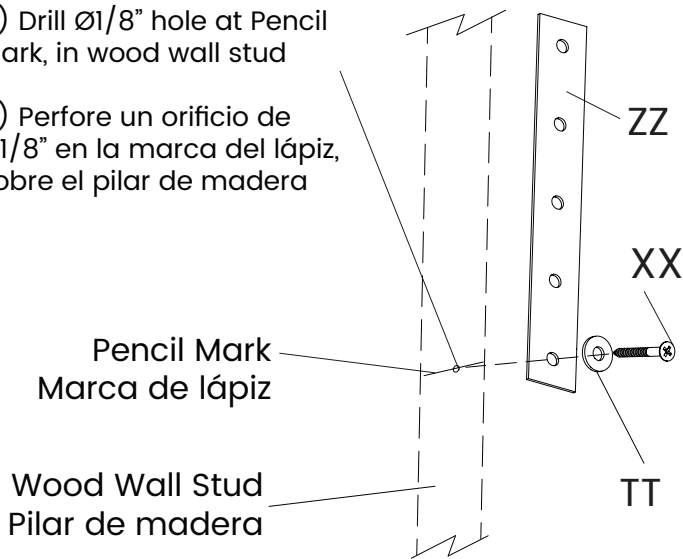

6) Attach the Tip-over restraint strap (ZZ) to the wall using (1) Long Screw (XX) and (1) washer (TT) as shown. The Screw MUST be installed into a wood wall stud (See WARNINGS for additional information).

6) Fije la correa de retención contra volcamiento (ZZ) a la pared utilizando (1) tornillo largo (XX) y (1) arandela (TT), como se indica. El tornillo DEBE instalarse en un pilar de madera (para obtener más información consulte las ADVERTENCIAS).

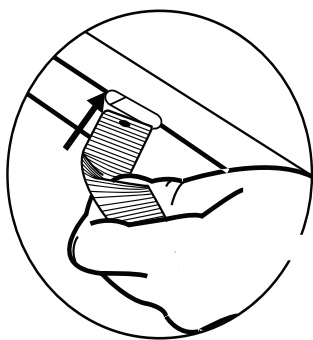

NOTE: Be sure to attach any accessory items to case before completing this step.

7) Feed the Tipover Restraint through the hole as you place the dresser in it's final position.

NOTA: Asegúrese de fijar todos los accesorios a la carcasa antes de completar este paso.

7) Pase el elemento de retención a través del orificio, a medida que posiciona el mueble en su posición final.

8) Pull the Tip-over restraint through the hole and fasten it securely to the case using (1) 15mm Screw (YY) and (1) washer (TT).

8) Pase el elemento de retención a través del orificio y fijelo con seguridad a la carcasa utilizando (1) tornillo de 15 mm (YY) y (1) arandela (TT).

Attach to Top
Fijar a la parte superior

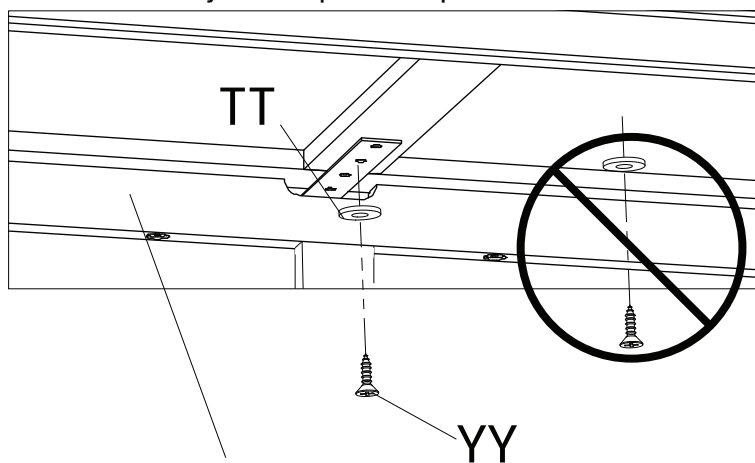

Top Back Rail
Barra Trasero Superior

Attach to Bottom
Fijar al fondo

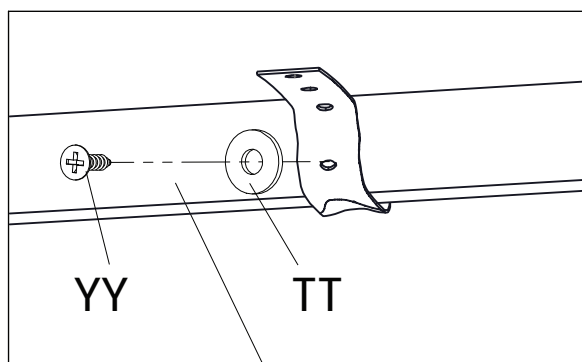

Bottom Back Rail
Barra Trasero Inferior

9) Pull case AWAY from wall until Restraint is SNUG.
9) Jale la carcasa ALEJÁNDOLA de la pared hasta que la retención esté TENSA.

10) Ensure restraint is not loose.
10) Asegúrese de que la retención no esté suelta.

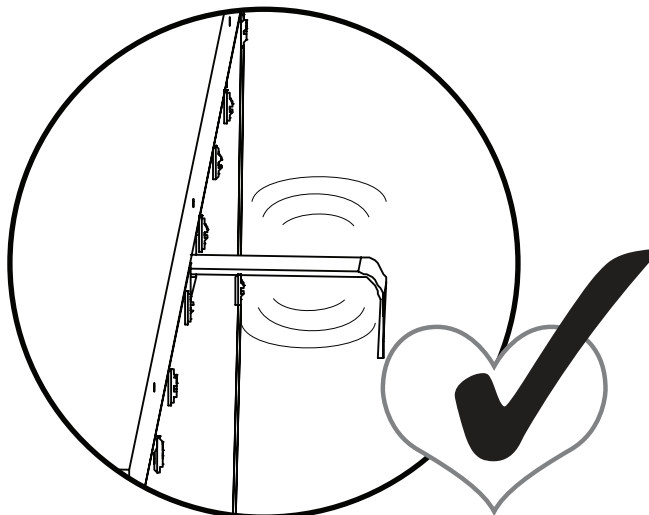
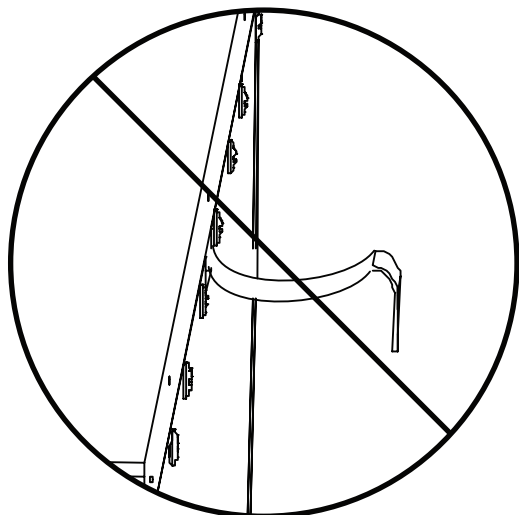

STEP 11 PASO 11

Parts and tools required to complete step
Piezas y herramientas necesarias para completar este paso

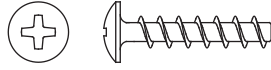

NN 20mm Screw x24
Tornillo 20mm

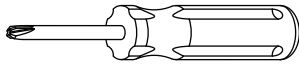

Phillips Screwdriver – Not included
Destornillidor Phillips – no incluido

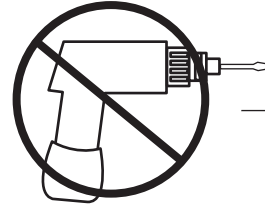

No drills necessary.
Do not use power screwdriver.

No hace falta taladrar.
No utilice destornilladores eléctricos

Slide Drawer Bottom (Part U) into the grooves. Attach the Right and Left Drawer Sides (Part T and S) to the Drawer Front (Part P) with (4) 20mm Screws (Part NN). Note: Grooves in Bottom must align. Tighten With Phillips Screwdriver. Repeat this step until 6 drawers are complete.

Deslice la Fondo de la gaveta (Pieza U) hacia las ranuras. Fije los Lados Izquierdo y Derecho de la Gaveta (Pieza T y S) a la parte frontal de la gaveta (Pieza P) utilizando (4) tornillos 20mm (Pieza NN). Nota: Las ranuras al inferior deben alinearse. Apriete utilizando un destornillador Phillips. Repita este paso hasta haber completado las 6 gavetas .

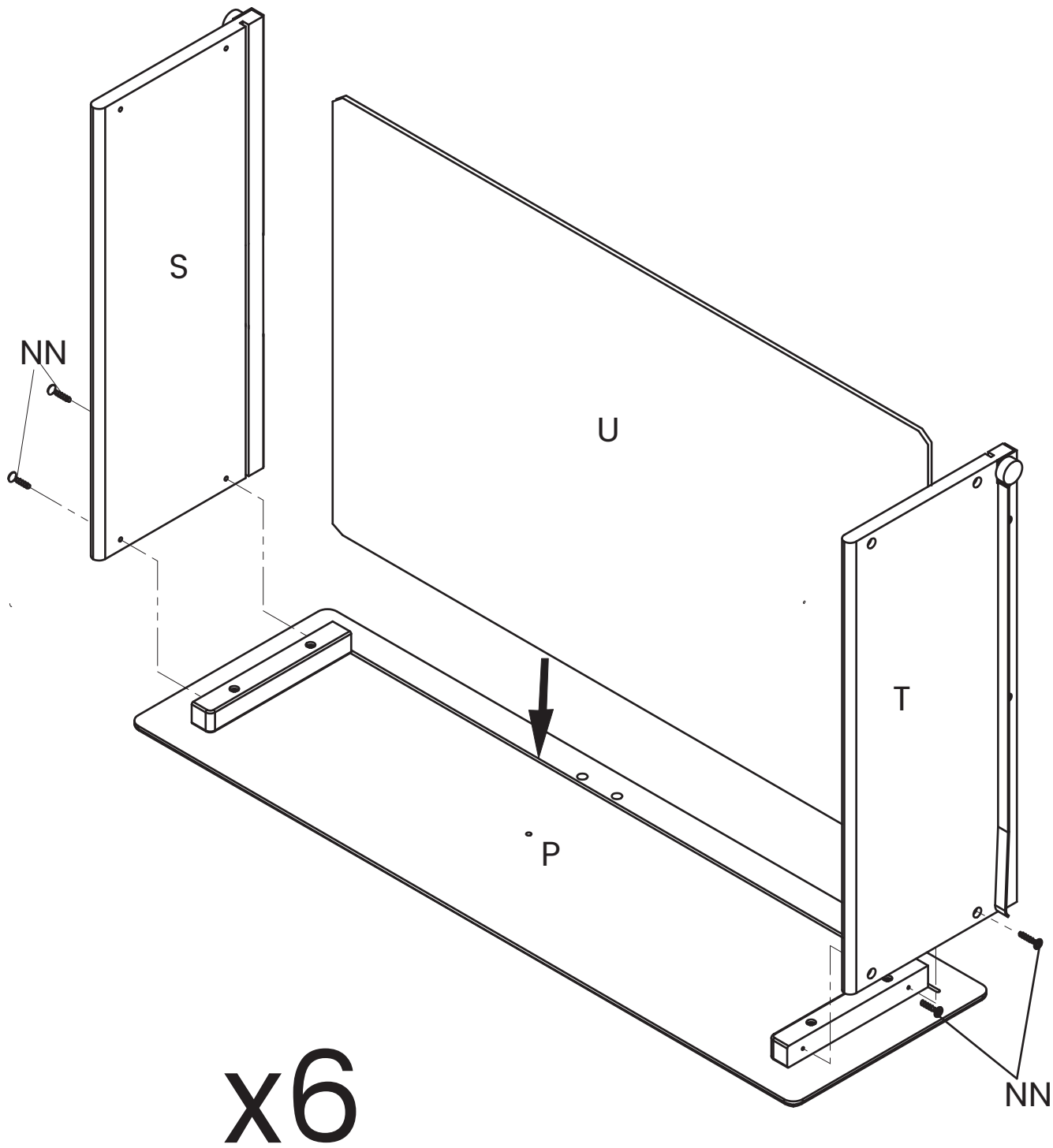

x6

STEP 12
PASO 12

Parts and tools required to complete step
Piezas y herramientas necesarias para completar este paso

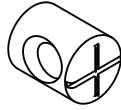

LL Plastic Barrel Nut x30
Tuerca cilíndrica plástica

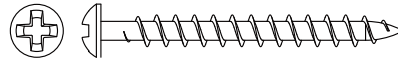

FF 40mm Screw x30
Tornillo 40mm

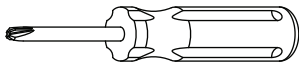

Phillips Screwdriver – Not included
Destornillidor Phillips – no incluido

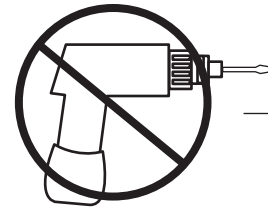

No drills necessary.
Do not use power screwdriver.

No hace falta taladrar.
No utilice destornilladores eléctricos

Slide Drawer Support (Part V) into the grooves. Attach Drawer Back (Part R) using (5) 40mm Screws (Part FF) and (5) Plastic Barrel Nuts (Part LL), ensure the grooves at the bottom line up. Repeat this step until all 6 drawers are complete.

Deslizar el Soporte de la gaveta (pieza V) en las ranuras. Fijar la parte posterior de la gaveta (pieza R) utilizando (5) tornillos de 40mm (pieza FF) y (5) tuercas plásticas de barril (pieza LL). Asegurarse de que las ranuras en el fondo estén alineadas.

Repita este paso hasta haber completado las 6 gavetas .

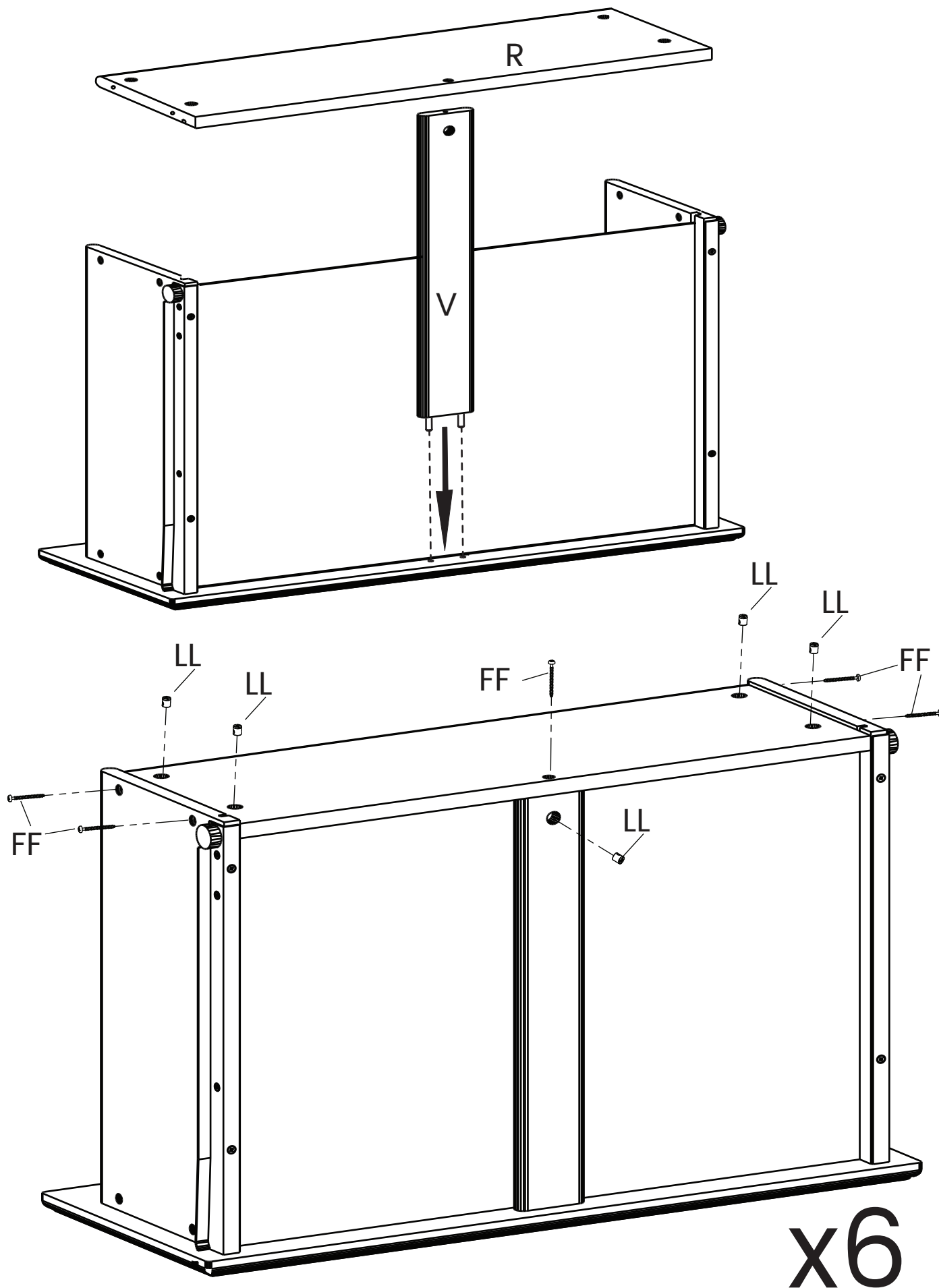

STEP 13 PASO 13

Parts and tools required to complete step

Piezas y herramientas necesarias para completar este paso



PP2. Knob Screw x6
Vis de Bouton
Tornillo para Perilla

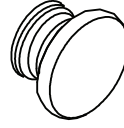

PP1. Knob x6
Bouton
Perilla

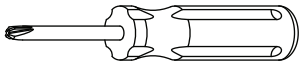

Phillips Screwdriver – Not included
Destornillidor Phillips – no incluido

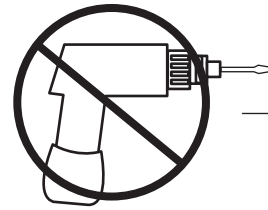

No drills necessary.
Do not use power screwdriver.

No hace falta taladrar.
No utilice destornilladores eléctricos

Attach (1) Drawer Knob (Part PP1) to each drawer with (1) Knob Screw (Part PP2).
Tighten with a Phillips Screwdriver.
Tighten With Phillips Screwdriver.
Repeat this step until 6 drawers are complete.

Fije (1) pomo de gaveta (Pieza PP1) a cada gaveta utilizando (1) tornillo para pomos (Pieza PP2). Apriete utilizando un destornillador Phillips.
Repita este paso hasta haber completado las 6 gavetas .

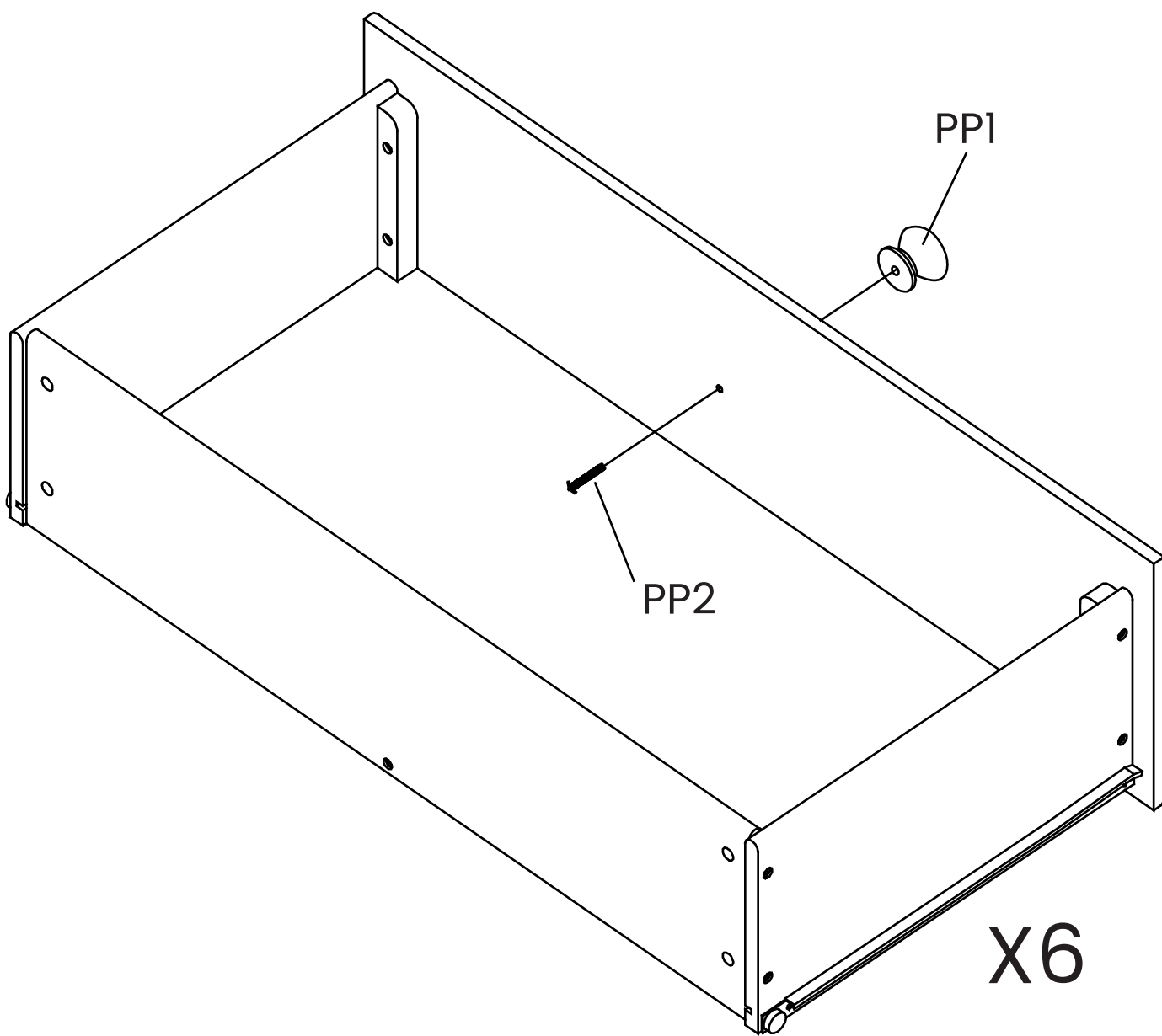

STEP 14
PASO 14

Install the drawers in the case body. Carefully align the Drawer Guides on each drawer with the Drawer Guides on the case. Check that each side is fully secure. Open and close the drawer to ensure smooth operation. Changing the locations may improve fit or performance.

Instale las gavetas en el cuerpo del mueble. Alinee cuidadosamente las guías de gaveta en cada una de ellas con las guías del cuerpo del mueble. Revise que cada lado esté bien asegurado. Abra y cierre la gaveta para asegurarse de que funciona correctamente. Cambiar las ubicaciones podría mejorar el funcionamiento.

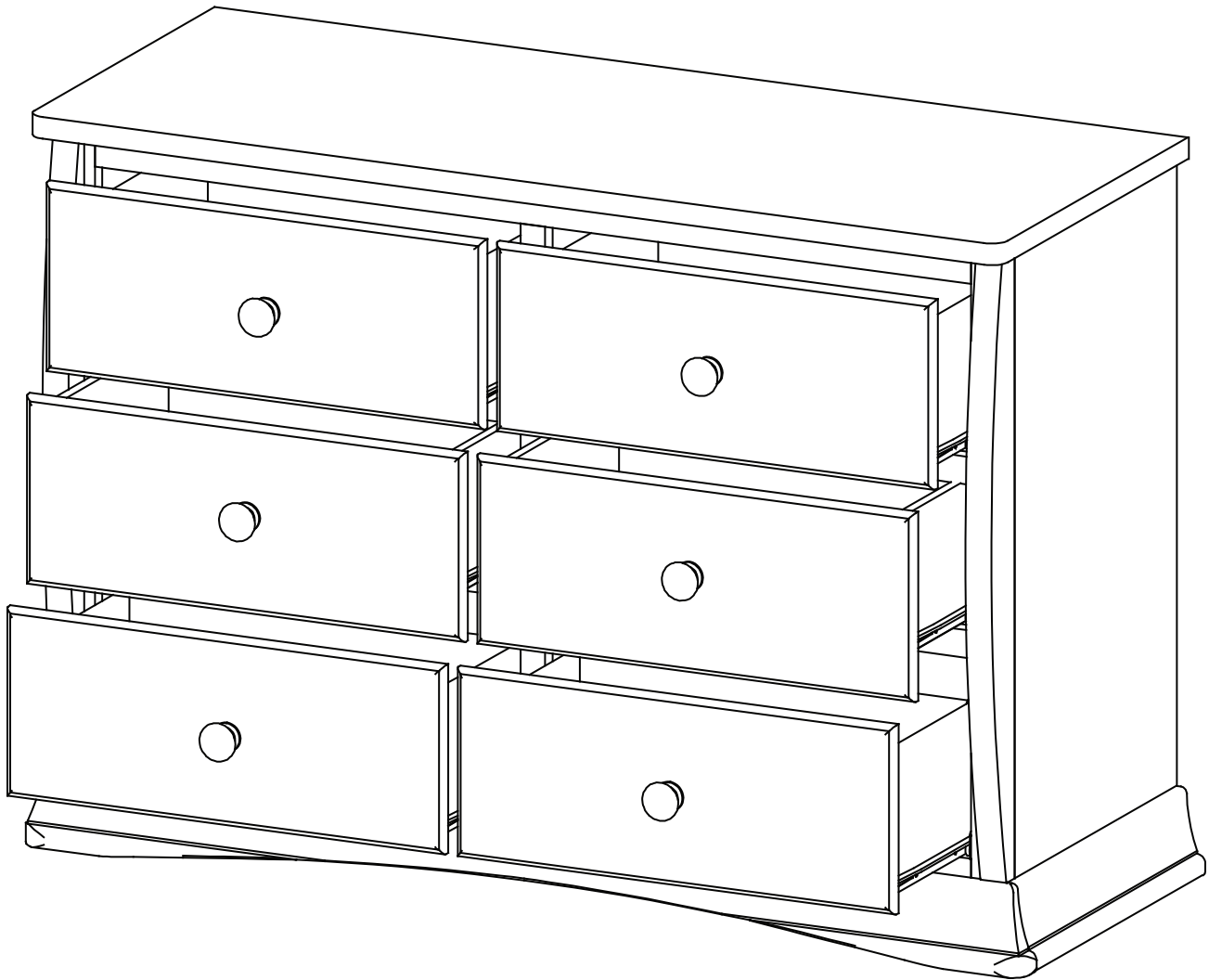

Limited Warranty:

This Delta Product is warranted to be free from defects for a period of 90 days from the date of purchase under normal use. If a product is defective during this period, we will at our option repair or replace the defective part or product. This limited warranty extends only to the original retail purchaser and is valid only when supplied with proof of purchase, or if received as a gift, when the registration is on file with Delta. This limited warranty does not cover the following:

- Products purchased as floor models or samples.
- Items purchased on an “as-is” basis, as a second hand product, or as a resale product.
- Items purchased at a Final sale, a “Going out of Business” sale or a Liquidation sale.

This limited warranty gives you specific legal rights and you may also have other rights which vary from state to state.

To register your product

for important safety alerts and updates to your product please visit
www.deltachildren.com

To report a problem

please log on to www.deltachildren.com/help

Date of Purchase: _____ (you should also keep your receipt)

Garantía Limitada:

Este Producto Delta está garantizado de estar libre de defectos por un período de 90 días a partir de su adquisición, bajo uso normal. Si un producto tiene defectos durante este período, Nosotros tomaremos la opción de reparar o reemplazar la pieza defectuosa del producto. Esta garantía limitada se otorga únicamente al comprador original y es válida solamente cuando se proporciona una prueba de compra, o si el producto fue recibido como un regalo, debe haber sido registrado con Delta. Esta garantía limitada del fabricante no cubre lo siguiente:

- Productos comprados como exhibiciones de la tienda o muestras.
- Artículos comprados como “tal como está”, productos de segunda mano o reventa de los productos.
- Artículos comprados como “venta final”, “ventas de tiendas que están quebrando” o ventas por liquidación.

Esta garantía limitada le otorga derechos legales específicos y también puede tener otros derechos que varían de un estado a otro.

Para registrar su producto

para alertas importantes de seguridad y estar al tanto sobre novedades de su producto por favor visite
www.DeltaChildren.com

Para reportar cualquier problema

por favor entre a www.DeltaChildren.com/help

Fecha de Compra: _____ (debe además mantener su recibo)

SAFETY LEADERS

Visit Deltachildren.Com/Pages/Leaders-In-Safety for more information

SAFE MATERIALS

Safe products start with safe materials. We test all of our products to create the safest and healthiest environment for your baby.



PRODUCTS YOU CAN TRUST

We have 8 cutting edge safety labs around the world where we test our products above and beyond the industry standards. All of our dressers are engineered to meet or exceed ASTM Furniture Safety Standards.



WE GO ABOVE & BEYOND

To protect your children, Delta Children dressers are tested to meet the requirements of the industry tip over test set forth by ASTM. For additional security, we strongly recommend that all dressers in you home be anchored; all Delta Children dressers include a wall anchor.



LÍDERES EN LA SEGURIDAD

Visite Deltachildren.Com/Pages/Leaders-In-Safety para más información

MATERIALES SEGUROS

Los productos seguros se hacen con materiales seguros. Ponemos a prueba todos nuestros productos para crear el ambiente más seguro y saludable para su bebé.



PRODUCTOS CONFIABLES

Tenemos 8 laboratorios de seguridad de alta tecnología donde probamos nuestros productos más allá de los estándares de la industria. Todos nuestros tocadores están diseñados para cumplir o exceder los estándares de seguridad ASTM de muebles.



ESTAMOS POR ENCIMA Y MÁS ALLÁ

Para proteger a sus niños, los tocadores de Delta Children son sometidos a pruebas para que cumplan los requisitos ASTM establecidos de la industria en cuanto a volcamientos se refiere.

Para seguridad adicional, recomendamos enfáticamente que todos los tocadores de su casa estén fijos: todos los tocadores de Delta Children incluyen un anclaje de pared.



POR QUÉ ELEGIR A DELTA CHILDREN?

Visita Deltachildren.Com/Pages/Our-Story para más información

DELTA LIDERA

1 de cada 2 niños en los EE.UU duerme en nuestros productos

DELTA DONA

10% de nuestros ingresos está destinado a mejorar la vida de los niños

A DELTA LE IMPORTA

Hacemos pruebas por encima de los estándares de seguridad de la industria

DELTA ESTÁ DEDICADA

Nuestra empresa familiar ha estado siempre presente para su familia desde 1968

DELTA CRECE CON USTEDES

Tenemos productos para cada edad y etapa

Más De 50 Años De Seguridad, Estilo E Innovación

Bienvenido a la
FAMILIA DELTA

Aquí Está Nuestro Regalo Para Usted

10% OFF

Su Próxima Compra En
DeltaChildren.com

UTILICE EL CÓDIGO:
DELTA10

PRODUCTOS PARA CADA EDAD Y ETAPA



CUNAS



COSAS PARA BEBÉ



SILLA



MOISÉS



COLCHÓN



CARRIOLAS

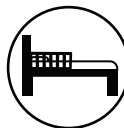

CAMA PARA NIÑO



CUARTO DE JUGAR



CAMA SENCILLA



CONTENEDORES



TOCADORES

NUESTRA FAMILIA DE LAS MEJORES MARCAS



MÁS DE 50 AÑOS DE SEGURIDAD, ESTILO E INNOVACIÓN

WHY CHOOSE DELTA CHILDREN?

Visit Deltachildren.Com/Pages/Our-Story for more information

<p>DELTA LEADS 1 Out Of 2 Children In The U.S. Sleep In Our Products</p>	<p>DELTA GIVES 10% Of Our Profits Go Toward Improving The Lives Of Children</p>	<p>DELTA CARES We Test Above & Beyond Industry Safety Standards</p>	<p>DELTA IS DEDICATED Our Family-Run Company Has Been There For Your Family Since 1968</p>	<p>DELTA GROWS WITH YOU We Have Products For Every Age And Stage</p>	<p>Over 50 Years Of Safety, Style & Innovation</p>
---	--	--	---	---	---

Welcome to the **DELTA FAMILY**
Here's a Gift From Us To You









10% OFF

Your Next Purchase From DeltaChildren.com

USE CODE:
DELTA10

*Exclusions Apply
*Subject to Change

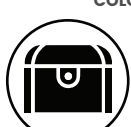
PRODUCTS FOR EVERY AGE AND STAGE

 CRIBS LITS POUR BÉBÉ CUNAS	 STROLLERS ÉQUIPEMENT POUR BÉBÉ COSAS PARA BEBÉ	 GLIDERS CHAISE SILLA	 BASSINETS COUFFINS MOISÉS	 MATRESSES MATELAS COLCHÓN	
 BABY GEAR POUSSETTES CARRIOLAS	 TODDLER BEDS LITS POUR ENFANT CAMA PARA NIÑO	 PLAYROOM FURNITURE SALLE DE JEUX CUARTO DE JUGAR	 TWIN BEDS LITS UNE PLACE CAMA SENCILLA	 BINS & ORGANIZERS PANIERES CONTENEDORES	 DRESSERS COMMODES TOCADORES

OUR FAMILY OF TOP BRANDS



OVER 50 YEARS OF SAFETY, STYLE, AND INNOVATION