

# ROOM2GROW

Newborn Bassinet to Infant Sleeper

SIMMONS KIDS®

## INSTRUCTION MANUAL

### 25502

Styles and colors may vary



### **⚠ WARNING:** **CHOKING HAZARD**

Adult assembly required because of small parts. Keep assembly parts out of reach of children under 3 years.

Read all instructions BEFORE assembly and USE of product  
KEEP INSTRUCTIONS FOR FUTURE USE.

Customer Experience Center  
phone: (646) 435-8726  
email: [gcs@DeltaChildren.com](mailto:gcs@DeltaChildren.com)



DELTA CHILDREN

[www.DeltaChildren.com](http://www.DeltaChildren.com)



DCP-IM-03202020-F10

## Consumer Information



### WARNING

**WARNING:** Do not use this bassinet if you cannot exactly follow the accompanying instructions. Failure to follow these warnings and instructions could result in serious injury or death.

• **Read all instructions before assembling unit.**

**KEEP INSTRUCTIONS FOR FUTURE USE.**

**DO NOT USE THIS UNIT IF THE INSTRUCTIONS CANNOT BE STRICTLY FOLLOWED.**

- Before each usage or assembly, inspect unit for damaged hardware, loose joints, missing parts or sharp edges. NEVER use this product if there are any loose or missing fasteners, loose joints, broken parts, or torn mesh/fabric. Check before assembly and periodically during use. Contact Simmons Customer Service Department at (646) 435-8726 for replacement parts, repair or instructions.

## SUFFOCATION HAZARD

### Infants have suffocated:

- In gaps between an extra padding, a mattress (too small or too thick) and product sides.
- On soft bedding.
- Use only the pad provided by the manufacturer that is no thicker than 25 mm (1 in) and is of such a size that, when pushed against any side of the product, it does not leave a gap of more than 25 mm (1 in) between the mattress and sides.
- **NEVER** add a pillow, comforter or another mattress for padding.
- Remove any tools or excess parts including plastic packaging from bassinet vicinity after assembly.
- Always make sure both sides of the bassinet are adjusted at the same height position making the bassinet equally leveled.
- Do not use the body of the bassinet without its frame.

**FALL HAZARD:** To help prevent falls, discontinue use of this product in the bassinet mode when infant begins to push up on hands and knees or reaches 5 months of age. Whichever comes first. Product may be converted to sleeper mode to accommodate infants up to 12 months of age. See details in instructions.

- To reduce the risk of SIDS, pediatricians recommend healthy infants be placed on their backs to sleep, unless otherwise advised by your physician.
- Always attach all provided fasteners tightly according to the instructions. Check frequently. Do not use if there are any loose or missing parts or signs of damage. Do not substitute parts. Contact the manufacturer for replacement parts.
- Always pull out legs to full extension when in use.
- Use bassinet with only one child at a time.
- Strings can cause strangulation! DO NOT place items with a string around a child's neck, such as hood strings or pacifier cords. DO NOT suspend strings over a product or attach strings to toys.
- Toys are not to be "mouthed" by the baby and should be positioned clearly out of reach of the baby's face and mouth.
- Do not place medication, small toys, small items, cords, straps or similar items that could become wound around the child's neck in or near this product and do not place product near a window, patio door, heater, or power outlet.
- If a sheet is used with the pad, use only the one provided by the manufacturer or one specifically designed to fit the dimensions of the bassinet mattress.
- Always check that the bassinet is securely locked on the base/stand by pulling upwards on the bassinet bed.
- Never convert product to a sleeper with baby inside.



## **Before returning this product to the store! Let's see if we can assist you!**

- **Not sure how to assemble our product?**

Visit our site for easy to follow instructions along with some Tricks and Tips assembly videos <https://www.deltachildren.com/pages/instructions>

- **If you are missing a piece or have a damaged part**

Please contact our Consumer Experience Center for assistance at 646-435-8726 or email [gcs@DeltaChildren.com](mailto:gcs@DeltaChildren.com). To better assist you please have your Style# or Model# and Lot# available. This can be found on a white rectangular sticker on your product, on the registration card, and on the product's box.

- **In the event we do not have a replacement part available**

You may need to return your product to the retailer for an exchange or refund.

- **Warranty**

In order to protect your investment, don't forget to register your product. You may also wish to consider purchasing our extended warranty.

Visit <https://www.deltachildren.com/pages/extended-warranty> for more details.

- **Please note:**

"All Final", "As Is" or Third Party/Liquidator sales are not covered under our Limited Manufacturer Warranty.

# DELTA CHILDREN

## LIMITED MANUFACTURER WARRANTY

This Delta product is warranted to be free from defects for a period of 90 days from the date of purchase under normal use. If a product is defective during this period, we will at our option repair or replace the defective part or product. This limited warranty extends only to the original retail purchaser and is valid only when supplied with proof of purchase, or if received as a gift, when the registration is on file with Delta.

This limited warranty does not cover the following:

- Products purchased as floor models or samples.
- Items purchased on an “as-is” basis, as a second hand product, or as a resale product.
- Items purchased at a Final sale, a “Going out of Business” sale, or a Liquidation sale. This limited warranty gives you specific legal rights and you may also have other rights which vary from state to state.

This limited warranty gives you specific legal rights and you may also have other rights which vary from state to state.

**TO REGISTER YOUR PRODUCT** for important safety alerts and updates to your product please visit [www.deltachildren.com](http://www.deltachildren.com)

**TO REPORT A PROBLEM**, please log on to [www.deltachildren.com](http://www.deltachildren.com) and click the Consumer Care Tab, or contact us by phone at (646) 435-8726

Date of Purchase: \_\_\_\_\_ (you should also keep your receipt)

## EXTENDED WARRANTY

### DON'T MISS YOUR CHANCE TO BE COVERED FOR ALL OF LIFE'S MISHAPS!

With Delta's Extended Warranty, you're covered for mechanical failure from normal use or if your item stops working due to normal wear and tear, plus all those unexpected surprises.

## 2 YEARS OF PROTECTION

**For Additional Information:**

**Simply visit our Website, register your product, and add the Extended Warranty**

**<https://www.deltachildren.com/pages/product-registration>**

Extended Warranty only available in the following States: Arkansas, Colorado, Delaware, District of Columbia, Georgia, Idaho, Illinois, Indiana, Iowa, Kansas, Kentucky, Louisiana, Maryland, Michigan, Mississippi, Missouri, Nebraska, Nevada, New Hampshire, New York, North Carolina, North Dakota, Pennsylvania, Rhode Island, South Dakota, Tennessee, Utah, West Virginia

# Parts

**IMPORTANT!** Please remove all parts from the package and identify them before assembly.

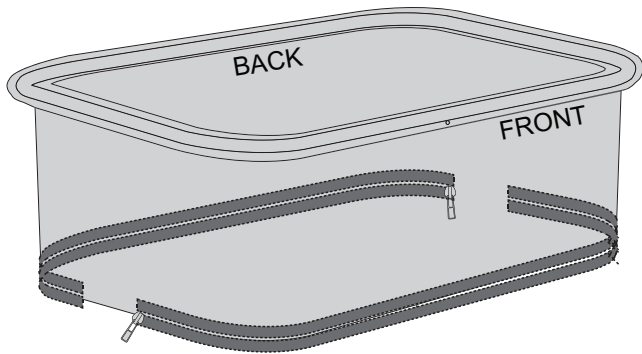

**Bassinet Fabric**

**Side Frame Stands**

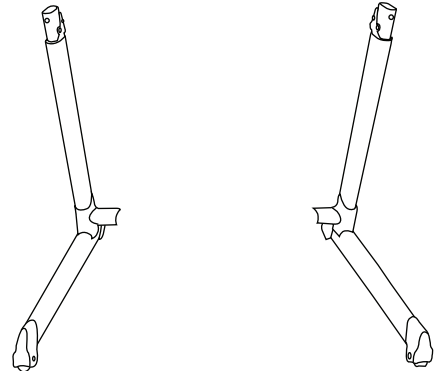

**(Left)**

**(Right)**

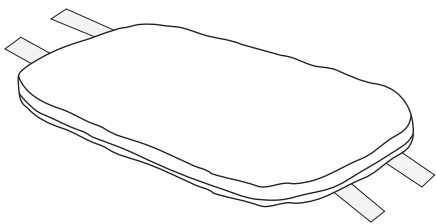

**Mattress Support Pad**

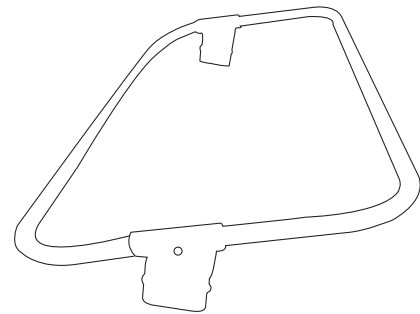

**Top Support Tube**



**Sheet**

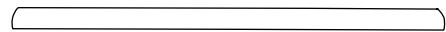

**Bottom Cross Support Bar**

## Hardware

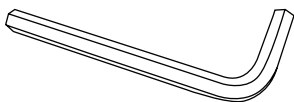

**Hex Wrench**



\*Screw is actual size to scale

**M8 Hex Screw (X4)**

# Assembly

## Bassinet Frame Assembly

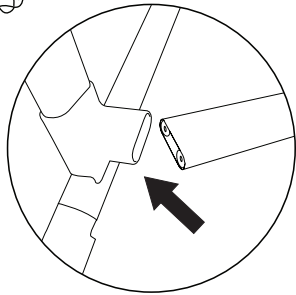
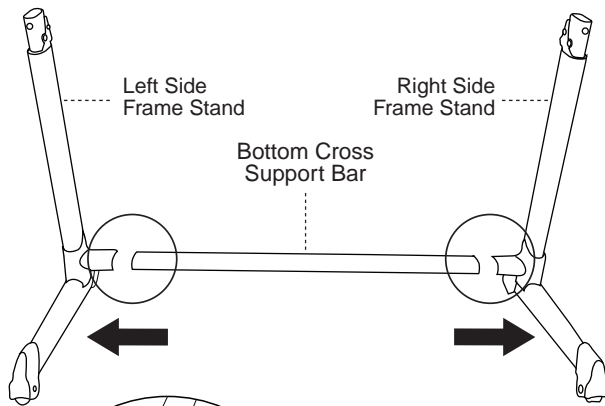

Fig. 1  
Insert support bar into  
side frame stand

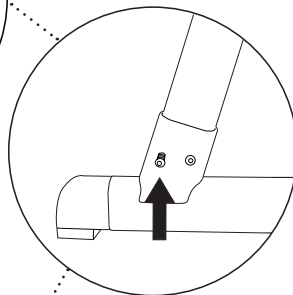

Fig. 1A  
Secure side frame  
stand and support  
tube with screw

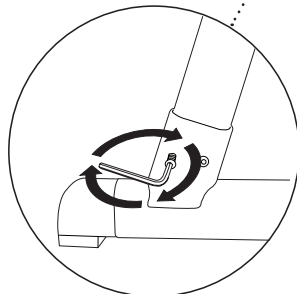

Fig. 1B  
Tighten screws with  
wrench clockwise

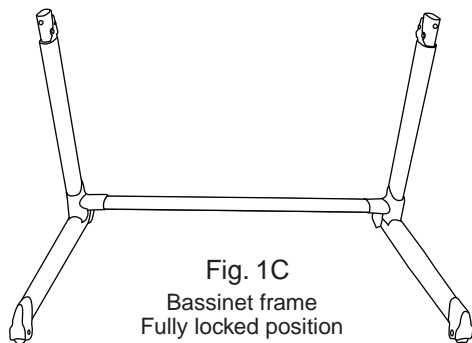

Fig. 1C  
Bassinet frame  
Fully locked position

1

- Insert support bar to the left side frame stand (Fig. 1). Secure with the two screws (Fig. 1A). Use the wrench to tighten screws in clockwise direction (Fig. 1B). Repeat for the right side frame stand. Make sure frame is in a fully locked position (Fig. 1C) pull outward on left and right side frames.

## Leg Extension

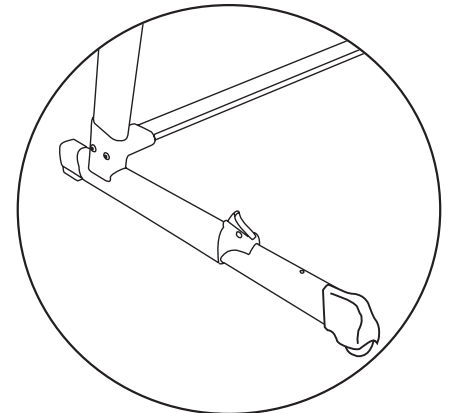
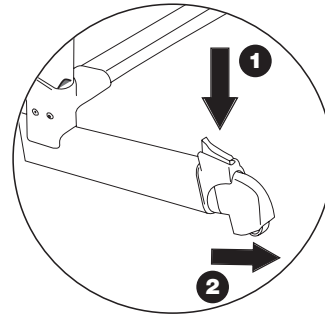

Fig. 2

2

- Fully extend both sides of the bassinet legs by pressing the button located on top of the bassinet legs 1 and pull outward 2 to fully extended position (Fig. 2)

# Bassinet Fabric Assembly

## STEP 1

Support Tube  
Side Buttons

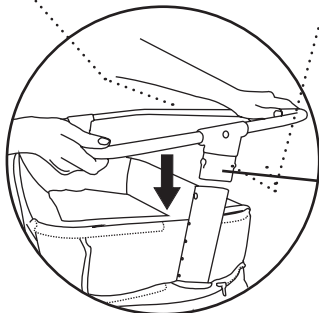

Fig. 3A

Insert both sides of the top support tube into the bassinet frame

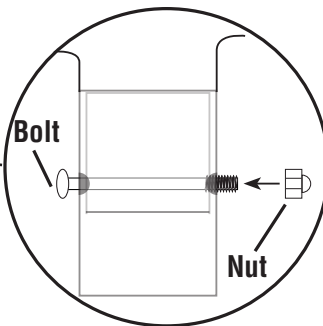
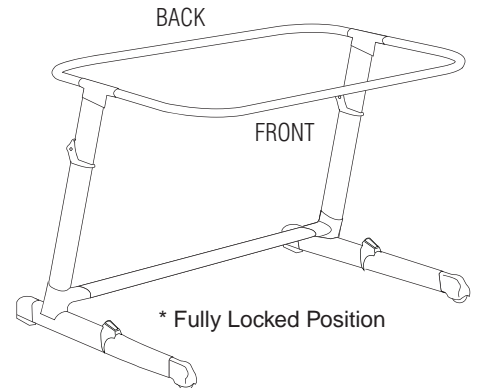
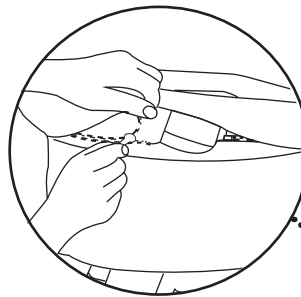
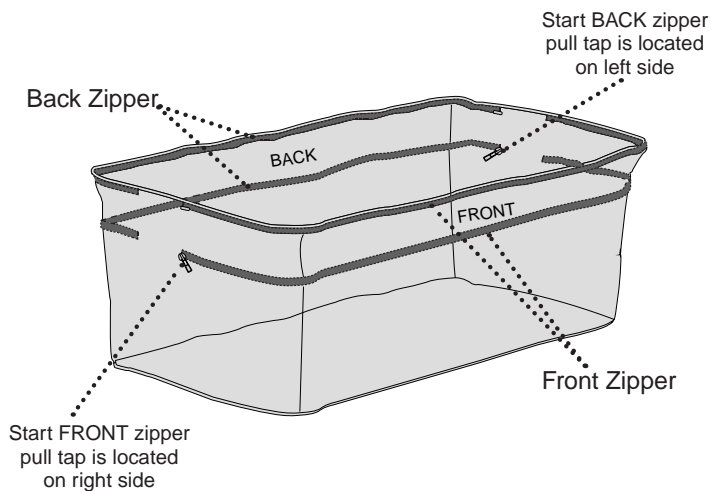

Fig. 3B



## STEP 2



Start FRONT zipper pull tap is located on right side

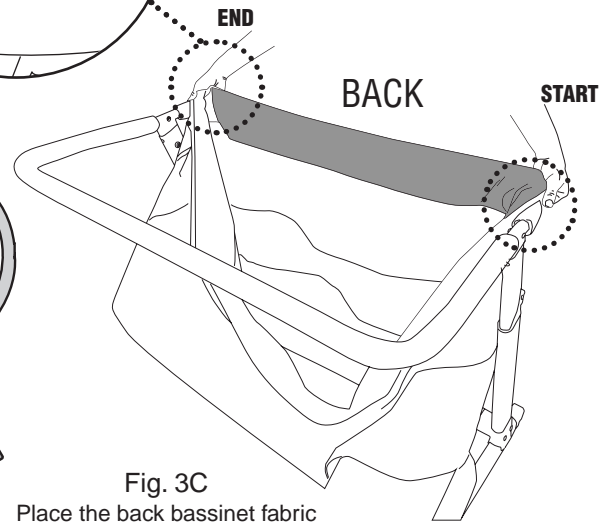
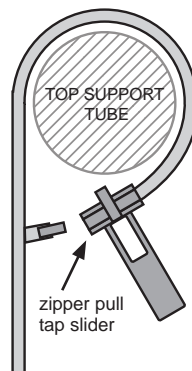

Fig. 3C

Place the back bassinet fabric to the back top support tube

3

**STEP 1:** Align top back support tube to the side frames. Insert both sides of the top support tube into the bassinet frame (Fig. 3A). Secure by inserting bolt through holes and screwing nut clockwise (Fig. 3B).

**STEP 2:** Place the back bassinet fabric over the back rail tube. Align and fasten zipper to top rail (Fig. 3C).

NOTE: Zipper pull tab slider located on left side.

# Bassinet Fabric Assembly

## STEP 3

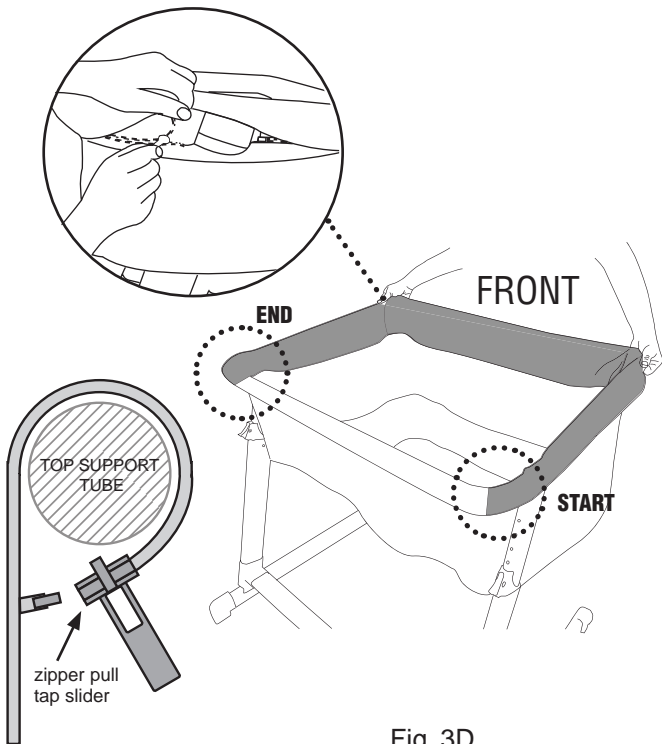

Fig. 3D  
Place the front bassinet fabric to the front top support tube

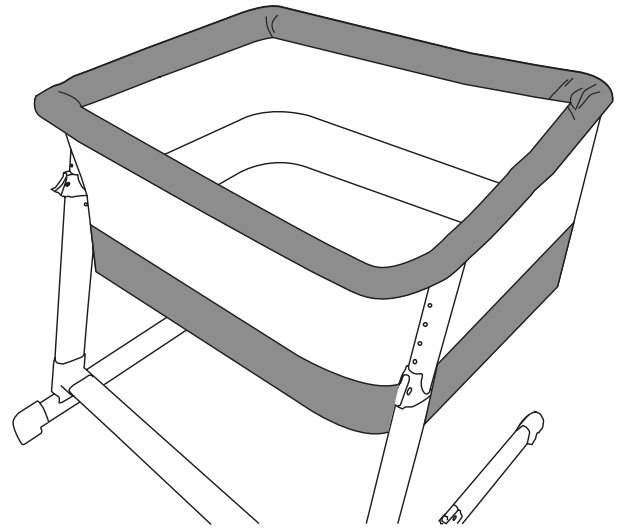
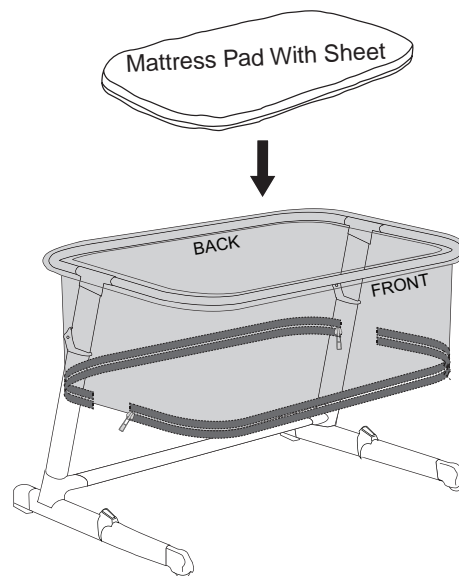

Fig. 3E  
Fabric Bassinet Fully Zipped

## STEP 4



3

**STEP 3:** Place the front bassinet fabric over the front rail tube. Align and fasten zipper to top rail (Fig. 3D) until fully zipped (Fig. 3E)

**STEP 4:** Place sheet over mattress support pad. Insert mattress support pad to sleeper.

**NOTE:** The mattress support pad should fully cover the bottom floor. No excess fabric should show on the edges.



# Height Adjustment

## STEP 1

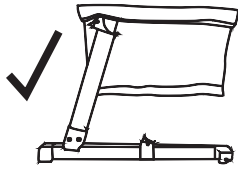

For Bassinet Mode ONLY

**WARNING: NEVER** adjust height with baby inside.

**NOTE:** To adjust height change sleeper mode to bassinet mode first.

**NOTE:** To adjust up or down you must unlock EACH SIDE separately.

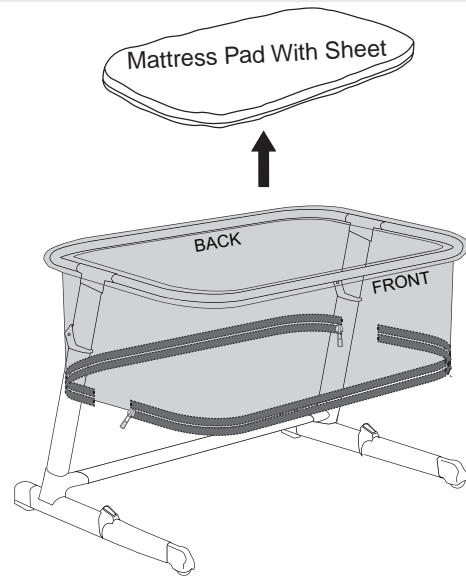

## STEP 2 & 3

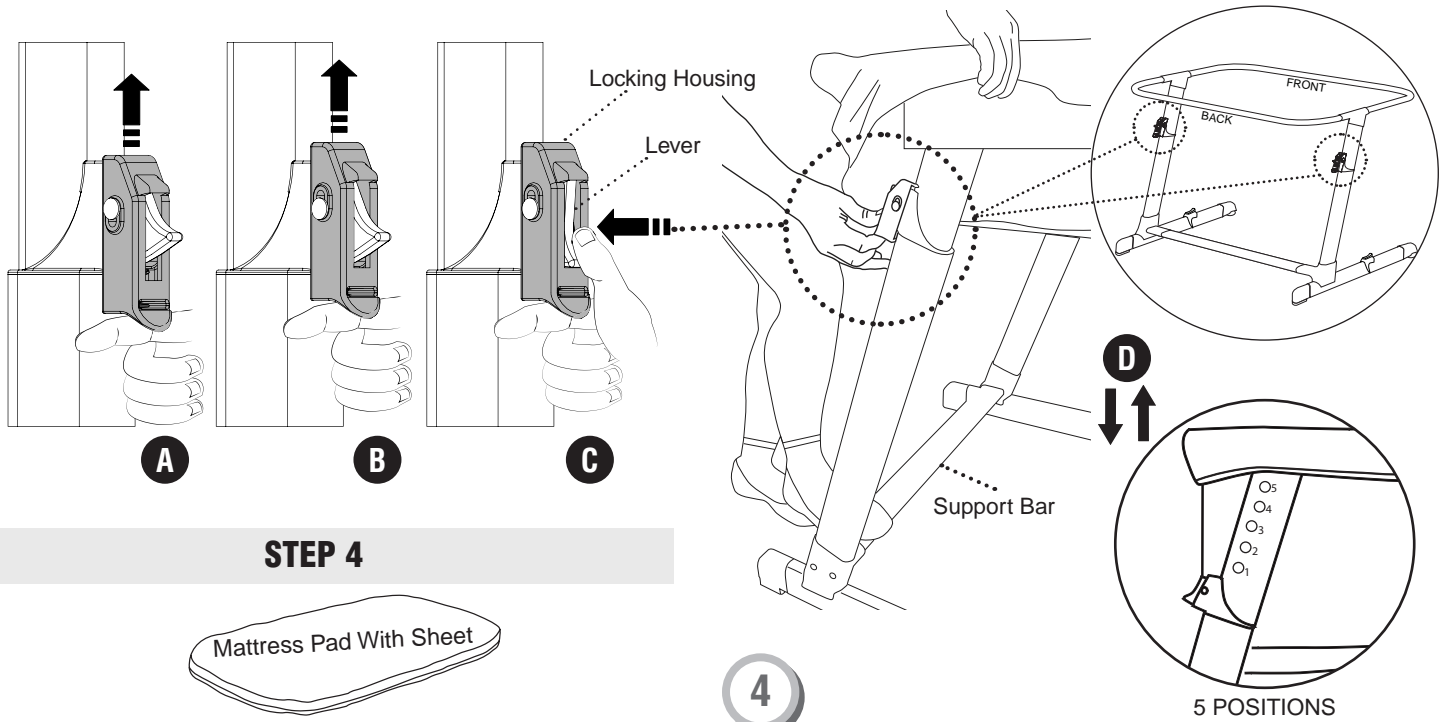

## STEP 4

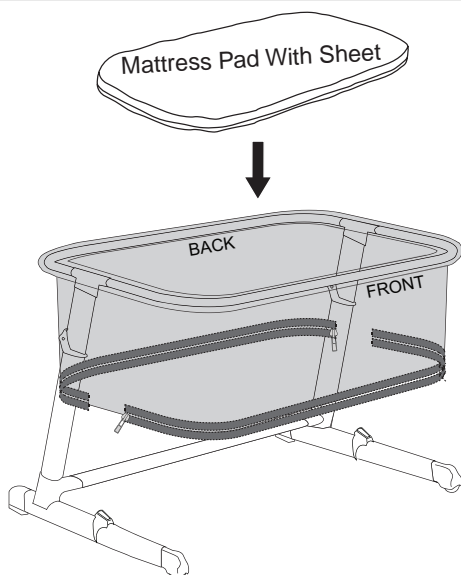

4

5 POSITIONS

**STEP 1:** Remove mattress support pad

**STEP 2:** Locate left side locking housing (A), push and hold up from underneath locking housing (B). Then press the lever inward (C) and move top rail up or down into desired position. There are 5 positions total (D).

**STEP 3:** Repeat STEP 2 on the right side.

**NOTE:** Make sure the bassinet is equally level.

**STEP 4:** Insert mattress pad

**NOTE:** The mattress support pad should fully cover the bassinet bottom. No excess fabric should show on the edges.

# Sleeper Mode Bassinet to Sleeper Mode Assembly

## STEP 1

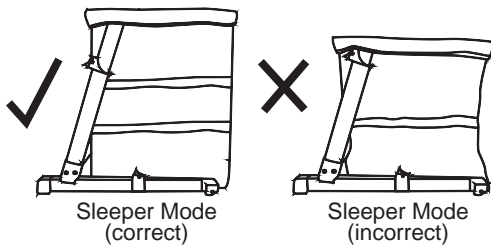

**WARNING: NEVER change modes with baby inside.**

**NOTE:** There are 5 positions. Sleeper mode should be in top position. Top position is 5th.

**NOTE:** To adjust up or down you must unlock EACH SIDE separately.

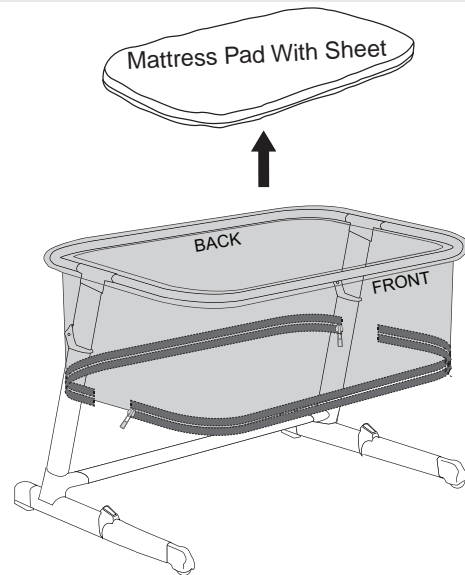

## STEP 2 & 3

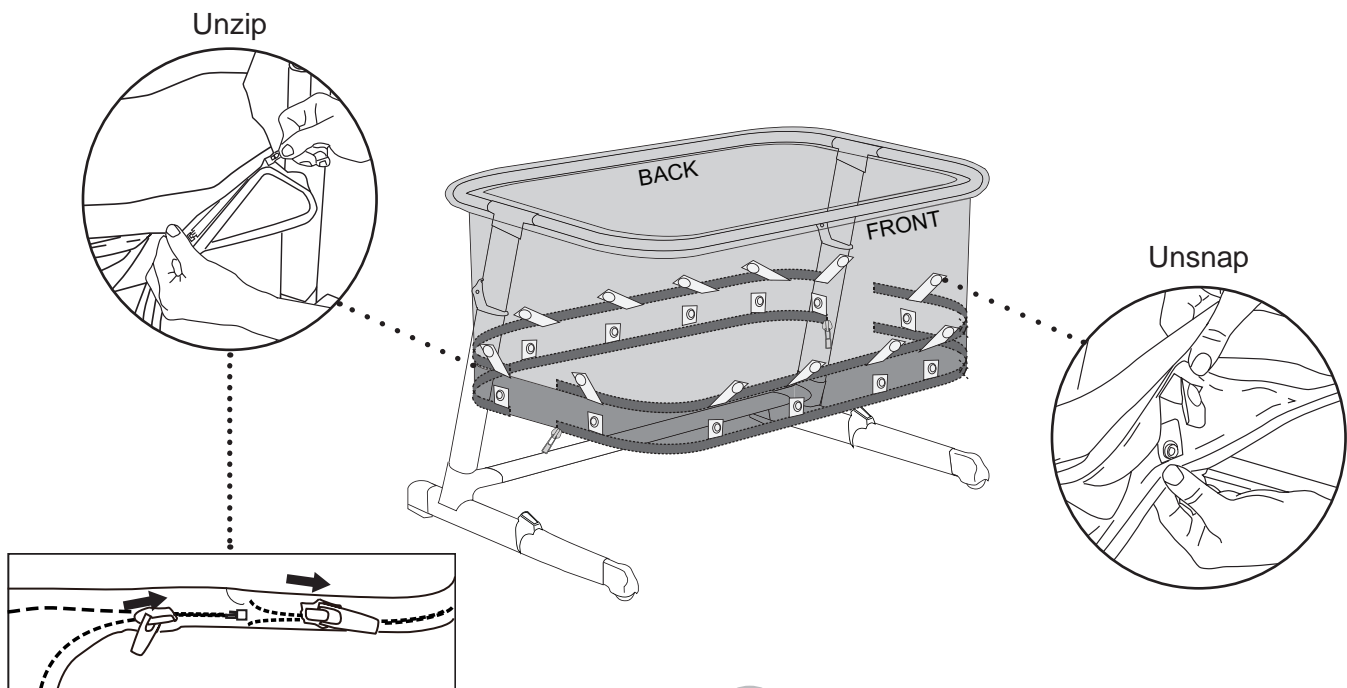

5

To convert to sleeper mode:

**STEP 1:** Remove mattress support pad

**STEP 2:** Fully unzip back and front zippers at the bottom of the bassinet.

**STEP 3:** Unsnap the straps on each side. There are 12 straps all around the bassinet (Snaps are located under bottom flap).

# Sleeper Mode Bassinet to Sleeper Mode Assembly

## STEP 4

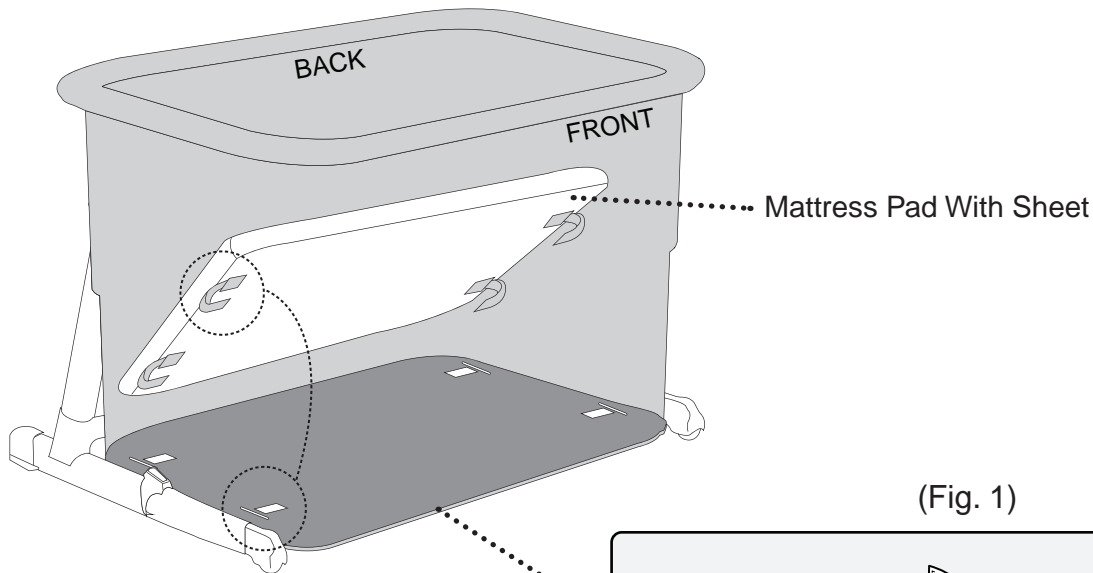

(Fig. 1)

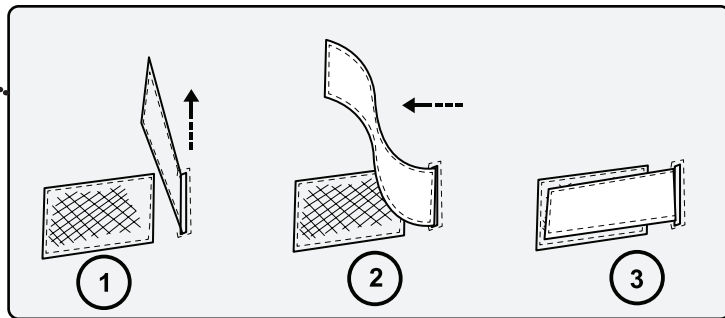

**STEP 4:** Pull the hook and loop straps through the slots at the bottom of the bassinet floor. Fasten straps as shown in (Fig. 1) underneath.

**WARNING:** Make sure both hook and loop straps are firmly attached by pulling upward on the mattress.

**NOTE:** Base bottom of the sleeper will rest on the floor once mattress support pad is placed.

**NOTE:** The mattress support pad should fully cover the bottom floor. No excess fabric should show on the edges.

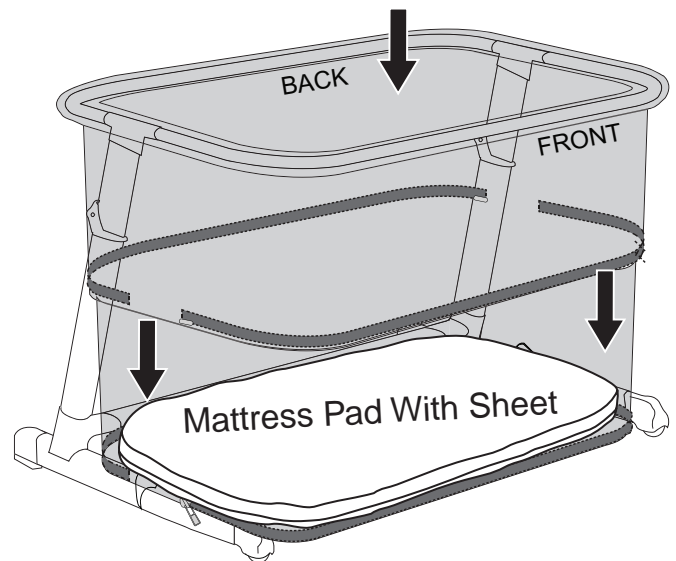

# Bassinet Mode Sleeper to Bassinet Mode Assembly

## STEP 1

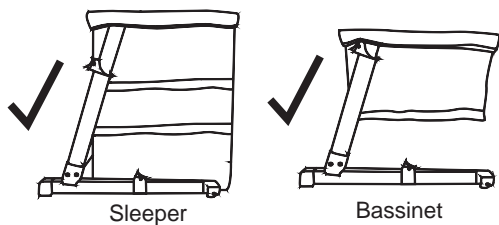

**WARNING: NEVER change modes with baby inside.**

**NOTE: To adjust up or down you must unlock EACH SIDE separately.**

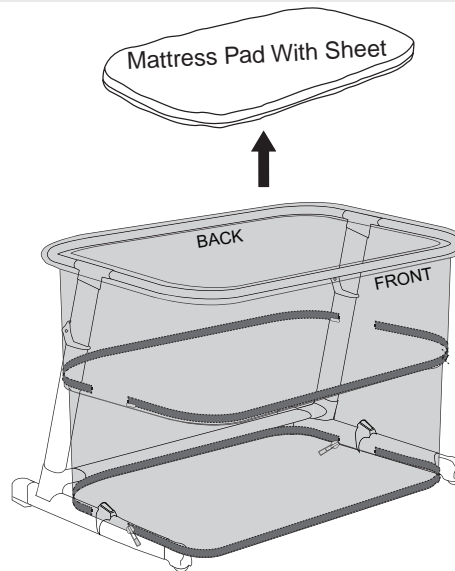

## STEP 2 & 3

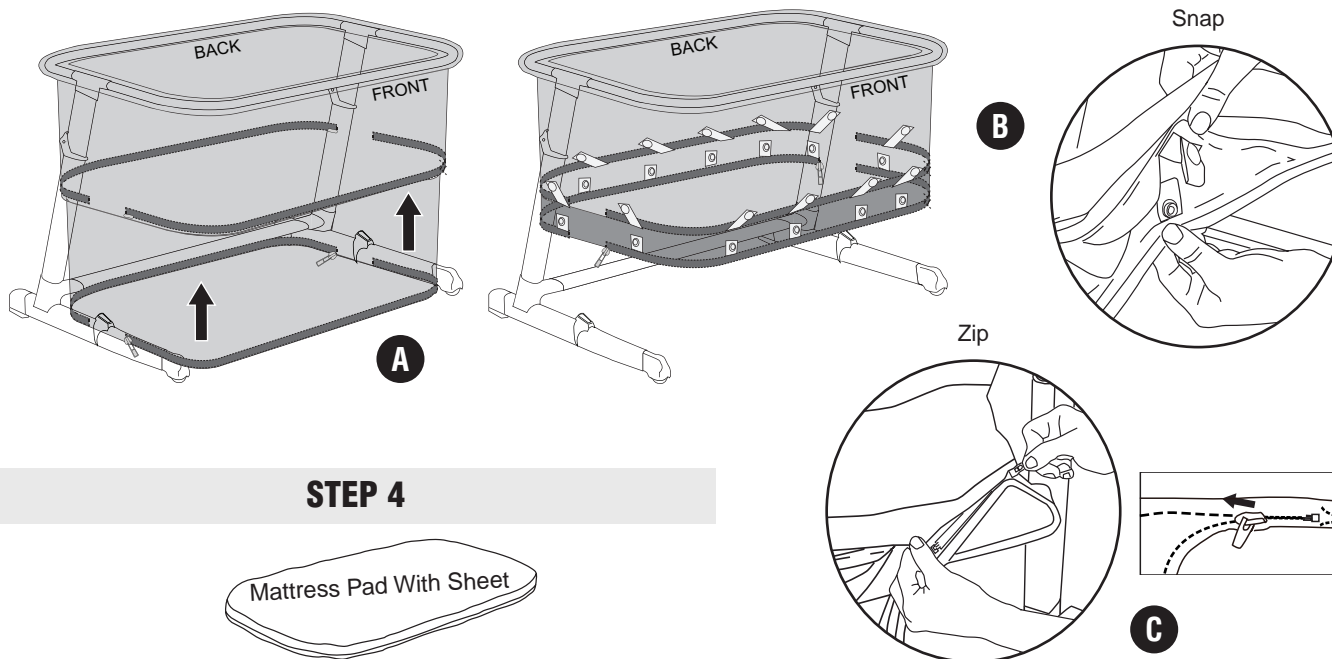

## STEP 4

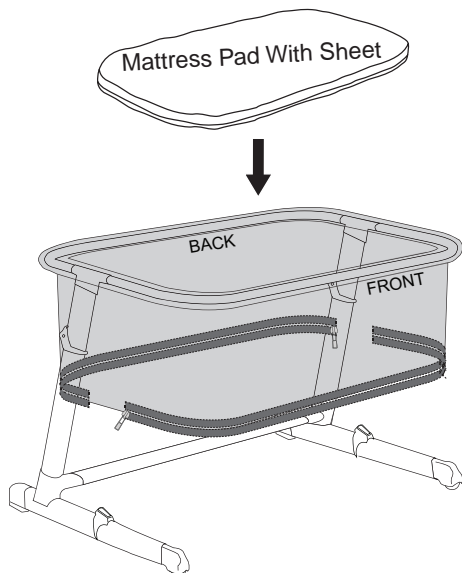

6

To convert to bassinet mode:

**STEP 1: Remove mattress support pad**

**STEP 2: Push up fabric from the bottom (A). Snap the straps on each side (B). There are 12 straps all around the bassinet (Snaps are located under bottom flap).**

**STEP 3: Fully zip back and front zippers at the bottom of the sleeper (C).**

**STEP 4: Place mattress support pad.**

**NOTE: The mattress support pad should fully cover the bassinet bottom. No excess fabric should show on the edges.**

# Disassembly

## Removing Fabric

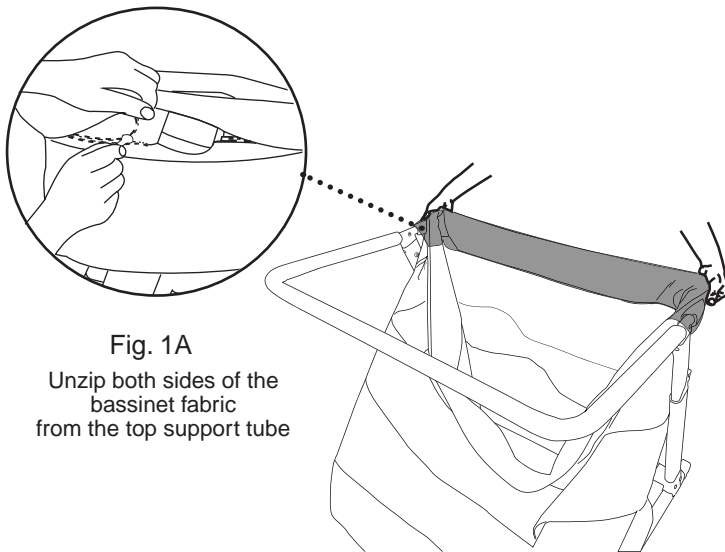
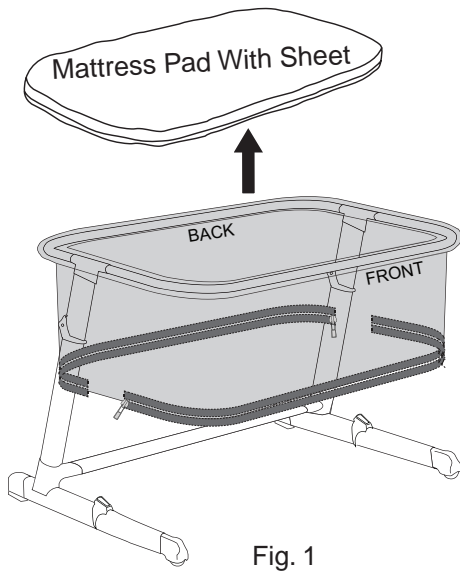

Unzip both sides of the bassinet fabric from the top support tube

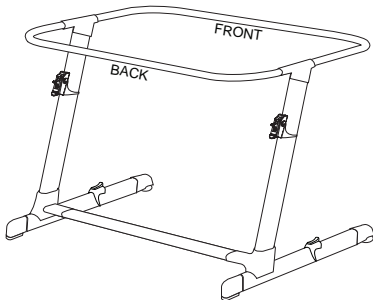

Bassinet Fabric Fully Removed

## Bassinet Frame Disassembly

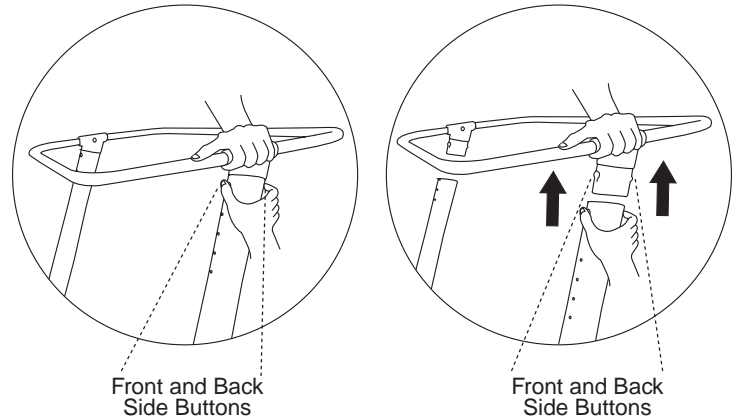

Press front and back side buttons on the support tube and lift upward to remove. Repeat on opposite side.

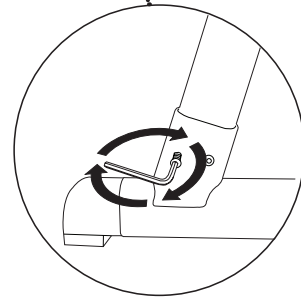
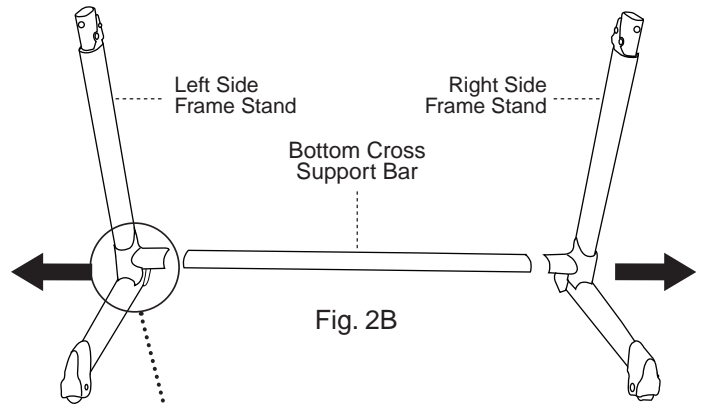

2

- Press front and back side buttons together and pull upward on tube to remove (Fig.2A).
- Press both side buttons on the support tube and lift upward to remove. Repeat on opposite side (Fig.2B). Repeat on the other side.
- Unscrew screws left and right side frame (Fig. 2C).

1

- Remove mattress support pad (Fig. 1)
- Unzip both sides of the bassinet fabric from the top rail (Fig.1A and Fig. 1B).

## Care and Maintenance

- Check bassinet for worn parts, torn material or stitching periodically.
- Replace or repair the parts as needed. Use Delta replacement parts.
- The bassinet fabric cover is machine washable. Wash them separately in cold water on the gentle cycle. Do not use bleach. Tumble dry separately on low heat and remove promptly.
- The frame may be wiped clean using a mild cleaning solution and a damp cloth. Do not use bleach. Do not use harsh or abrasive cleaners. Rinse clean with water to remove residue. Do not immerse the frame.
- Before each usage or assembly, inspect unit for damaged hardware, loose joints, missing parts or sharp edges. NEVER use this product if there are any loose or missing fasteners, loose joints, broken parts, or torn mesh/fabric. Check before assembly and periodically during use. Contact Simmons Customer Service Department at (646) 435-8726 for replacement parts, repair or instructions.







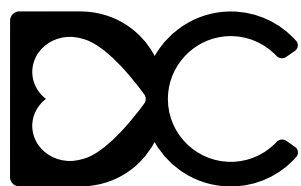

DELTACHILDREN

**Delta Children's Products Corp.**

114 West 26<sup>th</sup> Street  
New York, NY 10001  
646-435-8726  
[www.DeltaChildren.com](http://www.DeltaChildren.com)