

ULTRA LITE ADVENTURE STROLLER

Jeep®

INSTRUCTION MANUAL

13198

ADULT ASSEMBLY REQUIRED
STYLES AND COLORS MAY VARY



**⚠ WARNING:
CHOKING HAZARD**

Adult assembly required because of small parts. Keep assembly parts out of reach of children under 3 years.

Read all instructions BEFORE assembly and USE of product
KEEP INSTRUCTIONS FOR FUTURE USE.

Customer Experience Center
phone: (646)-435-8726
email: gcs@DeltaChildren.com



www.DeltaChildren.com

DCP-IM-03112019-F5

WARNING

WARNING: Please follow all of these instructions to ensure the safety of your child.
Keep these instructions for future reference.

WARNING: Failure to follow these instructions could result in serious injury or death.

- Avoid serious injury from falling or sliding out. **ALWAYS** insure that the child is properly positioned by using the safety harness according to these instructions. **ONLY** children who have developed enough upper body control to sit without leaning forward can use the front seat in the upright position.
- **NEVER** leave children unattended.

WARNING: CHOKING HAZARD Adult assembly required because of small parts.
Keep (assembly parts) out of reach of children under 3 years.

CAUTION: Purses, shopping bags, parcels, diaper bags or accessory items may change the balance of the stroller and cause hazardous unstable conditions.

TO PREVENT INJURY

- Make sure all body parts are clear of the stroller when folding and unfolding.
- The maximum weight that can be carried in the lower basket, and child tray, each is 3 lbs (1.36 kg). Excessive weight may cause a hazardous unstable condition to exist.
- Before allowing the children near the stroller, be certain the stroller is fully erect and latched in the open locked position.
- Use of the stroller with children weighing more than 50 pounds (22.62 kg) or over 42 inches (106.7 cm) tall, may cause a hazardous unstable condition to the stroller.
- **NEVER** use the stroller on stairways or escalators.
- **NEVER** allow your stroller to be used as a toy.
- **NEVER** use the stroller in conjunction with bicycles, skateboards, roller skates, or in-line skates. Please discuss using the jogging stroller with your health care provider prior to jogging use. We recommend that the child occupant needs to be 6 months of age, at the minimum, before use of the stroller.

Product features and decorations may vary from the photo.

CARE AND MAINTENANCE

- To clean the plastic parts on stroller use a mild cleaning solution with warm water on a sponge or damp cloth. Hand wash fabric with damp cloth and air dry. Do not use bleach.
- To keep your stroller wheels from squeaking, use silicone or graphite based lubricant.
- Check your stroller for loose screws, worn parts, torn material or stitching on a regular basis. Replace or repair parts as needed, discontinue use of stroller if it should become damaged or malfunctions.



Please DO NOT return this product to the store.

If you experience any difficulty with assembly, missing parts or use, please DO NOT return this item to the store. Retail stores are unable to properly assist you. Contact our Customer Service Department directly for assistance
646-435-8726



www.DeltaChildren.com • gcs@DeltaChildren.com
©2019 Delta Children's Products, Inc. New York, NY 10001



EXTENDED WARRANTY

DON'T MISS YOUR CHANCE TO BE COVERED FOR ALL OF LIFE'S MISHAPS!

With Delta's Extended Warranty, you're covered for mechanical failure from normal use or if your item stops working due to normal wear and tear, plus all those unexpected surprises.

2 YEARS OF PROTECTION

For Additional Information:

Simply visit our Website, register your product, and add the Extended Warranty

<https://www.deltachildren.com/pages/product-registration>

Extended Warranty only available in the following States: Arkansas, Colorado, Delaware, District of Columbia, Georgia, Idaho, Illinois, Indiana, Iowa, Kansas, Kentucky, Louisiana, Maryland, Michigan, Mississippi, Missouri, Nebraska, Nevada, New Hampshire, New York, North Carolina, North Dakota, Pennsylvania, Rhode Island, South Dakota, Tennessee, Utah, West Virginia

Parts

IMPORTANT! Please remove all parts from the package and identify them before assembly.

IMPORTANT! Before assembly and each use, inspect this product for damaged hardware, loose joints, missing parts, or sharp edges. NEVER use if any parts are missing or broken. Contact manufacturer for replacement parts and instructions if needed. Never substitute parts. **IMPORTANT!** Adult assembly is required.



Stroller Frame



Child Bar
Part # 50340



Front Wheels
Part # 50341

Assembly

WARNING: Care must be taken when folding and unfolding the stroller to prevent finger entrapment.

Remove stroller from box. The front wheels need to be installed prior to use.



Attaching front wheels
Fig. 1

- First, insert front wheels (Fig. 1)

Assembly

Fig. 1A

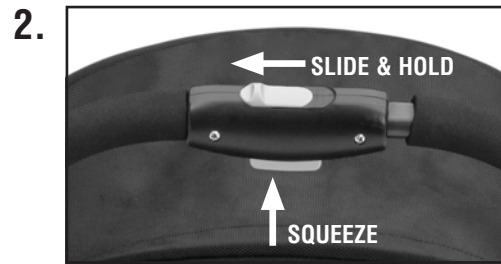
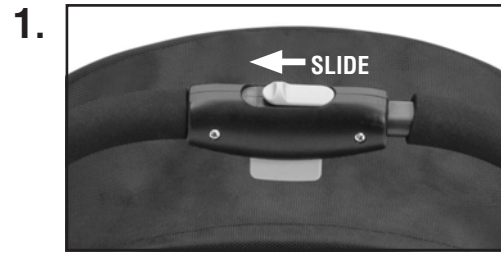

Fig. 1B

1

Opening Stroller

- Second, open the stroller.

A dual action is needed to open the stroller (Fig.1A).

Action 1: Slide from right to left the unlock tab with your thumb and hold.

Action 2: While squeezing bottom button and holding unlock tab, pull back and up stroller handle into a fully open position (Fig. 1B).

Note: The stroller is in a fully locked position when stroller clicks. Prior to placing your child into the stroller, test to make sure stroller is in a fully opened and locked position.

Assembly



Insert Both Sides To Attach
Fig. 2

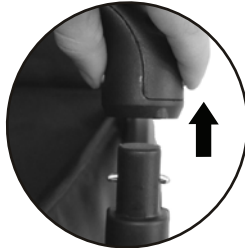

Squeeze Both Tabs To Remove
Fig. 2A

2

Attaching / Removing Child Bar

To Attach Child Bar:

- Insert both sides of the child bar into the bottom of the child posts (Fig. 2) until child bar “CLICKS” into a fully locked position.

Note: Pull upward on the child bar to ensure that the child bar is securely locked.

To Remove Child Bar:

- Squeeze tabs inward located on both sides of the child bar and lift upward until child bar is fully removed (Fig. 2A).

Setup and Use

BACK WHEELS



Fig. 3B

Push downward on brake
lever to lock stroller
on both sides



Fig. 3C

Push upward under brake
lever to unlock stroller
on both sides

3

WARNING: Always lock brakes when the stroller is not being pushed so that the stroller will not roll away. Never leave stroller unattended on a hill or incline as the stroller may slide down the hill.
WARNING: NEVER leave child unattended in stroller.

Back Wheel Brakes

- **To engage brakes:** Apply light downward pressure to each brake lever (Fig. 3B) Check to make sure the brakes are in a fully locked position, making sure stroller will not move when pushed.
- **To release brakes:** Gently lift up under each brake lever (Fig. 3C).

Setup and Use

RECLINE POSITION
Fig. 4

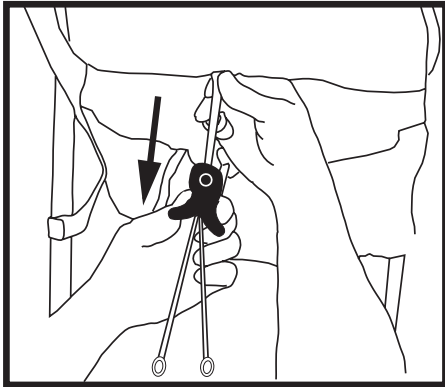

UPRIGHT POSITION
Fig. 4A

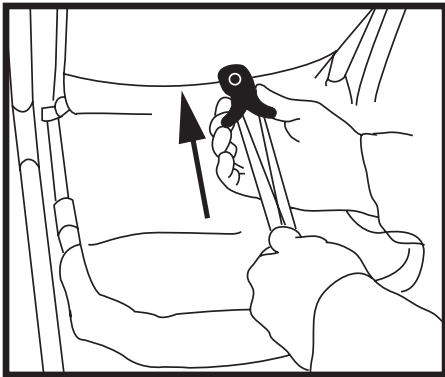

4

Seat Back Adjustment

- **Recline Position:** To place seat in a recline position, squeeze both sides on cord housing and pull away (Fig. 4)
- **Upright Position:** To return to an upright position, hold bottom cord loops while squeezing cord housing upwards toward backseat (Fig. 4A)



OPEN CANOPY
Fig. 5



CLOSE CANOPY
Fig. 5A

5

Canopy Adjustment

- To open canopy, push forward on the front frame of the canopy (Fig. 5).
- To close canopy, push on the front edge backward until canopy is all the way collapsed (Fig. 5A).

ADJUSTABLE FOOTREST
Fig. 6



6

Foot Rest Adjustment

- **To adjust foot rest:** Pull lever located underneath footrest forward and rotate upward or downward to adjust to its desired position (Fig. 6).

Securing Child

Before Placing your Child in Stroller:

Close Canopy. Press both brake pedals down until they “click” into the locked position.

Make sure the brake pedals are pressed down completely.

Always set both brake pedals when parking the stroller.

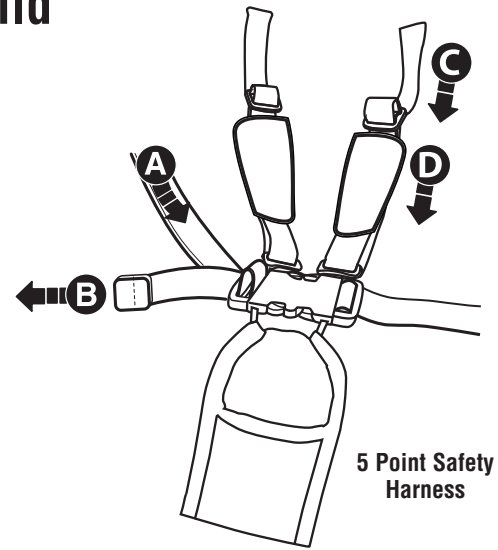
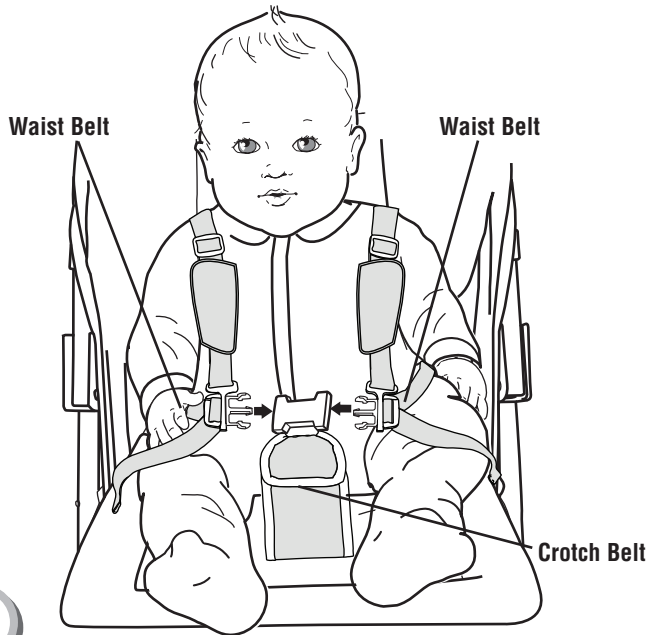

TIGHTEN

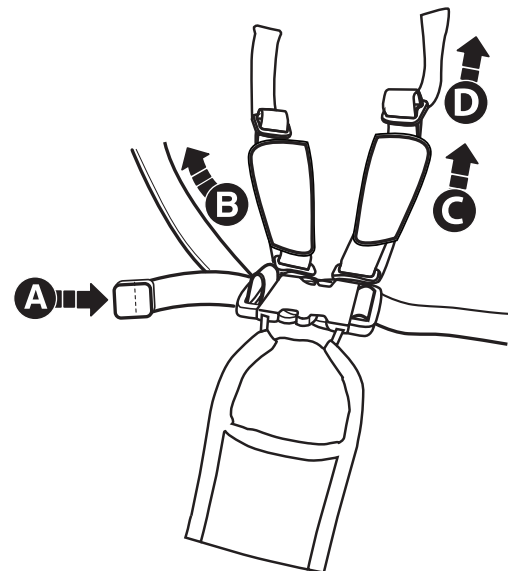

LOOSEN

1

Securing Child

- Place your child in the stroller. Position the crotch belt between your child's legs.
- Pull shoulder straps over child's arm and shoulder and fasten **both** strap ends to the restraint system.
- Fasten **both** waist belts to the buckle on each side of the crotch belt. Make sure you hear a “click” on both sides.
- Check to be sure the restraint system is securely attached by pulling it away from your child. The restraint system should remain attached.

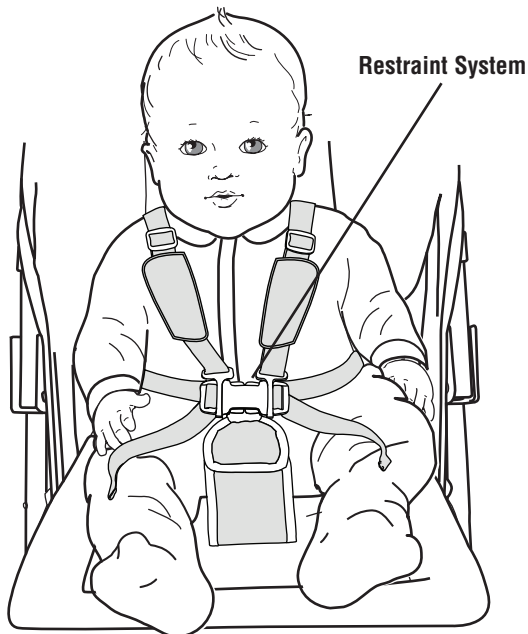

2

- Tighten each waist belt and shoulder strap so that the restraint system is snug against your child.
Please refer to the next section for instructions to tighten the waist belts.

3

To tighten the waist belts and shoulder straps:

- Feed the anchored end of a waist belt up through the buckle to form a loop **A**. Pull the free end of the waist belt **B**.
- Repeat this procedure to tighten the other waist belt.
- Feed the top end of the shoulder strap through the plastic stay to form a loop **C**. Pull the bottom end down to tighten the strap **D**.
- Repeat this procedure to tighten the other shoulder strap.

To loosen the waist belts and shoulder straps:

- Feed the free end of the waist belt up through the buckle to form a loop **A**. Enlarge the loop by pulling on the end of the loop toward the buckle. Pull the anchored end of the waist belt to shorten the free end of the waist belt **B**.
- Repeat this procedure to loosen the other waist belt.
- Feed the bottom end of the shoulder strap through the plastic stay to form a loop **C**. Pull the top end up to loosen the strap **D**.
- Repeat this procedure to loosen the other shoulder strap.

Please note: After adjusting the restraint system to fit your child, make sure you pull on it to be sure it is securely fastened.

Fold and Store

Fig. 7

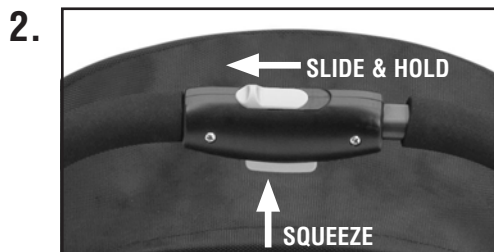
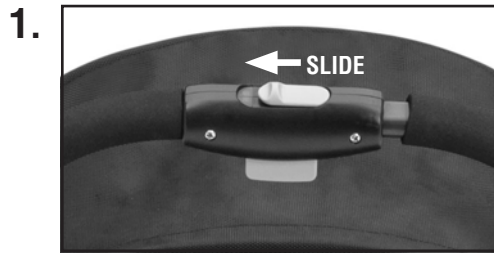

Fig. 7A

7

Folding Stroller

WARNING: Care must be taken when folding and unfolding the stroller to prevent finger entrapment.

Note: Canopy must be closed.

A dual action is needed to fold the stroller (Fig.7).

Action 1: Slide from right to left the unlock tab with your thumb and hold.

Action 2: While squeezing bottom button and holding unlock tab, pull back and up stroller handle before pressing handle downward into a fully close position (Fig. 7A).

Note: Pull upward on stroller handle to make sure stroller is in a fully close position



Delta Children's Products Corp.

114 West 26th Street
New York, NY 10001

646-435-8726

www.DeltaChildren.com