

LX PLUS SIDE X SIDE STROLLER



INSTRUCTION MANUAL

ADULT ASSEMBLY REQUIRED

STYLES AND COLORS MAY VARY

11709



**▲ WARNING:
CHOKING HAZARD**

Adult assembly required because of small parts. Keep assembly parts out of reach of children under 3 years.

Read all instructions BEFORE assembly and USE of product. KEEP INSTRUCTIONS FOR FUTURE USE.

www.DeltaChildren.com

Customer Service: (646) 435-8726

DCP-IM-04302019-F3

Consumer Information



WARNING

Prevent serious injury from falls or sliding out:

- ALWAYS use the restraint system.
- Only children who have developed enough upper body control to sit without leaning forward can use the front seat in the upright position.
- NEVER leave child unattended.
- DO NOT use the storage bag to carry children.

To prevent product from tipping over:

- DO NOT exceed the maximum storage weight limit of 3 lbs (1.36 kg) in the storage bag or canopy pouch.
- DO NOT exceed the maximum storage weight limit of 3 lbs (1.36 kg) in the cup holder.
- DO NOT place additional items on this product, except as recommended in the instructions.

To prevent injury:

- Make sure all body parts are clear of the stroller when folding and unfolding.
- DO NOT place hot liquids in the cup holder. Hot liquids can burn your child.

- Please read these instructions before assembly and use of this product.
- Adult assembly is required.
- Use only for a child who weighs less than 35 lbs (15.88 kg).
- Maximum weight limit for the storage bag and canopy pouch is 3 lbs (1.36 kg).
- Maximum weight limit for the cup holder is 3 lbs (1.36 kg).
- Product features and decorations may vary from the photo.

Care

- The plastic parts may be wiped clean using a mild cleaning solution and damp cloth. Hand wash fabric with damp cloth and air dry. Do not use bleach.
- To keep your stroller wheels from squeaking, use a silicone or graphite based lubricant.

Manufactured for and distributed by:



114 West 26th Street, New York, NY 10001



Customer Service

(646)-435-8726

www.DeltaChildren.com

MADE IN CHINA



Please DO NOT return this product to the store.

If you experience any difficulty with assembly, missing parts or use, please DO NOT return this item to the store. Retail stores are unable to properly assist you. Contact our Customer Service Department directly for assistance

(646) 435-8726

www.DeltaChildren.com • gcs@deltachildren.com
©2019 Delta Children's Products, Inc. New York, NY 10001



EXTENDED WARRANTY

DON'T MISS YOUR CHANCE TO BE COVERED FOR ALL OF LIFE'S MISHAPS!

With Delta's Extended Warranty, you're covered for mechanical failure from normal use or if your item stops working due to normal wear and tear, plus all those unexpected surprises.

2 YEARS OF PROTECTION

For Additional Information:

Simply visit our Website, register your product, and add the Extended Warranty

<https://www.deltachildren.com/pages/product-registration>

Extended Warranty only available in the following States: Arkansas, Colorado, Delaware, District of Columbia, Georgia, Idaho, Illinois, Indiana, Iowa, Kansas, Kentucky, Louisiana, Maryland, Michigan, Mississippi, Missouri, Nebraska, Nevada, New Hampshire, New York, North Carolina, North Dakota, Pennsylvania, Rhode Island, South Dakota, Tennessee, Utah, West Virginia

Parts

IMPORTANT! Please remove all parts from the package and identify them before assembly.

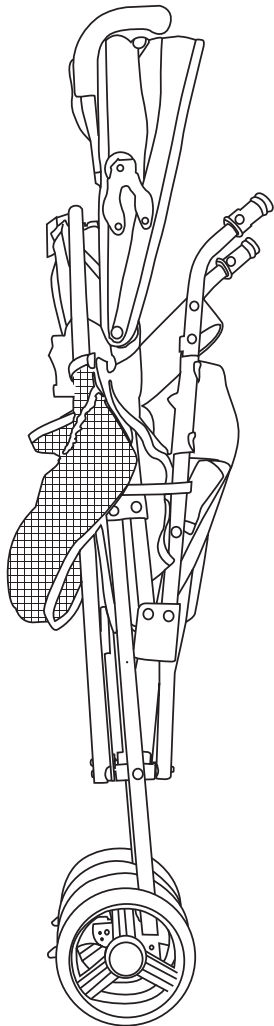

Stroller

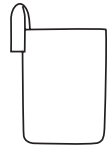

1 Cup Holder

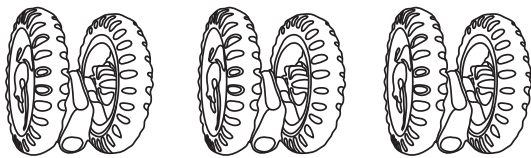

3 Front Wheel Assemblies

Assembly

IMPORTANT! Before assembly or each use, inspect this product for damaged hardware, loose joints, missing parts or sharp edges. DO NOT use if any parts are missing or broken. Contact manufacturer for replacement parts and instructions if needed. Never substitute parts.

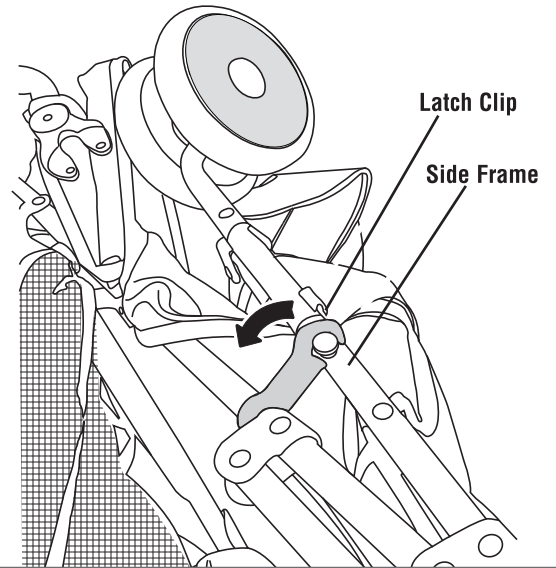

- Locate the latch clip on the side frame of the stroller.
- Pull to release the latch clip.

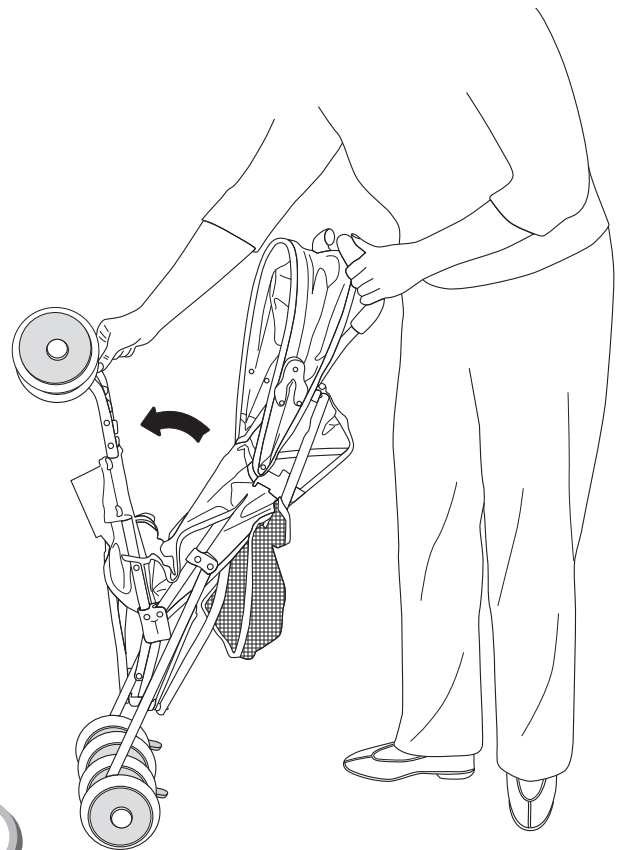

- Position the stroller upright on its rear wheels.
- Grasp a handle with one hand. With your other hand, push down on the front of the stroller to open.

Assembly

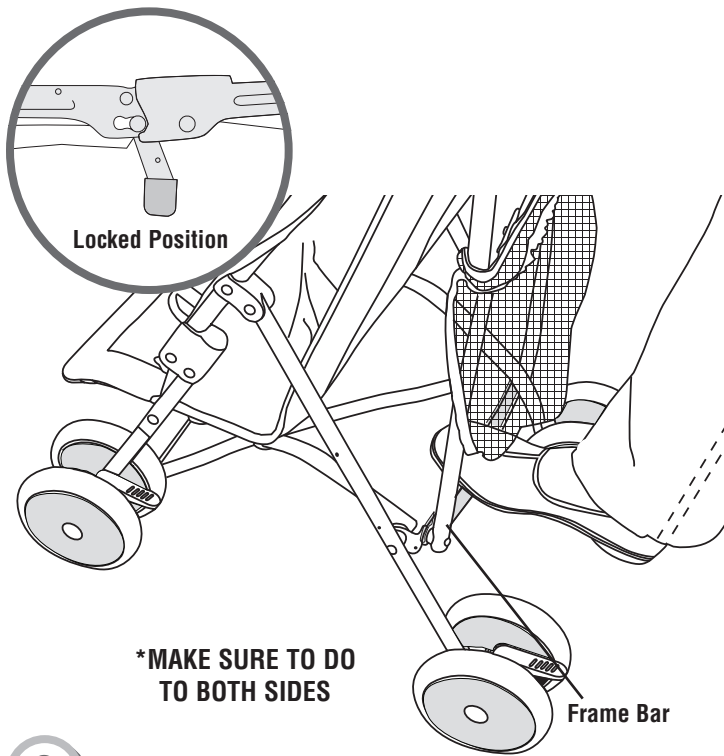

3

- With your foot, press down on the frame bar until it “clicks” into place.
- Check to be sure the stroller is locked open by pulling up on the frame bar.

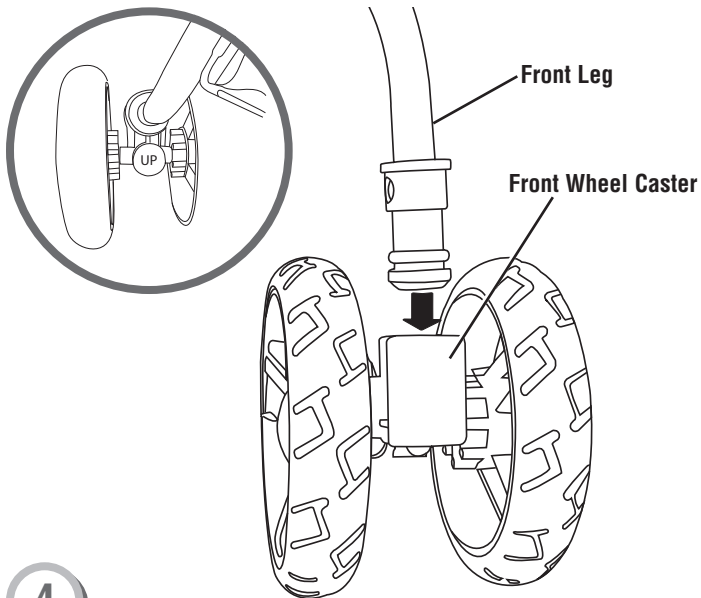

4

Front Wheel Assembly

- With the word UP facing toward the front leg, slide the front wheel caster onto a front leg. Make sure you hear a “click”.
- Pull on the front wheel assembly to make sure it is securely attached to the front leg.
- Repeat this procedure to attach the other front wheel assemblies.

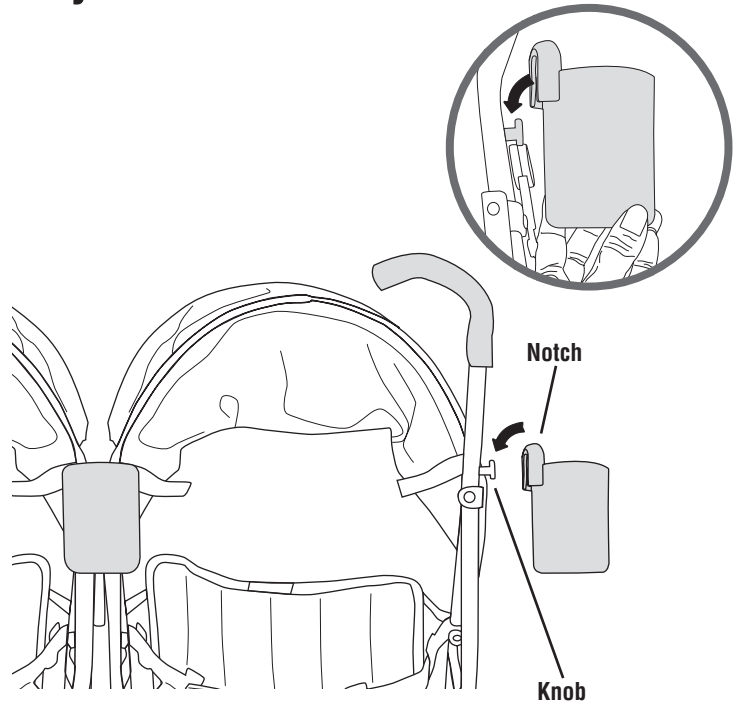

5

Attaching Cup Holder

- Locate the knob on the center or sides of the stroller.
- Fit the notch in the cup holder over the knob on the side rail and push down until you hear a “click”. Pull up on the cup holder to be sure it is secure.

Setup and Use

WARNING

Prevent serious injury from falls or sliding out:

- ALWAYS use the restraint system.
- Only children who have developed enough upper body control to sit without leaning forward can use the front seat in the upright position.
- NEVER leave child unattended.
- DO NOT use the storage bag to carry children.

To prevent product from tipping over:

- DO NOT exceed the maximum storage weight limit of 3 lbs (1.36 kg) in the storage bag or canopy pouch.
- DO NOT exceed the maximum storage weight limit of 3 lbs (1.36 kg) in the cupholder.
- DO NOT place additional items on this product, except as recommended in the instructions.

To prevent injury:

- Make sure all body parts are clear of the stroller when folding and unfolding.
- DO NOT place hot liquids in the cup holder. Hot liquids can burn your child.

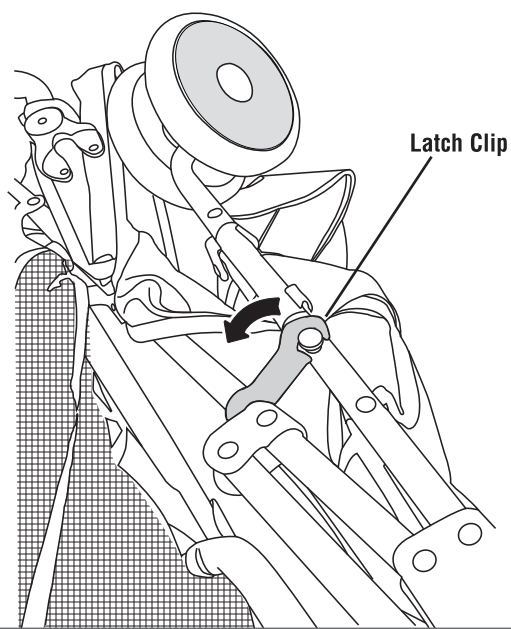

1

To Unfold

- Locate the latch clip on the side of the stroller.
- Pull to release the latch clip on the side of the stroller.

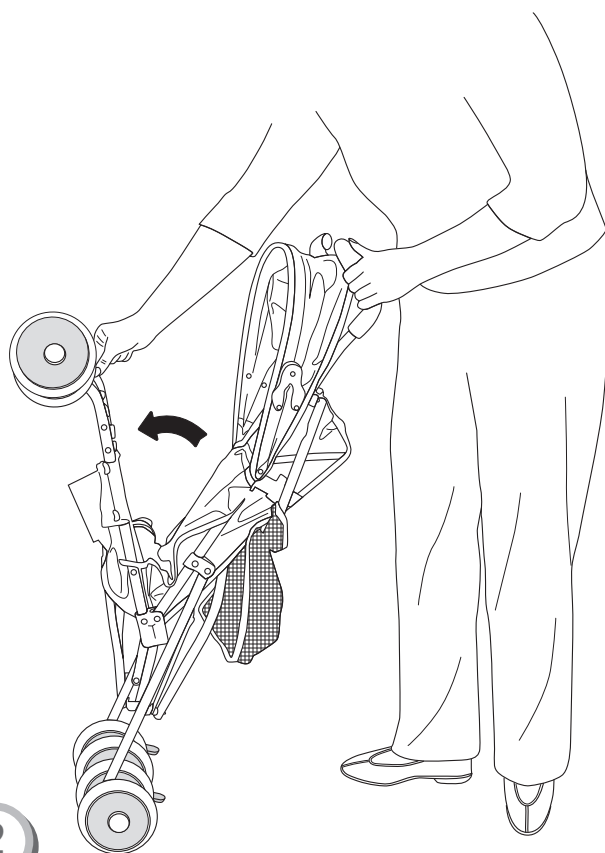

2

- Grasp a handle with one hand. With your other hand, push down on the front leg. Pull the stroller apart.

Setup and Use

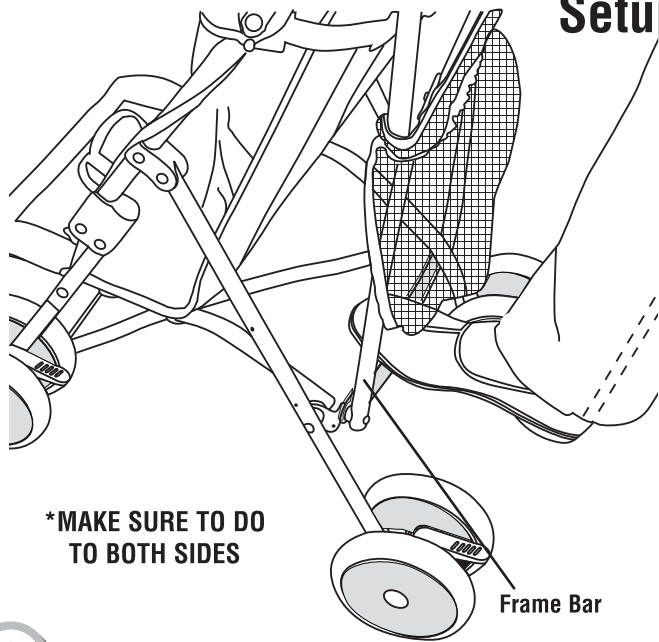

***MAKE SURE TO DO TO BOTH SIDES**

Frame Bar

3

- With your foot, press down on the frame bar until it “clicks” into place.
- Pull up on the frame bar to make sure it is locked.

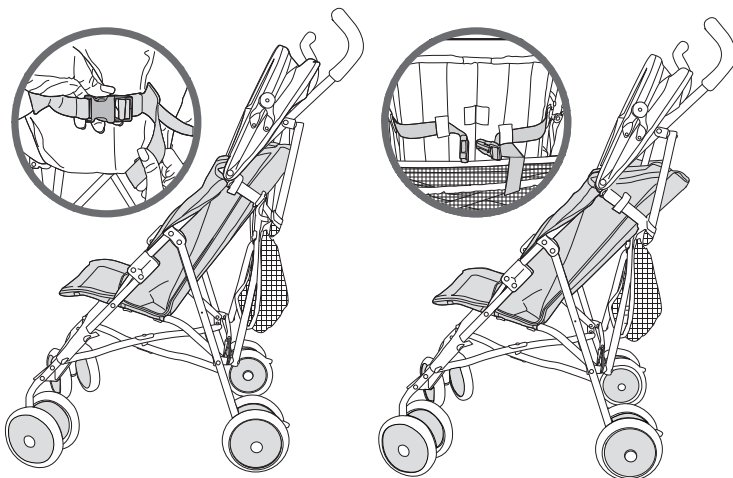

4

UPRIGHT

RECLINE

Seat Back Adjustment

- The seat back straps can be adjusted to multiple positions for baby's comfort.
- For upright positions, fasten the seat back straps on the back of the stroller. Pull free end of the strap to increase the incline of the upright position. Loosen the strap to decrease the incline position.
- For the recline position, unfasten the seat back straps on the back of the stroller.

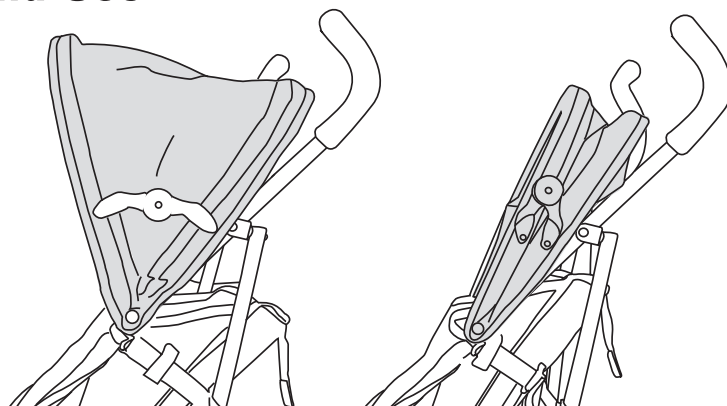

5

CANOPY OPEN

CANOPY CLOSED

Canopy Adjustment

- The canopy can be adjusted to the open or closed position.

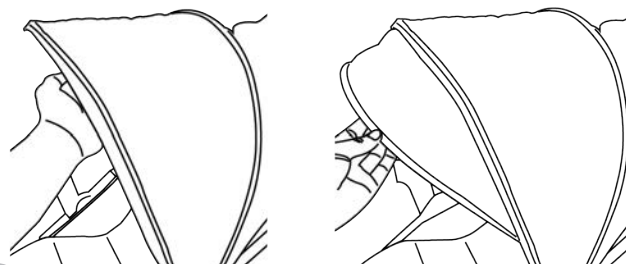

6

Sun Visor

- To open the sun visor: grab front edge of sun visor under canopy and pull down and rotate forward until fully extended.

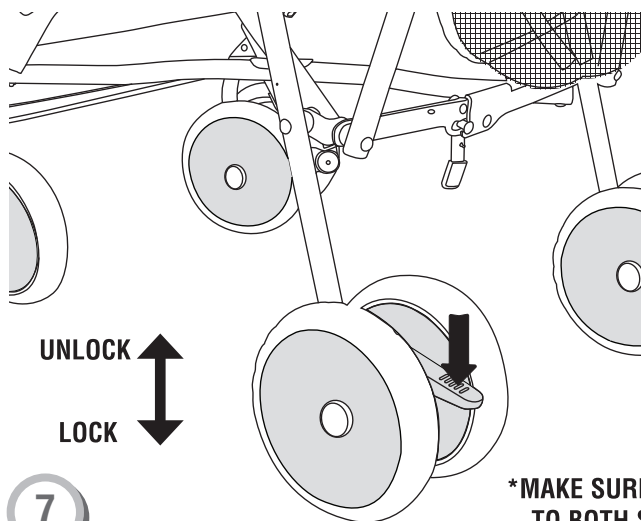

7

***MAKE SURE TO DO TO BOTH SIDES**

Rear Wheel Brakes

To lock the rear wheel brakes:

- Press **both** brake pedals down until they “click” into the locked position. **Make sure the brake pedals are pressed down completely.**
- Always set both brake pedals whenever you park the stroller.

To unlock the rear wheel brakes:

- Lift both brake pedals until they “click” into the unlocked position.

Securing Child

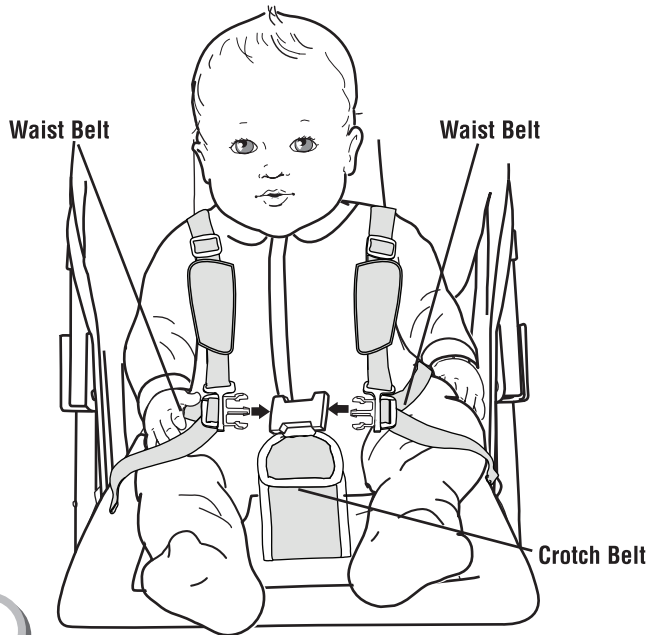

1

Securing Child

- Place your child in the stroller. Position the crotch belt between your child's legs.
- Pull shoulder straps over child's arm and shoulder and fasten **both** strap ends to the restraint system.
- Fasten **both** waist belts to the buckle on each side of the crotch belt. Make sure you hear a "click" on both sides.
- Check to be sure the restraint system is securely attached by pulling it away from your child. The restraint system should remain attached.

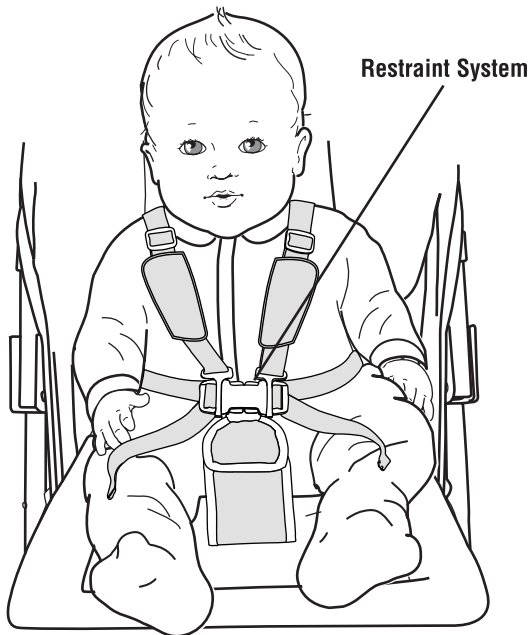

2

- Tighten each waist belt and shoulder strap so that the restraint system is snug against your child.
Please refer to the next section for instructions to tighten the waist belts.

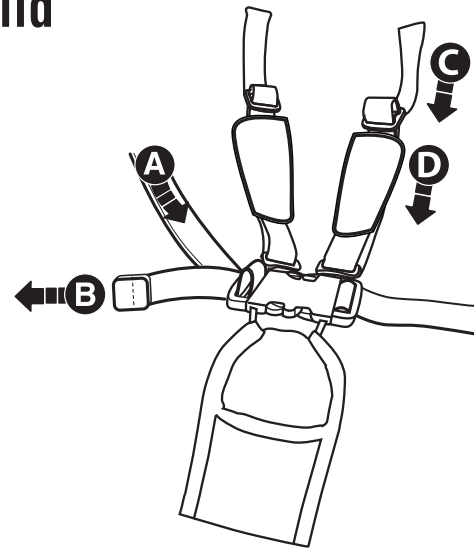

TIGHTEN

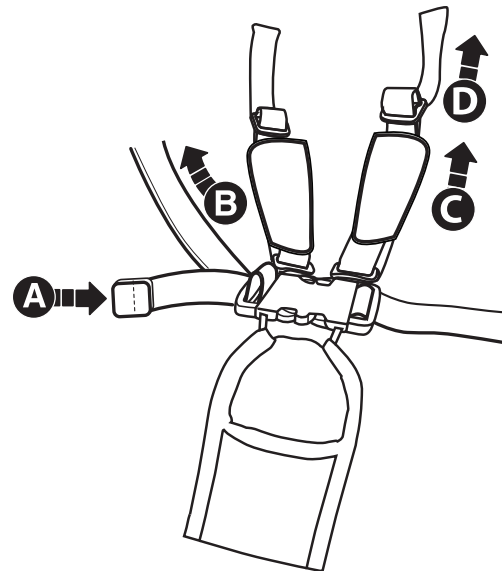

LOOSEN

3

To tighten the waist belts and shoulder straps (on some models):

- Feed the anchored end of a waist belt up through the buckle to form a loop **A**. Pull the free end of the waist belt **B**.
- Repeat this procedure to tighten the other waist belt.
- Feed the top end of the shoulder strap through the plastic stay to form a loop **C**. Pull the bottom end down to tighten the strap **D**.
- Repeat this procedure to tighten the other shoulder strap.

To loosen the waist belts and shoulder straps (on some models):

- Feed the free end of the waist belt up through the buckle to form a loop **A**. Enlarge the loop by pulling on the end of the loop toward the buckle. Pull the anchored end of the waist belt to shorten the free end of the waist belt **B**.
- Repeat this procedure to loosen the other waist belt.
- Feed the bottom end of the shoulder strap through the plastic stay to form a loop **C**. Pull the top end up to loosen the strap **D**.
- Repeat this procedure to loosen the other shoulder strap.

Please note: After adjusting the restraint system to fit your child, make sure you pull on it to be sure it is securely fastened.

Storage

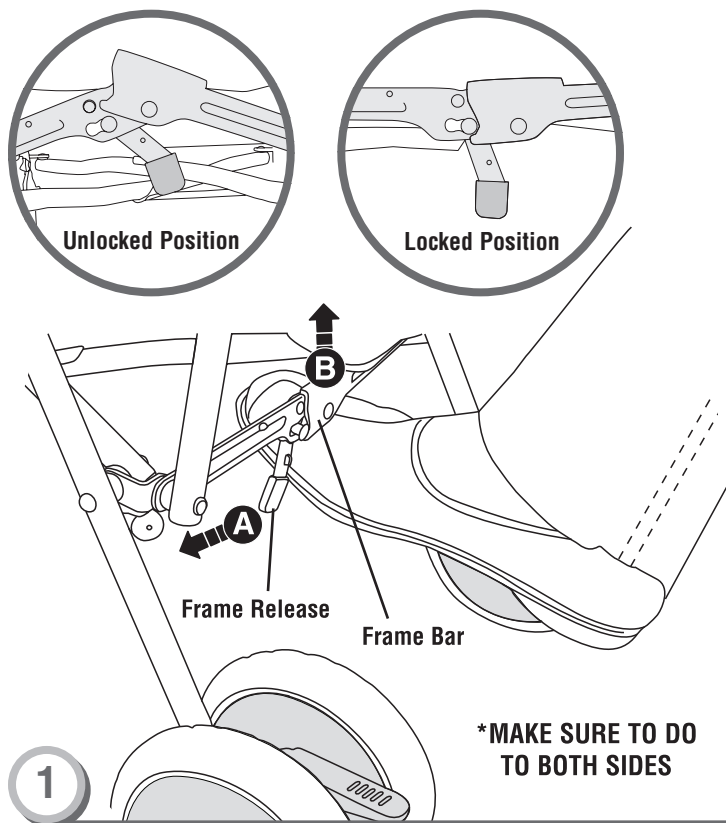

***MAKE SURE TO DO TO BOTH SIDES**

Hint: Make sure canopy is in the closed position before folding the stroller.

- With your foot, slide the frame release to the left **A**, then push up on the frame bar **B**.

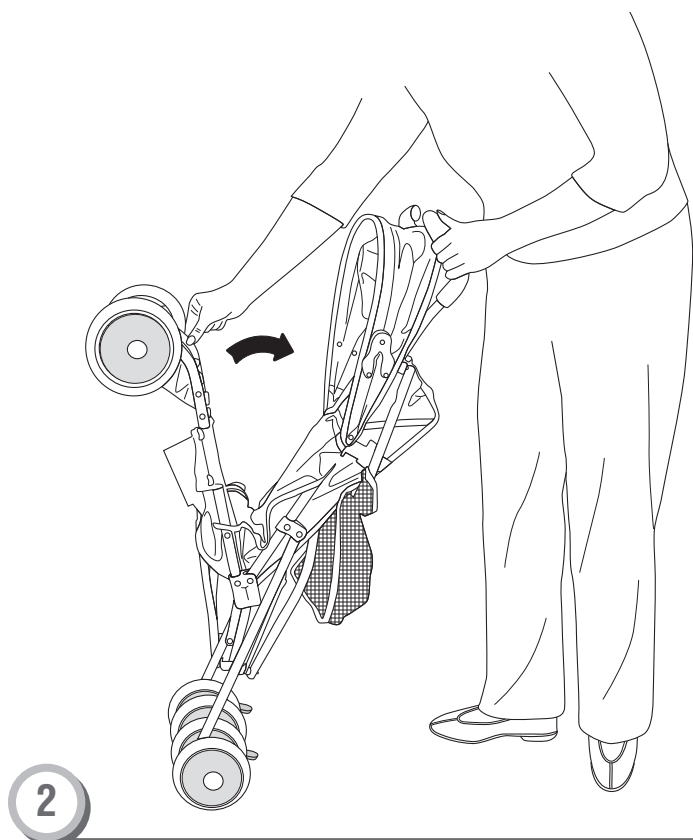

- Lift the front wheels toward the closed canopy.

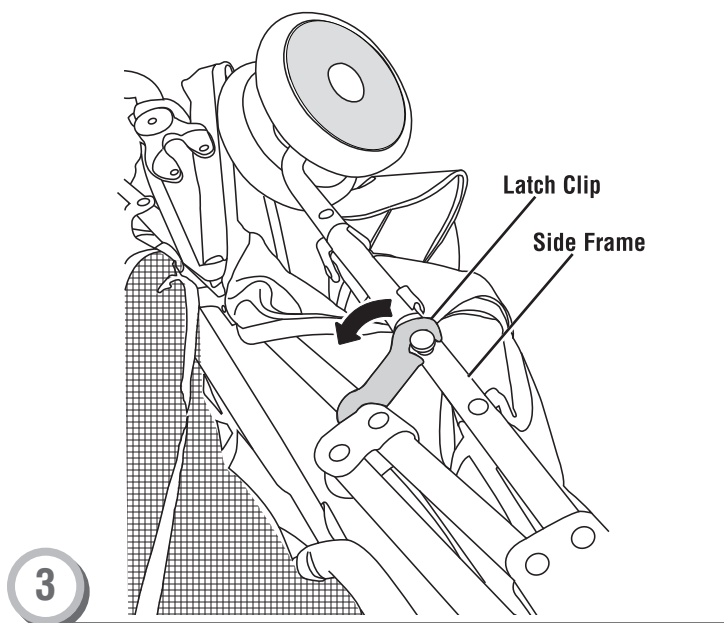

- Slide the latch clip onto the side frame to secure in the folded storage position.



Delta Children

114 West 26th Street
New York, NY 10001
(646) 435-8726

www.DeltaChildren.com