

DARWIN SEATS KAGUYU



OUTLET	TEAMWEAR & LIFESTYLE	TEAMWEAR & LIFESTYLE	e-SPORTS	PERFORMANCE	KARTING	KARTING	RACING	RACING	RACING
	CAPSULE COLLECTIONS	CLOTHING ACCESSORIES	SIM RACING CHAIRS	SEATS HARNESSES STEERING WHEELS	SHOES / GLOVES PROTECTIONS	SUITS UNDERWEAR	MECHANICS TECHNICAL	HARNESSES STEERING WHEELS	SEATS

HOMOLOGATION 8862-2009

SUPERCARBON TECHNOLOGY

ADV PRIME / ADV PRIME PAD

SHELL: CARBON FIBER
SIZE: L
HRS: YES
WEIGHT (GR): SHELL: 8300 / SEAT: 10500



ADV XT

SHELL: CARBON FIBER
SIZE: L
HRS: YES
WEIGHT (GR): SHELL: 7500 / SEAT: 10750



ADV ELITE

SHELL: CARBON FIBER
SIZE: L
HRS: YES
WEIGHT (GR): SHELL: 7810 / SEAT: 10300



ADV SCX / ADV SCX-H

SHELL: CARBON FIBER
SIZE: M/L
HRS: YES
WEIGHT (GR): SHELL **ADV SCX:** 8575 / SEAT: 10750
 SHELL **ADV SCX-H:** 8575 / SEAT: 10750



ADV SC

SHELL: CARBON FIBER
SIZE: M
HRS: YES
WEIGHT (GR): SHELL: 10485 / SEAT: 12900



ADV COMPETITION / ADV COMPETITION PAD

SHELL: CARBON FIBER
SIZE: M/L
HRS: YES
WEIGHT (GR): SHELL: 9000 / SEAT: 11200 (11000 PAD)



HOMOLOGATION 8855-2021

NEW 8855-2021 STANDARD

ADV XT

SHELL: FIBERGLASS
SIZE: L
HRS: YES
WEIGHT (GR): SHELL: 9700 / SEAT: 12000



MASTER

SHELL: FIBERGLASS
SIZE: L
HRS: YES
WEIGHT (GR): SHELL: 11250 / SEAT: 14000



MATRIX

SHELL: FIBERGLASS
SIZE: L
HRS: YES
WEIGHT (GR): SHELL: 12000 / SEAT: 14900



CARBON / CARBON-KEVLAR TECHNOLOGY

LEGEND

SHELL: CARBON-KEVLAR
SIZE: S
HRS: NO
WEIGHT (GR): SHELL: 5300 / SEAT: 6000



QRT-C

SHELL: CARBON FIBER
SIZE: M
HRS: NO
WEIGHT (GR): SHELL: 4300 / SEAT: 5500



GAMMA EVO CARBON

SHELL: CARBON FIBER
SIZE: M/L/XL
HRS: NO
WEIGHT (GR): SHELL **EVO / EVO L:** 4500 / SEAT: 5600
 SHELL **EVO XL:** 4800 / SEAT: 6100



HOMOLOGATION 8855-1999

CIRCUIT CARBON / CIRCUIT CARBON II

SHELL: CARBON FIBER
SIZE: M/L
HRS: YES
WEIGHT (GR): SHELL **CIRCUIT:** 6400 / SEAT: 7900
 SHELL **CIRCUIT II:** 6700 / SEAT: 8200



HOMOLOGATION 8855-1999

CARBON TECHNOLOGY

ULTRA CARBON

SHELL: CARBON FIBER
 SIZE: S
 HRS: NO
 WEIGHT (GR): SHELL / SEAT: 4500

FIBERGLASS TECHNOLOGY

ULTRA

SHELL: GLASS FIBER
 SIZE: S
 HRS: NO
 WEIGHT (GR): SHEL / SEAT: 6200

QRT TECHNOLOGY

QRT-R / QRT-R SKY

SHELL: QRT SIZE: M HRS: NO
 WEIGHT (GR): SHELL: QRT-R: 5900 / SEAT QRT-R: 7600
 SHELL QRT-R SKY: 5900 / SEAT QRT-R SKY: 8300

PRO 2000 QRT

SHELL: QRT SIZE: L HRS: NO
 WEIGHT (GR): SHELL: 6800 / SEAT: 8000

PRO ADV QRT

SHELL: QRT SIZE: M/L HRS: YES
 WEIGHT (GR): SHELL: 7800 / SEAT: 9300

CIRCUIT QRT / CIRCUIT II QRT

SHELL: QRT SIZE: L HRS: YES
 WEIGHT (GR): SHELL CIRCUIT: 7100 / SEAT CIRCUIT: 8600
 SHELL CIRCUIT II: 7200 / SEAT CIRCUIT II: 9600



008037ZNR



008037FNR



008012RNR



008012RNRSKY



008016RNR



008017RNR



008019RNR



008011RNR

QRT TECHNOLOGY

EVO QRT RANGE

SHELL: QRT TAGLIA: M/L/XL HRS: NO
 WEIGHT (GR): SHELL EVO L QRT: 6500 / SEAT EVO L QRT: 7700
 SHELL EVO XL QRT: 6700 / SEAT EVO XL QRT: 7900
 SHELL EVO QRT: 5000 / SEAT EVO QRT: 7300
 SHELL EVO SKY QRT: 5000 / SEAT EVO SKY QRT: 7300



008007RNR



008007RNRSKY



008013RNR



008015RNR

EVO QRT X RANGE

SHELL: QRT SIZE: M/L/XL HRS: NO
 WEIGHT (GR): SHELL EVO L QRT X: 6500
 SEAT EVO L QRT X: 7700
 SHELL EVO XL QRT X: 6700
 SEAT EVO XL QRT X: 7900
 SHELL EVO QRT X: 5000
 SEAT EVO QRT X: 7300



008007XNR



008013XNR



008015XNR

GRID-Q / GRID-Q SKY

SHELL: QRT SIZE: M HRS: NO
 WEIGHT (GR): SHELL GRID-Q: 6500 / SEAT GRID-Q: 7300
 SHELL GRID-Q SKY: 6500 / SEAT GRID-Q SKY: 7700



008009RNR



008009RNRSKY

REV QRT

SHELL: QRT SIZE: S/M HRS: NO
 WEIGHT (GR): SHELL: 6000 / SEAT: 7100



008014RNR

TUBULAR FRAME TECHNOLOGY

SPRINT RANGE

SHELL: TUBULAR SIZE: M/L HRS: NO
 WEIGHT (GR): SHELL SPRINT L: 10400
 SHELL SPRINT/SPRINT SKY: 7940
 SEAT SPRINT L: 11000
 SEAT SPRINT/SPRINT SKY: 9700



008235..



008234L..



008235NRSKY

HOMOLOGATION 8855-1999

*THE INDICATED WEIGHT IS CALCULATED ON THE AVERAGE VALUE OF THE ANALYZED SAMPLES, IT CAN UNDERGO VARIATIONS.

HOMOLOGATION: FIA 8862-2009
MATERIAL: CARBON FIBER **HRS:** YES
WEIGHT (GR): SHELL: 8300 / SEAT: 10500

MANUFACTURER: SPARCO
MODEL: ADV PRIME
HOM. NO: AS.095.21
FIA STANDARD: 8862-2009

€ 4.860,00
VAT not included

HIGHLIGHTS



New use of k-point fabric.



Full-length cushion with separate leg rest.



€ 263,00
VAT not included

004990ADV

The seat is approved in conjunction with the side mounting frames **004990ADV**.



● **008033ZNR**

- Developed in collaboration with M-sport.
- New Lining design.
- Self-extinguishing fabric lining.
- FIA approved energy absorbing padding.
- M12 lateral fastening with 290 mm spacing.

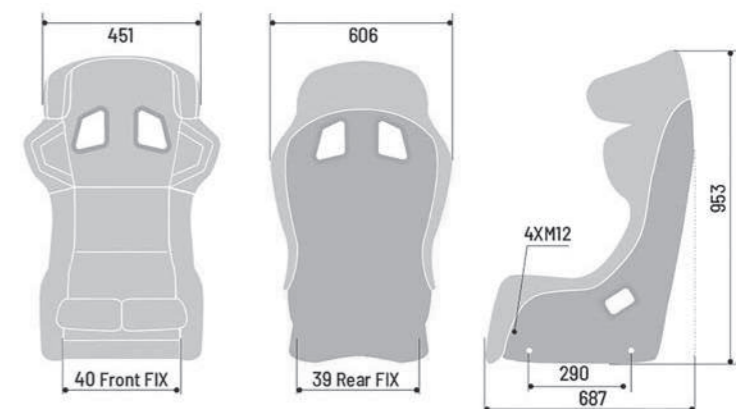

RACING SEATS

RACING HARNESSES STEERING WHEELS

RACING MECHANICS TECHNICAL

KARTING SUITS UNDERWEAR

KARTING SHOES / GLOVES PROTECTIONS

PERFORMANCE SEATS HARNESSES STEERING WHEELS

e-SPORTS SIM RACING CHAIRS

TEAMWEAR & LIFESTYLE CLOTHING ACCESSORIES

TEAMWEAR & LIFESTYLE CAPSULE COLLECTIONS

OUTLET

ADV PRIME PAD



HOMOLOGATION: FIA 8862-2009
MATERIAL: CARBON FIBER **HRS:** YES
WEIGHT (GR): SHELL: 8300 / SEAT: 10500

MANUFACTURER: SPARCO
MODEL: ADV PRIME
HOM. NO: AS.095.21
FIA STANDARD: 8862-2009

€ 4.900,00
VAT not included



HIGHLIGHTS



New use of k-point fabric.



Full-length cushion with separate leg rest.



€ 263,00
VAT not included

004990ADV

The seat is approved in conjunction with the side mounting frames **004990ADV**.



008033ZPNR

- New upholstery design with removable pad in double density foam.

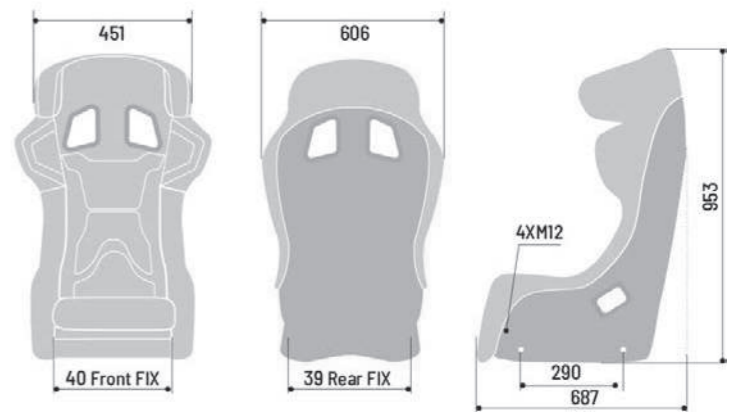

RACING SEATS
RACING HARNESSES STEERING WHEELS
RACING MECHANICS TECHNICAL
KARTING SUITS UNDERWEAR
KARTING SHOES / GLOVES PROTECTIONS
PERFORMANCE SEATS HARNESSES STEERING WHEELS
e-SPORTS SIM RACING CHAIRS
TEAMWEAR & LIFESTYLE CLOTHING ACCESSORIES
TEAMWEAR & LIFESTYLE CAPSULE COLLECTIONS
OUTLET

HOMOLOGATION: FIA 8862-2009
MATERIAL: CARBON FIBER **HRS:** YES
WEIGHT (GR): SHELL: 7500 / SEAT: 10750

MANUFACTURER: SPARCO
 MODEL: ADV XT
 HOM. NO: AS.064.17
 FIA STANDARD: 8862-2009

€ 5.682,00
 VAT not included

HIGHLIGHTS



Self-extinguishing fabric lining.



Split leg rest cushion.



The seat is approved in conjunction with the side mounting frames **0049605**.



008002ZNR

- FIA-approved energy absorbing padding.
- Attached using M12 lateral fastenings with 290 mm spacing.
- Non-slip fabric for shoulders and seat.

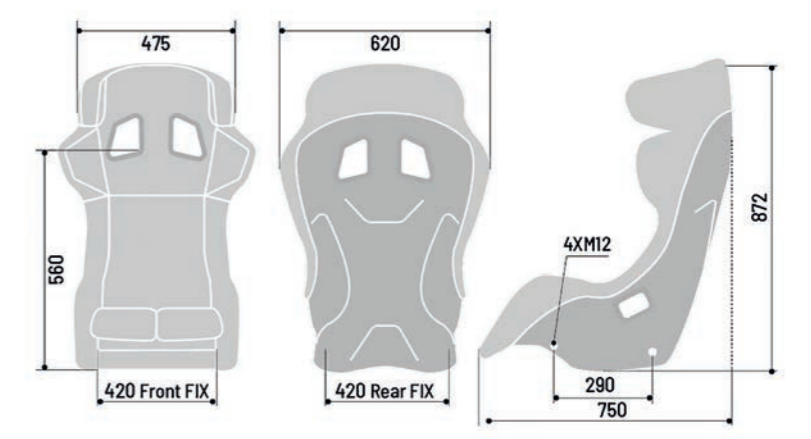

RACING SEATS
RACING HARNESSES STEERING WHEELS
RACING MECHANICS TECHNICAL
KARTING SUITS UNDERWEAR
KARTING SHOES / GLOVES PROTECTIONS
PERFORMANCE SEATS HARNESSES STEERING WHEELS
e-SPORTS SIM RACING CHAIRS
TEAMWEAR & LIFESTYLE CLOTHING ACCESSORIES
TEAMWEAR & LIFESTYLE CAPSULE COLLECTIONS
OUTLET

HOMOLOGATION: FIA 8862-2009
MATERIAL: CARBON FIBER **HRS:** YES
WEIGHT (GR): SHELL: 7810 / SEAT: 10300

MANUFACTURER: SPARCO
 MODEL: ADV ELITE
 HOM. NO: AS.037.14
 FIA STANDARD: 8862-2009

€ 5.297,00
 VAT not included

HIGHLIGHTS

- Self-extinguishing fabric lining.
- Improved habitability and comfort.



FIA-approved energy absorbing padding.



Non-slip fabric for shoulders and seat.



004988ADV

The seat is approved in conjunction with the side mounting frames 004988ADV.



00849ZNR

- Attached using M12 lateral fastenings with 290 mm spacing.

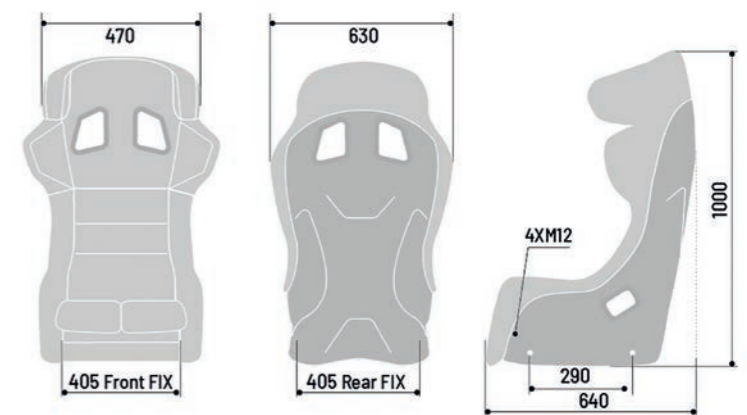

RACING SEATS

RACING HARNESSES STEERING WHEELS

RACING MECHANICS TECHNICAL

KARTING SUITS UNDERWEAR

KARTING SHOES / GLOVES PROTECTIONS

PERFORMANCE SEATS HARNESSES STEERING WHEELS

e-SPORTS SIM RACING CHAIRS

TEAMWEAR & LIFESTYLE CLOTHING ACCESSORIES

TEAMWEAR & LIFESTYLE CAPSULE COLLECTIONS

OUTLET

ADV SCX / SCX-H

HOMOLOGATION: FIA 8862-2009
MATERIAL: CARBON FIBER **HRS:** YES
WEIGHT (GR): SHELL: 8575 / SEAT: 10750



MANUFACTURER: SPARCO
 MODEL: ADV-SCX
 HOM. NO: AS.022.12
 FIA STANDARD: 8862-2009

€ 4.912,00
 VAT not included

HIGHLIGHTS



Non-slip fabric for shoulders and seat.



Split legrest cushion.



€ 298,00
 VAT not included

004985ADV (ADV SCX)
 004984ADV (ADV SCX-H)

The seat is approved in conjunction with the side mounting frames ADV SCX and ADV SCX-H.

- Self-extinguishing fabric lining.
- FIA-approved energy absorbing padding.
- Attached using M12 lateral fastenings with 290 mm spacing.



00804ZNR

ADV SCX-H



MANUFACTURER: SPARCO
 MODEL: ADV-SCX H
 HOM. NO: AS.016.11
 FIA STANDARD: 8862-2009

€ 5.008,00
 VAT not included

00805ZNR

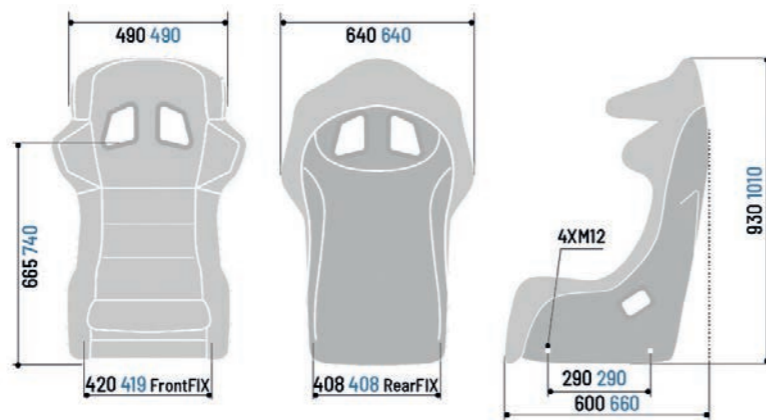

ADV SC

HOMOLOGATION: FIA 8862-2009
MATERIAL: CARBON FIBER **HRS:** YES
WEIGHT (GR): SHELL: 10485 / SEAT: 12900



MANUFACTURER: SPARCO
 MODEL: ADV-SC 19
 HOM. NO: AS.070.18
 FIA STANDARD: 8862-2009

€ 3.366,00
 VAT not included

HIGHLIGHTS



Self-extinguishing fabric lining.



Non-slip fabric for shoulders and seat.



€ 394,00
 VAT not included

004982ADV

The seat is approved in conjunction with the side mounting frames 004982ADV.

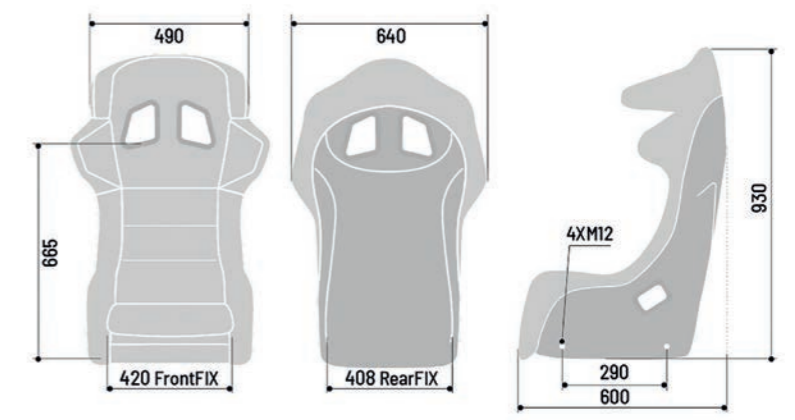

008020ZNR

- FIA-approved energy absorbing padding.
- Attached using M12 lateral fastenings with 290 mm spacing.

ADV COMPETITION



HOMOLOGATION: FIA 8862-2009 MATERIAL: CARBON FIBER
HRS: YES WEIGHT (GR): SHELL: 9000 / SEAT: 11200

MANUFACTURER: SPARCO
MODEL: ADV COMPETITION
HOM. NO: AS.099.22
FIA STANDARD: 8862-2009

€ 3.800,00
VAT not included

HIGHLIGHTS



New use of k-point fabric.



Full-length cushion with separate leg rest.



€ 263,00
VAT not included

The seat is approved in conjunction with the side mounting frames **004990ADV**.



■ 008034ZNR

- Shaped backrest to wrap around the driver.
- Efficient construction technology.

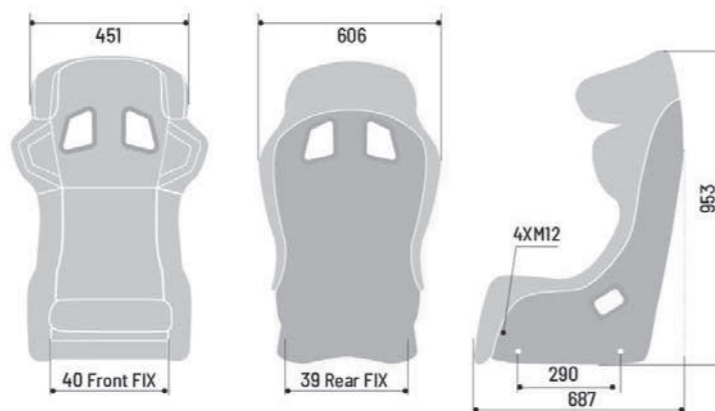

ADV COMPETITION

PAD



HOMOLOGATION: FIA 8862-2009 MATERIAL: CARBON FIBER
HRS: YES WEIGHT (GR): SHELL: 9000 / SEAT: 11000

MANUFACTURER: SPARCO
MODEL: ADV COMPETITION
HOM. NO: AS.099.22
FIA STANDARD: 8862-2009

€ 3.900,00
VAT not included

HIGHLIGHTS



Shaped backrest to better fit the driver.



Backrest with additional reinforcement in the lumbar area.



€ 263,00
VAT not included

The seat is approved in conjunction with the side mounting frames **004990ADV**.



■ 008034ZPNR

- Ergonomics designed for professional drivers.
- Shaped backrest to wrap around the driver.
- Backrest with additional reinforcement in the lumbar area.
- Efficient construction technology.
- New upholstery design with removable pad in double density foam.

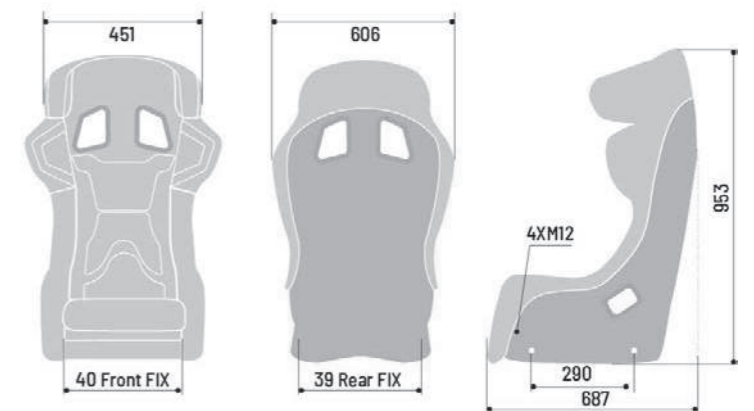

HOMOLOGATION: FIA 8855-2021 **MATERIAL:** FIBERGLASS
HRS: YES **WEIGHT (GR):** SHELL: 9700 / SEAT: 12000

MANUFACTURER: SPARCO
 MODEL: ADV XT
 HOM. NO: CS.008.21
 FIA STANDARD: 8855-2021

€ 1.100,00
 VAT not included

HIGHLIGHTS



FIA-approved energy absorbing padding.



Integrated racing net guides.

€ 250,00
 VAT not included

004932H
004932L

The seat is approved with two different side mounting frames height (in conjunction with mounting frames **004932H** e **004932L**).



● **008032FNR**

- Self-extinguishing fabric lining.
- Suitable for drivers between 1.65 - 1.80 m in height.
- Split leg rest cushion.
- Attached using M12 lateral fastenings with 290 mm spacing.

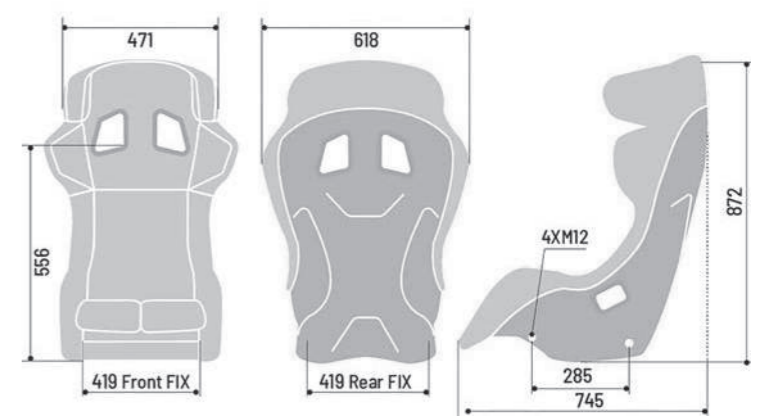

RACING SEATS

RACING HARNESSES STEERING WHEELS

RACING MECHANICS TECHNICAL

KARTING SUITS UNDERWEAR

KARTING SHOES / GLOVES PROTECTIONS

PERFORMANCE SEATS HARNESSES STEERING WHEELS

e-SPORTS SIM RACING CHAIRS

TEAMWEAR & LIFESTYLE CLOTHING ACCESSORIES

TEAMWEAR & LIFESTYLE CAPSULE COLLECTIONS

OUTLET

HOMOLOGATION: FIA 8855-2021 **MATERIAL:** FIBERGLASS
HRS: YES **WEIGHT (GR):** SHELL: 11250 / SEAT: 14000

MANUFACTURER: SPARCO
 MODEL: MASTER
 HOM. NO: CS.004.21
 FIA STANDARD: 8855-2021

€ 1.200,00
 VAT not included



HIGHLIGHTS



Insertion of internal memory foam pads.



Integrated racing net guides.



€ 263,00
 VAT not included

The seat is approved in conjunction with mounting frames **004919**.

Specific brackets approved for: **Renault Clio RALLY3, RALLY4, RALLY5, Ford Fiesta RALLY3.**



008030FNR

- New seat compliant with the more stringent 8855-2021 approval.
- Suitable for drivers between 1.75 - 1.95 m in height.
- Shock absorbing foam on the head.
- Non-slip fabric for shoulders and seat.

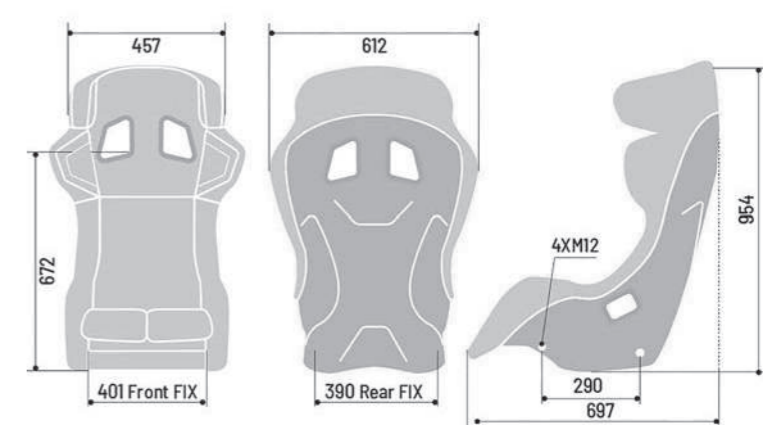

RACING SEATS
RACING HARNESSES STEERING WHEELS
RACING MECHANICS TECHNICAL
KARTING SUITS UNDERWEAR
KARTING SHOES / GLOVES PROTECTIONS
PERFORMANCE SEATS HARNESSES STEERING WHEELS
e-SPORTS SIM RACING CHAIRS
TEAMWEAR & LIFESTYLE CLOTHING ACCESSORIES
TEAMWEAR & LIFESTYLE CAPSULE COLLECTIONS
OUTLET

Official 2024 Peugeot Rally 4 seat



HIGHLIGHTS



Developed according to the new technical regulations 8855-2021.



Special reinforcing foil with honeycomb matrix.



€ 263,00
 VAT not included

The seat is approved in conjunction with the side mounting frames **004926**.

Specific brackets approved for: **Peugeot 208 RALLY4**.



008036SNR

- Designed for greater ergonomics using sae manikin.
- New efficient construction technology.

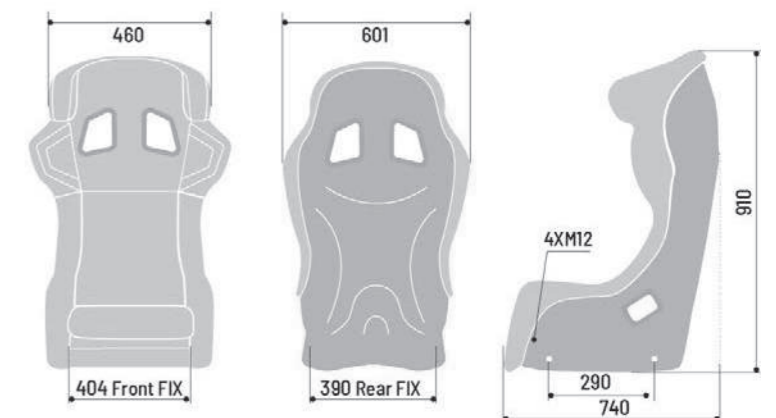

LEGEND

HOMOLOGATION: FIA 8855-1999
MATERIAL: CARBON-KEVLAR PRE-PREG
HRS: NO WEIGHT (GR): SHELL: 5300 / SEAT: 6000



MANUFACTURER: SPARCO
MODEL: LEGEND
HOM. NO: CS.459.20
FIA STANDARD: 8855-1999

€ 1.625,00
VAT not included

HIGHLIGHTS



VEP fabric with original checkered lining.



Pre-preg carbon-kevlar frame.



Lower fasteners 317x345 (M8) (does not mount on guide **00943..**).

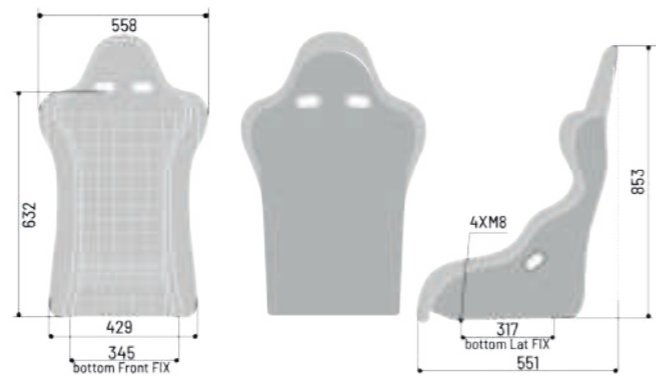

QRT-C

HOMOLOGATION: FIA 8855-1999
MATERIAL: CARBON FIBER **HRS: NO**
WEIGHT (GR): SHELL: 4300 / SEAT: 5500



MANUFACTURER: SPARCO
MODEL: QRT-C 20
HOM. NO: CS.437.19
FIA STANDARD: 8855-1999

€ 1.507,00
VAT not included

HIGHLIGHTS



High structural strength.



Non-slip fabric for shoulders and seat.



Attached using M8 lateral fastenings with 290 mm spacing.



008025ZNR

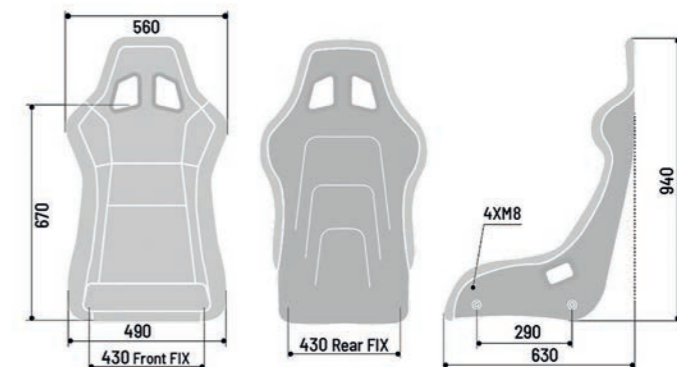

EVO CARBON

HOMOLOGATION: FIA 8855-1999 **MATERIAL:** CARBON FIBER
HRS: NO **WEIGHT (GR):** SHELL 4500 / SEAT 5600

€ 1.550,00
VAT not included

HIGHLIGHTS



Non-slip fabric for shoulders and seat.



Super light shell in carbon fiber.



Attached using M8 lateral fastenings with 290 mm spacing.



MANUFACTURER: SPARCO
MODEL: EVO CARBON
HOM. NO: CS.485.22
FIA STANDARD: 8855-1999



● 008007ZNR

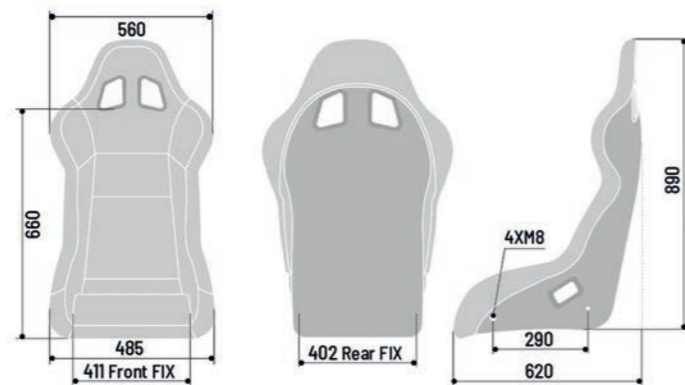

EVO CARBON

L/XL

HOMOLOGATION: FIA 8855-1999 **MATERIAL:** CARBON FIBER **HRS:** NO
WEIGHT (GR): EVO L SHELL: 4500 / SEATS: 5600 - EVO XL SHELL: 4800 / SEATS: 6100

HIGHLIGHTS



Non-slip fabric for shoulders and seat.



Super light shell in carbon fiber.



Attached using M8 lateral fastenings with 290 mm spacing.

EVO L CARBON



MANUFACTURER: SPARCO
MODEL: EVO L CARBON
HOM. NO: CS.486.22
FIA STANDARD: 8855-1999

€ 1.600,00
VAT not included



● 008013ZNR

EVO XL CARBON



MANUFACTURER: SPARCO
MODEL: EVO XL CARBON
HOM. NO: CS.487.22
FIA STANDARD: 8855-1999

€ 1.650,00
VAT not included



● 008015ZNR

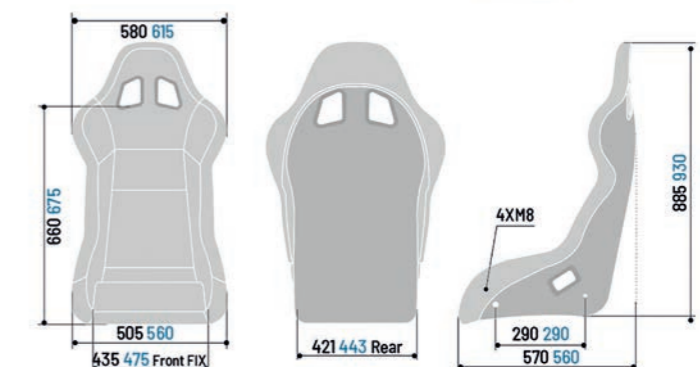

CIRCUIT CARBON

HOMOLOGATION: FIA 8855-1999 **MATERIAL:** CARBON FIBER
SIZE: M **HRS:** YES **WEIGHT (GR):** SHELL: 6400 / SEAT: 7900

€ 1.400,00
VAT not included

HIGHLIGHTS



Non-slip fabric for shoulder and seat restraint.



Super light shell in carbon fiber.



Divisible leg rest and seat cushion.



FIA APPROVED
MANUFACTURER: SPARCO
MODEL: CIRCUIT I CARBON
HOM. NO: CS.494.22
FIA STANDARD: 8855-1999



008019ZNR

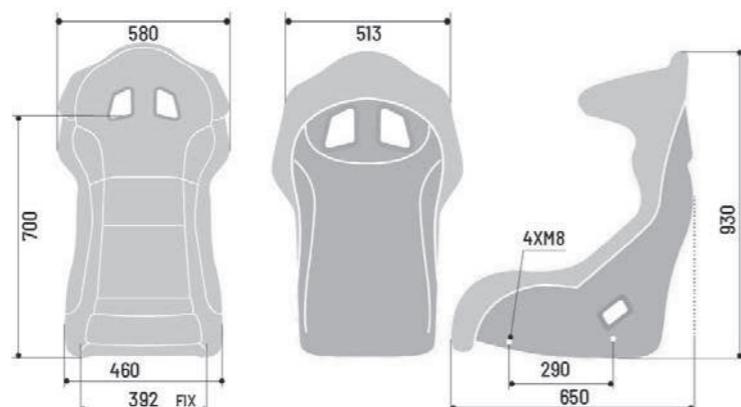

CIRCUIT II CARBON

HOMOLOGATION: FIA 8855-1999 **MATERIAL:** CARBON FIBER
SIZE: L **HRS:** YES **WEIGHT (GR):** SHELL: 6700 / SEAT: 8200

€ 1.500,00
VAT not included

HIGHLIGHTS



Non-slip fabric for shoulder and seat restraint.



Super light shell in carbon fiber.



Divisible leg rest and seat cushion.



FIA APPROVED
MANUFACTURER: SPARCO
MODEL: CIRCUIT II CARBON
HOM. NO: CS.495.22
FIA STANDARD: 8855-1999



008011ZNR

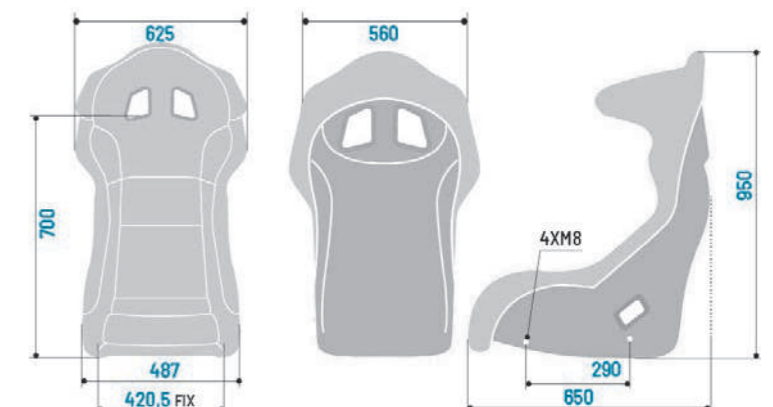

HOMOLOGATION: FIA 8855-1999 **MATERIAL:** CARBON FIBER
SIZE: S **HRS:** NO **WEIGHT (GR):** SHELL / SEAT: 4500

MANUFACTURER: SPARCO
 MODEL: ULTRA CARBON
 HOM. NO: CS.500.22
 FIA STANDARD: 8855-1999

€ 1.250,00
 VAT not included



HIGHLIGHTS



Ultralight seat.



Laminated with double shell in Carbon Fiber.



Ergonomics designed for use without padding.



■ Suitable for narrow cockpits.



008037ZR



SPACERS KIT OF 4. 20MM
 € 5,00
 VAT not included

04503

■ Nylon spacer bushings

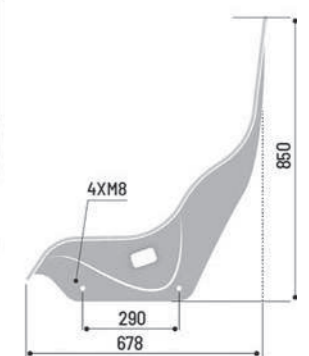



MANUFACTURER: SPARCO
MODEL: ULTRA
HOM. NO: CS.499.22
FIA STANDARD: 8855-1999

HOMOLOGATION: FIA 8855-1999 MATERIAL: FIBERGLASS
SIZE: S HRS: NO WEIGHT (GR): SHELL / SEAT: 6200

€ 950,00
VAT not included

HIGHLIGHTS



Ultralight seat.



Laminated with double shell in Glass Fiber.



Ergonomics designed for use without padding.



- Suitable for narrow cockpits.



008037FNR



SPACERS KIT OF 4. 20MM
€ 5,00
VAT not included

04503

- Nylon spacer bushings

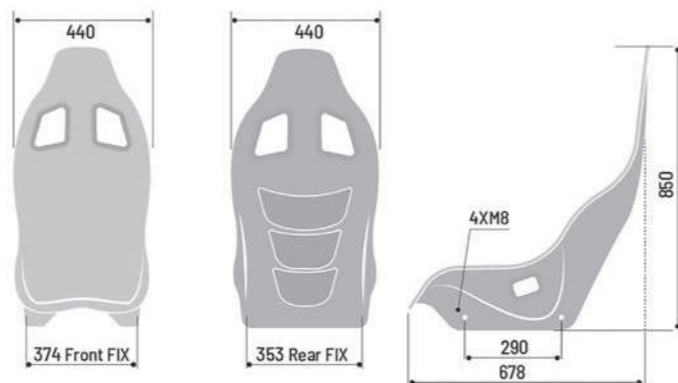

NEW ULTRA PADDING FULL KIT ALCANTARA®



Padding kit consisting of:

- Headrest
- Scapular
- Lumbar
- Cushion

Alcantara-covered pads.
Possibility of repositioning the pads on the shell by means of Velcro.
Foam padding made of anti-vibration material.

010411PAD1

€ 230,00
VAT not included

NEW ULTRA HEAD+BOTTOM PADDING ALCANTARA®



Padding kit for cushion and headrest covered in Alcantara.
Possibility of repositioning the pads on the shell via Velcro.
Foam padding made of anti-vibration material.

010411PAD3

€ 115,00
VAT not included

NEW ULTRA PADDING FULL KIT OPT



Padding kit consisting of:

- Headrest
- Scapular
- Lumbar
- Cushion

Waterproof coated pads.
Possibility of repositioning the pads on the shell by means of Velcro.
Foam padding made of anti-vibration material.

010411PAD2

€ 150,00
VAT not included

NEW ULTRA HEAD+BOTTOM PADDING OPT



Padding kit for cushion and headrest covered in waterproof material.
Possibility of repositioning the pads on the shell via Velcro.
Foam padding made of anti-vibration material.

010411PAD4

€ 75,00
VAT not included

RACING

RACING

RACING

KARTING

KARTING

KARTING

PERFORMANCE

e-SPORTS

TEAMWEAR & LIFESTYLE

TEAMWEAR & LIFESTYLE

OUTLET

SEATS

SEATS

HARNESSES

STEERING WHEELS

MECHANICS

TECHNICAL

SUITS

UNDERWEAR

SHOES / GLOVES

PROTECTIONS

SEATS

HARNESSES

STEERING WHEELS

SIM RACING

CHAIRS

CLOTHING

ACCESSORIES

CAPSULE

COLLECTIONS

QRT-R

HOMOLOGATION: FIA 8855-1999 **MATERIAL:** QRT
HRS: NO WEIGHT (GR): SHELL: 5900 / SEAT: 7600



MANUFACTURER: SPARCO
MODEL: QRT-R
HOM. NO: CS.397.18
FIA STANDARD: 8855-1999

€ 647,00
VAT not included

HIGHLIGHTS



Non-slip fabric for shoulders and seat.



Integrated lumbar support.



Attached using M8 lateral fastenings with 290 mm spacing.



● 008012RNR

QRT-R SKY



MANUFACTURER: SPARCO
MODEL: QRT-R
HOM. NO: CS.397.18
FIA STANDARD: 8855-1999

€ 690,00
VAT not included



- Attached using M8 lateral fastenings with 290 mm spacing.

● 008012RNRSKY

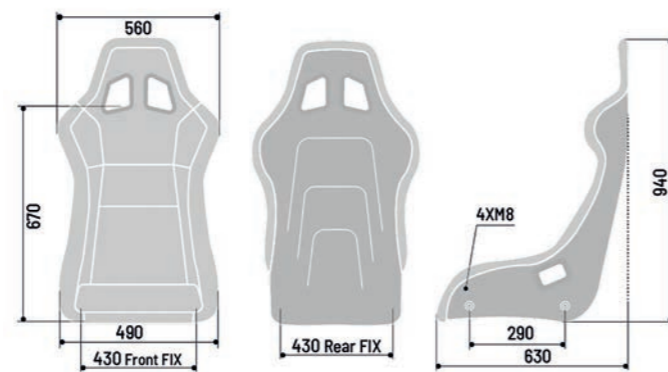

PRO 2000 QRT

HOMOLOGATION: FIA 8855-1999 **MATERIAL:** QRT
HRS: NO WEIGHT (GR): SHELL: 6800 / SEAT: 8000



MANUFACTURER: SPARCO
MODEL: PRO 2000 QRT
HOM. NO: CS.424.19
FIA STANDARD: 8855-1999

€ 547,00
VAT not included

HIGHLIGHTS



Non-slip fabric for shoulder and seat restraint.



Lateral kidney supports.



Divisible leg rest and seat cushion.



● 008016RNR

- Lower attached directly on M8 271x345 base.
- Attached using M8 lateral fastenings with 290 mm spacing.

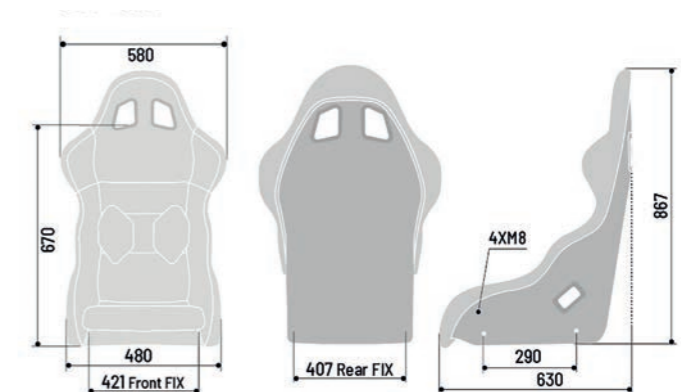

RACING SEATS
RACING HARNESSES STEERING WHEELS
RACING MECHANICS TECHNICAL
KARTING SUITS UNDERWEAR
KARTING SHOES / GLOVES PROTECTIONS
PERFORMANCE SEATS HARNESSES STEERING WHEELS
e-SPORTS SIM RACING CHAIRS
TEAMWEAR & LIFESTYLE CLOTHING ACCESSORIES
TEAMWEAR & LIFESTYLE CAPSULE COLLECTIONS
OUTLET

PRO ADV QRT

HOMOLOGATION: FIA 8855-1999 **MATERIAL:** QRT
HRS: YES **WEIGHT (GR):** SHELL: 7800 / SEAT: 9300



MANUFACTURER: SPARCO
MODEL: PRO ADV QRT
HOM. NO: CS.434.19
FIA STANDARD: 8855-1999

€ 615,00
VAT not included

HIGHLIGHTS



Non-slip fabric for shoulder and seat restraint.



Divisible leg rest and seat cushion.



Attached using M8 lateral fastenings.



008017RNR

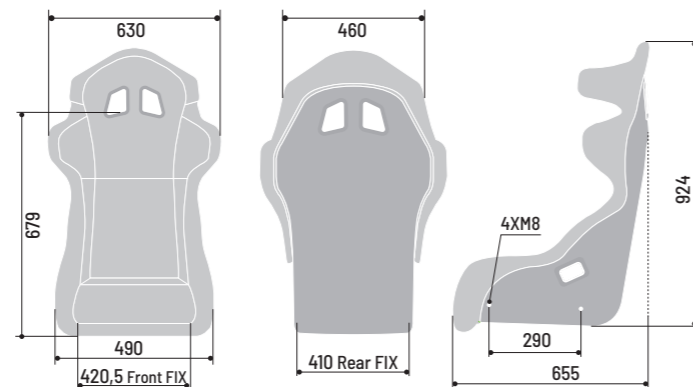

CIRCUIT QRT

HOMOLOGATION: FIA 8855-1999 **MATERIAL:** QRT **HRS:** YES
WEIGHT (GR): SHELL **CIRCUIT QRT:** 7100 / SEAT **CIRCUIT QRT:** 8600
SHELL **CIRCUIT II QRT:** 8600 / SEAT **CIRCUIT II QRT:** 9600



MANUFACTURER: SPARCO
MODEL: CIRCUIT QRT 20
HOM. NO: CS.431.19
FIA STANDARD: 8855-1999

€ 529,00
VAT not included

HIGHLIGHTS



Head Restraint System integrated.



Non-slip fabric for shoulder and seat restraint.



Divisible leg rest and seat cushion.



008019RNR

CIRCUIT II QRT



€ 559,00
VAT not included

MANUFACTURER: SPARCO
MODEL: CIRCUIT II QRT
HOM. NO: CS.408.18
FIA STANDARD: 8855-1999



008011RNR

Attached using M8 lateral fastenings with 290 mm spacing.

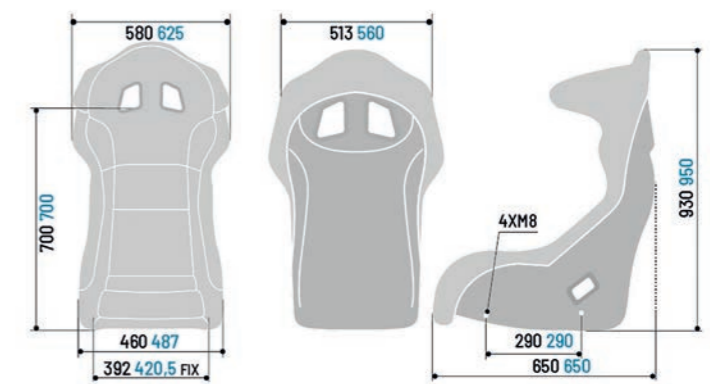

EVO QRT

HOMOLOGATION: FIA 8855-1999 **MATERIAL:** QRT
HRS: NO **WEIGHT (GR):** SHELL: 5000 / SEAT: 7300



MANUFACTURER: SPARCO
MODEL: EVO QRT
HOM. NO: CS.373.17
FIA STANDARD: 8855-1999

€ 540,00
VAT not included

HIGHLIGHTS



New backrest with integrated lumbar cushions.



Divisible leg rest and seat cushion.



Attached using MB lateral fastenings with 290 mm spacing.



008007RNR

EVO SKY QRT

€ 583,00
VAT not included

■ Sky upholstery.



008007RNRSKY

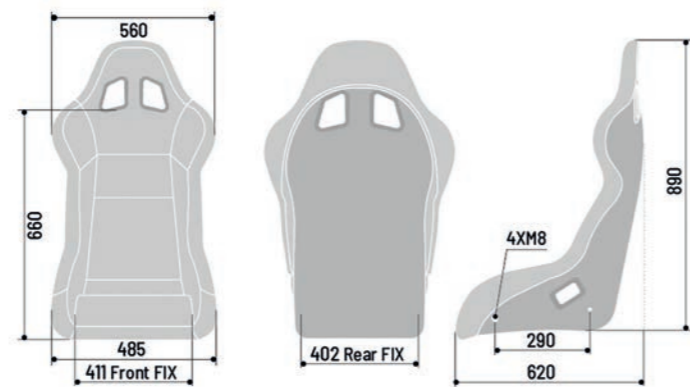

EVO QRT L/XL

HOMOLOGATION: FIA 8855-1999 **MATERIAL:** QRT **HRS:** NO
WEIGHT (GR): SHELL **EVO L QRT:** 6500 / SEAT **EVO L QRT:** 7700
SHELL **EVO XL QRT:** 6700 / SEAT **EVO XL QRT:** 7900



MANUFACTURER: SPARCO
MODEL: EVO L QRT
HOM. NO: CS.432.19
FIA STANDARD: 8855-1999

EVO L QRT

€ 583,00
VAT not included

HIGHLIGHTS



New backrest with integrated lumbar cushions.



Divisible leg rest and seat cushion.



Attached using MB lateral fastenings with 290 mm spacing.



008013RNR

EVO XL QRT



€ 626,00
VAT not included

MANUFACTURER: SPARCO
MODEL: EVO XL QRT
HOM. NO: CS.433.19
FIA STANDARD: 8855-1999



008015RNR

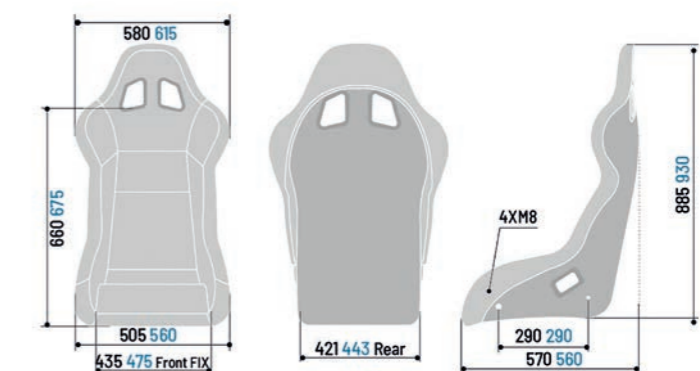

EVO QRT X

WATER-REPELLENT

HOMOLOGATION: FIA 8855-1999 MATERIAL: QRT HRS: NO
WEIGHT (GR): SHELL EVO QRT X: 5000 / SEAT EVO QRT X: 7300



MANUFACTURER: SPARCO
MODEL: EVO QRT
HOM. NO: CS.373.17
FIA STANDARD: 8855-1999

€582,00
VAT not included

HIGHLIGHTS



Waterproof fabric specific for off-road use.



Divisible leg rest and seat cushion.



Attached using M8 lateral fastenings with 290 mm spacing.



008007XNR

OFFROAD CUSHION P. 175



01033NR

01034XNR

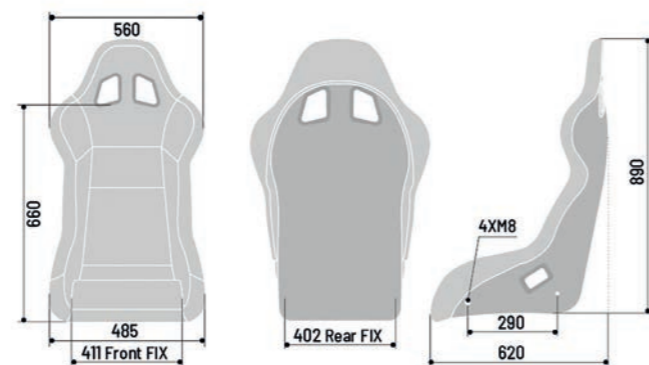

EVO QRT X L/XL

WATER-REPELLENT

HOMOLOGATION: FIA 8855-1999 MATERIAL: QRT HRS: NO
WEIGHT (GR): SHELL EVO L QRT X: 6500 / SEAT EVO XL QRT X: 7700
SHELL EVO XL QRT X: 6700 / SEAT EVO XL QRT X: 7900



MANUFACTURER: SPARCO
MODEL: EVO L QRT
HOM. NO: CS.432.19
FIA STANDARD: 8855-1999

EVO L QRT X

€ 626,00
VAT not included

HIGHLIGHTS



Waterproof fabric specific for off-road use.



Divisible leg rest and seat cushion.



Attached using M8 lateral fastenings with 290 mm spacing.



008013XNR

EVO XL QRT X



€ 662,00
VAT not included

MANUFACTURER: SPARCO
MODEL: EVO XL QRT
HOM. NO: CS.433.19
FIA STANDARD: 8855-1999



008015XNR

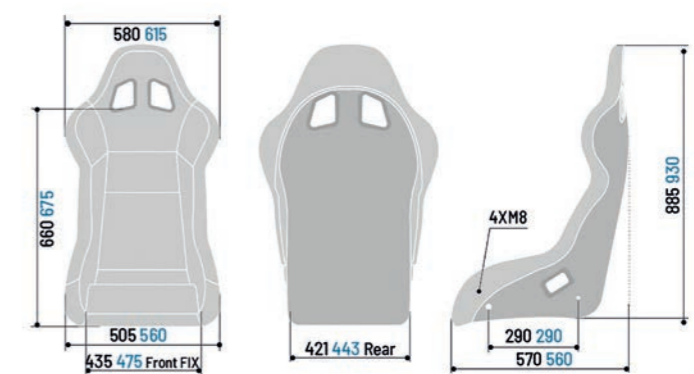

GRID-Q QRT

HOMOLOGATION: FIA 8855-1999 MATERIAL: QRT
HRS: NO WEIGHT (GR): SHELL 6500 / SEAT 7300



MANUFACTURER: SPARCO
MODEL: GRID Q
HOM. NO: CS.407.18
FIA STANDARD: 8855-1999

€ 399,00
VAT not included



HIGHLIGHTS



Non-slip fabric for shoulder and seat restraint.



Customizable padded pads.



Divisible leg rest and seat cushion.

008009RNR

GRID-Q SKY QRT

€ 440,00
VAT not included



008009RNRSKY

- Attached using M8 Lateral fastenings with 290 mm spacing.

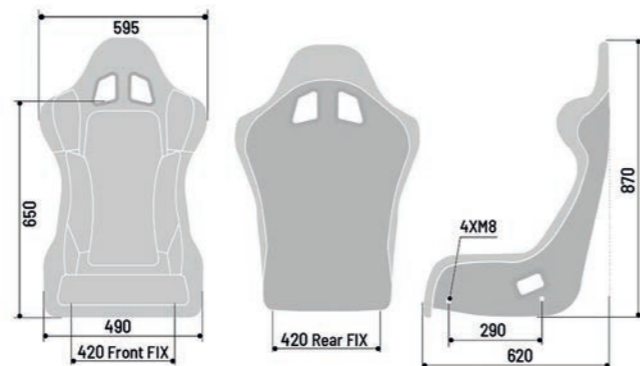

REV QRT

HOMOLOGATION: FIA 8855-1999 MATERIAL: QRT
HRS: NO WEIGHT (GR): SHELL 6000 / SEAT 7100



MANUFACTURER: SPARCO
MODEL: REV QRT
HOM. NO: CS.423.19
FIA STANDARD: 8855-1999

€ 385,00
VAT not included

HIGHLIGHTS



Non-slip fabric for shoulder and seat restraint.



New backrest with integrated lumbar cushions.



Attached using M8 lateral fastenings with 290 mm spacing.



008014RNR

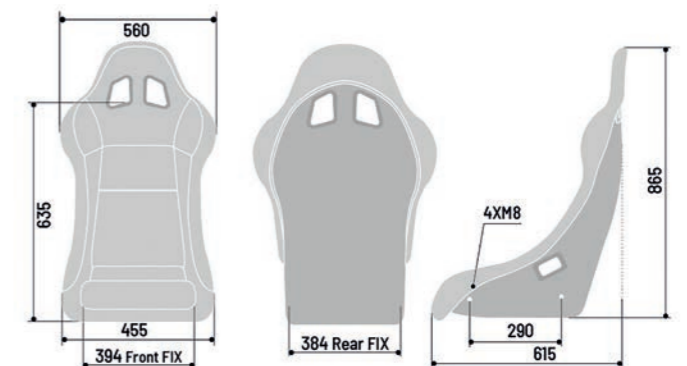

RACING SEATS
RACING HARNESSES STEERING WHEELS
RACING MECHANICS TECHNICAL
KARTING SUITS UNDERWEAR
KARTING SHOES / GLOVES PROTECTIONS
PERFORMANCE SEATS HARNESSES STEERING WHEELS
e-SPORTS SIM RACING CHAIRS
TEAMWEAR & LIFESTYLE CLOTHING ACCESSORIES
TEAMWEAR & LIFESTYLE CAPSULE COLLECTIONS
OUTLET

SPRINT/SPRINT L

HOMOLOGATION: FIA 8855-1999 **MATERIAL:** TUBULAR FRAME
HRS: NO WEIGHT (GR): SHELL SPRINT: 7940 / **SEAT SPRINT:** 9700
SHELL SPRINT L: 10400 / **SEAT SPRINT L:** 11000



MANUFACTURER: SPARCO
MODEL: SPRINT
HOM. NO: CS.332.15
FIA STANDARD: 8855-1999

€ 230,00
VAT not included

HIGHLIGHTS



Non-slip fabric for shoulder and seat restraint.



Tubular frame with elastic backrest and seat structure.



Lower attached directly on M8 271x345 base. Attached using M8 lateral fastenings with 290 mm spacing.

- 008235RS
- 008235AZ
- 008235NR

SPRINT L



MANUFACTURER: SPARCO
MODEL: SPRINT L
HOM. NO: CS.314.14
FIA STANDARD: 8855-1999

€265,00
VAT not included



- 008234LRS
- 008234LAZ
- 008234LNR

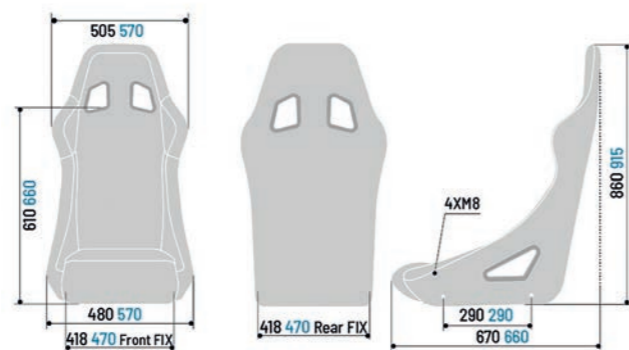

SPRINT SKY

HOMOLOGATION: FIA 8855-1999 **MATERIAL:** TUBULAR FRAME
HRS: NO WEIGHT (GR): SHELL SPRINT SKY: 7940
SEAT SPRINT SKY: 9700



MANUFACTURER: SPARCO
MODEL: SPRINT
HOM. NO: CS.332.15
FIA STANDARD: 8855-1999

€ 293,00
VAT not included

HIGHLIGHTS



Non-slip fabric for shoulder and seat restraint.



Sky upholstery.



Lower attached directly on M8 271x345 base. Attached using M8 lateral fastenings with 290 mm spacing.

- 008235NRSKY

- Elastic backrest and seat structure.
- Lower attached directly on M8 271x345 base.

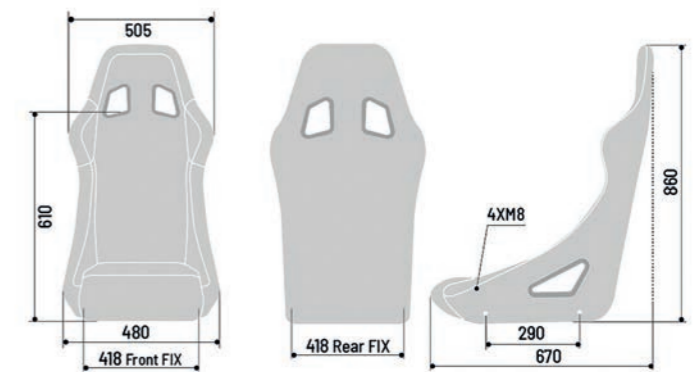

ACCESSORIES

SIDE SEAT

FIA-APPROVED MOUNTING FRAMES FOR SEATS WITH SIDE MOUNTING

€ 146,00
VAT not included



004903

Longitudinal distance between holes 290 mm. Max length 415 mm. Simple mounting in the car with more than 25 positions. 6 mm anodized aluminium.

€ 111,00
VAT not included

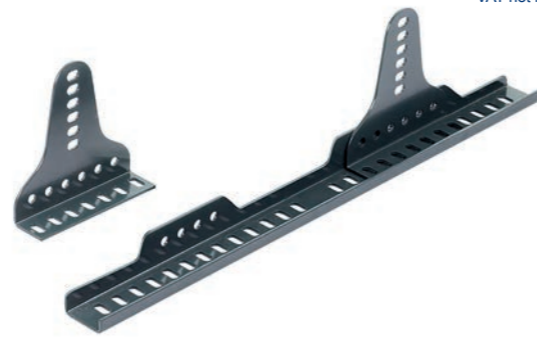

00492LAT

Dismountable mounting frame made of Steel. Maximum height and length adjustability (22 eyelets on the base element). New L shape of the lateral element to allow a double lockage with the base element.

€ 56,00
VAT not included



004915

290 mm spacing. High resistance steel, 3 mm thick. 500 mm length.

€ 86,00
VAT not included



004902

Longitudinal distance between holes 290 mm. Max length 400 mm. Simple mounting in the car with more than 25 positions. 3 mm black powder coated.

€ 54,00
VAT not included



004901NR

(L max 360 mm) Longitudinal wheelbase 290 mm. 3 mm thick steel.

SUBFRAMES FOR BOTTOM MOUNTING

FOR THE COMPLETE APPLICATION LIST SEE THE PRICE LIST.



DRIVER DRINK

€ 107,00
VAT not included



01045NR

Drink bag. Insulates from outside heat and keeps drinks at a constant temperature. Holds 1.5 litres, inner bottle and spout also available as spare parts. Four braces for attachment to the seat.

OFF ROAD CUSHION LOW - FIA COMPLIANT



Memory foam cushion.
01033NR

€ 79,00
VAT not included

Water repellent version.
01033XNR

€ 95,00
VAT not included

High density foam water repellent version.
01035XNR

€ 99,00
VAT not included

OFF ROAD CUSHION HIGH - NOT FIA COMPLIANT



Water repellent memory foam cushion high.
01034XNR

€ 105,00
VAT not included

High density foam water repellent version.
01036XNR

€ 109,00
VAT not included

OPTIONAL PADDING

€ 34,00
VAT not included



04108009PAD

Pair of side cushions suitable for FIA 8855-1999 seats.

€ 44,00
VAT not included



01011

Leg support cushion.

€ 32,00
VAT not included



● **01022NR**
● **01022AZ**
● **01022RS**

Pair of lumbar side backrests.

€ 32,00
VAT not included



01023

Universal lumbar backrest.

CUSHION FULL KIT (BACK + BOTTOM)

€ 101,00
VAT not included



CODE	SEAT
01048KIT8007NR	EVO QRT
01048KIT8007SKY	EVO QRT SKY
01048KIT8013NR	EVO L QRT
01048KIT8015NR	EVO XL QRT
01048KIT8014NR	REV QRT
01048KIT8012NR	QRT R
01048KIT8012SKY	QRT-R SKY
01048KIT8025NR	QRT-C

€ 101,00
VAT not included



CODE	SEAT
01048KIT8019NR	CIRCUIT
01048KIT8011NR	CIRCUIT II
01048KIT8017NR	PRO ADV QRT
01048KIT8016NR	PRO 2000 QRT
01048KIT8018NR	PILOT QRT
01048KIT8009NR	GRID Q
01048KIT8009SKY	GRID Q SKY

RACING HARNESSES KAYAKING



OUTLET	TEAMWEAR & LIFESTYLE	TEAMWEAR & LIFESTYLE	e-SPORTS	PERFORMANCE	KARTING	KARTING	RACING	RACING
	CAPSULE COLLECTIONS	CLOTHING ACCESSORIES	SIM RACING CHAIRS	SEATS HARNESSES STEERING WHEELS	SHOES / GLOVES PROTECTIONS	SUITS UNDERWEAR	MECHANICS TECHNICAL	HARNESSES STEERING WHEELS

HARNESSES INDEX

MADE IN ITALY

HOMOLOGATION 8853-2016

FORMULA

FORMULA H-10

TYPE: FORMULA
FIXING: DOGBONE / BOLT ON
ANCHORAGE POINT: 6 POINTS



FORMULA H-9 INDY **NEW**

TYPE: FORMULA
FIXING: DOGBONE ON SHOULDER / BOLT ON
ANCHORAGE POINT: 8 POINTS



FORMULA H-9

TYPE: FORMULA
FIXING: DOGBONE ON SHOULDER / BOLT ON
ANCHORAGE POINT: 6 POINTS



FORMULA H-8

TYPE: FORMULA
FIXING: DOGBONE ON SHOULDER / BOLT ON
ANCHORAGE POINT: 6 POINTS



FORMULA H-7

TYPE: FORMULA
FIXING: ROLLAGE / BOLT ON
ANCHORAGE POINT: 6 POINTS



PRO RALLY / GT / SALOON

PRO H-9

TYPE: RALLY / GT / SALOON
FIXING: ROLLAGE / CARABINER / DOGBONE (ON DEMAND)
ANCHORAGE POINT: 6 POINTS



PRO H-8 ENDURANCE

TYPE: RALLY / GT / SALOON
FIXING: BOLT ON / ROLLAGE / DOGBONE (ON DEMAND)
ANCHORAGE POINT: 6 POINTS



COMPETITION RALLY / GT / SALOON

COMPETITION H-3+2

TYPE: RALLY / GT / SALOON
FIXING: ROLLAGE / SNAP ON
ANCHORAGE POINT: 6 POINTS



COMPETITION H-3 STEEL **NEW**

TYPE: RALLY / GT / SALOON
FIXING: ROLLAGE / SNAP ON
ANCHORAGE POINT: 6 POINTS



COMPETITION H-2 PU **NEW**

TYPE: RALLY / GT / SALOON
FIXING: ROLLAGE / SNAP ON
ANCHORAGE POINT: 6 POINTS



COMPETITION H-2 PD

TYPE: RALLY / GT / SALOON
FIXING: ROLLAGE / SNAP ON
ANCHORAGE POINT: 6 POINTS



8854-1998

SPORT RALLY / SALOON / HISTORICAL

SPORT H-4

TYPE: RALLY / SALOON
FIXING: ROLLAGE / SNAP ON
ANCHORAGE POINT: 4 POINTS



SFI

SPORT OFFROAD / OFFSHORE

SPORT H-5 SFI / SFI CAMO

TYPE: OFFROAD / OFFSHORE
FIXING: ROLLAGE / SNAP ON
ANCHORAGE POINT: 5 POINTS





MANUFACTURER: SPARCO
MODEL: 04822H
HOM. NO: SH.060.19-T-6
FIA STANDARD: 8853-2016

HOMOLOGATION: FIA 8853-2016

ON DEMAND

HIGHLIGHTS

- 6-Point or 8-Point belt.
- 2" specific FHR shoulder straps.
- Full release titanium buckle.
- Aluminum adjusters.
- Dogbone fixing (screw fixing on request).
- Oracle Red Bull Racing F1 Team and McLaren F1 Racing Team official equipment.

THE LIGHTEST IN FORMULA 1



04822HNR



RACING HARNESES

RACING MECHANICS TECHNICAL

KARTING SUITS UNDERWEAR

KARTING SHOES / GLOVES PROTECTIONS

PERFORMANCE SEATS HARNESES STEERING WHEELS

e-SPORTS SIM RACING CHAIRS

TEAMWEAR & LIFESTYLE CLOTHING ACCESSORIES

TEAMWEAR & LIFESTYLE CAPSULE COLLECTIONS

OUTLET

FORMULA H-9



HOMOLOGATION: FIA 8853-2016



MANUFACTURER: SPARCO
MODEL: 04833H
HOM. NO: SH.073.19-T-6
FIA STANDARD: 8853-2016

€ 2.800,00
VAT not included

HIGHLIGHTS

- 6 point seat belt for single-seater.
- 2" specific FHR straps.
- Pecific f1 straps and aluminum adjusters.
- Luminum buckle with fixed point on abdominal.
- Fixing with adjustable double tongue.
- f1 straps and aluminum adjusters.



04833HNR

FORMULA H-8



MANUFACTURER: SPARCO
MODEL: 04823HNR
HOM. NO: SH.054.18-T-6
FIA STANDARD: 8853-2016

HOMOLOGATION: FIA 8853-2016

€ 350,00
VAT not included

HIGHLIGHTS

- 6 point seat belt for single-seater.
- 2" specific FHR straps.
- Aluminum buckle.
- Aluminum adjusters only on shoulder straps.
- Adjustable abdominal and thigh straps.
- Triangle screw fixings, 15 mm diameter hole, roll-cage or dog bone mounting possible by eliminating triangles.



04823HNR

FORMULA H-9 INDY **NEW**

HOMOLOGATION: FIA 8853-2016



MANUFACTURER: SPARCO
MODEL: 04843H
HOM. NO: SH.XXX.23-T-8
FIA STANDARD: 8853-2016

ON DEMAND

HIGHLIGHTS

- INDY CAR specific 8-point harness.
- Shoulder straps derived from Formula 1.
- 2" FHR Shoulder straps.
- Aluminum buckle.
- Adjusters derived from F1.
- Straps attachment to DOGBONE.
- Abdominal and thigh strap fixings.



04843NR

FORMULA H-7



MANUFACTURER: SPARCO
MODEL: 04819H
HOM. NO: SH.017.17-T-6
FIA STANDARD: 8853-2016

HOMOLOGATION: FIA 8853-2016

€ 240,00
VAT not included

HIGHLIGHTS

- 6 point seat belt for single-seater.
- 2" specific FHR straps.
- Aluminum buckle.
- Steel adjusters on shoulder and abdominal straps.
- Triangle screw fixings, 15 mm diameter hole, roll-cage or dog bone mounting possible by eliminating triangles.



- 04819H2NR
- 04819H2RS
- 04819H2AZ

PRO H-9

HOMOLOGATION: FIA 8853-2016



MANUFACTURER: SPARCO
MODEL: 04825H
HOM. NO: SH.071.19-T-6
FIA STANDARD: 8853-2016

€ 400,00
VAT not included

HIGHLIGHTS

- 6 point harness.
- 2" FHR specific straps.
- Compact T-bar.
- Aluminum buckle.
- Aluminum adjusters.
- Rollcage fasteners (shoulders and thigh) and ultra-light carabiner (abdominal).
- **WRC M-Sport Racing Team** and **WEC Peugeot Team** official harnesses equipment.



● 04825HNR
● 04825HRS

PRO H-8 ENDURANCE

HOMOLOGATION: FIA 8853-2016



MANUFACTURER: SPARCO
MODEL: 04835H
HOM. NO: SH.085.21-T-6
FIA STANDARD: 8853-2016

€ 330,00
VAT not included

HIGHLIGHTS

- 6-point endurance belt.
- 2" Specific FHR shoulder straps.
- Compact T-bar.
- Aluminum buckle.
- Aluminum adjuster on shoulder straps.
- Steel adjuster on thigh and abdomen.
- Screw fasteners on all branches.
- Roll fixing bars for shoulder straps and leg harnesses.
- Official Dallara Stradale harness equipment.



04835HNR



RACING

HARNESSES

RACING

MECHANICS
TECHNICAL

KARTING

SUITS
UNDERWEAR

KARTING

SHOES / GLOVES
PROTECTIONS

PERFORMANCE

SEATS
HARNESSES
STEERING WHEELS

e-SPORTS

SIM RACING
CHAIRS

TEAMWEAR
& LIFESTYLE

CLOTHING
ACCESSORIES

TEAMWEAR
& LIFESTYLE

CAPSULE
COLLECTIONS

OUTLET

COMPETITION H-3+2

HOMOLOGATION: FIA 8853-2016

HIGHLIGHTS

- 6 point seat belt.
- 3" specific FHR shoulder straps with reduction to 2".
- Aluminum buckle.
- Steel shoulder and abdominal strap adjusters.
- Snap-hook fasteners on all straps.
- Possibility of fixing to rollcage on shoulder straps and leg loops by removing the accessories.



MANUFACTURER: SPARCO
MODEL: 04818RH
HOM. NO: SH.005.16-T-6
FIA STANDARD: 8853-2016

- 04818RH1NR
- 04818RH1RS
- 04818RH1AZ



€ 220,00
VAT not included

COMPETITION H-2 PU

NEW

HOMOLOGATION: FIA 8853-2016

HIGHLIGHTS

- 6 point harness.
- 2" FHR Shoulder straps.
- Compact Tbar.
- Aluminum buckle.
- Pull up adjustment on abdominals.
- Steel adjusters.
- Snap-on for all straps.



MANUFACTURER: SPARCO
MODEL: 04821H
HOM. NO: SH.019.17-T-6
FIA STANDARD: 8853-2016

€ 199,00
VAT not included

- 04821H1NR
- 04821H1RS
- 04821H1AZ



COMPETITION H-3 STEEL

NEW

HOMOLOGATION: FIA 8853-2016

HIGHLIGHTS

- 6 point harness.
- Aluminum buckle.
- PULLDOWN abdominal adjustment with integrated tongue.
- 3" straps with steel adjuster.
- Snap-on for all straps.



MANUFACTURER: SPARCO
MODEL: 04834HPD
HOM. NO: SH.076.20-T-6
FIA STANDARD: 8853-2016

- 04834HPDRACNR
- 04834HPDRACRS
- 04834HPDRACAZ

€ 235,00
VAT not included



COMPETITION H-2 PD

HOMOLOGATION: FIA 8853-2016

HIGHLIGHTS

- 6 point harness.
- 2" FHR specific straps.
- Aluminum buckle.
- High resistance steel shoulder and abdominal strap adjusters.
- Pull down adjustment on abdominals by integrated pull adjusters.
- Snap hooks or rollcage fixing by removing the accessories.
- Compact T-Bar.



MANUFACTURER: SPARCO
MODEL: 04834HPD
HOM. NO: SH.076.20-T-6
FIA STANDARD: 8853-2016

€ 199,00
VAT not included

- 04834HPDNR
- 04834HPDRS
- 04834HPDAZ



SPORT H-4

HOMOLOGATION: FIA 8854-1998



€ 200,00
VAT not included

HIGHLIGHTS

- 4 point seat belt.
- 3" shoulder straps.
- Aluminum buckle.
- High resistance steel shoulder and abdominal strap adjusters.
- Snap-hook fasteners on all straps or rollcage fixing on shoulder straps by removing the accessories.



- 04716M1NR
- 04716M1RS
- 04716M1AZ

SPORT H-5

SFI CAMO

HOMOLOGATION: SFI 16.1

€ 165,00
VAT not included

HIGHLIGHTS

- 5 point seat belt.
- 3" shoulder straps.
- Latch-n-link buckle.
- High resistance steel shoulder and abdominal strap adjusters.
- Ideal for off-road vehicles and/or boats.



04806SFIVDM

SPORT H-5

SFI

HOMOLOGATION: SFI 16.1

€ 145,00
VAT not included

HIGHLIGHTS

- 5 point seat belt.
- 3" shoulder straps.
- Latch-n-link buckle.
- High resistance steel shoulder and abdominal strap adjusters.
- Ideal for off-road vehicles and/or boats.



- 04806SFINR
- 04806SFIVD

ACCESSORIES

HOMOLOGATION: FIA 8853-2016

€ 23,00
VAT not included

PAIRS OF SHOULDER PADS

- Pair of pads for 3" harnesses. Made of padded velour. NOT FIREPROOF.



■ 01098S3R

■ 01098S3A

■ 01098S3N

€ 4,00
VAT not included

EYEBOLT

Thread 7/16



04501

REINFORCEMENT FIXING PLATE

Thread 7/16



04502

DARFING STEERING WHEELS

KAGUING

OUTLET	TEAMWEAR & LIFESTYLE	TEAMWEAR & LIFESTYLE	e-SPORTS	PERFORMANCE	KARTING	KARTING	KARTING	RACING	RACING
	CAPSULE COLLECTIONS	CLOTHING ACCESSORIES	SIM RACING CHAIRS	SEATS HARNESSES STEERING WHEELS	SHOES / GLOVES PROTECTIONS	SUITS UNDERWEAR	MECHANICS TECHNICAL	STEERING WHEELS	

STEERING WHEELS INDEX

MADE IN ITALY

F-10C

TYPE: FORMULA
DIAMETER (MM): 270



015PC270SSN

F-10A

TYPE: FORMULA
DIAMETER (MM): 270



015P270SSN

P310/P310 OPEN

TYPE: FORMULA / SALOON
DIAMETER (MM): 310



015P310F2SN



015P3100PN

P300

TYPE: FORMULA / SALOON
DIAMETER (MM): 300



015P300SN

R323

TYPE: RALLY / SALOON
DIAMETER (MM): 270



015R323PSNR

R330 / R330B

TYPE: FORMULA / SALOON
DIAMETER (MM): 330



015R330CSO



015R330CLO



015R330PSO

R350 / R350B

TYPE: FORMULA / SALOON
DIAMETER (MM): 350



015R350CSO



015R350CLO



015R350PSO

R215 / R215 FLAT

TYPE: RALLY
DIAMETER (MM): 350



015R215CSN



015R215FL



015R215FS

R325

TYPE: RALLY
DIAMETER (MM): 350



015R325CSN

R345

TYPE: RALLY
DIAMETER (MM): 350



015R345MLN

R368

TYPE: RALLY / OFF ROAD / TRUCK
DIAMETER (MM): 380



015R368MSN

R353

TYPE: RALLY / SALOON
DIAMETER (MM): 330



015R353PSN

R375

TYPE: RALLY / SALOON
DIAMETER (MM): 350



015R375PSN

R383 / R383 LOGO

TYPE: RALLY / SALOON
DIAMETER (MM): 330



015R383PSN



015R383PSNLOGO

F-10C

MATERIAL: SUEDE

HIGHLIGHTS

- Carbon steering wheel for prototype single-seater and sports vehicle.
- Ergonomic grip, designed based on experience gained with the racing teams of the most prestigious motor manufacturers.
- Hole interaxis 3x50.8 mm.

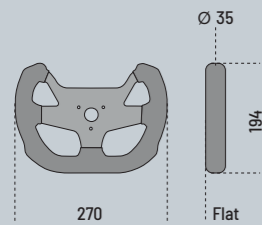

€ 363,00
VAT not included
015PC270SSN

P310

MATERIAL: SUEDE

HIGHLIGHTS

- Flat steering wheel ideal for GT car.
- Hole interaxis: 6x70 mm.

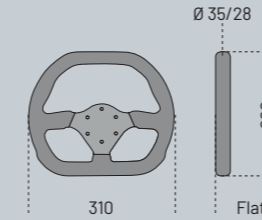

€ 229,00
VAT not included
015P310F2SN

F-10A

MATERIAL: SUEDE

HIGHLIGHTS

- Aluminium steering wheel for prototype single-seater and sports vehicle.
- Ergonomic grip, designed based on experience gained with the racing teams of the most prestigious motor manufacturers.
- Hole interaxis 3x50.8 mm.

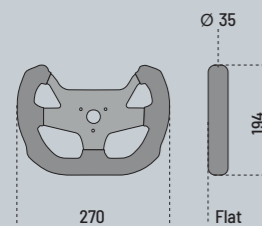

€ 213,00
VAT not included
015P270SSN

P310 OPEN

MATERIAL: SUEDE

HIGHLIGHTS

- Open top, ideal for GT cars.
- Hole interaxis: 6x70 mm.

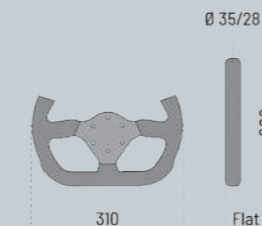

€ 219,00
VAT not included
015P310OPN

RACING	STEERING WHEELS
RACING	MECHANICS TECHNICAL
KARTING	SUITS UNDERWEAR
KARTING	SHOES / GLOVES PROTECTIONS
PERFORMANCE	SEATS HARNESSES STEERING WHEELS
e-SPORTS	SIM RACING CHAIRS
TEAMWEAR & LIFESTYLE	CLOTHING ACCESSORIES
TEAMWEAR & LIFESTYLE	CAPSULE COLLECTIONS
OUTLET	



P300

MATERIAL: SUEDE

HIGHLIGHTS

- Flat steering wheel with small grip.
- Hole interaxis: 6x70 mm.

New horn button colour kit included.

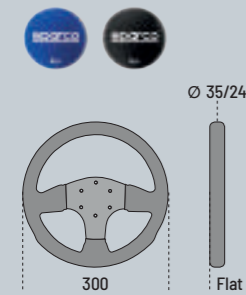

€ 223,00
VAT not included

015P300SN

R323

MATERIAL: SUEDE

HIGHLIGHTS

- Flat steering wheel with small grip.
- Hole interaxis: 6x70 mm.

New horn button colour kit included.

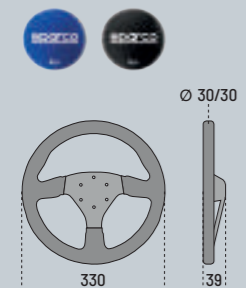

€ 234,00
VAT not included

015R323PSNR



OUTLET

TEAMWEAR & LIFESTYLE
CAPSULE COLLECTIONS

TEAMWEAR & LIFESTYLE
CLOTHING ACCESSORIES

e-SPORTS
SIM RACING CHAIRS

PERFORMANCE
SEATS HARNESSES STEERING WHEELS

KARTING
SHOES / GLOVES PROTECTIONS

KARTING
SUITS UNDERWEAR

RACING
MECHANICS TECHNICAL

RACING
STEERING WHEELS

R330 / R330 B

MATERIAL: SUEDE / LEATHER

HIGHLIGHTS

- Hole interaxis: 6x70 mm.

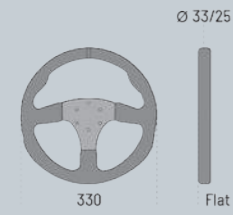

WITHOUT BUTTONS

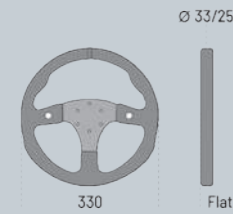

WITH BUTTONS

€ 213,00
VAT not included
015R330CLO
LEATHER WITHOUT BUTTONS

€ 189,00
VAT not included
015R330CSO
SUEDE WITHOUT BUTTONS

- IP68 buttons for water and dust protection.

€ 189,00
VAT not included
015R330PSO
SUEDE + BUTTONS



R215

MATERIAL: SUEDE

HIGHLIGHTS

- Dished steering wheel with lighter spokes.
- Hole interaxis: 6x70 mm.

New horn button colour kit included.

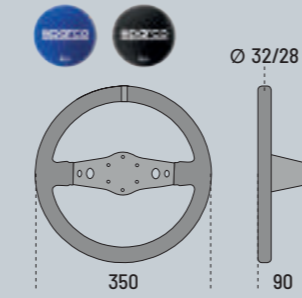

€ 177,00
VAT not included
015R215CSN



R350 / R350 B

MATERIAL: SUEDE / LEATHER

HIGHLIGHTS

- Hole interaxis: 6x70 mm.

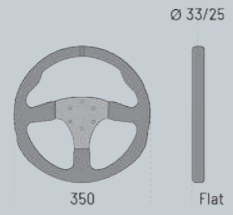

WITHOUT BUTTONS

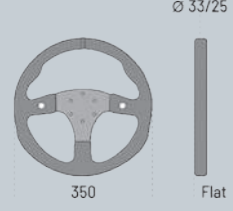

WITH BUTTONS

€ 213,00
VAT not included
015R350CLO
LEATHER WITHOUT BUTTONS

€ 198,00
VAT not included
015R350CSO
SUEDE WITHOUT BUTTONS

- IP68 buttons for water and dust protection.

€ 199,00
VAT not included
015R350PSO
SUEDE + BUTTONS



R215 FLAT

MATERIAL: SUEDE / LEATHER

HIGHLIGHTS

- Suede flat steering wheel for rally use.
- Hole interaxis: 6x70 mm.

New horn button colour kit included.

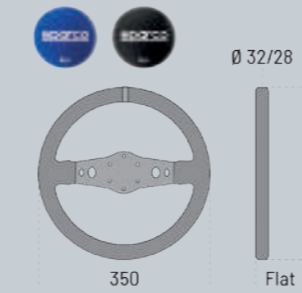

€ 209,00
VAT not included
015R215FL
LEATHER

€ 188,00
VAT not included
015R215FS
SUEDE



R325

MATERIAL: SUEDE

HIGHLIGHTS

- Dished steering wheel with three spokes and small grip.
- Hole interaxis: 6x70 mm.

New horn button colour kit included.

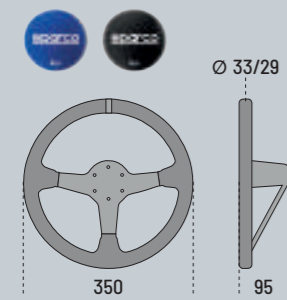

€ 213,00
VAT not included
015R325CSN

R368

MATERIAL: SUEDE

HIGHLIGHTS

- Dished steering wheel optimal for off-road use.
- Hole interaxis: 6x70 mm.

New horn button colour kit included.

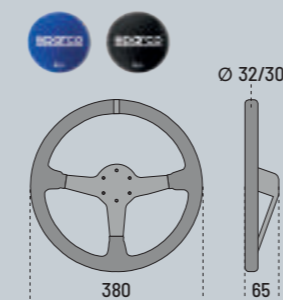

€ 234,00
VAT not included
015R368MSN

R345

MATERIAL: SUEDE / LEATHER

HIGHLIGHTS

- Dished steering wheel with small grip.
- Hole interaxis: 6x70 mm.

New horn button colour kit included.

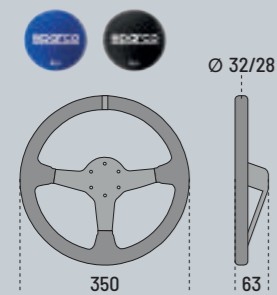

€ 198,00
VAT not included
015R345MLN
LEATHER
€ 177,00
VAT not included
015R345MSN
SUEDE



R353

MATERIAL: SUEDE

HIGHLIGHTS

- Dished steering wheel with large grip.
- Hole interaxis: 6x70 mm.

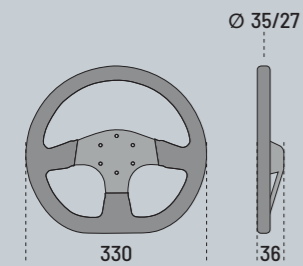

€ 223,00
VAT not included

015R353PSN



R383 LOGO

MATERIAL: SUEDE

HIGHLIGHTS

- Steering wheel with special comfortable grip shape.
- Hole interaxis: 6x70 mm.

New horn button colour kit included.

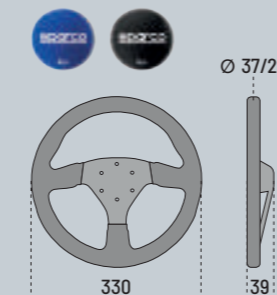

€ 245,00
VAT not included

015R383PSNLOGO



R375

MATERIAL: SUEDE

HIGHLIGHTS

- Special 36 mm dished.
- Hole interaxis: 6x70 mm.

New horn button colour kit included.

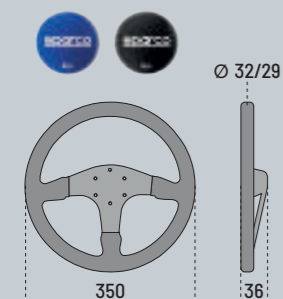

€ 234,00
VAT not included

015R375PSN



R383

MATERIAL: SUEDE

HIGHLIGHTS

- Steering wheel with special comfortable grip shape.
- Hole interaxis: 6x70 mm.

New horn button colour kit included.

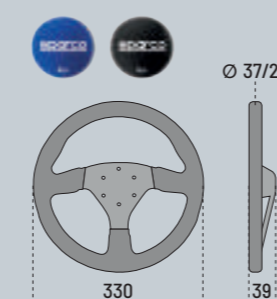

€ 234,00
VAT not included

015R383PSN



ACCESSORIES

PRE-WIRED QUICK RELEASE

€ 400,00
VAT not included

- Wire harness with silver solder connection with LEMO connectors from F1.
- CNC machined aircraft aluminum.
- Hard anodizing for strength and reliability.
- Drilling for assembly 6x70mm.
- FIA compliant (Annex J).



015R98EL

QUICK RELEASE

€ 225,00
VAT not included

- CNC processed aeronautical aluminium.
- Hard anodised for resistance and reliability.
- Slots for 6x70 mm mount.
- FIA compliant (annex J).



015R98R

SW PAD

Steering wheel protection pad.
FIA compliant (annex J).

€ 99,00
VAT not included



015002NR



HORN DELETE KIT

€ 44,00
VAT not included

€ 44,00
VAT not included

HORN DELETE KIT MATT



0159ZMNR



HORN DELETE KIT GLOSSY



0159ZNR

RING

€ 38,00
VAT not included



01599NR

ANODIZED STEERING WHEEL SPACERS

€ 87,00
VAT not included

ANODIZED ALUMINIUM



01595ANR



01595ANT

RACING PUSH BUTTONS KIT

€ 38,00
VAT not included

€ 53,00
VAT not included

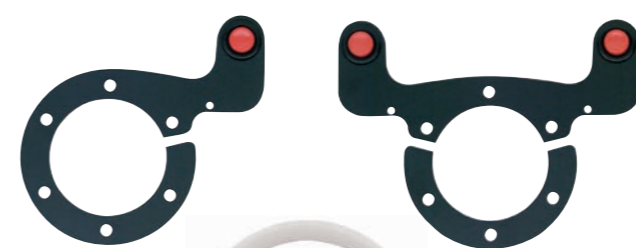

015NE981

015NE982

STEEL WHEEL HUB

FOR THE APPLICATION LIST
PLEASE CHECK PRICE LIST.

Sparco collapsible hubs are made from cast iron with a steel frame that collapse during impacts. This item absorbs kinetics energy avoiding transfer to the driver.

The Sparco steering wheels are TÜV approved only if coupled with the Sparco hubs.

