









An Installation for disassembly 270° revolving basket

LIST OF FITTINGS

DESCRIPTION	CODE	QTY
	A	2 PCS
 (ø32×545mm)	B	1 PCS
 (ø29×250mm)	C	1 PCS
	D	2 PCS
	E	2 PCS
	F	2 PCS
	G	2 PCS
 ST4×14	H	8 PCS
 (ø5×49mm)	I	2 PCS

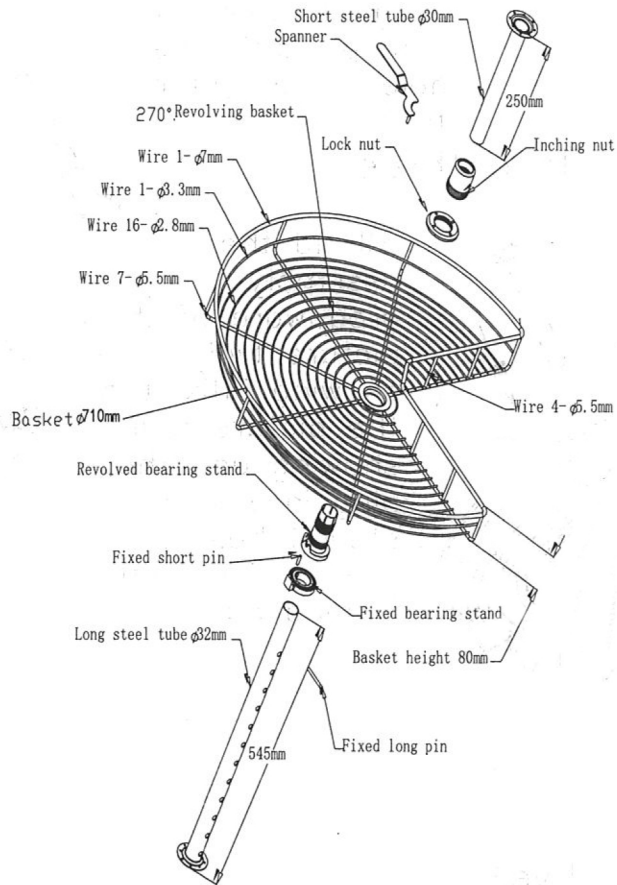
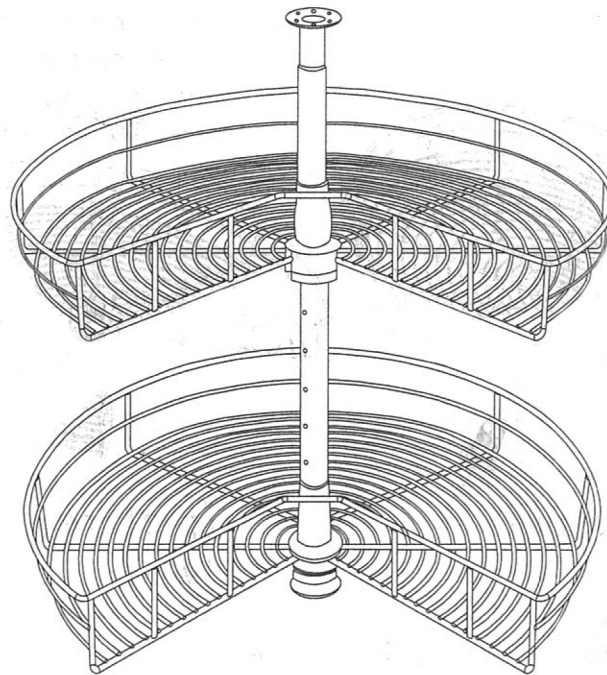

An Installation for disassembly 270°/360°.revolving basket

1)Fit in according to the sequence of picture one,and use spanner aim at the hole in the nut and clamp the revolving basket.



(picture one)

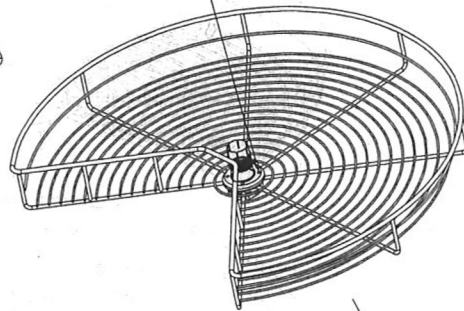

(picture two)

Note: fixed support trough and steel wire(as the arrowhead show)clamp position,as the magnify picture.

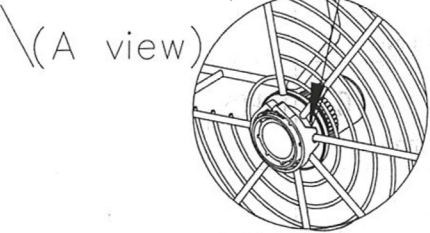

(A view)

A.magnify view

2)Hold the locomotors nut of fixed short pin infix the long steel tube,and then begin to go to use fixed long pin infix the hole of long steel tube.

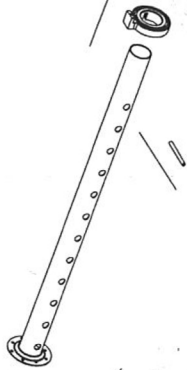

(picture three)

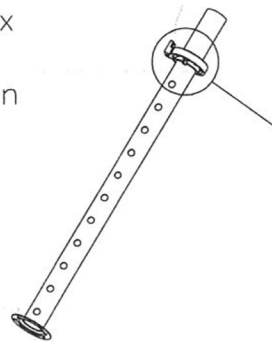

(picture four)

3)Hold the assembly groupware of the picture two showing infix it of the picture four showing and the plug into short steel tube,and lock it tight with inching nut.

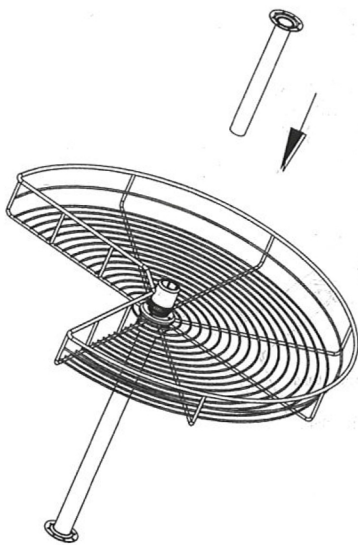

(picture five)

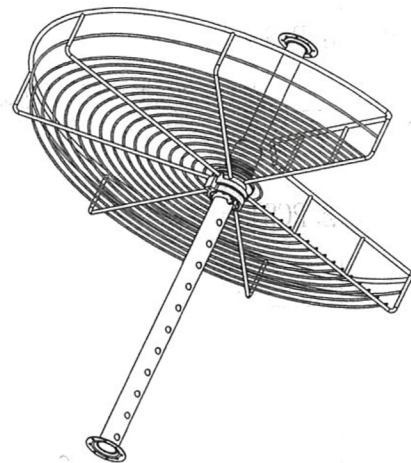

(picture six)