

Vegas Stars and Diamonds

50" x 58"

Fabric Requirements

Vegas Strips

Fabric A (cream) – 5 strips

Fabric B (blue) – 11 strips

Fabric C (red) – 5 strips

Yardage

Fabric A (cream) – 7/8 yard

Fabric B (red) – 1 1/2 yard

Fabric C (blue) – 1 5/8 yard

Backing Fabric – 4 yards

Binding Fabric – 1/2 yard

©2023 All Rights Reserved by Sew Yeah Quilting and Breezdesigns.
Reproduction in whole or in part in any language without written permission from Sew Yeah Quilting and/or Breezdesigns is prohibited. No one may copy, reprint or distribute any of this pattern for commercial use without written permission of Sew Yeah Quilting and/or Breezdesigns. Anything you make using this pattern or ideas is your business, do whatever you want with the stuff you make, it's yours.

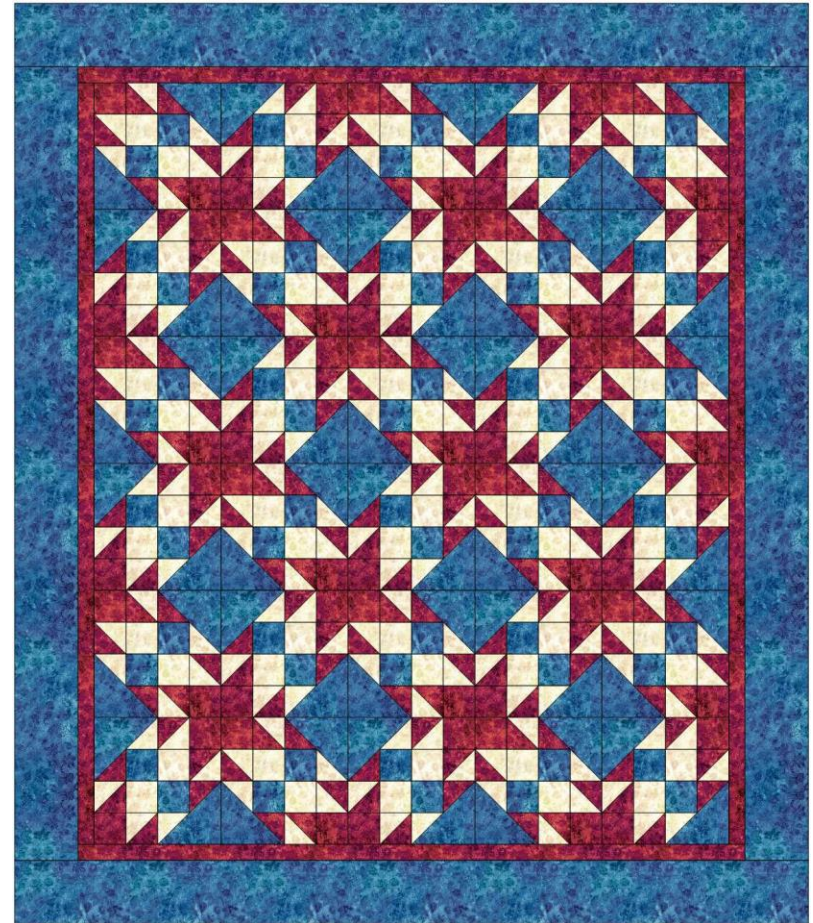

Cutting Instructions:

Follow the diagrams on this page and the next page on how to cut each 6 1/2" Vegas Strip. When you cut each strip leave them folded from selvage to selvage. **Note:** If using yardage, just follow the same instructions, except you will cut all your strips the width of fabric (WOF) from selvage to selvage.

Fabric A (cream) –

4"	2 1/2"	Note: You are cutting three Vegas Strips exactly the same.	2 7/8"	2 7/8"	Note: You are cutting three Vegas Strips exactly the same.	2 1/2"	Note: You are cutting three Vegas Strips exactly the same.	
4"	2 1/2"		2 7/8"	2 7/8"		2 1/2"		
4"	2 1/2"		2 7/8"	2 7/8"		2 1/2"		
4"	2 1/2"		2 7/8"	2 7/8"		2 1/2"		
4"	2 1/2"		2 7/8"	2 7/8"		2 1/2"		
4"	2 1/2"		2 7/8"	2 7/8"		2 1/2"		
4"	2 1/2"		2 7/8"	2 7/8"		2 1/2"		
4"	2 1/2"		2 7/8"	2 7/8"		2 1/2"		
Cut one 4" strip. Subcut into ten 4" squares. Cut one 2 1/2" strip. Subcut each strip into sixteen 2 1/2" squares.			Cut two 2 7/8" strips. Subcut each strip into fourteen 2 7/8" squares.			Cut one 2 1/2" strip. Subcut into sixteen 2 1/2" squares. Then cut two 2 7/8" squares.		

Fabric B (blue) –

2 1/2"	2 1/2"	Note: You are cutting two Vegas Strips exactly the same.	4 7/8"	Note: You are cutting four Vegas Strips exactly the same.	4 1/2"	Note: You are cutting five Vegas Strips exactly the same.		
2 1/2"	2 1/2"		4 7/8"		4 1/2"			
2 1/2"	2 1/2"		4 7/8"		4 1/2"			
2 1/2"	2 1/2"		4 7/8"		4 1/2"			
2 1/2"	2 1/2"		4 7/8"		4 1/2"			
2 1/2"	2 1/2"		4 7/8"		4 1/2"			
2 1/2"	2 1/2"		4 7/8"		4 1/2"			
2 1/2"	2 1/2"		4 7/8"		4 1/2"		4 1/2"	
Cut four 2 1/2" strips. Subcut each strip into sixty 2 1/2" squares.			Cut four 4 7/8" strips. Subcut each strip into thirty 4 7/8" squares.			Cut five 4 1/2" strips. These will be used for the outer border.		

Cutting Instructions (cont'd):

Fabric C (red) –

	<p>Note: You are cutting three Vegas Strips exactly the same.</p>		
<p>Cut one 4" strip. Subcut into ten 4" squares. Cut one 2 1/2" strip. Subcut each strip into sixteen 2 1/2" squares.</p>	<p>Cut two 2 1/2" strips. Subcut each strip into sixteen 2 1/2" squares. There will be a 1 1/2" strip left that will be used for the inner border.</p>	<p>Cut two 2 7/8" strips. Subcut each strip into fourteen 2 7/8" squares.</p>	

<p>Cut one 2 1/2" strip. Subcut into sixteen 2 1/2" squares. Then cut two 2 7/8" squares.</p>	<p>Cut four 1 1/2" strips. These will be used for the inner border.</p>

<p>Fabric A (cream)</p>	<p>Fabric B (blue)</p>	<p>Fabric C (red)</p>
<p>Cut all thirty 2 7/8" squares diagonally from corner to corner. This should yield sixty Half Square Triangles used in Block 2.</p>	<p>Cut all thirty 4 7/8" squares diagonally from corner to corner. This should yield sixty Half Square Triangles used in Block 2.</p>	<p>Cut all thirty 2 7/8" squares diagonally from corner to corner. This should yield sixty Half Square Triangles used in Block 2.</p>

Sewing Instructions:

Half Square Triangles (HSTs) – For Block 1

Pair up all the 4” squares (Fabrics A, C) with right sides together. Follow the three steps below.

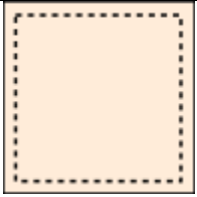
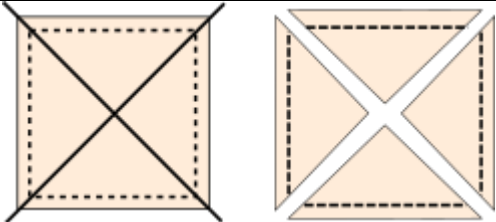
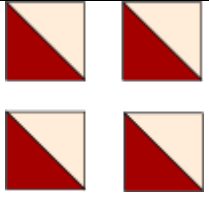
		
<p>Step 1: Stitch around all four sides using a 1/4” seam allowance.</p>	<p>Step 2: Cut diagonally from corner to corner in both directions.</p>	<p>Step 3: Press them to the darker fabric.</p>

Assemble Block 1:

Lay your HST squares and 2 1/2” squares as shown below. Now, sew row 1 and press towards the square. Sew the next row and press towards the square (Figure 1). Sew the rows together and press towards the second row (Figure 2). Make a total of 60 blocks (Figure 3). Set them aside.

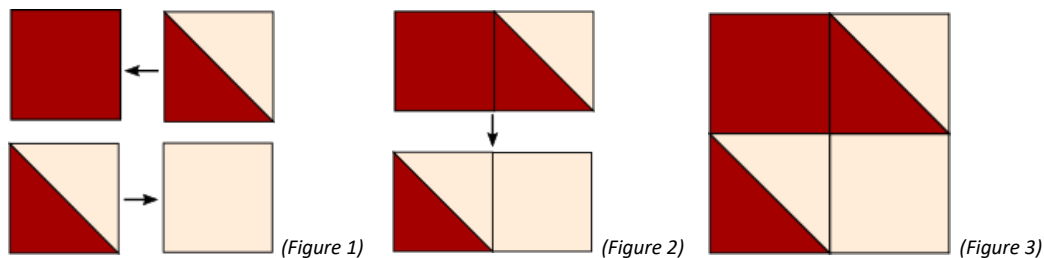

Assemble Block 2:

Lay your triangles and square as shown below. First, flip the top triangle onto the square aligning the sides (Figure 1). The tip will hang off slightly. Stitch across then press towards the triangle. Next, flip the side triangle onto the square (Figure 2). Stitch across then press towards the triangle. Lastly, flip the large triangle (Figure 3) and line it up with the lower left corner. Stitch across then press towards the triangle for 33 blocks and press towards the pieced half for the remaining 27 blocks. Make a total of 60 blocks (Figure 4). Set them aside.

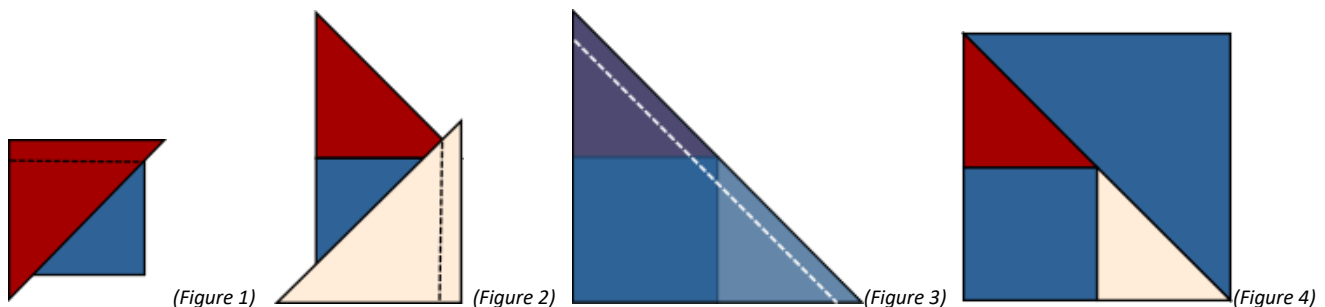

Assemble Rows:

Lay your blocks as shown below. Sew all your rows together, press each row in the direction of the arrows shown in Figure 1. Pressing this way will help in nesting the rows as you sew row to row.

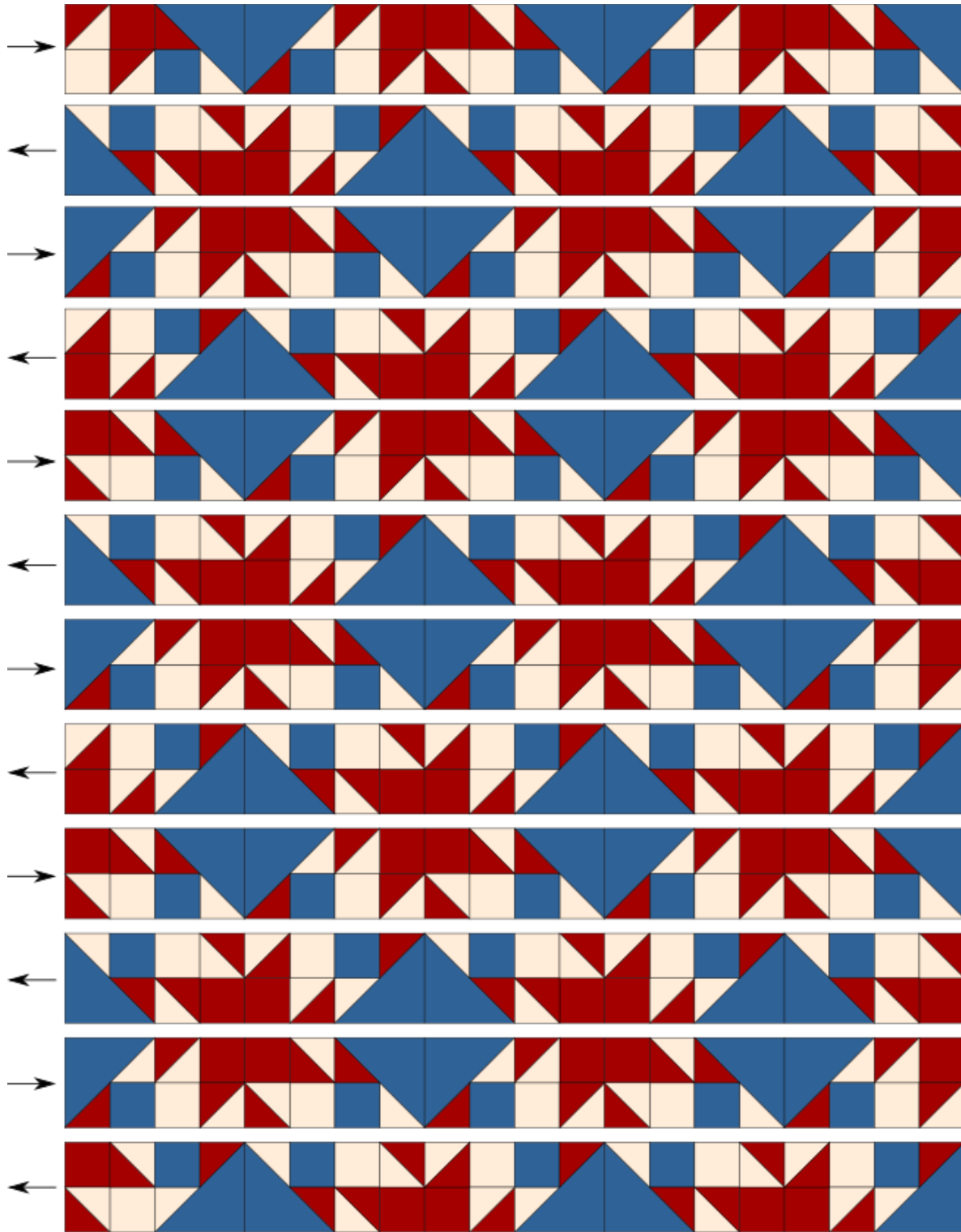

(Figure 1)

Add the Inner and Outer Borders:

Sew three of the 1 1/2" strips from Fabric C together into one long strip, then subcut two of the strips that measure 1 1/2" x 48 1/2" each. Next, take the remaining two 1 1/2" strips and subcut them to measure 1 1/2" x 42 1/2". Sew the longer strips to the left and right side first pressing towards the border, then sew the shorter strips to the top and bottom pressing them towards the border.

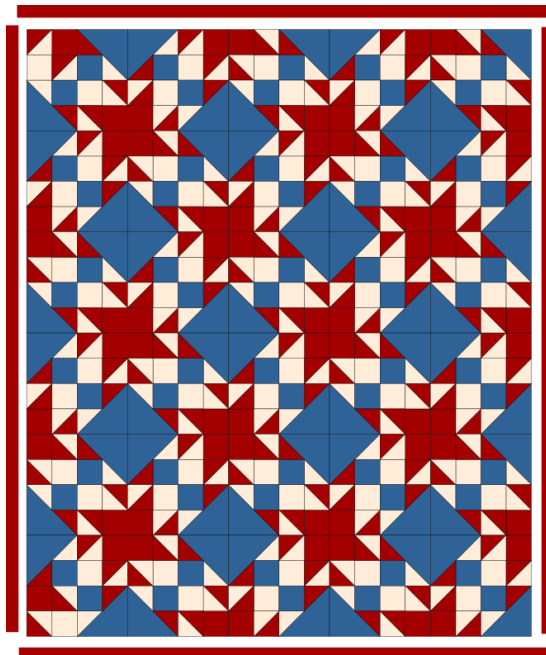

For the outer border, sew all five strips cut earlier from Fabric B and sew them into one long strip. From this strip, subcut four strips measuring 1 1/2" x 50". Sew a strip to the left and right side of the quilt, then press towards the border. Sew the last two strips to the top and bottom, then press towards the border. Your quilt top is now complete. Quilt as desired and enjoy.

