

MXR FLOWMETER USER'S MANUAL

Instructions and Safety Considerations MXR Models of Porter Conscious Sedation Flowmeters and Bag Tee (Accessory)

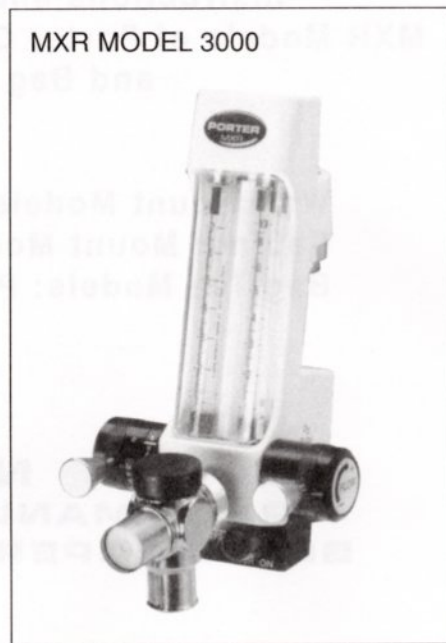

Wall Mount Models:

2000
2000-OS
3000

Bag Tee Models:

P1407A
P2407A
P1407B

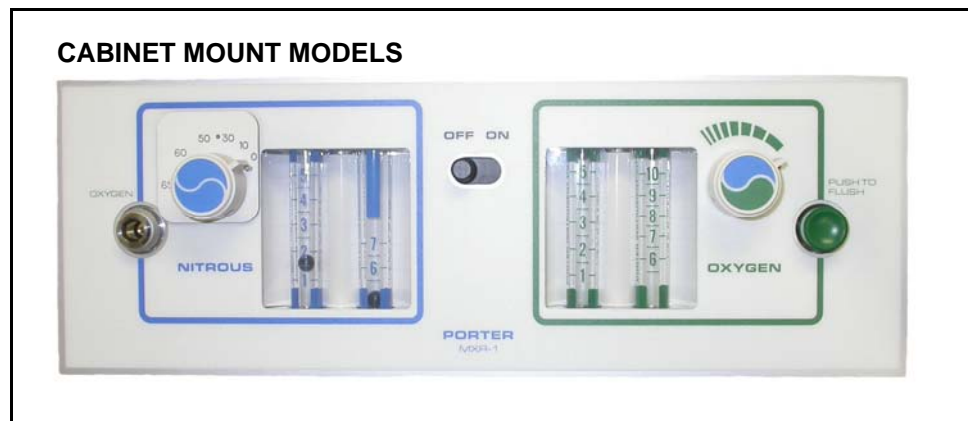

Cabinet Mount Models:

2050W, 2055W, 2060W, 2066W, 2065W, 2070W, 3065W and 3066W



PORTER

Parker Hannifin Corporation
Porter Instrument Division
245 Township Line Rd.
P.O. Box 907
Hatfield, PA 19440-0907 USA
(215) 723-4000 / fax (215) 723-5106

Table of Contents

Features and Specifications.....	2
Partial Listing of Reference Materials	2
Warnings and Precautions.....	3
Cross Lines Warning.....	4
Do not Allow Crossed Lines to Defeat Equipment Safety Features Illustration	5
Safety: ADA Guidelines / NFPA Codes	6
Intended Use – Flowmeter for Analgesia Delivery System.....	6
Use Scavenging.....	6
Gas Supply Connection	6
Monthly Leak Check	6
Flowmeter Mounting Options	7 - 8
Wall Mount	7
Cabinet Mount.....	7
Slide Away	7
Mobile Stand and E-Stand	8
MXR Flush Mount Flowmeter	8
Oral Surgery MXR Model 2000-OS.....	8
Flowmeter Accessories.....	8 – 9
Three Liter Bag	8
Positive Pressure / Demand Valve.....	8
Gas Scavenging Breathing Circuit	9
Automatic Vacuum Switch (AVS).....	9
In-Line Vacuum Control Kit	9
Flowmeter Features	10
Safety Feature Checks	11
Nitrous Oxide Failsafe System (Check Before Each Use)	11
Concentration Control Knob Valve (Check Monthly)	11
Power Oxygen Flush (Check Monthly)	12
Quick Test to Check 3 Liter Bag / Rubber Goods for Leaks	12
Bag Tee	12 – 13
Non-Rebreathing Valve (Check Monthly).....	13
Emergency Air Valve (Check Monthly).....	13
Monthly Calibration Check	13
Directions for Use	14 – 15
Basic Delivery Technique.....	15
Maintenance and Service	15
Cleaning Methods.....	15
Troubleshooting Chart	16
Warranty and Returns.....	17

MXR FLOWMETER FEATURES AND SPECIFICATIONS

Flowmeter Type	Model Number(s)	Maximum N₂O Concentration
Upright	2000, 2000-OS & 3000	70%
Cabinet Mount	2050W, 2055W, 2060W, 2065W, 2070W & 3065W	65%
Special Cabinet Mount	2066W & 3066W	50%

Flowmeter: Indicates flow in L/min and percent N₂O of total flow with accuracy of \pm 5%. Includes Diameter Index Safety System (DISS) for N₂O and O₂ connectors.

Flowmeter Tubes: Direct reading flow tubes for Oxygen and Nitrous Oxide for accurate, visual flow readings.

Dual Seal Fail-Safe: Automatically reduces N₂O if O₂ is shut off or pressure is reduced

Gas Control Block: One-piece, solid aluminum construction. Eliminates internal gas leaks.

Gas Flow Adjustment Knobs: Control knob-type knobs for quick, accurate, one-hand adjustment of gas flows.

Emergency Air Valve: Automatically provides patient with ambient Air if gas flow is interrupted for any reason.

Non-rebreathing Check Valve: Prevents rebreathing of used gases and guards against CO₂ build-up.

Positive ON / OFF Switch: Eliminates possibility of accidentally leaving the machine on. Color- coded for Oxygen.

Oxygen Power Flush Button: Provides extra delivery of O₂. Button is accessible to override all other gas flows and deliver 100% O₂. Color-coded for Oxygen.

Flow Control knob: Total flow adjustment knob which controls flow of both N₂O and O₂ at any desired concentration. Total flow can be adjusted without affecting concentration. Includes posi-stop needle valves for adjustment of all flows—prevents damage to valves and seats.

Oxygen Quick Connect: Facilitates connection of resuscitation equipment to the central system.

PARTIAL LISTING OF REFERENCE MATERIAL

¹Handbook of Nitrous Oxide and Oxygen Sedation – Morris Clark • Ann Brunick

Dentists' Desk Reference: Materials, Instruments & Equipment - American Dental Association

Relative Analgesia in Dental: Inhalation Analgesia and Sedation with Nitrous Oxide - Harry Langa, D.D.S.

Conscious - Sedation in Dental Practice - C. Richard Bennett

Sedation - A Guide to Patient Management - Stanley F. Malamed

The Practical Use Nitrous Oxide - Oxygen Conscious Sedation - Robert E. Hamric, D.M.D

IMPORTANT:
READ MANUAL COMPLETELY BEFORE OPERATING THIS DEVICE

Basic delivery technique is described. Also, this manual contains instructions on periodically required checks to be performed by the user. These checks are necessary to insure the proper performance of this device and its safety features. Retain this manual for future reference.



WARNINGS AND PRECAUTIONS

These warnings and precautions are to help you to understand how to safely operate the MXR Flowmeter. A **WARNING** alerts you to a possible hazard to people. A **CAUTION** alerts you to the possibility of equipment damage.

WARNING: Do not use this device for the administration of general anesthesia or as a part of, or in conjunction with, a general anesthesia administration system.

WARNING: Dental workers are exposed to N₂O during administration of N₂O/O₂ conscious sedation analgesia. NIOSH has recommended that exposures should be minimized. Contact NIOSH (1-800-35-NIOSH) to receive NIOSH Publications on *Control of Nitrous Oxide in Dental Operatories*. Exposure can be minimized by effective controls. National Institute for Occupational Safety and Health (NIOSH) publications state that controls, including System Maintenance, Ventilation and Work Practices can effectively reduce N₂O concentrations in dental operations. Your flowmeter accessory Porter scavenger system is an important part of the system of controls.

WARNING: Porter Instrument equipment utilizes the **cross+protection** system. The flexible hose and connectors that connect to the flowmeter are diameter indexed; 3/8" O.D. for Nitrous Oxide and 1/2" for Oxygen. The **cross+protection** system is designed to prevent misconnection of Oxygen and Nitrous Oxide piping. **DO NOT ATTEMPT TO CHANGE THE DIAMETERS OR CONNECTORS OF THE FLOWMETER!** Tampering with the **cross+protection** system constitutes acceptance of liability by the installer.

WARNING: New or modified installations - **properly connected gas pipelines are absolutely essential to patient safety.** The dealer or contractor should provide written documentation that all gas pipelines are connected properly and that the system has been pressure tested prior to use. While this is a good business practice, it is important that the user verify by their own test, independent of the dealer or contractor, that all gas pipelines are connected correctly prior to using the system. **The ultimate responsibility of assuring that lines are not crossed rests with the user.**

WARNING: During any power outage, remember to turn OFF the flowmeter and manually turn OFF the tank valves. With centralized, electrically powered gas systems, if gas was flowing when the power went out and the flowmeter is left ON, gas will be flowing when the power is restored.

CAUTION: Federal law requires this device for use by or on the order of a physician or dentist.

CAUTION: Always use clean, dry medical grade gases. Introduction of moisture or other contaminants into this device may result in defective operation.

CAUTION: Do not attempt to repair, alter or calibrate this device. Unauthorized repair, alteration or misuse of this device is likely to adversely affect the performance and will void the warranty.

CAUTION: Never oil or grease any part of this system (minimize fire or explosion potential).



WARNING:
NEW OR MODIFIED INSTALLATIONS
ALWAYS ASSURE THAT LINES ARE NOT CROSSED!

WARNING: New or modified installations - **properly connected gas pipelines are absolutely essential to patient safety.** The dealer or contractor should provide written documentation that all gas pipelines are connected properly and that the system has been pressure tested prior to use. While this is a good business practice, it is important that the user verify by their own test, independent of the dealer or contractor, that all gas pipelines are connected correctly prior to using the system. **The ultimate responsibility of assuring that lines are not crossed rests with the user.**

Do not allow crossed lines to defeat the safety features of the dental flowmeter and/or central gas supply manifold systems. Crossed lines will create a dangerous and hazardous condition where 100% nitrous oxide will be delivered through the oxygen dental flowmeter tube and subsequently to the patient. In addition, the resuscitator quick connect would deliver 100% nitrous oxide to an oxygen demand valve.

Maintain patient observation during procedures. Prevent over sedation. If a patient becomes over sedated when being delivered 100% oxygen, it is a definite indication of crossed lines. If crossed lines are suspected, remove the nasal mask immediately and encourage mouth breathing. Deliver pure oxygen from an oxygen demand valve only if the oxygen source is independent from the suspected crossed lines area.

To check for crossed lines of an installed Porter Vanguard (or Sentinel) Manifold System:

1. At the manifold system (in the tank room), start the check from an operating system with 50 psi showing on both gauges and the indicator lights turned on – electrical operation and alarms needed for the Vanguard test. Then, turn off both oxygen tanks and leave both nitrous oxide tanks on. (For the Sentinel, only one tank of each gas is on at a time. Turn off the one open oxygen tank, leave on the one nitrous oxide tank, turn off the indicator lights – eliminates alarms during the Sentinel test.)
2. In the operatory, where the flowmeter is installed, flow 5 to 6 liters per minute of O₂ only. Verify that the N₂O flowmeter valve is in the off position and that there is no indicated flow of N₂O - by observing the ball float resting at the bottom of the glass N₂O flow tube.

This action will bleed the oxygen copper tubing lines (1/2" OD) from the manifold, through the office walls, to the flowmeter. Note: this action does not cause a quick bleed down, as there is a fair sized volume in the lines. O₂ flow would be observed by the position of the ball float in the O₂ flow tube for several minutes.

3. Rather than waiting for the O₂ flow to decrease, go back to the manifold tank room and observe the O₂ pressure gauge on the manifold (normally showing approximately 50 PSIG pressure). The line pressure should start to decrease, indicating bleeding of the O₂ that is no longer being replenished by the tanks. On Vanguard systems, the alarm will beep at 40 PSIG, a switch will occur from one tank to the second tank at 30 PSIG (increasing the gauge back to 40 PSIG). The gauge then should eventually go down to zero.

If the O₂ pressure does not go down as described above, and remains at about 50 PSIG, it indicates a crossed lines condition.

4. If O₂ pressure does not go down, proceed to the next crossed line determination check. Turn N₂O tanks off in the manifold tank room and watch the N₂O gauge. Given a crossed line condition, the N₂O gauge will now go down (the Vanguard system will show a switching similar to step 2 above) — this shows the O₂ valve of the flowmeter is bleeding the crossed N₂O lines. The N₂O gauge will go down to zero.

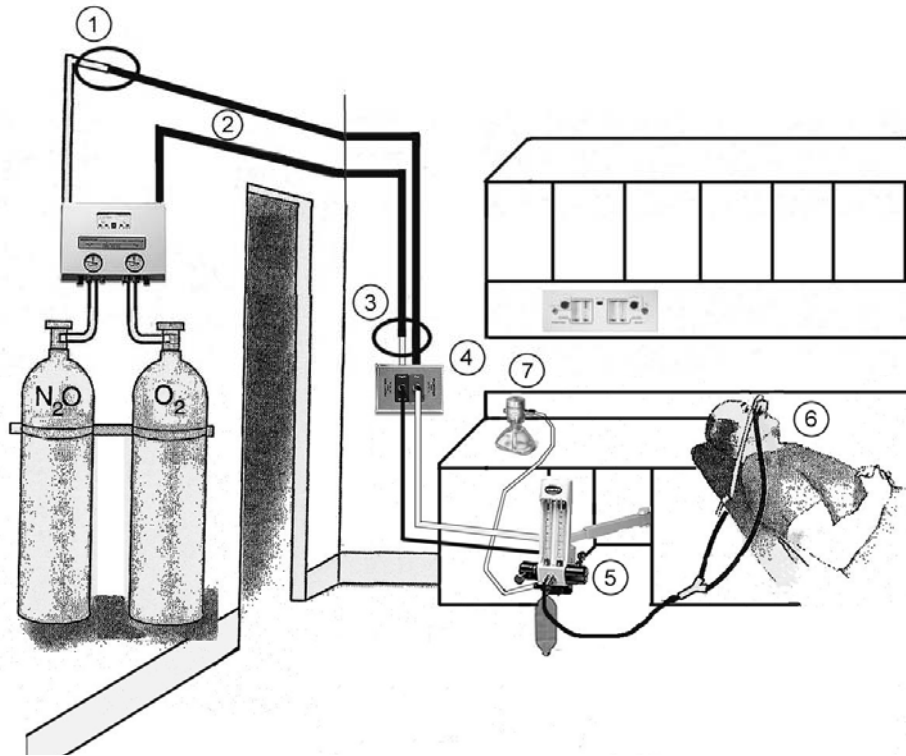

Do Not Allow Crossed Lines to Defeat Equipment Safety Features

Crossed lines in wall structure piping creates hazard of 100% Nitrous Oxide delivery to nasal mask and Oxygen demand valve when Flowmeter is set for 100% Oxygen resulting in over sedation.

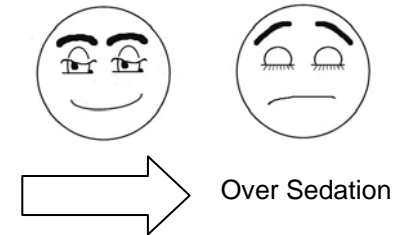

- 1** The initial installation potential problem: DISS (Diameter Index Safety System) is modified at tank room wall when 3/8 inch Nitrous Oxide pipe is increased to 1/2 inch pipe size. Oxygen pipe remains at the normal 1/2 inch size.
- 2** Both Nitrous Oxide and Oxygen piping is maintained at a common 1/2 inch size throughout the building walls leading to operatories.
- 3** At gas outlet station, the Oxygen 1/2 inch pipe is incorrectly decreased down to the DISS 3/8 inch size reserved for Nitrous Oxide lines. Oxygen is fed into the Nitrous Oxide lines.

- 4** At gas outlet station, the common run of 1/2 inch pipe for Nitrous Oxide is incorrectly allowed to remain at the 1/2 inch size and is then falsely connected to the DISS 1/2 inch outlet station. Nitrous Oxide is fed into the Oxygen lines.
- 5** Dental flowmeter valve is set for 100% Oxygen only, but will deliver 100% Nitrous Oxide because of the crossed lines.
- 6** A patient will become over sedated and may appear to fall asleep when the flowmeter is set for 100% Oxygen.
- 7** An Oxygen demand valve connected to the resuscitator quick connect of the Flowmeter will also deliver 100% Nitrous Oxide because of the crossed lines.

SAFETY:

ADA Guidelines: In addition to the fail-safe and other safety features found on most sedation machines, effective August 1976, the following specifications were added to those required for acceptance by the ADA Council on Dental Materials and Devices: 1. Emergency Air Valve; 2. Non-rebreathing Check Valve; and 3. Resuscitator Quick Connect.

In addition, the ADA Council requires that: 1. The gas storage and delivery system meet the recommendations of the National Fire Protection Association (NFPA).; 2. The system be installed by a competent supplier of gases and equipment.

NFPA Codes: To assure safe operation and conformation to local fire codes, Porter Instrument Nitrous Oxide Sedation Systems meet or exceed the guidelines established by the National Fire Protection Association for Nonflammable Medical Gas Systems, NFPA 99. Copies of NFPA 99 or portions thereof may be obtained by writing to *National Fire Protection Association, Batterymarch Park, Quincy, MA 02269-9904 USA* or call: 1-800-344-3555

INTENDED USE:

Flowmeter for Analgesia Delivery System

This device is intended for patient use by an attending physician or dentist properly trained in its use. Porter Instrument recommends the user be thoroughly familiar with the use of Nitrous Oxide - Oxygen Conscious Sedation for patient analgesia and be properly trained in its administration prior to using this product. For training requirements on the administration of Nitrous Oxide - Oxygen Conscious Sedation, contact the appropriate regulatory authority in your country, state, or province. Training is recommended to provide a practical, hands-on capability and an understanding of the behavioral aspects of Nitrous Oxide Sedation and will complement the safety features of this device.

USE SCAVENGING

Monitor for N₂O in the operatory to insure that controls are effective in achieving low levels of ppm (parts per million) exposure. Contact your Porter dealer for details on monitors and testing.

GAS SUPPLY CONNECTION

After installation of the flowmeter, connect the nitrous oxide and oxide supply lines to the Diameter Indexed Safety System (DISS) fittings located on the back of the flowmeter unit. It is important that the regulators for both gases be set to give pressures in the range of 50 PSIG ±2 PSIG.

Confirm the absence of leaks at pressure connections on the unit. Bubbles will appear at leaking locations when a soap / water solution is used. This procedure is recommended each time a cylinder is changed.

MONTHLY LEAK CHECK (or if connections to flowmeter are disconnected and then reconnected, such as after a flowmeter service at the factory or if the DISS/DISS hose is replaced): Leak test the flowmeter system for working pressure leaks. After all hose connections are tightened, turn the flow control knobs to the off position and the on/off switch to the off position. Confirm that the DISS Shut-Off Valves are in the open position. Pressurize the sedation gas supply lines with 50 PSI. Observe any pressure decay after an overnight time period (5 PSI drop allowed).

Monitor O₂ gas pressures at the beginning of each procedure to assure sufficient gas remains in the tank to complete the procedure.

FLOWMETER MOUNTING OPTIONS

The Dental Flowmeter may be mounted to a telescoping wall mount using the existing hanger on the back of the flowmeter, or to a mobile stand using the threaded hole at the bottom of the failsafe block. There are various options for mounting the flowmeter within cabinets. The location selected for mounting of the slide assembly should provide easy access to reach and unobstructed view of the flowmeter when mounted on the slide assembly. There should be adequate space at the rear of the flowmeter for O₂ and N₂O gas delivery hoses. Contact your local dental dealer for mounting options.

Solid Wall Mount – Telescoping Model 2020:

1. Remove cap from the mounting post assembly.
2. Insert mounting post through mounting bracket on back of flowmeter.
3. Replace cap on top of mounting post.
 - a. Position small diameter cap down to allow for swivel mounting (Figure A).
 - b. Position small diameter cap up to fix direction of flowmeter (Figure B).
4. Tighten screw securely.

Figure A

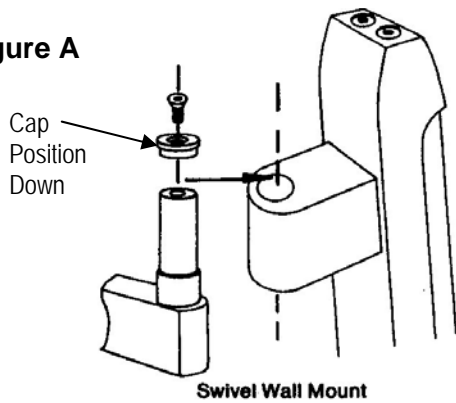
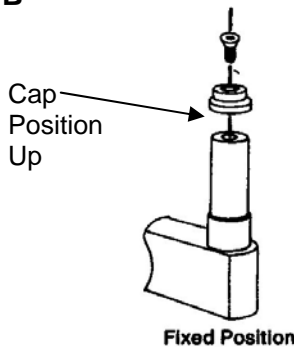

Figure B



Mobile Stand

1. Loosen thumb-screw knob.

Cabinet Mount Slide Model 2036: Figure C

1. Loosen knob on side of mounting block.
2. Remove mounting post from block.
3. Insert post through mounting bracket on back of flowmeter.
4. Replace post with flowmeter attached into mounting block.
5. Tighten knob on side of mounting block.

Figure C

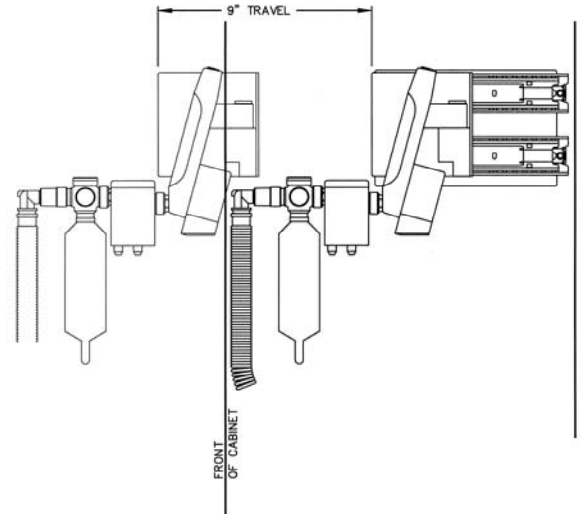

Slide Away Mount Model 2035-1: For ease of accomplishing the dual sliding motion, hold the meter toward the top half and lift slightly while sliding the arm in and out. This will reduce the load on the slide and promote a smoother action. Figure D

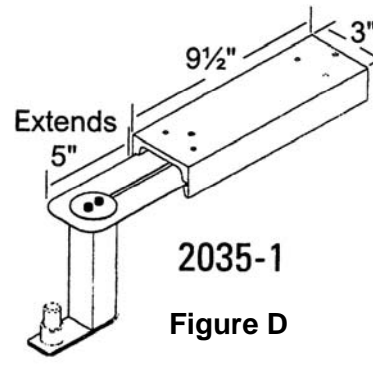

2. Slide shaft up.

3. Insert flowmeter hole in bottom of black failsafe block onto top of mobile stand pole. Figure E
4. While holding the flowmeter still, screw shaft into bottom of the flowmeter.
5. To telescope meter, loosen thumb-screw knob on side of mobile stand, position flowmeter then retighten knob.

Figure E

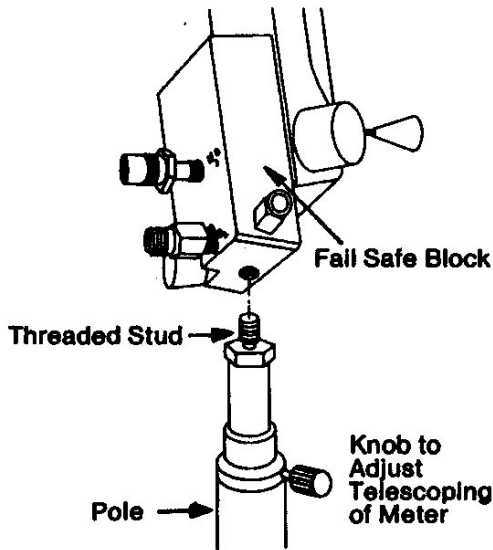

Mobile "E" Stand – Figure F

Refer to installation and instructions FM-916 for mounting flowmeter to Mobile "E" Tank Stand.

Figure F

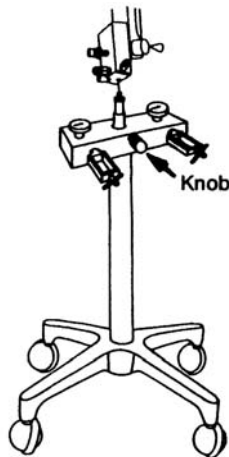

MXR FLUSHMOUNT FLOWMETER

Flowmeter Models 2065W, 3065W and 2070W have Universal connectors that are easily switched in the field from back to bottom or bottom to back position to suit the installation. If the connectors are switched, the flowmeter should be completely function tested after installation to the user instructions contained in this manual.

CAUTION: The position of the connectors may be switched by an authorized Porter representative only. Unauthorized repair, alteration or misuse of this device is likely to adversely affect the performance and will void the warranty.

ORAL SURGERY MXR MODEL 2000-OS

The oral surgery flowmeter can achieve 20 LPM N₂O maximum flow. This model includes a special P2407A oral surgery threaded bag tee with adapter. Accessory includes a Directional "Y" Valve that attaches to the threaded bag tee. (Refer to FM-631 for Directional "Y" Valve Instructions.)

FLOWMETER ACCESSORIES

Three Liter Bag

Install the 3 L Reservoir Bag by sliding the opening over the outside of the bag tee downspout. The bag moves in and out with each inhalation and exhalation and becomes a visual barometer for monitoring the patient's respiration rate. Refer to FM-809 for User Instructions, Assembly, Installation and Cleaning.

Positive Pressure / Demand Valve

The Porter flowmeter is equipped with a Resuscitator Quick Connect, which allows for the attachment of an oxygen demand valve. The Demand Valve Resuscitator provides a fast, simple and effective means to ventilate non-breathing patients and provide 100% oxygen on demand. The Resuscitator Flow rate is limited up to 40 LPM in line with the 1992 American Heart Association "Recommendations and Guidelines for Resuscitation." Refer to the User Instructions supplied with this product for complete details.

Gas Scavenger Breathing Circuit

Gas scavenger system is used to remove exhaled gases during a dental analgesia conscious sedation procedure in a dental operator. The breathing circuit consists of a 22mm 90° elbow connector, fresh gas / coaxial tubing, a corrugated hose and hood assembly. Attach the nasal inhaler to the coaxial tubing assembly using the diameter-indexed connectors. Attach one end of the fresh gas corrugated tubing to the coaxial tubing assembly at the fresh gas “Y” connector and the other end to the 22mm right angle adapter. Press fit the 22mm right angle adapter onto the bag tee. Attach the 3L bag to the bottom / downspout of the bag tee. Attach the vacuum hoses to the vacuum control source (AVS or In-line Vacuum Control Block). Refer to FM-809 for User Instructions, Assembly, Installation and Cleaning.

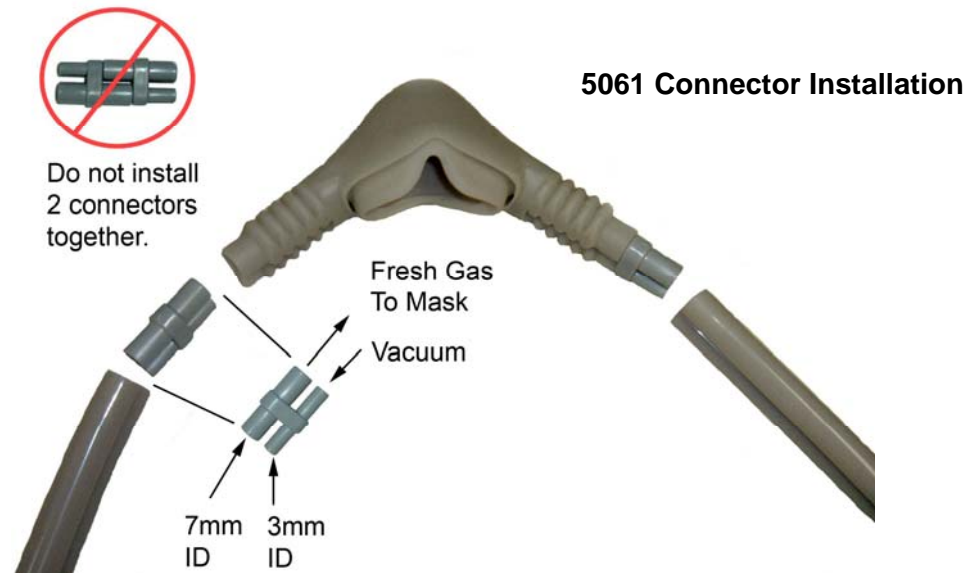

Automatic Vacuum Switch [AVS] (Option)

The AVS is used to control the vacuum flow in the gas scavenger breathing circuit and assure that the scavenging system is activated as soon as N₂O / O₂ is turned ON. Adjust the vacuum flow using the control knob. Vacuum flow is most effective when the ball float is set within the green bar area. Installation of AVS to Flowmeter: Screw AVS 5000 knurled seal nut down tight onto flowmeter making sure the rubber washer is inside the seal nut. When tight, the AVS should not rotate. Then, screw the bag tee seal nut onto the AVS. Bag tee should not rotate. Connecting AVS to Vacuum Hoses: Attach one end of the vacuum hose to the vacuum hose “Y” connector and the other end to the MASK port of the AVS. Attach a second vacuum hose to the VAC port of the AVS and the other end to the vacuum source.

Porter recommends that effective scavenging can be achieved with the ball float in the green bar area of the acrylic sight glass, however NIOSH publications conclude that higher vacuum flows of up to 45 L/min are most effective. To meet the NIOSH recommendation of 45 L/min adjust the ball above the green bar area.

In-line Vacuum Control Kit (Option)

The kit includes a vacuum control block with sight glass, vacuum tube holder, adapter “T” and straight fitting. The vacuum control block can be inserted directly into the High Volume Evacuation (HVE) line or may be placed “in-line” by cutting the vacuum hose and attaching the cut ends of the tubing to both ends of the vacuum control block. Adjust the vacuum flow using the control knob. Vacuum flow is most effective when the ball float is set within the green bar area. Refer to FM-809 for User Instructions, Assembly, Installation and Cleaning.

FIGURE 1

FLOWMETER FEATURES

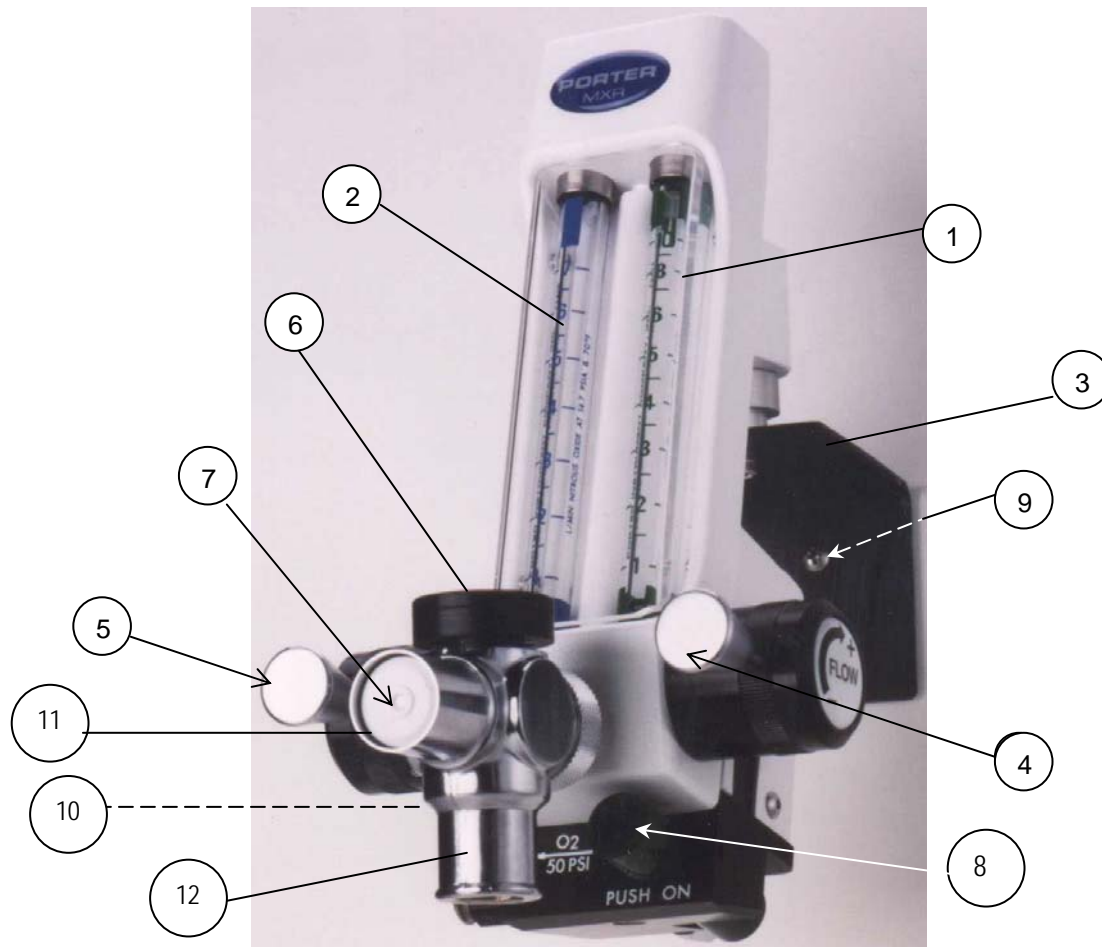

1. **Oxygen Flowmeter Tube** indicates the flow of O₂ in L/min \pm 5%.

2. **Nitrous Oxide Flowmeter Tube** indicates flow of N₂O in L/min \pm 5%.

3. **Nitrous Oxide Failsafe System.** Dual-seal oxygen-piloted valve system that automatically maintains the % N₂O concentration setting with any change in the O₂ flow or pressure. N₂O flow is proportionately reduced if O₂ is shut off or the pressure is reduced (check before each use).

4. **Flow Control Knob** controls the combined flow of O₂ and N₂O (or O₂ flow only when the Concentration Control Knob is set to 0%).

5. **Concentration Control Knob** controls the % concentration of N₂O but does not change the O₂ flow rate. (70% Maximum N₂O delivery.) (Check Monthly)

6. **Emergency Air Valve** automatically provides the patient with ambient air if gas flow is interrupted. (Check Monthly)

7. **Non-Rebreathing Valve** guards against CO₂ build-up and rebreathing of used gases. (Check Monthly)

8. **Positive On - Off Switch** Reduces the possibility of accidentally leaving the machine ON.

9. **Power Flush** provides extra delivery of O₂ to the breathing bag. (Check Monthly)

10. **O₂ Quick Connect** (left side of machine), facilitates connection of positive pressure/ demand valve for emergency Oxygen.

11. **Bag Tee Outlet** connects to fresh gas tubing.

12. **3 L Bag Connection**

SAFETY FEATURE CHECKS

IMPORTANT: These are safety features, which you should routinely check to assure proper function. If any of these safety features are not functioning properly, contact your Dental Dealer or Porter Instrument and arrange for the necessary repairs. Porter Instrument recommends the repairs be made before reusing the device.

NITROUS OXIDE FAILSAFE SYSTEM CHECK BEFORE EACH USE

1. Set the right-hand total Flow Control Knob to zero and set the left-hand Concentration Control Knob to zero. (See Figure 1-Items 4 and 5: Rotate control knobs to stop.)
2. Be sure O₂ and N₂O are connected to your MXR and line pressure for both gases is 50 PSIG (which is standard).
3. Turn the Concentration Control Knob to 50%. **There should be no flow of N₂O.** This is a check of the static position of the Nitrous Oxide Failsafe System valve.
NOTE: A momentary low flow of N₂O (about 1 L/min for about a second) may be seen if the Concentration Control Knob is turned to zero before turning the Flow Control Knob to zero. This is N₂O gas trapped between the Nitrous Oxide Failsafe System valve and the Concentration Control Knob valve and is a normal occurrence. **No other N₂O flow should be observed.**
4. With the Concentration Control Knob still set to 50%, turn the Flow Control Knob to achieve a flow of 3 to 4 L/min of O₂. You should observe an equal amount of N₂O flowing by gradually turning the Flow Control Knob. (Refer to Monthly Calibration Check on Page 13, to read ball float on flowmeter tubes.)

5. Interrupt the flow of O₂. This will check the dynamic status of the Nitrous Oxide Failsafe System valve. This can be done by either disconnecting the oxygen hose from the wall or shutting off the oxygen at the tank. **The Nitrous Oxide flow should drop as the Oxygen flow decreases, stopping completely before the Oxygen float drops to zero.**

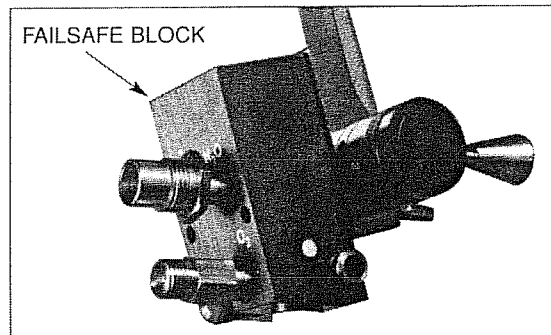

WARNING

If the Nitrous Oxide Failsafe System fails to perform as indicated, do not use this product prior to repair. Improper function of this safety feature may permit Nitrous Oxide to flow independently of the flow control knob, potentially allowing Nitrous Oxide to flow to the patient without Oxygen.

CONCENTRATION CONTROL KNOB VALVE – CHECK MONTHLY

Set the Concentration Control Knob to 50%, and Flow Control Knob to 2 to 3 L/min. The ball indicators will be at about the same height (If not, refer to **Monthly Calibration Check** section on Page 13 for the procedure on checking the accuracy of the meter.). Turn the Concentration Control Knob to zero. The N₂O flow should drop to zero. You essentially perform the check at the end of every procedure when you oxygenate the patient with 100% O₂.

**POWER OXYGEN FLUSH
CHECK MONTHLY
(O₂ SUPPLY PRESSURE AT 50 PSIG)**

Disconnect the corrugated rubber tubing from the bag tee outlet (Figure 1, Item 11). With both control knob valves OFF, depress the power (O₂) flush button while blocking the flow from the front of the bag tee. For proper operation, the gas reservoir bag should fill within about 5 seconds. Also test for bag / rubber goods leak following steps 1 through 6.



Quick Test to Check 3 Liter Bag / Rubber Goods for Leaks

1. With the flowmeter, bag tee and **Porter** rubber goods in place, remove the nosepiece and one of the two plastic connectors from the Porter rubber goods. Refer to Figure 2.

2. With the other plastic connector, join the two duplex hoses together making a closed system.
3. Taking care not to fill the bag too much (bag could burst), open the oxygen control valve until the 3 liter bag starts to over-inflate or “balloon”, then close the valve.
4. Observe the 3 liter bag for five minutes.
5. The bag should stay inflated. If so, the test has been successful and there are no excessive leaks. If the bag does not stay inflated, the 3-liter bag or rubber goods have an excessive leak. Replace any parts that leak and retest until results are successful.
6. Disconnect one of the duplex hoses from the plastic connector and re-install the nosepiece.

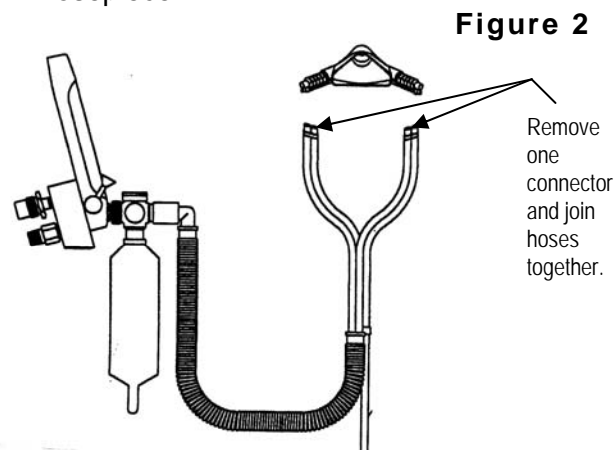

BAG TEE

The Bag Tee assembly features a Non-rebreathing Valve and an Emergency Air Intake located on the Bag Tee, which comply with American Dental Association guidelines. The non-rebreathing valve has a back flow check valve, which prevents exhaled gases from entering the breathing bag (no carbon dioxide buildup). The emergency air intake has a valve that allows room air to be inhaled into the breathing circuit by the patient. A breathing bag is attached to the metal portion of the Bag Tee and is a reservoir bag for the delivered analgesia gases, which when taken together with the two valves above, becomes the visual barometer for monitoring the patient’s respiration rate. The bag moves in and out with each inhalation and exhalation.

Bag Tee Installation to Flowmeter: Screw knurled seal down tight onto flowmeter

making sure the rubber washer is inside the seal nut. When tight, the bag tee should not rotate.

NOTE: Fit mask to patient so inner mask is pulled down tight secure to the face. Outer mask should not be against the face. Vacuum needs to be drawn into outer mask during inhalation.

NON-REBREATHING VALVE CHECK MONTHLY

With unit turned OFF, disconnect the corrugated rubber tubing from the Rubber Goods and breathe into the corrugated tubing connected to the bag tee. You should not be able to fill the bag with exhalation gas. If the bag fills, the system's Non-Rebreathing Valve is not functioning properly and should be replaced.

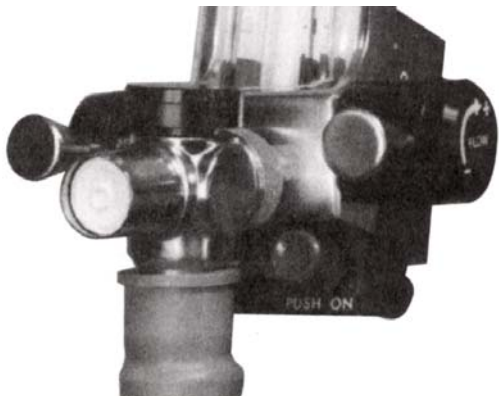

EMERGENCY AIR VALVE CHECK MONTHLY

With unit turned OFF, disconnect the corrugated rubber tubing from the Rubber Goods and draw air with your mouth through the corrugated tubing connected to the bag tee. You should be able to draw ambient air through the Emergency Air Valve (the gas bag may have to fully collapse first). Air going through the valve sounds different than normal gas flow.

MONTHLY CALIBRATION CHECK

The MXR Flowmeter is designed to maintain its accuracy and performance without routine user maintenance being required. The

flowmeter tubes and ball floats are very resistant to accuracy changes over time such that the direct readings of the L/min on the scales maintain their accuracy. However, the user can check the relative accuracies of the % concentration and total flow valve system by performing a simple check.

A calibration check of the % concentration can be done by setting the % concentration knob to 50% and the flow control knob to 3 to 4 L/min. Check to see if the tube readings are within 0.5 L/min of each other. Servicing is indicated if the readings are out of this tolerance.

NOTE: Adequate and safe conscious sedation can be achieved even if the % concentration is outside of the listed tolerance, since tube scale accuracies are maintained. However, a change in the % concentration calibration is an indication of overall flowmeter condition. Porter servicing is available, including recalibration, pressure testing, internal component checking and replacement, and final factory testing by contacting your Authorized Porter Dental Dealer. It is advisable, on a two (2) year cycle, to have the MXR Flowmeter factory checked and serviced.

Figure 3

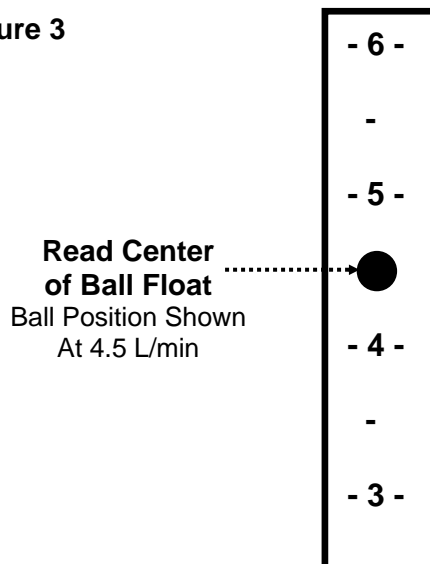

DIRECTIONS FOR USE

NOTE: These directions detail a basic delivery technique. *However, this is not a comprehensive description and not a substitute for a training course that emphasizes a practical, hands-on approach together with instruction on safe administration techniques.* Topics covered in such a course will include experiences of practitioners in specific dental clinical settings, the pharmacokinetic properties of nitrous oxide, strategies to avoid over sedation and allow for biological variability, and strategies to maximize patient satisfaction.

1. Maintain patient observation during procedure.
2. Turn ON unit by pushing in the ON / OFF switch.
3. Open N₂O / O₂ tank valves.
4. Using Flow Control knob, set flow rate of O₂ to desired rate, keep bag about $\frac{3}{4}$'s full. Rotate flow control knob upwards (clockwise) to increase flow. (See Figure 1, Item 4)

Flow Control Knob

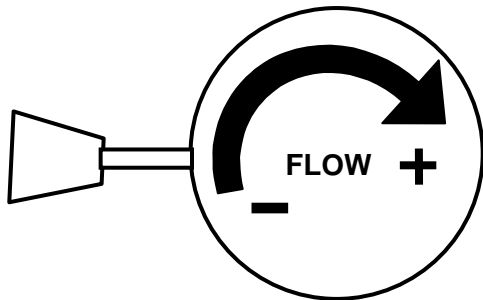

5. Set N₂O concentration to desired level by rotating Concentration Control Knob (See Figure 1-Item 5) upwards (counterclockwise) to increase concentration, as read by percentages inscribed on the control knob. Rotate slowly until desired level is achieved. Practice titration* with 10% nitrous upward movements every 60 seconds until endpoint achieved. Patients may typically experience relief of anxiety, tingling in extremities, and euphoria. Patients typically require less than 50% nitrous.

Concentration Control Knob

Setting shown at 60%

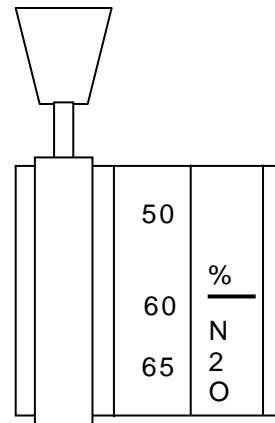

6. Flow Control knob may be re-adjusted to bring the total flow of gases back to desired level, when concentration is increased or decreased. Total flow is equal to the sum of right and left tube readings. (See Figure 3, to read ball float on flowmeter tube.)
7. When the procedure is nearing completion, amounts of N₂O should be decreased. Terminate the flow of N₂O and deliver 100% O₂ to begin a minimum post-oxygenation period of 3 to 5 minutes. Assess the patient for appropriate recovery. Administer additional O₂ if necessary. Titration and post-procedure 100% O₂ will minimize nitrous exposure to the operator, potential patient side effects of lethargy, headache, or nausea, and any potential adverse effects of nitrous diffusion into air filled cavities.
8. When procedure is finally completed, turn off **both** control knob valves for gas shut off.
9. Place the ON / OFF switch (primary shut-off mechanism) in the OFF position. (Push from back of ON / OFF switch.) **NOTE:** If control valves are still open, gas flows should stop at this point.
10. Turn OFF the gas supply at the tank at the end of the day.

***NOTE:** Refer to "Basic Delivery Technique" on the following page.

***BASIC DELIVERY TECHNIQUE:**

“Practice titration. Titration is a method of administering a substance by adding definitive amounts of a drug until an endpoint is reached. For nitrous oxide / oxygen (N₂O) / O₂) sedation, N₂O is given in incremental doses until a patient has reached a comfortable relaxed state of sedation. The ability to titrate N₂O is a significant advantage because it limits the amount of drug to that which is required by the patient. If titration is done properly, the patient does not receive any more of the drug than is necessary. The amount of N₂O required by a patient on any given day or time varies.”¹

For information on titration, a most valuable resource for the practitioner is the Handbook of Nitrous Oxide and Oxygen Sedation, written by Clark and Brunswick and published by Mosby (www.mosby.com). This text is a concise and contemporary guide for nitrous oxide / oxygen administration.

IMPORTANT NOTE:

When the Concentration Control knob is open, the Flow Control knob is closed, and there is no N₂O flow indicated in the flow tube, the Nitrous Oxide Failsafe System will stop the flow of N₂O. However, this safety feature should not be used as the primary shut off mechanism. The control knobs are for primary shut-off.

NOTE: If your unit does not operate as described in Steps 1 through 10, please contact your Dental Dealer or Porter Instrument.

MAINTENANCE AND SERVICE

It is advisable, on a two (2) year cycle, to have the MXR Flowmeter factory checked and serviced. The Nitrous Oxide Failsafe System is made of moving parts. Between servicing intervals, it is advisable to safeguard against potential malfunctions by performing the failsafe check before each and every use of the unit. Safe operating techniques, learned during your N₂O - O₂ Conscious Sedation training, should always be used.

Inspect and maintain the analgesia delivery system to prevent N₂O leaks in all hoses, connections and fittings. Repair all leaks immediately.

CLEANING METHODS

We recommend the use of an approved disinfectant for the dental environment for cleaning the outside of the flowmeter and accessories. Do not spray disinfectant directly onto meter. Spray disinfectant into disposable towel and wipe unit thoroughly removing excess disinfectant to eliminate buildup.

Control knobs can be autoclaved. Remove knobs from flowmeter. Clean using an appropriate disinfectant. Rinse with water then autoclave. Do not exceed 275°F for 15 minutes maximum.

¹Handbook of Nitrous Oxide and Oxygen Sedation – Morris Clark • Ann Brunick

TROUBLESHOOTING CHART FOR MXR FLOWMETERS

SYMPTOM	POSSIBLE CAUSE	REMEDY
No flow of O ₂ or N ₂ O when ON /OFF switch is ON and left knob is set at a concentration of N ₂ O or O ₂ the right knob is rotated to give flow.	<ol style="list-style-type: none"> 1. O₂ supply not turned ON. 2. Machine not connected to pipeline system. 3. Empty O₂ cylinders. 	<ol style="list-style-type: none"> 1. Turn O₂ regulator in tank room ON. 2. Connect to wall outlet. 3. Replace with full cylinder.
Can get O ₂ flow but cannot get N ₂ O flow.	<ol style="list-style-type: none"> 1. N₂O supply not turned ON. 2. N₂O cylinder empty. 	<ol style="list-style-type: none"> 1. Turn ON N₂O cylinder. 2. Replace with full cylinder.
With N ₂ O concentration set, both flows vary proportionally with no change in flow setting.	O ₂ regulator is varying pipeline pressure.	Check O ₂ regulator. Be sure O ₂ manifold pressure is 50 PSIG ±2 PSIG. If not, call Dealer for service.
Meter will flow N ₂ O without any O ₂ flow in the O ₂ tube.	Failsafe failure.	Take out of service and return to Porter.
Cannot get 9 ½ L/min O ₂ flow with concentration control knob OFF and flow control knob full ON.	Low O ₂ pressure setting.	Check O ₂ regulator. Be sure O ₂ manifold pressure is 50 PSIG ±2 PSIG. If not, call Dealer for service.
Ballooning of the gas bag.	90° Elbow connected onto bag tee is pushed on too far, blocking movement of the non-rebreathing valve.	Remove rubber goods and 90° elbow from bag tee. Reconnect elbow and rubber goods.
Gas is leaking from the ON/OFF switch.	Nick or cut in o'rings on the ON/OFF switch.	Call Dealer for service.
Patient not feeling effects of gases.	<ol style="list-style-type: none"> 1. Outer mask is not fit properly to patient's face. 2. Gas flows do not meet patient's requirement. 	<ol style="list-style-type: none"> 1. Fit so inner mask is secure to face but outer mask is just off face. 2. Re-adjust gas flows to obtain acceptable bag action.
Bag is going flat during procedure.	<ol style="list-style-type: none"> 1. Gas flows do not meet patient's requirement. 2. Outer mask is not fit properly to patient's face. 	<ol style="list-style-type: none"> 1. Re-adjust gas flows to obtain acceptable bag action. 2. Fit so inner mask is secure to face but outer mask is just off face.

CERTIFICATE OF WARRANTY

THIS WARRANTY IS GIVEN IN PLACE OF ALL OTHER WARRANTIES, EXPRESS OR IMPLIED, OF MERCHANTABILITY, FITNESS FOR A PARTICULAR PURPOSE OR OTHERWISE.

Under no circumstances shall Parker Hannifin Corporation be liable for incidental or consequential damages as those terms are defined in the uniform commercial code.

Parker Hannifin Corporation, Porter Instrument Division warrants that each product or part shall be free from defects in workmanship and materials, under normal use and with appropriate maintenance, for one (1) year from the date of delivery to customer unless otherwise specified in writing. All rubber and plastic parts and accessories are warranted under the same conditions for a period of ninety (90) days from date of purchase.

No statement or claim about the product by any employee, agent, representative, or dealer of Parker Hannifin Corporation shall constitute a warranty by Parker Hannifin Corporation or give to rise to any liability or obligation of Parker Hannifin Corporation.

Parker Hannifin Corporation shall not be liable for any damage, injury or loss arising out of the use of the product, whether as a result of a defect in the product or otherwise, if, prior to such damage, injury or loss, the product was (1) damaged or misused; (2) repaired, altered or modified by persons other than Parker Hannifin Corporation; (3) not installed in strict compliance with applicable codes and ordinances; or (4) not installed by an authorized Parker Hannifin Corporation dealer. Parker Hannifin Corporation's obligation for breach of this warranty, or for negligence or otherwise, shall be strictly and exclusively limited to the repair or replacement of the product or part. This warranty shall be void on any product on which the serial number has been altered, defaced or removed.

ORDERS All orders are to be made through authorized Parker Hannifin Corporation distributors. All billing will be done through said distributors. Direct orders will be handled through the authorized local dealer as determined by Parker Hannifin Corporation.

RETURNS All returned merchandise will be handled through the local Parker Hannifin Corporation distributor. No returns will be accepted unless authorized in writing by Parker Hannifin Corporation and accompanied by the original shipping invoice. All returns are subject to restocking charge.

Policies subject to change without notice.



The ADA Council on Scientific Affairs' Acceptance of Porter Conscious Sedation Flowmeter MXR 3000 is based on its findings that the product is effective for use in delivering nitrous oxide – oxygen conscious sedation in the dental operatory.

The Quality System for Porter Instrument is Certified to ISO 13485. The scope of our registration is: "The design, manufacture, distribution and servicing of Dental Flowmeters, Gas Scavenging Systems, Gas Distribution Systems and Office Communication Systems for use in the Dental Profession."

FM-286 Rev. Q 10/06