

Owner's Guide



CASCADE[®] 1040 Chair

Warranty Information	
Serial Number	_____
Model Number	_____
Date Purchased	_____

Date of Service	Model/Description of Service	Technician's Initials

ALPHABETICAL EQUIVALENT TO THE NUMERAL OF THE MONTH MANUFACTURED

A	January
B	February
C	March
D	April
E	May
F	June
G	July
H	August
I	September
J	October
K	November
L	December

**2601 CRESTVIEW DRIVE
NEWBERG, OREGON 97132 USA**

Designated ED Representative: A-dec Dental U.K., Ltd.
Austin House, 11 Liberty Way, Attleborough Fields,
Nuneaton, Warwickshire, England CV116RZ
Tele: (44) 24 7635 0901

SN: J828287 **REF: 2122**

MADE IN USA
1999

SERIAL NUMBER
MODEL NUMBER
YEAR MANUFACTURED

Serial Number Identification

Cascade Chair Serial Number Location:

- On the upper structure, under the upholstery

For service information contact your local authorized A-dec dealer.

Check with local codes and A.D.A. (Americans with Disabilities Act) Requirements for Installation of this product.

A-dec warrants all products in this catalog against defects in material or workmanship for one year from time of delivery. A-dec's sole obligation under the warranty is to provide parts for the repair, or at its option, to provide the replacement product (excluding labor). The buyer shall have no other remedy. All special, incidental, and coincidental damages are excluded.

Written notice of breach of warranty must be given to A-dec within the warranty period. The warranty does not cover damage resulting from improper installation or maintenance, accident or misuse. The warranty does not cover damage resulting from the use of cleaning, disinfecting or sterilization chemicals and processes. The warranty also does not cover light bulbs. Failure to follow instructions provided in the A-dec owner's guide (operation and maintenance instructions) may void the warranty.

A-dec warrants A-dec dental chair cylinders, both lift and tilt, for ten years from the date of purchase of the chair or the cylinder. This warranty is retroactive to A-dec chair cylinders already in the field. The warranty covers chair cylinders A-dec finds to have manufacturing related irregularities. Stool cylinders are covered under A-dec's one-year warranty.

**No other warranties as to merchantability
or otherwise are made.**



All product names used in this document are trademarks or registered trademarks of their respective holders.

Cascade 1040 Chair

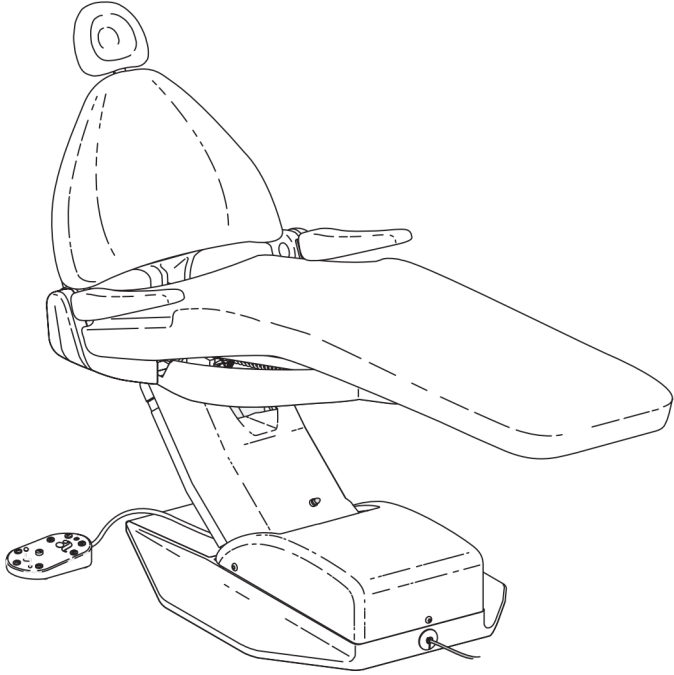

Cascade 1040 Chair

CONTENTS

Serial number location, service information, and warranty information are located on the inside front cover and front page.

About Your Cascade Chair	2
Chair LED.....	2
Chair Stop Plate	2
8-Function Footswitch	3
Touch Pad	3
Programming the Chair	5
Swivel Brake	8
Double-Articulating Headrest	9
Headrest Positioning for Wheelchair	10
Headrest Drift Adjustment	11
Upholstery Replacement	12
Back Upholstery	12
Double-Articulating	
Headrest Upholstery	13
Seat Upholstery	14
Armrest Upholstery	15
Care Instructions	16
Adjustments and Specifications	17
Maintenance	17
Safety Considerations for	
Accessory Equipment	18
Transporting the Dental Unit	18
Identification of Symbols	19
Classification of Equipment (EN 60601-1)	19

About Your Cascade Chair

Your Cascade chair is an electronically controlled, hydraulically powered dental chair (see Figure 1).

Chair functions are controlled by the 8-function footswitch or touch pad (see Figure 2 or 2a on page 3).

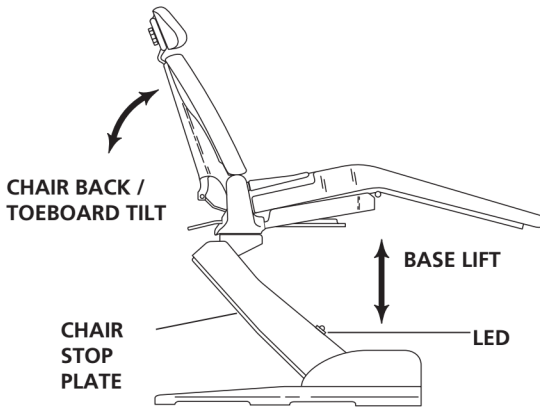

Figure 1. Lift, Tilt, and Stop Plate

Chair LED

The chair LED indicates the status of the chair:

ON: Normal operation.

SLOW BLINK: The cuspidor or stop plate limit switches have been activated. Remove any obstructing object.

Chair Stop Plate

The chair stop plate (see Figure 1) stops the chair immediately when any part of it is pressed. Should anything inadvertently become lodged under the chair, press Base UP on the footswitch or touch pad to raise the chair so the object can be removed. As long as pressure is applied to the stop plate, the chair base will not go down any further.

8-Function Footswitch

The 8-function footswitch (see Figure 2) or the chair touch pad (see Figure 2a) gives you both manual and programmed control of chair positioning. The arrows on the footswitch and touch pad manually control chair back/toeboard tilt and chair lift. The numbered buttons are for Entry/ Exit and programmed chair positions.

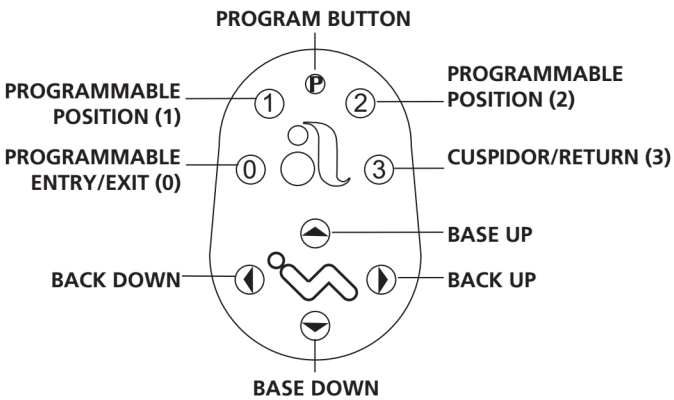

Figure 2. 8-Function Footswitch

Touch Pad

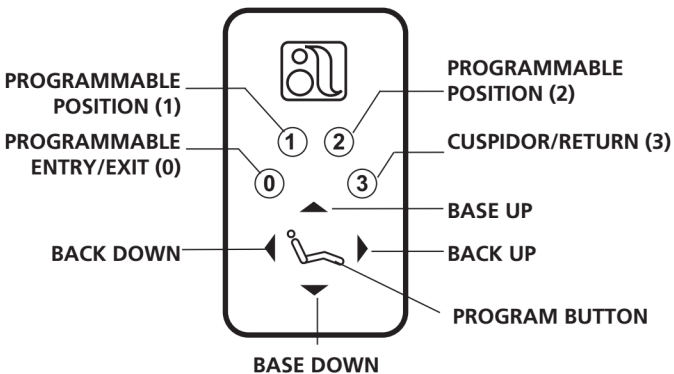

Figure 2a. Chair Touch Pad

Manual Controls

The **Base Up/Down (lift)** function controls chair lift, or vertical movement. To raise the chair, push the up arrow on the footswitch or touch pad. To lower the chair, push the down button on the footswitch or touch pad. Push the button until the chair reaches the desired height, then release it.

The **Back Up/Down (tilt)** function controls the chair back/toeboard tilt. To raise the chair back, push the right arrow on the footswitch or touch pad. To lower the chair back, push the left arrow on the footswitch or touch pad. Push the button until the chair back reaches the desired position, then release it.

Program Button

The Program Button (located on the top middle of the footswitch, or in between the arrows on the touch pad) is used to save the settings for Entry/ Exit (0), programmable positions (1 and 2), and Cuspidor/Return (3).

Programming the Chair

Programmable Positions 1 and 2

NOTE

When 1 or 2 are pressed on the footswitch or touch pad, the chair base and back go to the preset position.

To stop the chair at any point, press any button on the footswitch (or press any button on the touch pad).

To send the chair to a programmed operating position, push either 1 or 2 (or press 1 or 2 on the touch pad). Positions 1 and 2 are programmed at the factory to move the chair to the same position.

To change a programmable position, locate the program button on the footswitch or touch pad (see Figures 2 or 2a on page 4).

1. Using the manual arrows on the footswitch or touch pad, set the chair to the operating position that you prefer.
2. Press and release the program button. An audible tone will be emitted. Then, **within four seconds**, push the button for 1 or 2 to store that position. You will hear an audible tone confirming that the programmable function has been reprogrammed.
3. Check the programmed position by manually moving the chair to another position. Then push either 1 or 2 programmed in Step 2. The chair should move automatically to the position set in Step 1.

Optional Program Functions

Position 3 is factory set in the **Cuspidor/Return** mode. In this mode, the chair back will rise to a pre-programmed upright position providing the patient access to the cuspidor. Pressing position 3 a second time lowers the chair back to its previous operating position.

Position 3 may also be used as a third Pre-Position or as a last recall.

Contact an authorized A-dec Dealer to have Position 3 reconfigured to a third Pre-Position or as a last position recall.

Entry/ Exit (0)

To send the chair to a preset entry/exit position, push the position 0 button (see Figure 2 or 2a on page 3).

NOTE

When pushed, Entry/ Exit (0) will cause the chair base and back to go to the preset entry/exit position.

To stop the chair at any point, push any button on the footswitch or touch pad.

If you want to change the preset entry/exit position, first locate the program button on the footswitch or touch pad (see Figure 2 or 2a on page 3).

1. Using the manual arrows, set the chair to the desired patient entry/exit position.
2. Press and release the program button. An audible tone will be emitted. Then, **within four seconds**, press the Entry/Exit (0) button on the footswitch or touch pad. You will hear an audible tone confirming that the chair has been reprogrammed. This stores your preferred patient entry/exit position.
3. Check the Entry/ Exit (0) function by manually moving the chair to another position. Push the Entry/ Exit (0) button. The chair should move automatically to the position you set in Step 1.

Swivel Brake

When engaged, the chair swivel brake restricts rotation of the chair. With the brake released, you can rotate the chair to any position within approximately 30° either side of center. To unlock the swivel brake, push the brake lever to the right. To lock the swivel brake, push the brake lever to the left.

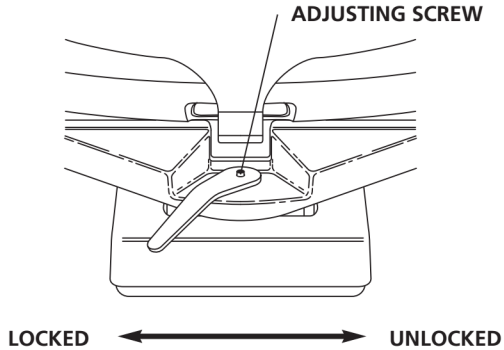

Figure 4. Swivel Brake Adjustment

If the chair swivels left or right with the brake engaged, or if it is difficult to move with the brake disengaged, the swivel brake tension must be adjusted.

Using a 3/16-inch hex key, adjust the swivel brake tension. Turn the adjusting screw clockwise to increase brake friction. Turn the screw counterclockwise to decrease brake friction.

Double-Articulating Headrest

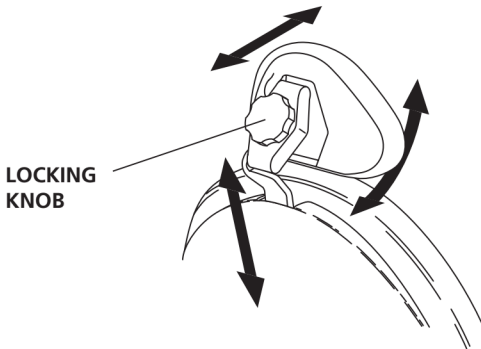

Figure 5. Double-Articulating Headrest

The locking knob allows you to easily adjust the headrest for a full range of positions.

To position the headrest, release the locking knob by turning the knob out (counterclockwise), then adjust the headrest as necessary to fit the head and neck. Lock the headrest in the desired position by turning the knob in (clockwise).

To move the headrest higher or lower, simply pull up or push down on the headrest until it is at the desired height.

Headrest Positioning for Wheelchair

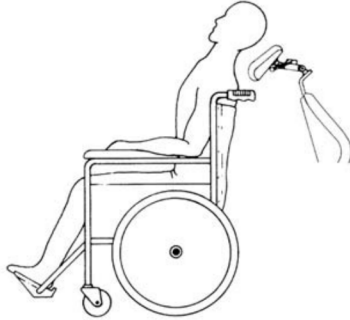

Figure 6. Headrest Positioning for Wheelchair Usage

The headrest can be used to accommodate wheelchair patients. Slide the headrest up until it is free from the chair, turn it 180°, then slide it back into the backrest and push it all the way down. Run the chair to its full Back Up position. Adjust headrest height by moving the chair up or down (using the Base Up function on the footswitch or touch pad), then position the headrest as desired.

Headrest Drift Adjustment

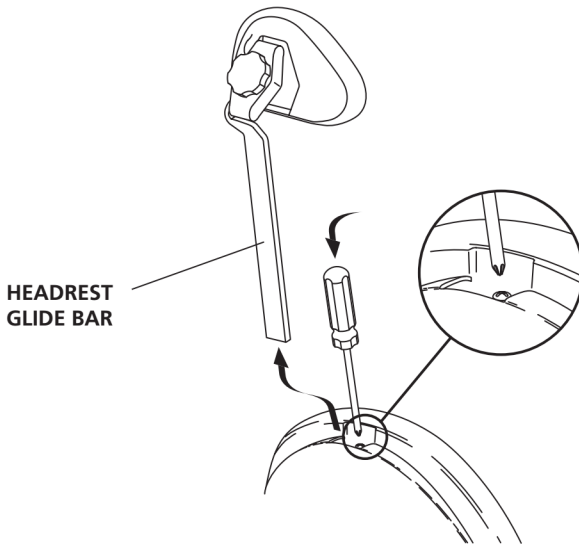

Figure 7. Headrest Drift Adjustment

If the headrest drifts downward, or if it is difficult to move up or down, the glide bar tension must be adjusted. Remove the headrest glide bar to access the adjusting screw.

Using a Phillips screwdriver, adjust the glide bar tension. Turn the adjusting screw clockwise three to four revolutions to increase friction and hold the headrest more securely. Turn the screw counterclockwise three to four revolutions to decrease friction and allow the headrest to move up and down more freely. Reinstall the headrest and recheck glide bar tension.

Upholstery Replacement

A-dec's unique formed upholstery makes replacing upholstery quick and easy.

The upholstery on your Cascade 1040 Chair is installed in four sections: back, headrest, seat, and armrests. Each section is easily removed and replaced.

Back Upholstery

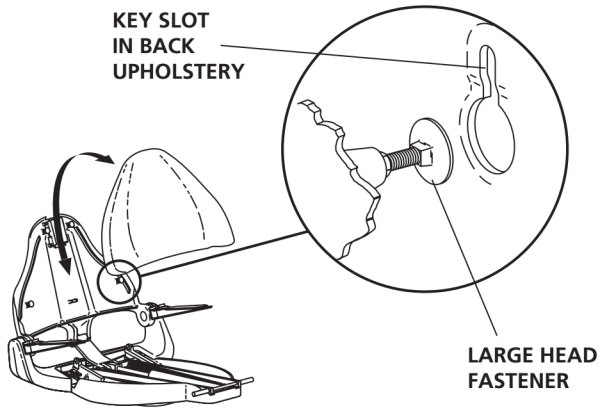

Figure 8. Replacing the Back Upholstery

To remove back upholstery firmly grasp the bottom edge of the cushion and lift upward, approximately 1-inch, to release the four large, flat-headed fasteners from the cushion key-slots.

To install back upholstery place the large fastener heads in the cushion keyhole pockets then push in and down in one motion.

Double-Articulating Headrest Upholstery

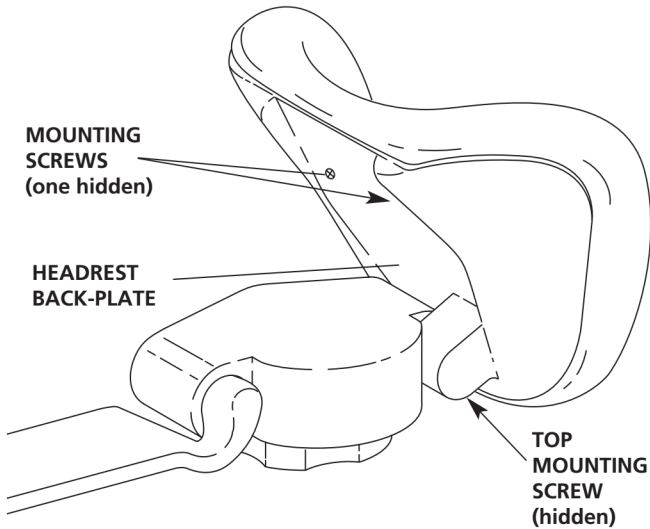

Figure 9. Replacing the Headrest Upholstery

Use the following procedure to replace the headrest upholstery.

1. Loosen the headrest knob and rotate the headrest to a full upright position.
2. Remove the top Phillips mounting screw from the headrest back-plate, located just above the knob assembly.
3. Rotate the headrest back 45° to expose the two Phillips mounting screws on the lower headrest back-plate (see Figure 9). Remove the two screws and the headrest cushion.
4. To attach the replacement upholstery, reverse this procedure.

Seat Upholstery

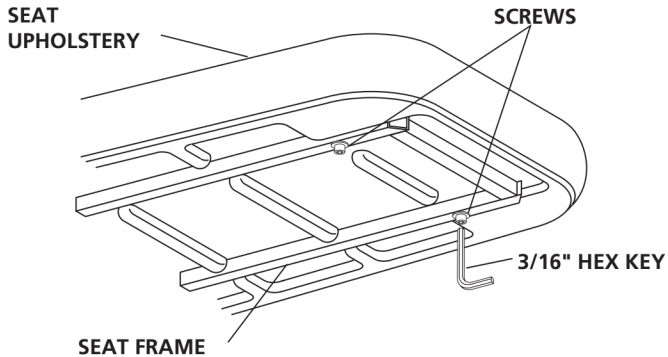

Figure 10. Replacing the Seat Upholstery

Use the following procedure to replace the seat upholstery.

1. Lower the chair back, lift the toeboard, and hold it by the frame.
2. Detach and remove the clear vinyl toeboard cover.
3. Using a 3/16-inch hex key, loosen the four screws that secure the seat/toeboard upholstery assembly to the seat frame.
4. Lower the toeboard and lift off the seat/toeboard upholstery assembly.
5. Place the new seat/toeboard upholstery assembly on the seat frame.
6. Lift the toeboard and tighten the four screws, then lower the toeboard.
7. Attach the new clear vinyl toeboard cover.

Armrest Upholstery

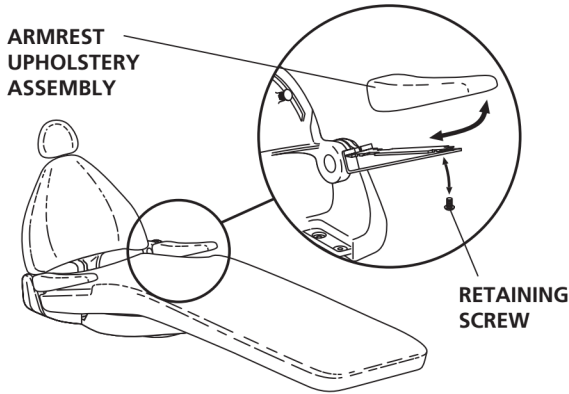

Figure 11. Replacing the Armrest Upholstery

Use the following procedure to replace the armrest upholstery assembly.

1. Lift the armrest away from the seat pocket. Use a Phillips screwdriver and remove the retaining screw from the underside of the armrest.
2. Push the armrest upholstery assembly toward the toe end of the chair, approximately 1/2-inch, then lift the armrest upholstery away from the arm.
3. Place the new armrest on the arm and slide it toward the chair back. Replace the retaining screw on underside.

Care Instructions

For recommended asepsis instructions, refer to the **Asepsis** section of the *Owner's Guide* (A-dec Publication No. 85.0696.00).

Adjustments and Specifications

Programming the Chair page 5
 Swivel Brake page 8
 Double-Articulating Headrest page 9
 Headrest Drift Adjustment page 11

Chair Capacity:

- Patient Load: 300 lbs. (135 kg) maximum.
- Accessory Load: 150 lbs. (67.5 kg) maximum.

Maximum Load from Accessories:

- Chair Adapter: 200 lbs. (90 kg) weight combined with a moment of 250 ft. lbs. (339 N·m)
- Radius Front Mount: 180 lbs. (81 kg) weight combined with a moment of 525 ft. lbs. (711.8 N·m)
- Radius Rear Mount: 70 lbs. (31.5 kg) weight combined with a moment of 160 ft. lbs. (216.9 N·m)

Maintenance

Upholstery Replacement page 12
 Back Upholstery page 12
 Double-Articulating
 Headrest Upholstery page 13
 Seat Upholstery page 14
 Armrest Upholstery page 15
 Care Instructions page 16

Equipment Asepsis Owner's Guide85.0696.00
Maintenance Parts Owner's Guide85.2634.00

Specifications are subject to change without notice.

Safety Considerations for Accessory Equipment

The use of accessory equipment not complying with the equivalent safety requirements of this equipment may lead to a reduced level of safety of the resulting system.

Consideration relating to the use of accessory equipment shall include:











Evidence that Safety Certification of the accessory equipment has been performed in accordance to the appropriate IEC 601 and IEC 601-1 Harmonized National Standards.

Transporting the Dental Unit

When transporting the dental unit the chair base should be fully down, and the chair back should be fully up. The chair body should be secured to the chair baseplate. Do not lift the chair by the chair body.

The delivery system should be over the seat upholstery and the light should be centered above the chair.

The delivery system and light should be secured to prevent movement. The entire Dental Unit should be secured to the transporting vehicle.

Identification of Symbols	
Symbol	Description
	Recognized by Underwriters Laboratories Inc. with respect to electric shock, fire and mechanical hazards only in accordance with UL 60601-1 (2601-1) and under mutual recognition agreement with CAN/CSA C22.2, No. 601.1.
	Classified by Underwriters Laboratories Inc. with respect to electric shock, fire and mechanical hazards only in accordance with UL 60601-1 (2601-1) and under mutual recognition agreement with CAN/CSA C22.2, No. 601.1.
	UL listed to UL 61010A-1, BS EN 61010-2-010 and Canadian (CAN/CSA C22.2, No. 1010.1-92) safety standards.
	Conforms to European Directives (refer to Declaration of Conformity)
	Protective earth (ground).
	Functional earth (ground).
	Attention, consult accompanying documents. No user serviceable parts. Attention, line voltage. Only licensed electrician should remove cover.
	Type B Applied Part.
	Class II equipment.
	Caution: Metal surfaces can be hot during and following the dry cycle.

Classification of Equipment (EN-60601-1)	
Type/Mode	Classification
Type of shock protection	<p>CLASS I EQUIPMENT: Dental chairs, dental lights, and power supplies</p> <p>CLASS II EQUIPMENT: Chair, wall, and cart mounted delivery systems</p>
Degree of shock protection	TYPE B APPLIED PART: Delivery systems only
Degree of protection against water ingress	ORDINARY EQUIPMENT: All products
Mode of operation	<p>CONTINUOUS OPERATION: All models except Dental Chairs</p> <p>CONTINUOUS OPERATION WITH INTERMITTENT LOADING: Dental chairs -</p> <p style="text-align: center;">5% duty cycle</p>
Flammable Gasses	Not suitable for use in the presence of a flammable anesthetic mixture with air, oxygen, or nitrous oxide, where such gasses may accumulate in concentration (closed space).

Electrical Rating	
Type	Specification
Volts	100/110-120/220-240 VAC
Frequency	50-60 Hz
Current	As configured and specified in equipment manual (products labeled 15A or greater require dedicated circuit, identified in distribution panel)
Environmental Specifications	
Temperature /Humidity	Specification
Storage/ Transportation	Temperature: -40°C to 70°C (-40°F to 158°F) Relative Humidity: 95% maximum
Operating	Temperature: 10°C to 40°C (50°F to 104°F) Relative Humidity: 95% maximum
Indoor Use	Altitude up to 2,000m (6, 563 ft.), installation category II, pollution degree 2. (UL 61010A-1 and CAN/CSA C22.2, No. 1010.1-92 only)

USA and Canada

2601 Crestview Drive
Newberg, Oregon 97132 USA
Phone: 1.800.547.1883
1.503.538.7478
Fax: 1.503.538.0276
www.a-dec.com

International

Phone: 1.503.538.9471
Fax: 1.503.538.5911

Distribution Centers

A-dec Australia

41-43 Bowden Street
Alexandria, NSW 2015, Australia
Phone: 61 (0)2 9699 4600
www.adec.com.au

A-dec United Kingdom

Austin House
11 Liberty Way
Nuneaton, Warwickshire
England CV11 6RZ
Phone: 0800 ADECUK (233285) Within UK
44 24 7635 0901 Outside UK
www.a-dec.co.uk