

# ELEC TRACE INDUSTRIAL

DATASHEET

## The Lantern

LIGHTED END SEAL FOR HEAT  
TRACING SYSTEM



# JHE-L-GET HIGH-PROFILE LIGHTED END SEAL

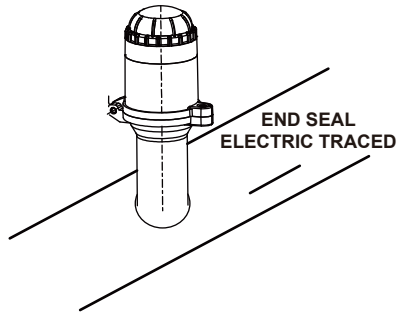
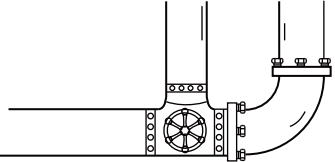

## DESCRIPTION:

The Lantern is an end seal kit with a light that indicates voltage at the end of the circuit. It is designed for use with HTR industrial parallel heating cable.

Once installed, the end seal is easily accessible for maintenance and the heating cable can be accessed without removing the end seal. The LED indicator light provides excellent visibility.

This kit may be installed at temperatures as low as -40°F (-40°C). For easy installation, store above freezing prior to mounting. The kit is rated for 85 to 265 V.

Make sure voltage rating of light is the same as that of the heat-tracing circuit.

## TOOLS REQUIRED:

- Wire cutters
- Utility knife
- Needle nose pliers
- Slotted screwdriver or nutdriver

## ADDITIONAL MATERIALS REQUIRED:

- Pipe strap
- Fiber glass tape

**APPROVAL:**  
 Class I, Div.2, Groups A, B, C, D;  
 Class II, Div.2, Groups E, F, G;  
 Class III; Type 4X, IP65;

## KIT CONTENTS:

Item	Qty.	Description
A	1	End seal stand and light assembly
B	2	Insulated parallel crimps
C	1	End seal label
D	1	Core sealer

