



## HAILO AS Duo 8/8 stainless steel/black

**3416101**

GTIN: 4007126341617

For hinged door cabinets from 450 mm width



SWING



2 BUCKET

**16 L**

TOTAL

Suitable for cabinet width (cm)

45, 50, 60

- May be installed on left or on right sidewall

### Specifications

Type of installation	Swing	✓
Cabinet-width min. (cm)		45
Cabinet-width max. (cm)		60
Suitable for cabinet width (cm)		45, 50, 60
available Cabinet-depth min. (mm)		199
Sidewall mounted		✓
Product dimensions (WxDxH) (mm)		388 x 203 x 420
Packing dimensions (WxDxH) (mm)		395 x 206 x 405
Number of bins		2
Lid		Lid with turn & tilt mechanism
Capacity (l)		2 x 8
Total volume (l)		16
Color metal parts		stainless steel
Color plastic parts		black

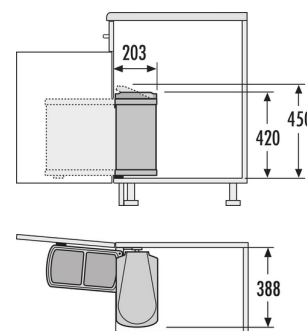



Weight incl. packing (kg)

4,2

---