

# ATL3500

## Instruction Manual

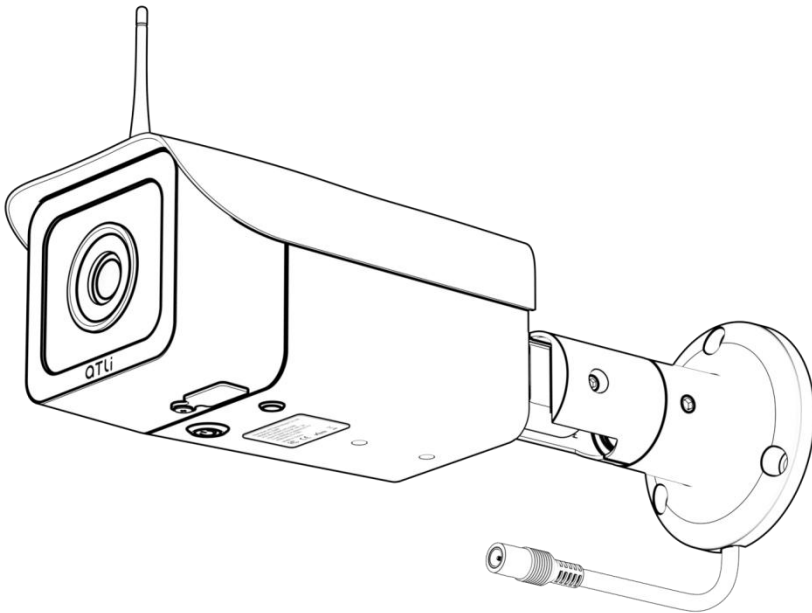

This instruction manual covers the camera installation and setup procedures of the ATL3500 time lapse camera.

Please visit <https://www.atlitimelapse.com/pages/download-manual> to download **IN-APP CONTROL INSTRUCTION** for more information on how to connect and control the camera.

# Content Index

Welcoming Notes.....	3
Safety Precautions & Warnings.....	3
Installation.....	3
Electrical Safety.....	4
Transportation Security.....	4
Repair.....	4
Environment.....	5
Operation and Maintenance.....	5
Product Introduction.....	6
Overview.....	6
Package Content.....	6
Name of Camera Parts.....	7
Installation.....	8
Wi-Fi Antenna.....	8
Camera.....	8
Power.....	10
Quick Setup.....	11
Installing ATLI Cam App.....	11
Remote access.....	12
Camera Status.....	13
Troubleshooting.....	15
Hard restart.....	17
Reset to factory settings.....	17
Specifications.....	18
Warranty.....	20

# Welcoming Notes

---

Thank you for purchasing ATL3500.

- Please read this manual for proper usage before using the camera.
- Please read and understand the Safety Precautions and Warnings in this manual before using the camera.
- Please keep this manual for future references.

## Safety Precautions & Warnings

---

Please read the following safety precautions and warnings carefully below before using the camera.

They are important to avoid personal injury and damage.

### Installation

- Handle the camera with care and avoid dropping it which could cause internal hardware damage.
- Keep the camera clean, especially the front protective glass.
- Do not connect the camera to a third-party power adaptor.
- Do not place any objects on top of the camera.

## Electrical Safety

- This camera is designed to connect to a 12V-DC power source ONLY. It is recommended to use the power adaptor that is included in the package. Incompatible third party power adaptor may damage the hardware permanently.
- Installation must conform to your local electrical safety codes.
- We assume no liability or responsibility for any fires, electrical shock, and damage caused by improper handling or installation.
- **WARNING: DO NOT CONNECT THE CAMERA TO AC POWER SOURCE DIRECTLY WITHOUT USING AN AC POWER ADAPTOR.**

Doing so may cause electric shock, fire, damage to the camera, or personal injury. Always use the AC power adaptor that is compatible with the camera and the voltage of your region.

## Transportation Security

- Avoid heavy stress, violent vibrations, and excess moisture during transportation, storage, and installation of the camera.

## Repair

- Disassemble the camera will automatically void the warranty.
- We are not liable for any problems or damage caused by unauthorized modifications or user-attempted repair.

- Contact us via email [service@atliview.com](mailto:service@atliview.com) for any technical issues.

## **Environment**

- The recommended operating temperature is between 0°C/32°F to 50°C/122°F.
- Avoid aiming the camera lens directly to the sun to avoid pictures from overexposure and may possibly damage the camera image sensor in the long run.
- Installing the camera under a roof or shelter could help to improve the camera's life and bring extra benefits to the quality of the recorded video/photo footage.

## **Operation and Maintenance**

- The camera is designed and manufactured for weatherproof (IP65 standard compliance).
- This product is NOT waterproof and shall not be used under water.
- To avoid scratches on the front protective glass, use only an air blower or a microfiber cloth for cleaning.

# Product Introduction

## Overview

ATL3500 is an app-control 1080P time lapse camera which is specifically designed for capturing high-resolution outdoor time-lapse video.

With an IP65 water resistance rating and its durable housing made from aircraft-grade aluminum alloy, the camera is able to withstand even the extreme weather conditions.

## Package Content

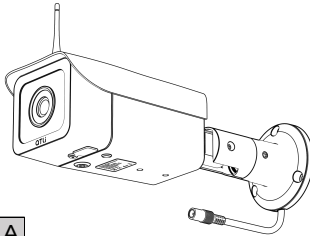

A



B

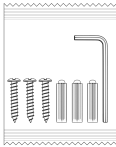

C

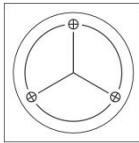

D



E

A	ATL3500 with 128GB storage card	B	12V=2A AC Power Adaptor	C	Screw*3, Wall Plug*3, Hex key
D	Installation Position Sticker	E	Wi-Fi Antenna		

# Name of Camera Parts

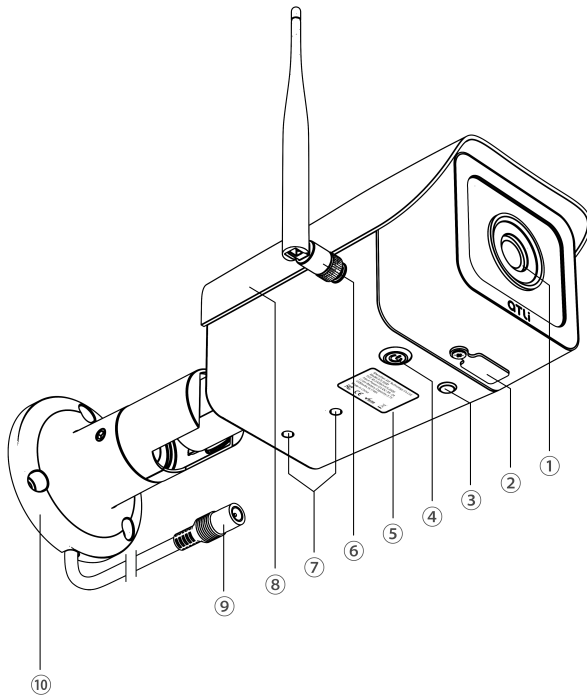

1	Protective Glass	6	Wi-Fi Antenna
2	Storage Card Slot Cover	7	1/4" Tripod Mount
3	Power Source Indicating LED	8	Camera Roof
4	Power Button with Status Indicating LED	9	Power Connector
5	Safety Label	10	Wall Mounting Bracket

# Installation

---

## Wi-Fi Antenna

Assemble the Wi-Fi antenna to the camera by turning the base ring clockwise against the base mount on the camera body by hand **ONLY** until tightened.

Do not use excess force or a tool to over-tighten the antenna.

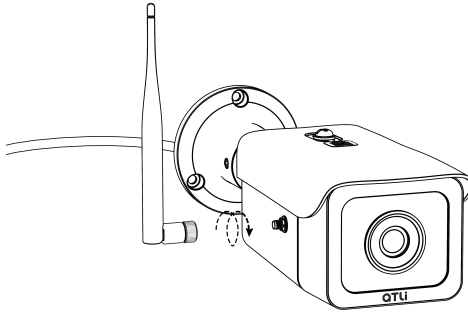

## Camera

The camera comes with a standard wall mount and should be installed as shown below.

Please make sure that the wall is sturdy, and the mounting surface is rigid to withstand strong wind.

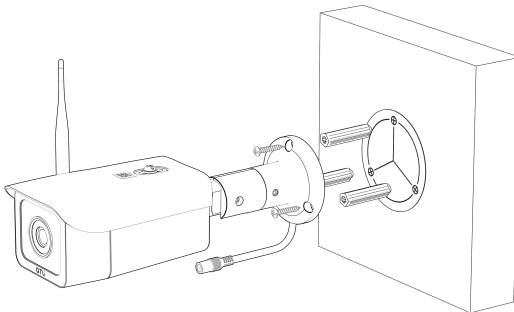

Wall Mount (Standard)



The wall mount bracket is adjustable with 360 degrees swivel on the base, 90 degrees tilting angle, and 360 degrees swivel on the camera body. This offers more flexibility when installing the camera.

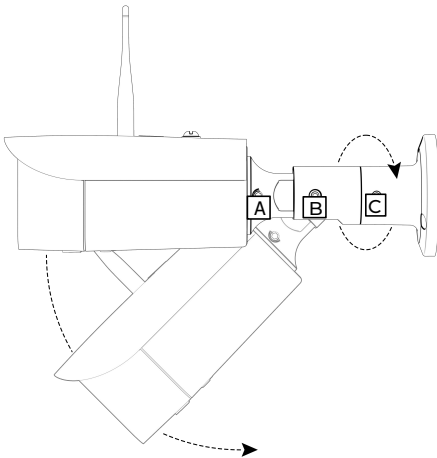

1. Loosen the bolt **C** to swivel the camera so that it is pointing to the direction of the scene desired and then tighten it back.
2. Loosen the bolt **B** to adjust the tilting angle as desired and then tighten it back.
3. Loosen the bolt **A** to swivel the camera to adjust the orientation of the scene desired and then tighten it back.

The other mounting option is to remove the wall mount, then mount a c-clamp (not included) to the 1/4" mounting point located at the bottom of the camera.

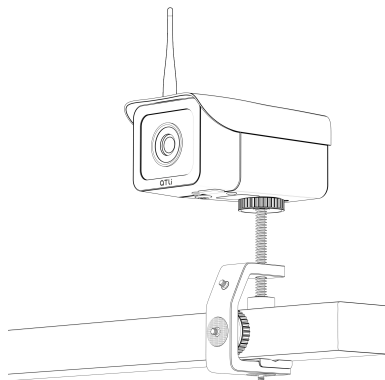

Mounting with a c-clamp (Available for purchase separately)

To remove the wall mount arm from the camera:

1. Loosen the bolt **C** to remove the wall mount base,
2. Remote the bolt **B** to disconnect the middle arm from the camera mount. This is necessary so that the power cable can be separated from the arm.
3. Loosen the bolt **A** so that the camera mount can be disconnected from the camera body.

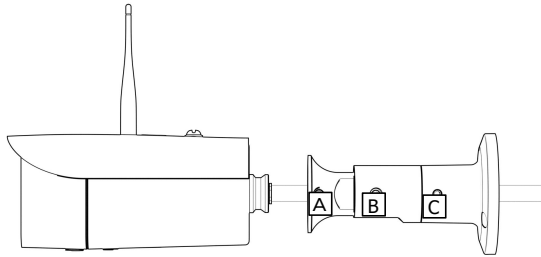

## Power

Use the power adaptor provided to connect to the camera power plug. Incompatible third-party power adaptor may damage the camera permanently.

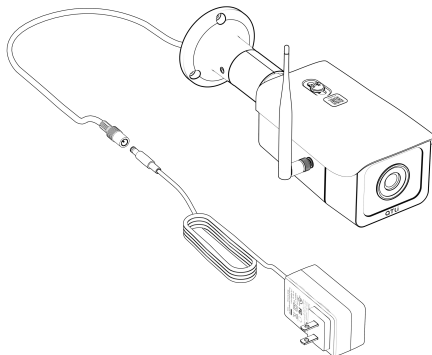

**WARNING:** Do not connect AC power source to the 12V-DC female plug as this will damage the camera and cause fire, electric shock, and other serious hazards. In addition, the product warranty is voided automatically.

# Quick Setup

---

## Installing ATLI Cam App

Scan the QR code on the right to install ATLI Cam App.

The ATLI Cam App can also be installed via the Apple App Store or an Android App Store.



## Registering the Camera to the ATLI Cam App

- a. Open ATLI Cam App to display the Discover home screen. Time lapse videos and tutorial videos are available in this page.
- b. Turn the camera upside down to view the camera QR code as shown on the right.  
\*A backup camera QR code is located at the bottom of the camera roof.
- c. Click on the [Camera] icon at the bottom and then click on [Add Camera] to register your camera.
- d. Scan the camera QR code to connect.
- e. Switch back to ATLI Cam App to connect the camera to view the camera dashboard.

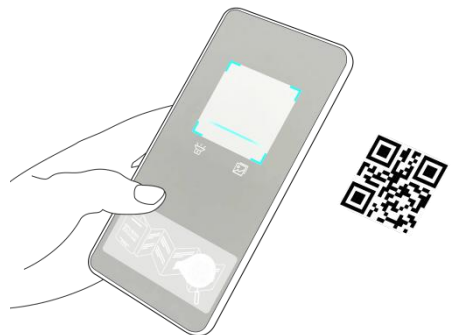
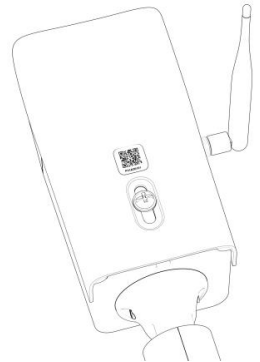

## Remote access

The Remote access feature allows users to access and control the camera from any location with our software application.

Before you begin, please ensure you have the software application installed to your device.

For PC:

Please visit <https://www.atlitimelapse.com/pages/atli-remote-access-beta-download> to install the ATLI Remote.

For Mobile:

Please visit <https://www.atlitimelapse.com/pages/atli-cam-app-download> to install the ATLI Cam app.

To get started, create an account and follow the in-app instructions to proceed.

Ensure that the camera's WLAN is properly configured and connected to a Wi-Fi network with internet to use this feature.

Ensure that the power saving mode is off when using this feature.

# Camera Status

---

Two LEDs located at the bottom of the camera are used to display the camera status.

## Power Button with Status Indicating LED

Status	Green LED	Description
Powering Up	On for 10 seconds	When the camera is off, press and hold the power button for approximately 5 seconds until the LED turns on. If the camera does not blink, then it fails to power up. Please contact <a href="mailto:service@atliview.com">service@atliview.com</a> for help.
Sleep	On continuously	The camera is sleeping. Press the power button momentarily to wake up the camera.
Local Wi-Fi not connected	Fast blinking (0.5 seconds on/off)	The camera can only be connected via direct Wi-Fi connection.
Local Wi-Fi connected	Slow blinking (1 second on/off)	The camera is connected to the pre-configured local Wi-Fi network. It can be accessed via either the local Wi-Fi or the camera Wi-Fi. If internet access is available, the camera can also be accessed remotely.

## Power Source Indicating LED

Status	Red LED	Description
No external Power	Off	No 12V-DC power source is connected.
External Power connected	On	A 12V-DC power source is connected.

# Troubleshooting

---

Symptom	Solution
Unable to connect the camera	<p>a. Green LED is off – Press and hold the power button until the green LED is on. Wait for the camera is ready (Green LED blinks when it's ready).</p> <p>b. Green LED is steadily on – The camera is in sleep mode. Press the power button momentarily to wake it up.</p> <p>If the camera does not wake up, please hard restart the camera. If the green LED still stays on after power up, please contact <a href="mailto:service@atliview.com">service@atliview.com</a> for help.</p> <p>c. Green LED blinks every 0.5 seconds (fast blinking) – The camera is not connected to a local Wi-Fi network, and it can only connect via the camera Wi-Fi directly. Please make sure that your mobile device is connected to the camera Wi-Fi. Check the phone settings to make sure that the camera Wi-Fi is connected. The camera Wi-Fi SSID is its camera serial number. If you need to connect the camera Wi-Fi manually, you can find the Wi-Fi login password in the camera information which can be located in the camera list.</p> <p>The Wi-Fi signal strength should be in full bar when the mobile device is close to the camera. If not, please double check if the antenna is properly installed.</p>

	<p>d.Green LED blinks every 1 second (slow blinking) – The camera has already connected to the pre-configured local Wi-Fi network. Please check if the mobile device is connected to the same local Wi-Fi network. If it is, please refresh the camera list to see if the camera is online. Please also check if the antenna is properly installed and the camera is not too far away from the router. If you have any doubt, please move the camera closer to the Wi-Fi router and then test again.</p>
Unable to turn on the camera	<p>a.The battery may be depleted. Connect the camera to a 12V-DC power source. Use only compatible DC power adapter. Please make sure that the Red LED is ON and then try to turn on the camera.</p> <p>b.If the Red LED is not ON, please check the DC adapter has a rated output of 12V-DC@2A. If in doubt, please always use the adapter included.</p>

Should you have other issues please contact us at [service@atliview.com](mailto:service@atliview.com) for further support.



# Hard restart

---

Hard restart the camera if the screen is frozen or cannot be powered on normally.

Long press the power button 4 to 5 seconds to shut down the camera. Then press the power button again for 4 to 5 seconds to turn it back on.

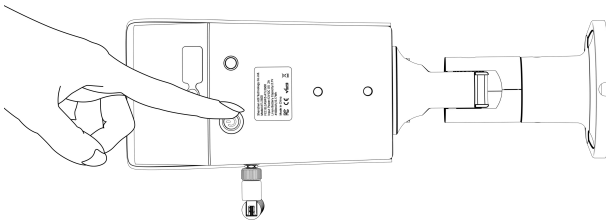

# Reset to factory settings

---

To remove all settings from the camera, reset your camera to factory settings.

Open ATLI Cam app, System Settings > Reset to factory defaults.

# Specifications

---

General	
Lens	6 Elements ASPH. Lens
Aperture	F2.4
Video Resolution	1920*1080
Photo Resolution	2688*1520
Pixel Size	2 $\mu$ m*2 $\mu$ m
Focus Mode	Fixed
Focal Range	3 meters- Infinity
Field of View	110°
App Control	iOS/Android
Remote Access Control	Windows/MacOS
Connectivity	2.4GHz Wi-Fi 802.11 b/g/n
Video/Photo	
Video Format	MP4
Photo Format	JPEG
Playback Frame Rate	25FPS
Schedule	Daily/Weekly/Custom
Interval	0.5s - 24hrs
Charging & Built-in Battery	
Battery Type	Built-in Li-ion Battery
Battery Capacity	4100mAh
External Power Supply	DC 12V $\equiv$ 2A (5.5x2.5mm Plug)
Storage	
Capacity	128GB Storage Card (Max.)
Storage Card Class	Class 10
Design	
Water Resistance	IP65
Operating Temperature	0°C/32°F to 50°C/122°F
Dimensions	88*78*165mm
Weight	890g

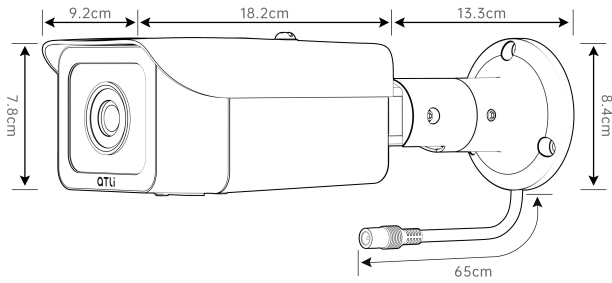

ATL3500 (5.5x2.5mm Plug)

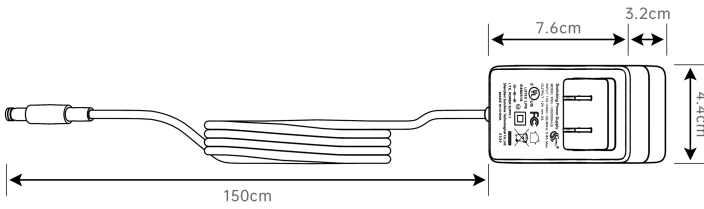

AC Power Adaptor (5.5x2.5mm Socket)

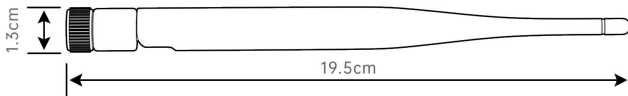

Wi-Fi Antenna

# Warranty

---

## Terms & Conditions

- a. Under normal operation, the product will receive 1-year limited warranty provided by ATLI World Ltd.
- b. Customers who fail to provide the original purchase invoice or register the product online will be disqualified from this warranty.
- c. ATLI will, at its discretion, repair or replace the product or any defective parts.

This limited warranty does not cover any of the followings:

- a. Defects and damages due to loss, theft, fire, water, or a natural disaster.
- b. Failure of damage caused by improper use, carelessness (knocks, dents, crushing, broken glass, etc.), or accidents.
- c. Failure or damage caused by unauthorized repair or modification.
- d. Esthetical changes, defects, and damages due to normal aging (for example: scratches on the case and/or glass)
- e. The shipping cost to and from the designated repair center.

For warranty service, customers must contact us via email to report the problem and obtain authorization first.

Email: [service@atliview.com](mailto:service@atliview.com)

Website: <https://www.atlitimelapse.com>

# FCC WARNING

This device complies with part 15 of the FCC Rules. Operation is subject to the following two conditions: (1) this device may not cause harmful interference, and (2) this device must accept any interference received, including interference that may cause undesired operation.

**WARNING:** Any changes or modifications not expressly approved by the party responsible for compliance could void the user's authority to operate the equipment.

**NOTE:** This equipment has been tested and found to comply with the limits for a Class B digital device, pursuant to Part 15 of the FCC Rules.

These limits are designed to provide reasonable protection against harmful interference in a residential installation.

This equipment generates, uses, and can radiate radio frequency energy and, if not installed and used in accordance with the instructions, may cause harmful interference to radio communications.

However, there is no guarantee that interference will not occur in a particular installation. If this equipment does cause harmful interference to radio or television reception, which can be determined by turning the equipment off and on, the user is encouraged to try to correct the interference by one or more of the following measures:

- Reorient or relocate the receiving antenna.
- Increase the separation between the equipment and receiver.
- Connect the equipment into an outlet on a circuit different from that to which the receiver is connected.
- Consult the dealer or an experienced radio/TV technician for help.

To maintain compliance with FCC's RF Exposure guidelines, this equipment should be installed and operated with minimum 20cm distance between the radiator and your body: Use only the supplied antenna.