

# DRUM MULCHER HEAD

## DRIVE ASSEMBLY - 32-45GPM (119-171LPM)

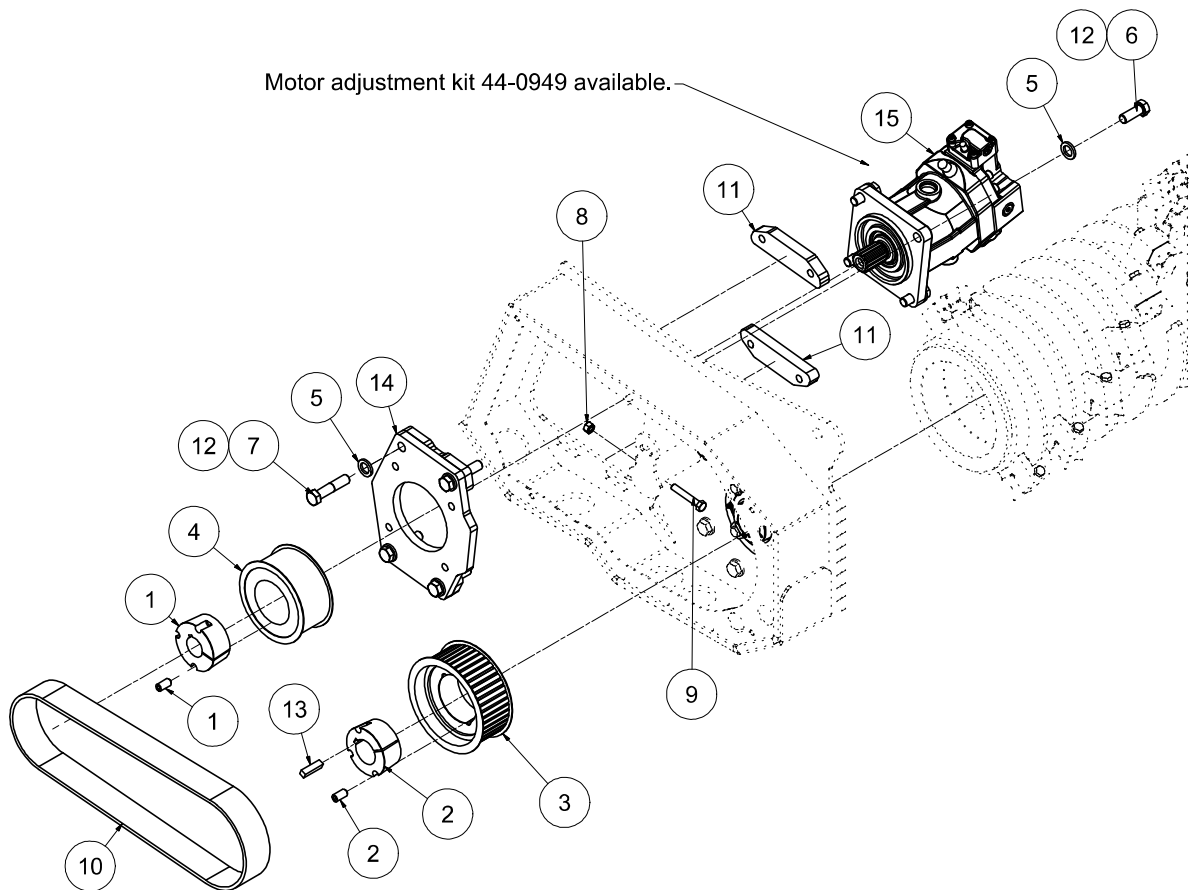

REF#	PARTS DESCRIPTION	REQ	PART#	TORQUE (ft-lbs)
1	BUSHING, 1-3/4 13T, DRUM MULCHER	1	10-1060	60
2	BUSHING, 2-3/16 KEYED, DRUM MULCHER	1	10-1061	60
3	PULLEY, 201MM X 85MM, DRUM MULCHER	1	10-1063	
4	PULLEY, 165MM X 85MM, DRUM MULCHER	1	10-1064	
5	3/4 SAE GR 8 FLAT WASHER, YELLOW	8	11-0039	
6	3/4-10 X 2 GR 8 HEX CAP, YELLOW ZINC	4	11-0751	376
7	3/4-10 X 3-1/2 GR 8 HEX CAP, YELLOW ZINC	4	11-0792	376
8	1/2-13 GR 5 HEX NUT, ZINC	1	11-1016	
9	1/2-13 X 3 GR 8 HEX CAP, YELLOW ZINC FULL THREAD	1	11-2206	106
10	BELT, HT500, 68MM X 1568MM, DRUM MULCHER	1	12-0082	
11	MOTOR MOUNT CLAMP PLATE, DRUM MULCHER	2	24-0368	
12	LOCTITE 262, .017 OZ (RED)	1	24-0382	
13	KEY 1/2 X 1/2 X 2	1	37-0026	
14	MOTOR MOUNT, DRUM MULCHER	1	41-1606	
15	VARIABLE DISPLACENT BENT AXIS PISTON MOTOR	1		
	3000 PSI CARRIER SETTING		30-0586	
	3300 PSI CARRIER SETTING		30-0585	
	3500 PSI CARRIER SETTING		30-0584	
	4000 PSI CARRIER SETTING		30-0545	