

35-0010 Spindle Assembly

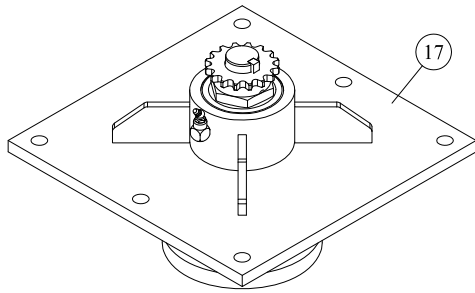

* Complete spindle assemblies also available.
Diamond Part #35-0010

**Do not use #2 heavy-duty grease on spindle assembly. Use Diamond spindle grease parts #23-0001

***Complete spindle repair kits available.
These kits include 10-0003, 10-0004, 10-0008, 10-0014, 10-1002, 11-0002, 11-1009, 11-1010, 33-0001, 33-0003 & 37-0009. These can be purchased using part #44-0001

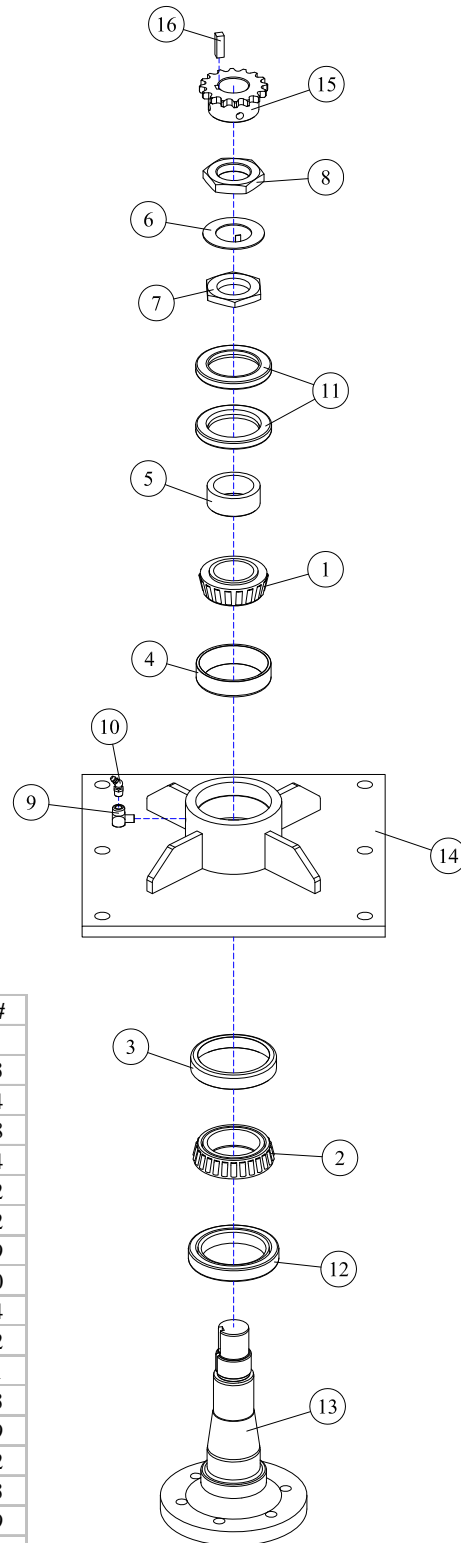

REF#	PARTS DESCRIPTION	REQ	PART #
1	BEARING CONE	1	10-0003
2	BEARING CONE	1	10-0004
3	BEARING CUP	1	10-0008
4	BEARING CUP	1	10-0014
5	BEARING ADJUSTMENT SLEEVE	1	10-1002
6	JAM WASHER	1	11-0002
7	ADJUSTMENT BEARING NUT	1	11-1009
8	ADJUSTMENT BEARING NUT	1	11-1010
9	1/8 X 90DEG ELBOW	1	21-1104
10	1/8" X 45 GREASE ZERK	1	23-0002
11	UPPER SEAL SET	1	33-0001
12	LOWER SEAL	1	33-0003
13	SPINDLE	1	35-0009
14	SPINDLE HOUSING	1	35-0012
15	SPROCKET	1	37-0003
16	SPINDLE KEY	1	37-0009
17*	SPINDLE ASSY COMPLETE	Avail	35-0010
18**	DIAMOND SPINDLE GREASE	Avail	23-0001
19***	SPINDLE REPAIR KIT	Avail	44-0001