

# Double Head Switch Box

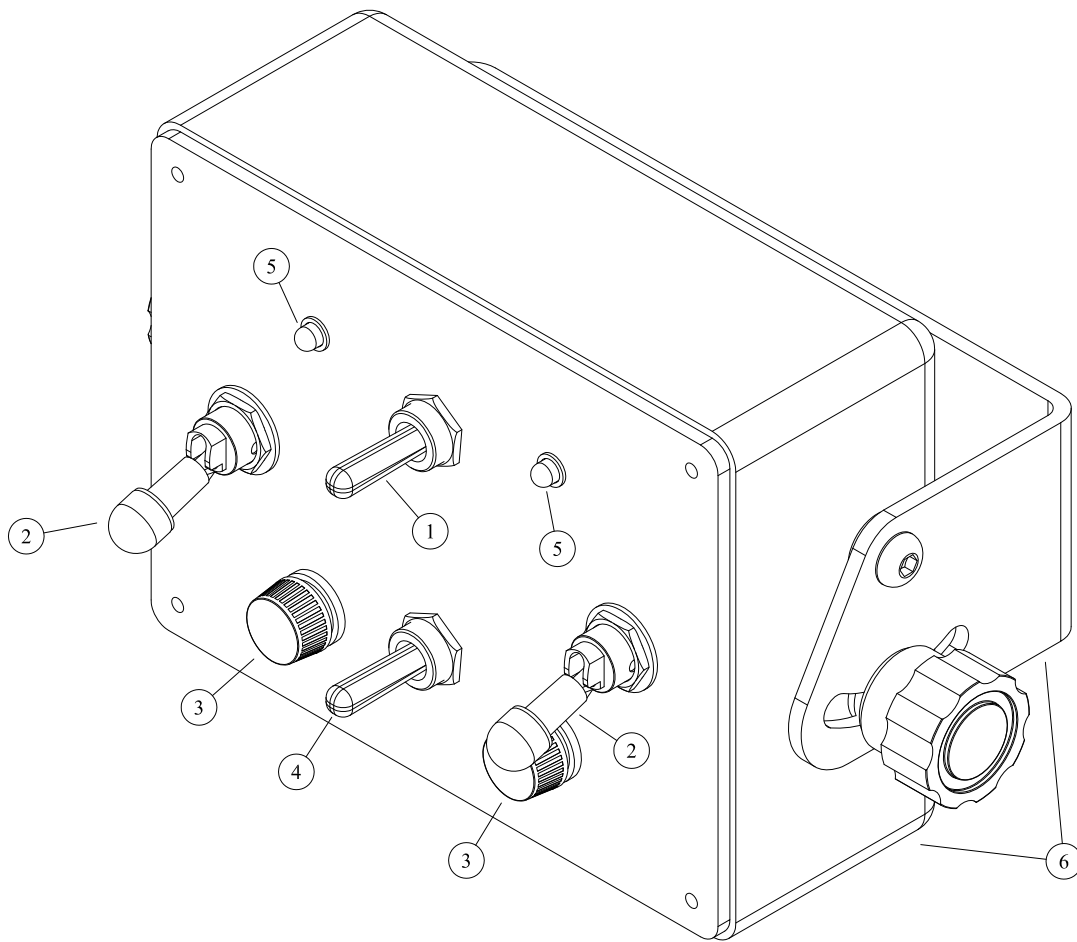

REF#	PARTS DESCRIPTION	REQ	PART #
1	FAN REVERSING SWITCH	1	16-0004
2	ON/OFF SWITCH	2	16-0005
3	FUSE HOLDER	2	16-0007
4	LOCK SWITCH (OPTIONAL)	1	16-0013
5	LED INDICATOR	2	16-0055
6	ENCLOSURE W/ BRACKETS	1	16-0060