



Create amazing spaces™

MANUAL

CORTINA™ 77

USER MANUAL | MODE D'EMPLOI | MANUAL DEL USUARIO | MONTAGEANLEITUNG |
MONTAGEHANDLEIDING | MANUALE PER L'UTENTE | MANUAL DO UTILIZADOR | 조립설명서

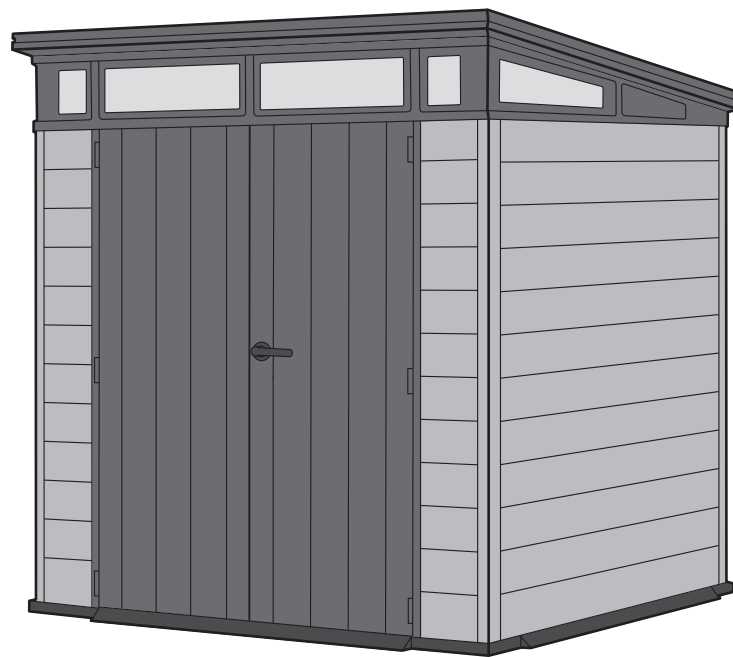

IMPORTANT | IMPORTANT | IMPORTANTE

RETAIN FOR FUTURE REFERENCE: READ CAREFULLY
À CONSERVER POUR DE FUTURS BESOINS DE RÉFÉRENCE : À LIRE SOIGNEUSEMENT
CONSERVE PARA FUTURA REFERENCIA. LEA CUIDADOSAMENTE

For outdoor use only. Not for commercial use | Utilisation non commerciale à l'extérieur seulement |
Para uso externo. No para uso comercial.

WWW.KETER.COM

US, Canada
Tel: +1877-638-7056, NACS@keter.com
Mon - Fri | 8am - 6pm ET / Lundi-Vendredi 8h -18h
Sat - Sun | 9am - 6pm ET / Samedi-Dimanche 9h-18h

UK
Tel: +44-121-506-0008, CSUK@keter.com
Mon - Fri | 8:30am - 5pm

For other European countries see the last page
Pour les autres pays d'Europe, voir la dernière page
Para otros países europeos vea la última página

A-1615 5012990

WARRANTY ACTIVATION

Thank you for your purchase of the Keter shed.
In order to activate your warranty, please log onto
our website and fill in the form under warranty
activation.

ACTIVATION DE LA GARANTIE

Nous vous remercions pour l'achat de votre abri
Keter. Pour activer votre garantie, veuillez vous
connecter à notre site Web et remplir le formulaire
d'activation de la garantie.

ACTIVACION DE GARANTIA

Gracias por su compra de una caseta Ket er. Para
activar su garantía, ingrese en nuestro sitio de
internet y complete el formulario que esta bajo la
activacion de garantia.

keter.com/en/warrant-activation

Level the ground surface | Nivelez la surface du sol | **Nivele la superficie del suelo** | Ebenen Sie die Bodenoberfläche | **Maak de bodem vlak** | Livellare la superficie del terreno | **Nivele a superficie do solo** | 땅고르기

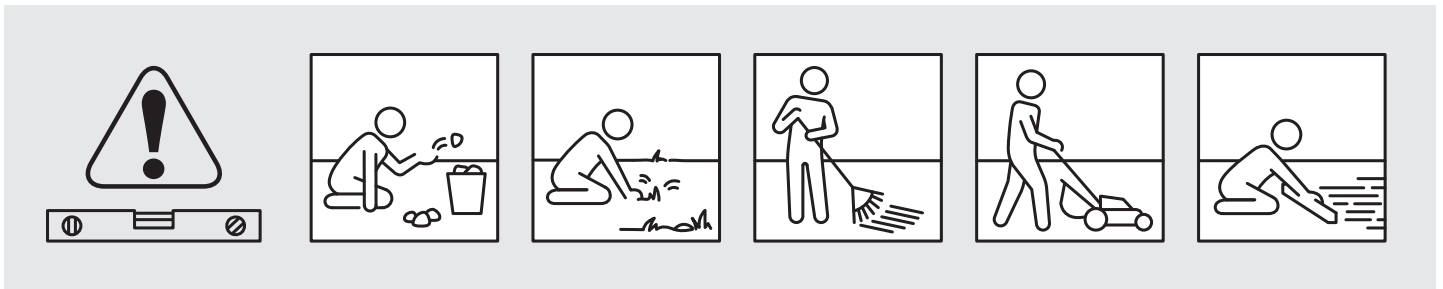

Recommendation: Construct a wooden or concrete base as a foundation | Recommendation: Fabriquez une base en bois ou en béton en guise de fondation | **Recomendación: construya una base de madera o de cemento a modo de cimiento** | Empfehlung: Bauen Sie als Fundament eine Grundfläche aus Holz oder Beton | **Aanbeveling: maak een houten of betonnen ondergrond als fundering** | Raccomandazione: Costruire una base di legno o di cemento come fondamenta | **Recomendação: Construa uma base de madeira ou de cimento como fundação** | 추천사항 : 데크나콘크리트바닥을권장합니다.

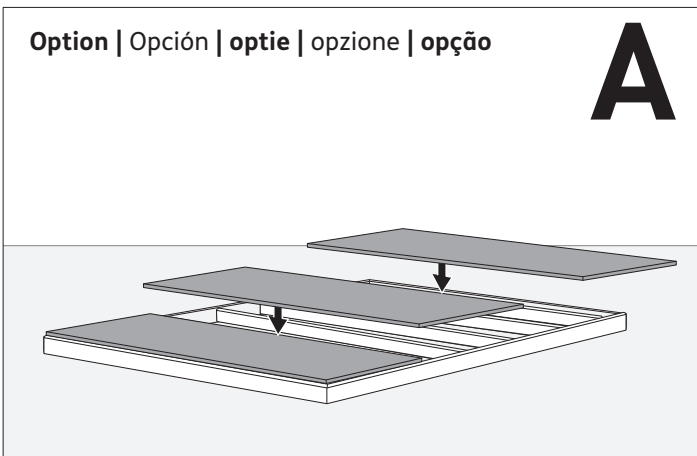

For external access during assembly, make sure to leave enough room around the outside of the shed assembly site.

Pour un accès externe au cours du montage, veillez à laisser suffisamment de place autour du site de montage.

Para tener un acceso exterior durante el montaje, asegúrese de dejar suficiente espacio alrededor del lugar de montaje del cobertizo.

Lassen Sie am Aufstellungsort außerhalb des Schuppens ausreichend Platz, so dass Sie während des Aufbaus von außen Zugang zum Schuppen haben.

Om tijdens de montage aan de buitenkant van het schuurtje te kunnen werken, moet u ervoor zorgen dat u genoeg ruimte laat aan de buitenkant van de montageplaats.

Per l'accesso esterno durante il montaggio, assicurati di lasciare abbastanza spazio intorno alla parte esterna del luogo di montaggio del deposito attrezzi.

Para ter acesso externo durante a montagem certifique-se de que deixa espaço suficiente em redor do exterior do local de montagem do abrigo.

조립시에 외부 작업이 필요하므로 충분한 공간을 마련하고 작업하시기 바랍니다.

External floor measurements are: | Mesures externes du plancher: | **Las medidas del suelo externo son:** | Die Außen-Bodenmaße betragen: | **De afmetingen van de externe vloer zijn:** | Le misure del pavimento esterno sono: | **As medidas externas do chão são:** | 외부 바닥 치수:

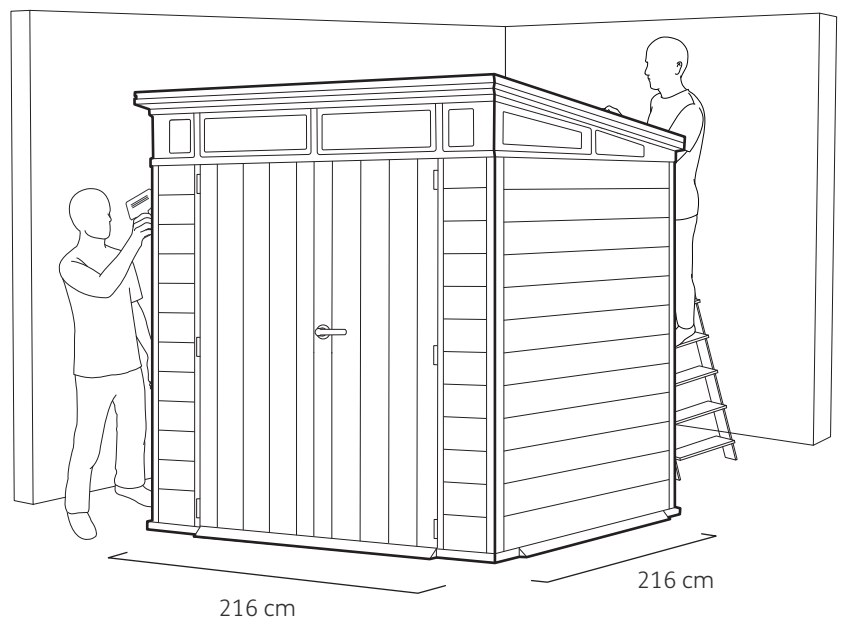

BEFORE STARTING ASSEMBLY | AVANT DE COMMENCER LE MONTAGE | **ANTES DE EMPEZAR EL ARMADO** | VOR MONTAGEBEGINN | **VOORDAT U BEGINT TE MONTEREN** | PRIMA DI INIZIARE L'ASSEMBLAGGIO | **ANTES DE INICIAR A MONTAGEM** | 조립을 시작하기 전에 확인할 내용

Read the care and safety guidelines at the end of this manual | Check to ensure that there are no missing or damaged parts BEFORE starting or arranging assembly | Remove all parts from the package(s) and spread them out on a clean work surface | Review all assembly instructions | Assemble all the parts according to the directions in this manual. Do not skip any steps.

Lisez les instructions de précaution et de sécurité à la fin de ce manuel | Assurez-vous qu'il n'y a pas de pièces manquantes ou endommagées AVANT de commencer ou d'organiser l'assemblage | Retirez toutes les pièces du/des paquet(s) et étalez-les sur une surface de travail propre | Lisez toutes les instructions de montage | Assemblez toutes les pièces selon les instructions de ce manuel. Ne sautez aucune étape.

Lea las intrucciones de precauciones y seguridad que están al final de este manual | Asegúrese de que no faltan piezas ni están dañadas ANTES de comenzar o disponer el montaje | Saque todas las piezas del paquete o paquetes y póngalas sobre una superficie de trabajo limpia | Revise todas las instrucciones de montaje | Monte todas las piezas según las instrucciones de este manual. No se saltee ningún paso.

Lesen Sie die Sicherheitsrichtlinien am Ende des Benutzerhandbuchs durch | Prüfen Sie bitte VOR dem Zusammenbau, dass keine Teile beschädigt sind oder fehlen | Nehmen Sie alle Teile aus der Verpackung und breiten Sie sie auf einer sauberen Arbeitsfläche aus | Gehen Sie noch einmal die komplette Aufbauanleitung durch | Bauen Sie alle Teile entsprechend der Anleitung in diesem Handbuch zusammen. Lassen Sie dabei keinen Arbeitsschritt aus.

Lees de richtlijnen voor zorg en veiligheid achterin deze handleiding | Controleer dat er geen onderdelen mankeren, of beschadigd zijn, VOORDAT u met de montage begint | Haal alle onderdelen uit het pakket (of uit de pakketten) en leg ze opeen schoon werkoppervlak | Bekijk alle montagehandleidingen | Monteer alle onderdelen volgens de aanwijzingen van deze handleiding. Sla geen stappen over.

Leggere le linee guida di assistenza e sicurezza alla fine di questo manuale | Assicurarsi che non ci siano parti mancanti o danneggiate PRIMA di iniziare l'assemblaggio | Estrarre tutti i componenti dall'imballo e posizzarli su una superficie di lavoro pulita | Consultare tutte le istruzioni di montaggio | Assemblare tutti i componenti secondo le istruzioni contenute nel manuale. Non saltare nessuna fase.

Leia as diretrizes de cuidados e segurança que constam da parte final deste manual | Verifique para se assegurar de que não há peças em falta ou danificadas ANTES de começar a preparar a montagem | Retire todas as peças da embalagem e espalhe-as numa superfície de trabalho limpa | Reveja todas as instruções de montagem | Monte todas as peças de acordo com as instruções do manual. Não salte quaisquer passos.

뒷쪽에 있는 조립, 관리 및 안전에 관한 주의사항을 읽어주십시오.

조립설명서 전체 내용을 확인해 보십시오.

반드시 조립설명서 대로 조립하시고 어떤 단계도 건너뛰지 마십시오.

REQUIRED TOOLS | OUTILS EXIGÉS | **HERRAMIENTAS NECESARIAS** | BENÖTIGTE WERKZEUGE | **BENODIGD GEREEDSCHAP** | ATTREZZATURA OCCORRENTE | **FERRAMENTAS NECESSÁRIAS** | 필요한 도구

Tools and accessories not included | Outils et accessoires non inclus | **Herramientas y accesorios no incluidos** For outdoor use | Usage extérieur | **Para uso externo Assembly required** | À monter soi-même | **Se requiere ensamblaje**

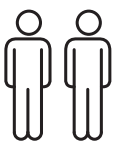
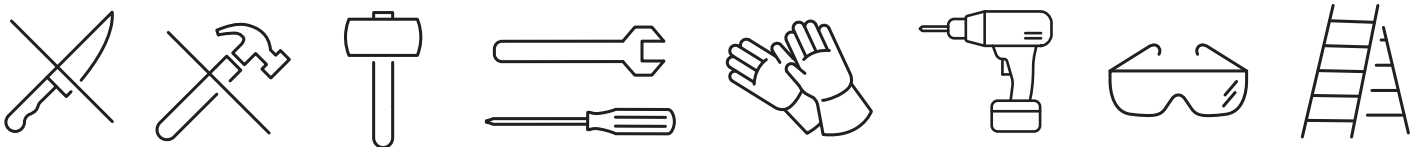

ASSEMBLY REQUIRES TWO PEOPLE | LE MONTAGE DOIT ÊTRE EFFECTUÉ PAR DEUX PERSONNES | **SE NECESITAN DOS PERSONAS PARA ARMARLO** | ZWEI PERSONEN ZUR MONTAGE NOTWENDIG | **MONTAGE VEREIST TWEE PERSONEN** | L'ASSEMBLAGGIO RICHIEDE DUE PERSONE | **A MONTAGEM EXIGE DUAS PESSOAS** | 두 명 이상의 성인이 조립하십시오

Remove all parts from the package(s) and spread them out on a clean work surface | Code letters are imprinted on each part for easy identification | Retirez toutes les pièces du/des paquet(s) et étalez-les sur une surface de travail propre | Des lettres sont imprimées sur chaque pièce pour une identification facile | Saque todas las piezas del paquete o paquetes y póngalas sobre una superficie de trabajo limpia | El código de letras está marcado en cada pieza para que sea más fácil identificarla | Nehmen Sie alle Teile aus der Verpackung und breiten Sie sie auf einer sauberen Arbeitsfläche aus | Auf jedem Teil sind Kennbuchstaben aufgedruckt, die die Zuordnung der einzelnen Teile erleichtern | Haal alle onderdelen uit het pakket (of uit de pakketten) en leg ze op een schoon werkoppervlak | Op ieder onderdeel zijn codes aangebracht voor een gemakkelijke identificatie | Rimuovere tutti i componenti dall'imballo e posizzionarli su una superficie di lavoro pulita. | I codici identificativi sono impressi in ogni componente per una semplice identificazione | Retire todas as peças da embalagem e espalhe-as numa superfície de trabalho limpa | Existem letras de código impressas em cada peça para fácil identificação | 모든 부품을 포장 박스에서 꺼내 깨끗한 바닥에 펼쳐주십시오. 부품번호는 각 부품에 각인 되어 있습니다. 부품누락, 파손의 경우 고객센터로 연락 주십시오.

FLOOR PARTS | ÉLÉMENTS DU PLANCHER | PARTES DEL SUELO | BODENTEILE | VLOERPANELEN | COMPONENTI DEL PAVIMENTO | PEÇAS DO CHÃO | 바닥 부품

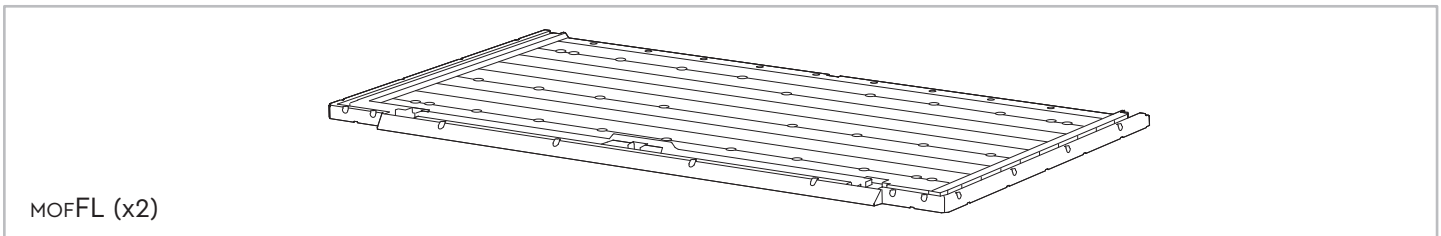

WALL PARTS | PIÈCES DES MURS | PARTES DE LAS PAREDES | WANDELEMENTE | MUURONDERDELEN | COMPONENTI DELLE PARETI | PAINÉIS LATERAIS | 벽 부품

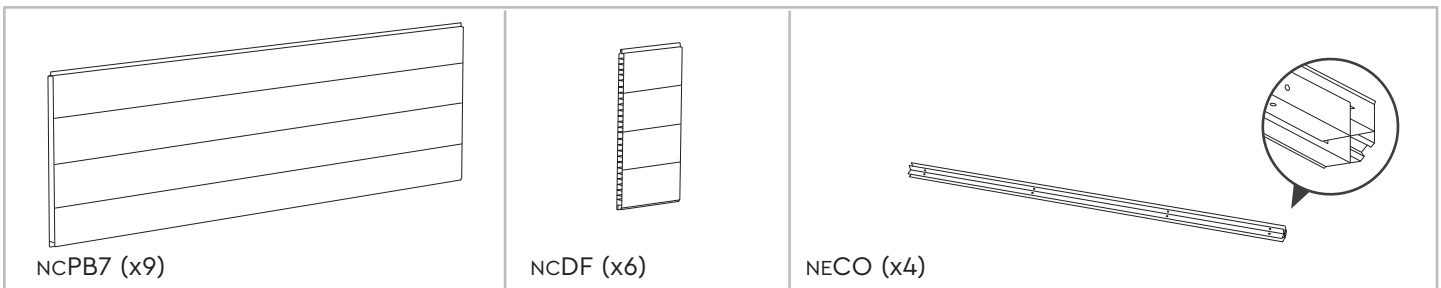

DOOR PARTS | PIÈCES DE LA PORTE | PARTES DE LA PUERTA | TÜRELEMENTE | DEURONDERDELEN | COMPONENTI DELLA PORTA | PEÇAS DAS PORTAS | 문 부품

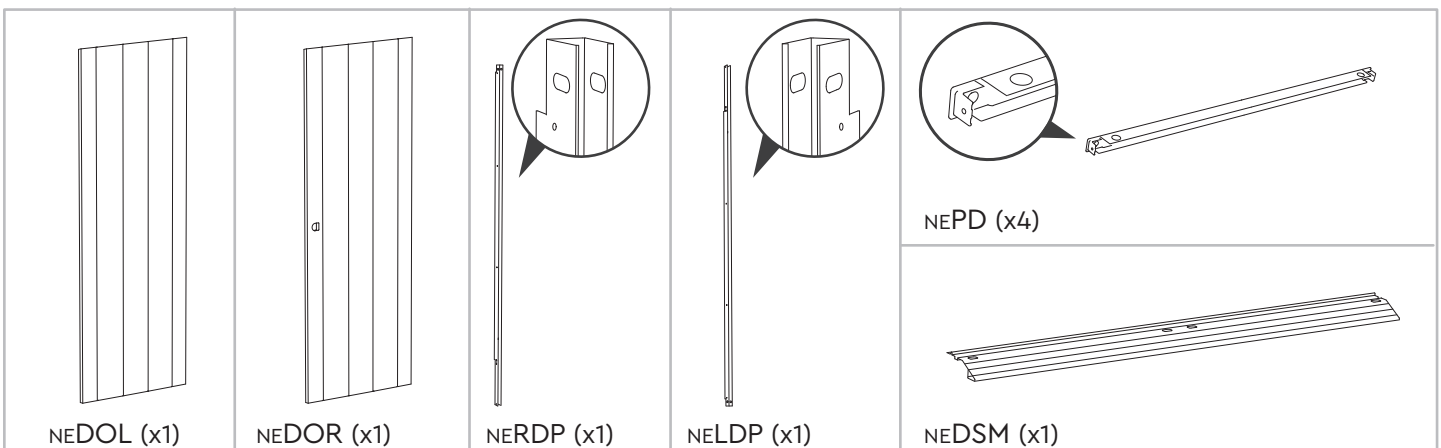

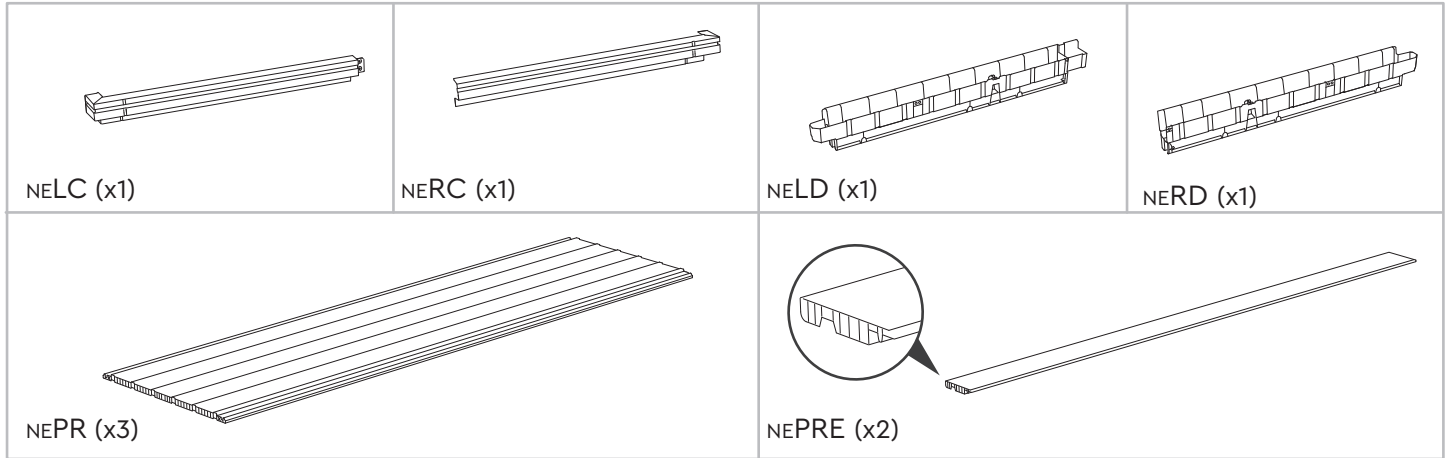

ROOF PARTS | PIÈCES DU TOIT | PARTES DEL TECHO | DACHELEMENTE | DAKONDERDELEN | COMPONENTI DEL TETTO | PEÇAS DO TELHADO | 지붕 부품



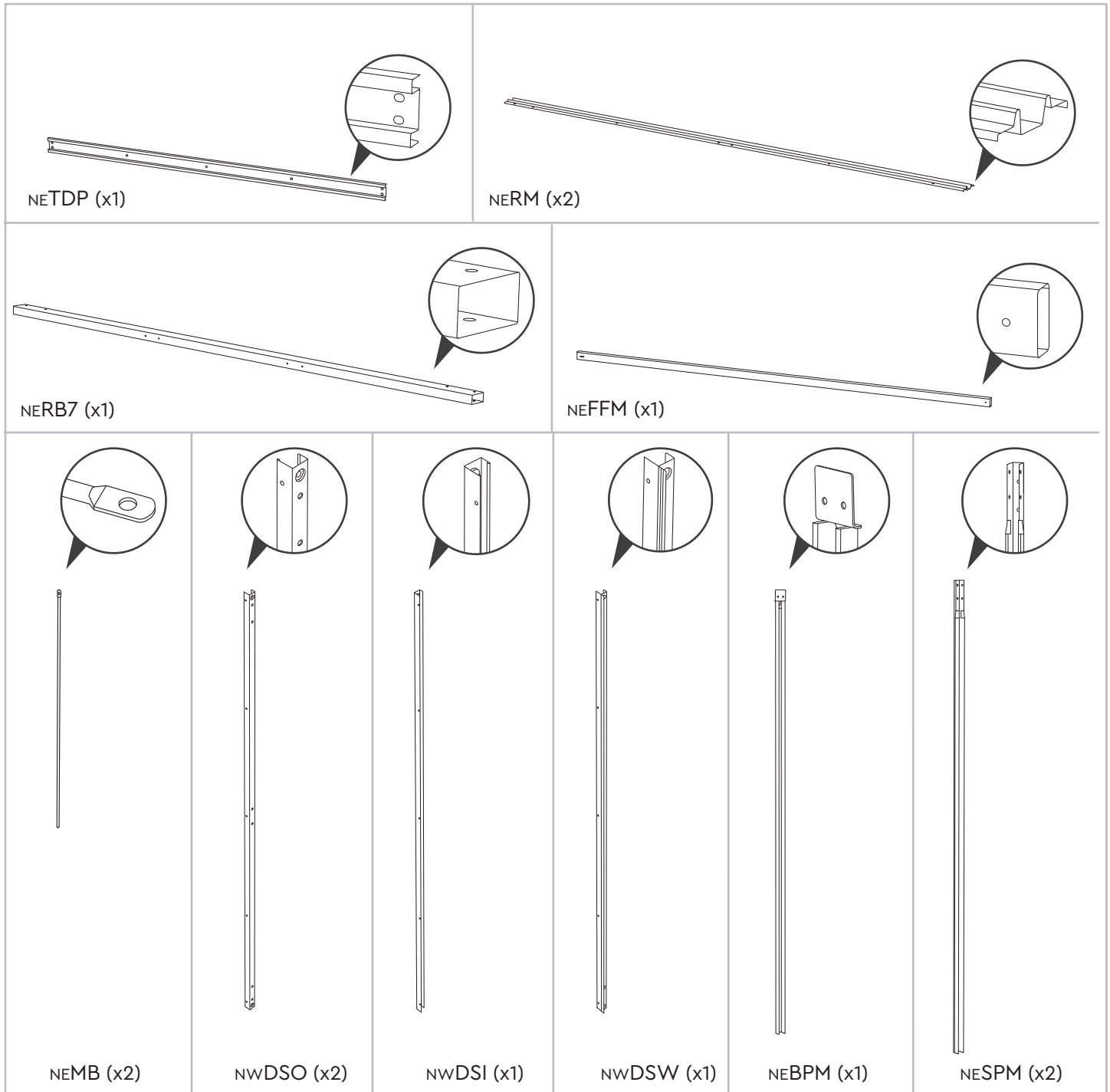



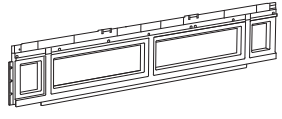
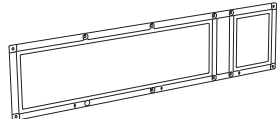
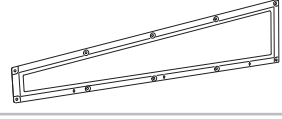
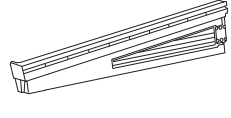
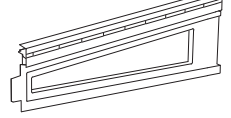
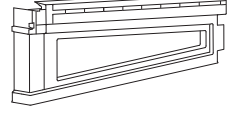



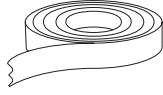
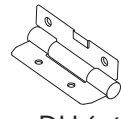
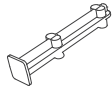
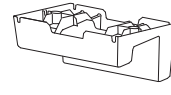
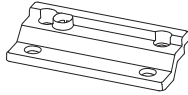
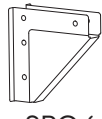

METAL PARTS | PIÈCES MÉTALLIQUES | PIEZAS METÁLICAS | METALLTEILE | METALEN DELEN | COMPONENTI IN METALLO | PARTES METÁLICAS | 금속 부품

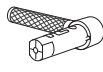

WINDOW PARTS | PIÈCES DE LA FENÊTRE | PARTES DE LA VENTANA | FENSTERELEMENTE | VENSTERONDERDELEN | COMPONENTI DELLE FINESTRE | PEÇAS DA JANELA | 창문 부품

 NEFF (x1)	 NEGR (x2)	 NEGT (x2)	
 NEBLT (x1)	 NELT (x1)	 NERT (x1)	 NEBRT (x1)

SMALL PARTS | PETITES PIÈCES | PARTES PEQUEÑAS | KLEINTEILE | KLEINE ONDERDELEN | MINUTERIA | PEÇAS PEQUENAS | 소형 부품

 NEPL	 NEDH (x6)	 NUHF (x2)	 NERA (x2)	 NEDS (x1)	 NESPC (x2)
 NUHG (x2)	 NUHH (x2)	 NUHB (x1)	 NUHA (x1)	 NUHC (x1)	 NERK (x3)
 NUHD (x1)	 NUHE (x1)	 NEDPC (x2)	 NUHW (x1)		

SCREWS | VIS | TORNILLOS | SCHRAUBEN | SCHROEVEN | VITI | PARAFUSOS | 나사

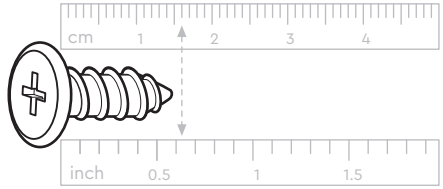
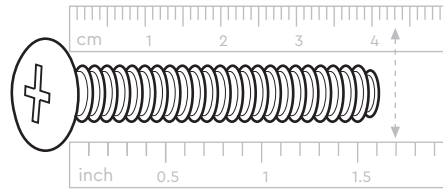
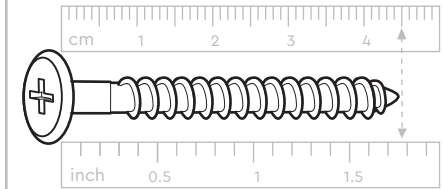
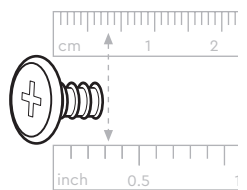
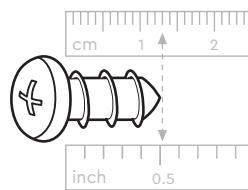
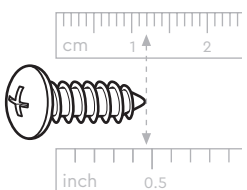
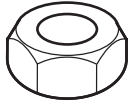
 sc15 (x222) 16 mm / 0.63"	 sc8 (x9) 43 mm / 1.69"	 s45b (x28) 45 mm / 1.77"	
 sc7t (x12) 7 mm / 0.63"	 scw1 (x28) 12.7 mm / 0.5"	 s13b (x59) 12 mm / 0.47"	 scn8 (x9)

Packaging may contain some additional small parts for use as spare parts | L'emballage peut contenir de petites pièces supplémentaires à utiliser comme pièces de rechange | El envoltorio puede contener algunas piezas pequeñas adicionales que se pueden utilizar como repuestos | In der Verpackung können kleine Zusatzteile enthalten sein, die als Ersatzteile genutzt werden können | De verpakking kan een aantal kleine extra onderdelen bevatten, die als reserveonderdeel gebruikt kunnen worden | La confezione potrebbe contenere piccole parti supplementari da utilizzare come parti di ricambio | A embalagem pode conter algumas pequenas peças adicionais para utilização como peças de reposição | 예비부품이 들어 있을 수 있습니다.

NOTE: Due to variations in production, the actual assembled size may vary slightly from the specified dimensions.
REMARQUE: En raison de variantes dans la production, la taille de montage réelle peut différer quelque peu des dimensions indiquées.
NOTA: debido a las variaciones en la producción, el tamaño real al montarlo puede variar ligeramente con respecto a las dimensiones especificadas.
BITTE BEACHTEN: Aufgrund von Abweichungen in der Herstellung kann die tatsächliche Größe leicht von den angegebenen Maßen abweichen.
LET OP: vanwege afwijkingen in de productie kan de werkelijke afmeting na montage een klein beetje afwijken van de opgegeven afmetingen
NOTA: A causa di variazioni nella produzione, le dimensioni effettive del prodotto o assemblato potrebbero variare leggermente da quelle indicate.
NOTA: Devido a variações na produção o tamanho real da montagem poderá variar ligeiramente das dimensões especificadas.
 제작 특성상 명시된 사이즈와 실제 사이즈는 조금 다를 수 있습니다.

FLOOR ASSEMBLY | MONTAGE DU PLANCHER | MONTAJE DEL SUELO | MONTAGE DER BODENPLATTE |
VLOERMONTAGE | ASSEMBLAGGIO DEL PAVIMENTO | MONTAGEM DO PISO | 바닥 조립

1

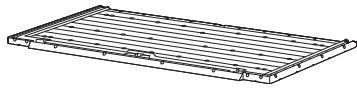

MOFFL (x2)

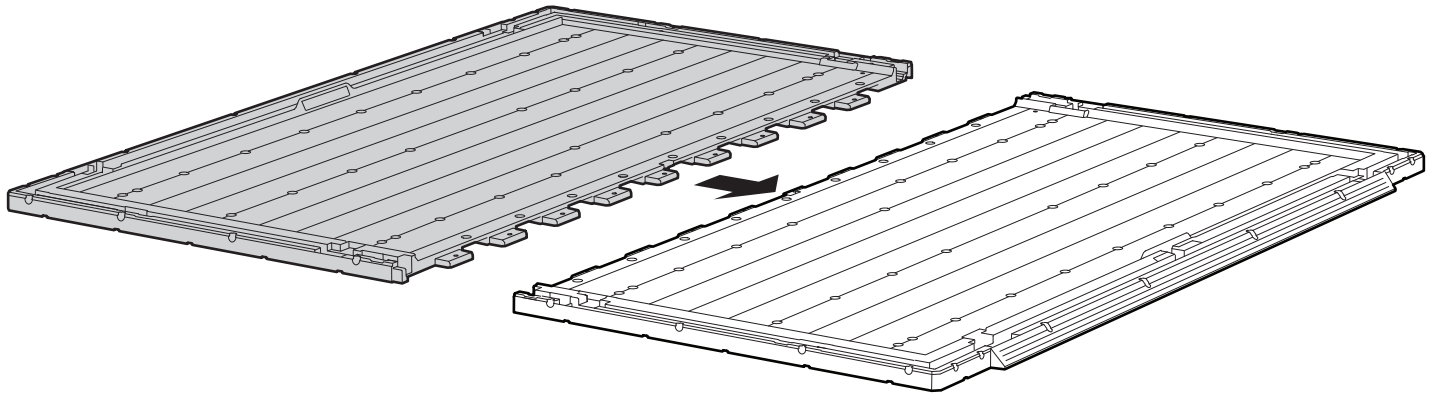

2

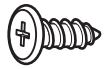

sc15 (x18)

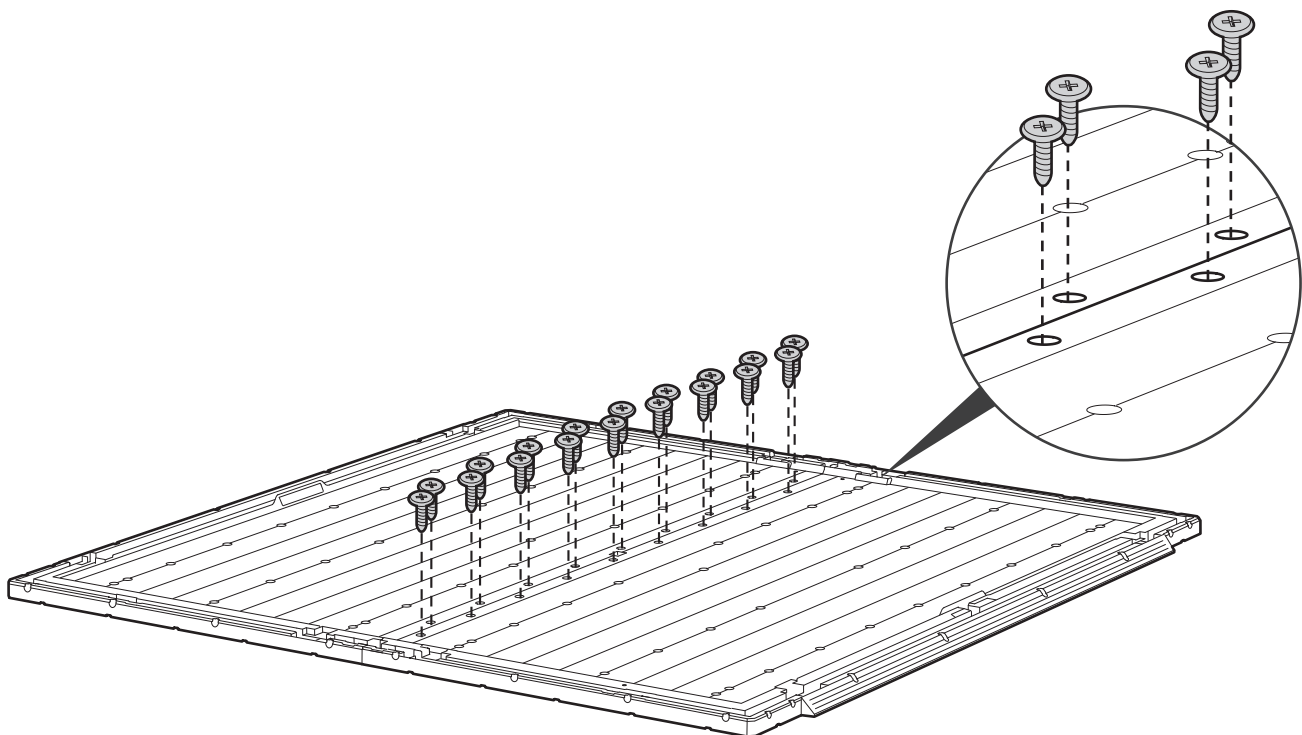

3



NEDSM (x1)

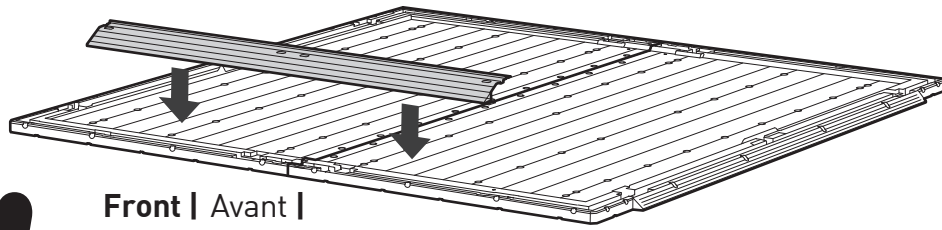

! **Front | Avant |
Delante | Vorderseite |
Voorkant | Anteriore
| Frente | 앞쪽**

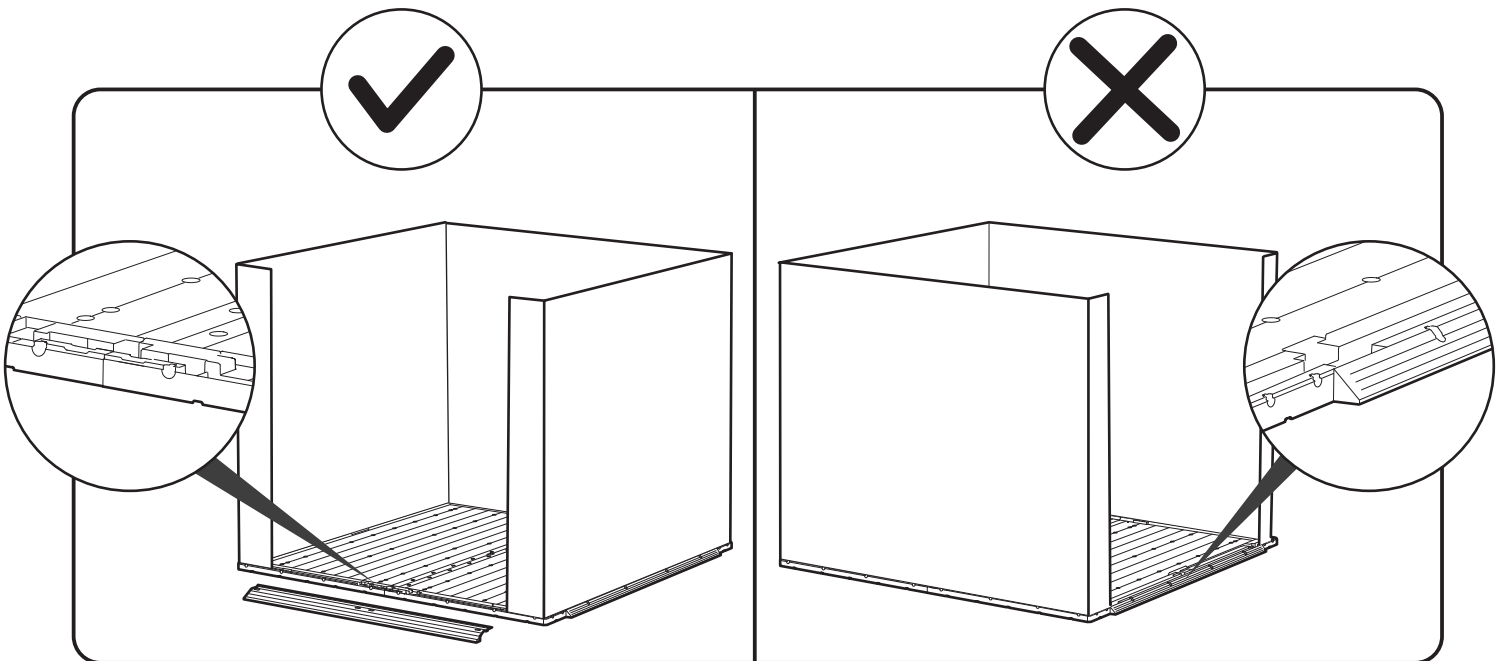
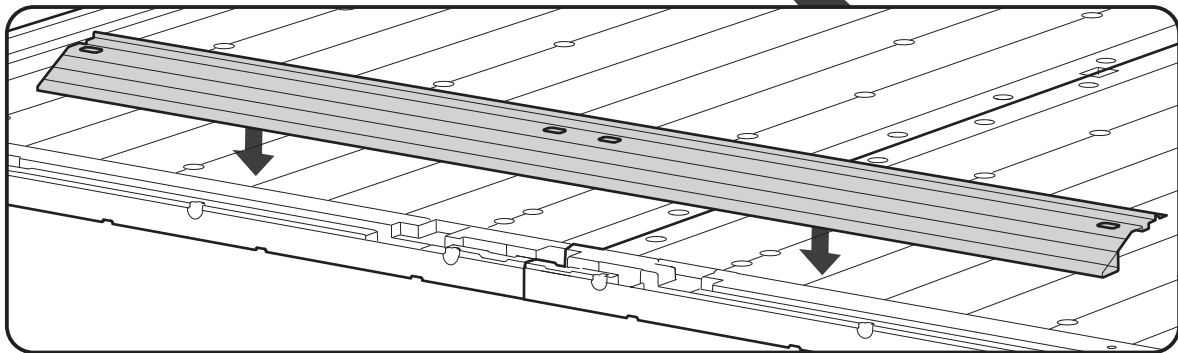

4

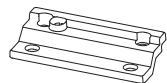

neDS (x1)



sc15 (x2)

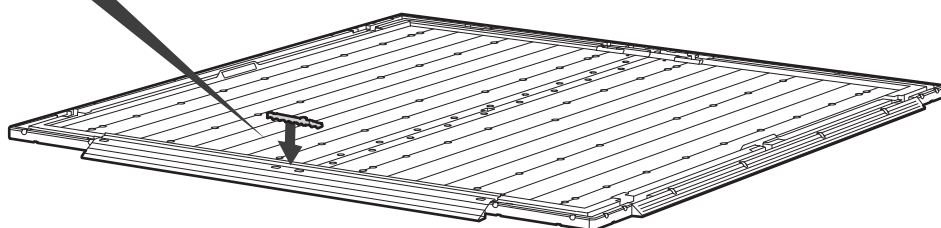
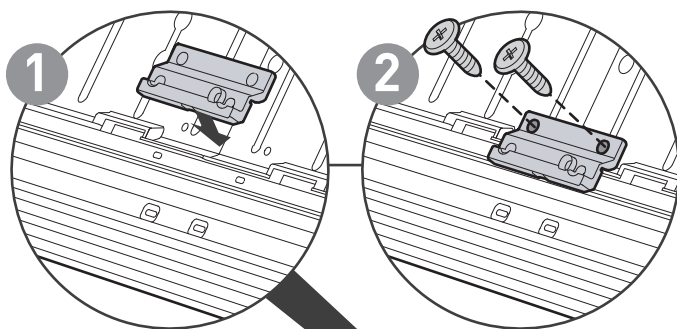

WALL ASSEMBLY | MONTAGE DU MUR | MONTAJE DE LAS PAREDES | MONTAGE DER WÄNDE | MONTAGE VAN DE MUREN | ASSEMBLAGGIO DELLE PARETI | MONTAGEM DA PAREDE

5



ncPB7 (x3)



ncDF (x2)

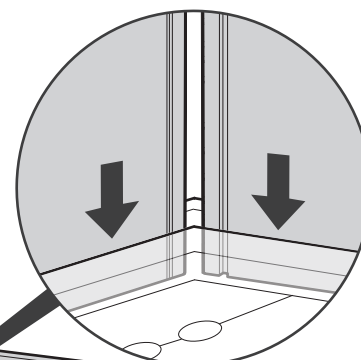
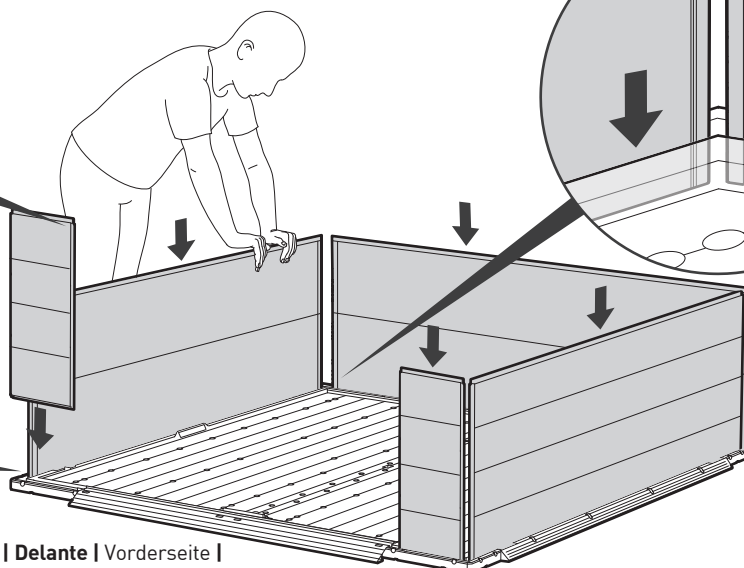
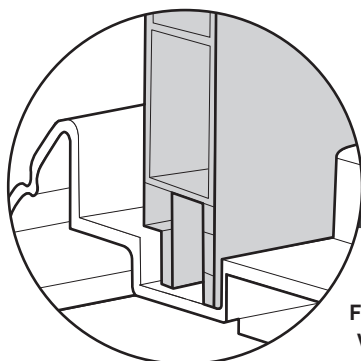
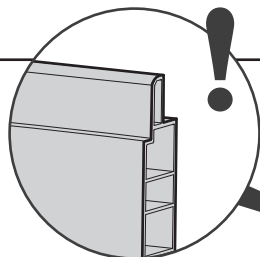
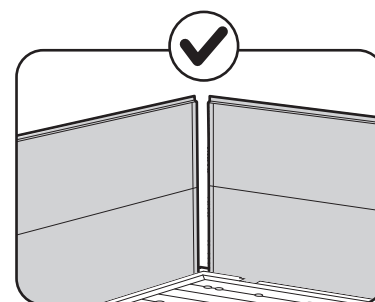
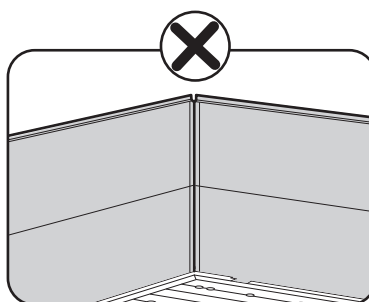
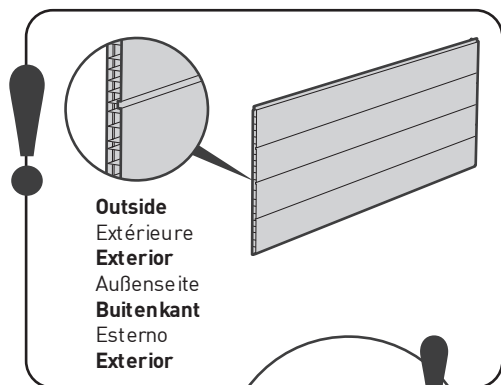

Front | Avant | Delante | Vorderseite | Voorkant | Anteriore | Frente | 앞쪽

6

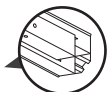
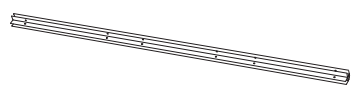

NECO (x4)

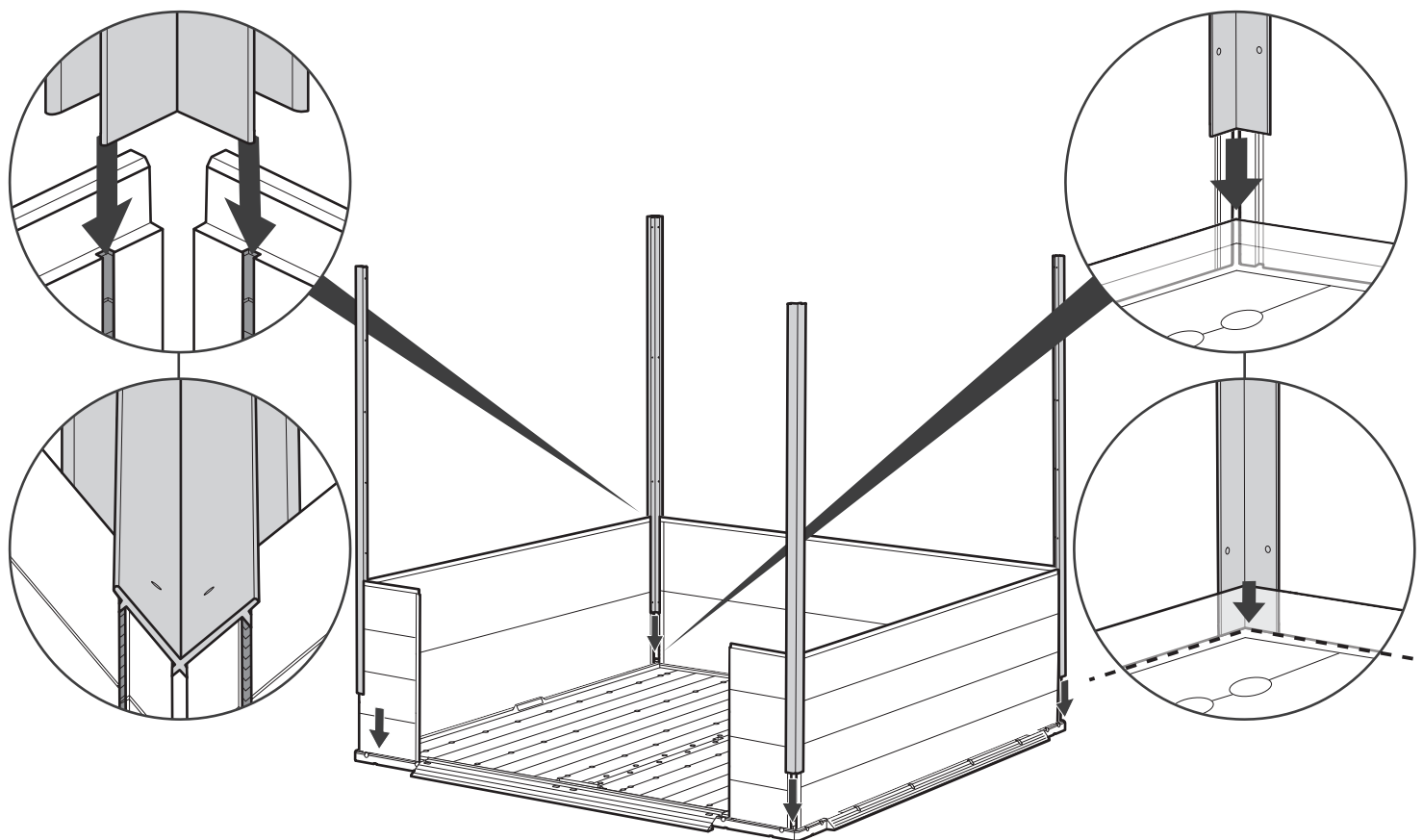

7



s13b (x8)

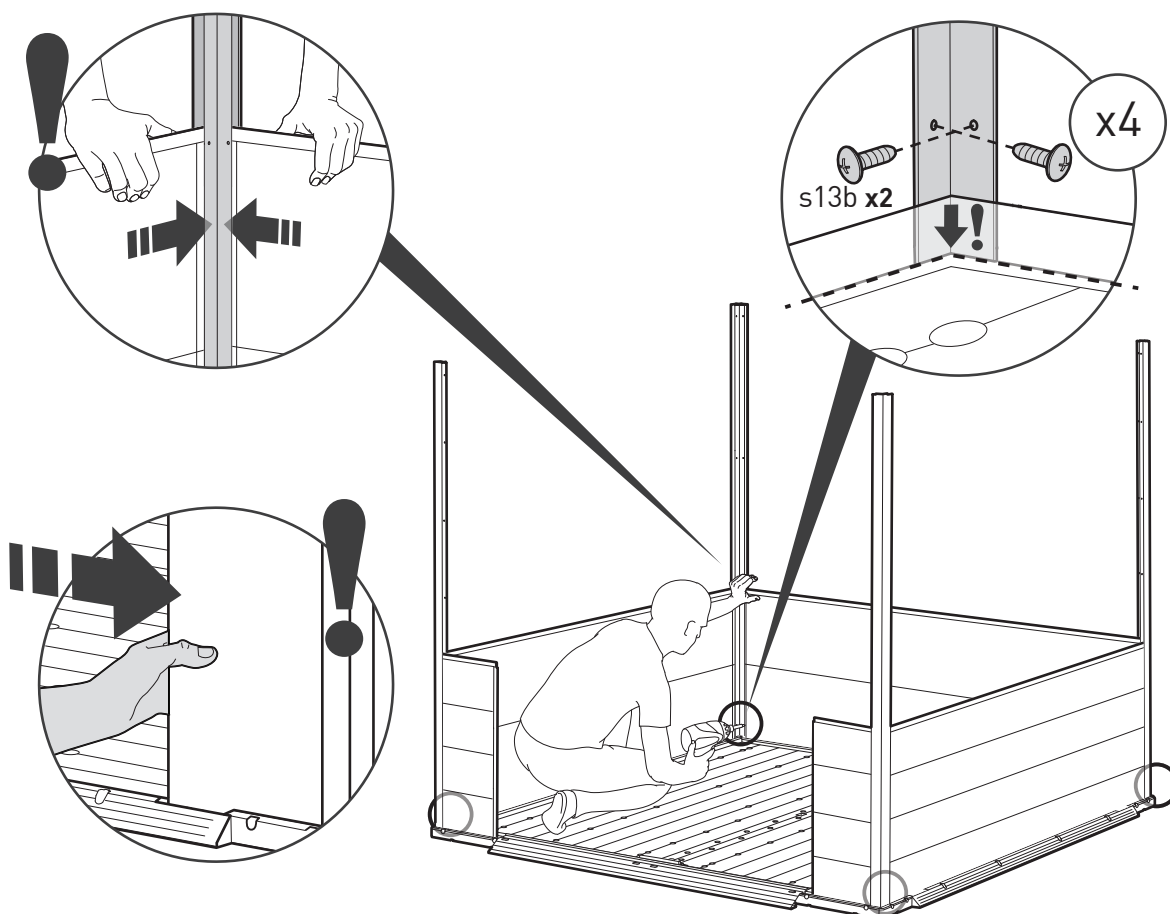

8



ncPB7 (x3)



ncDF (x2)

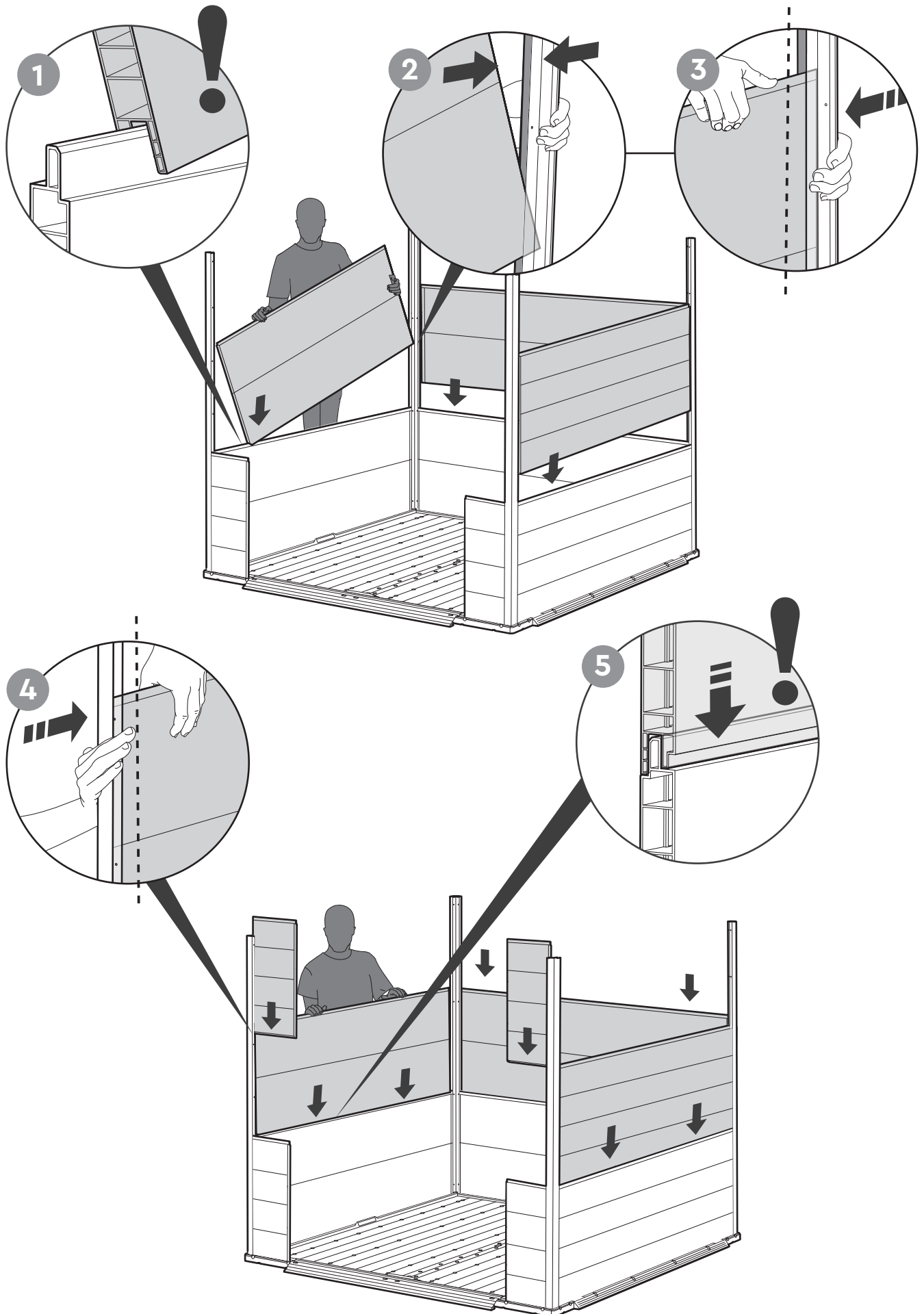

9



s13b (x8)

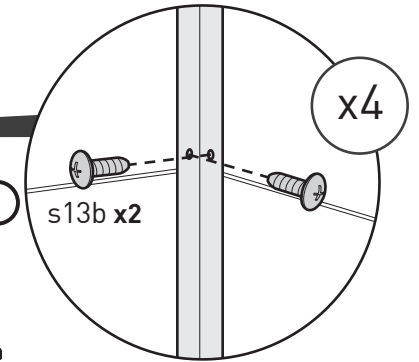
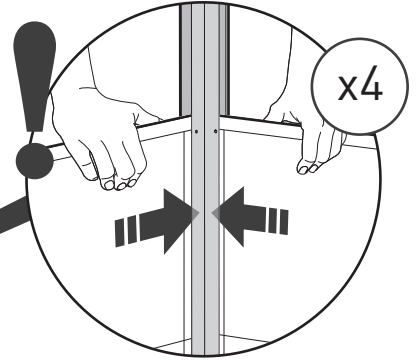
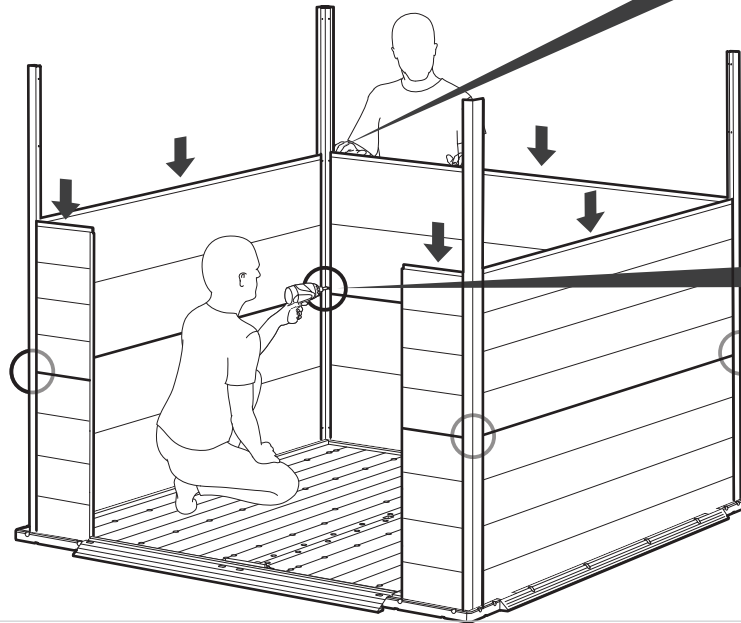
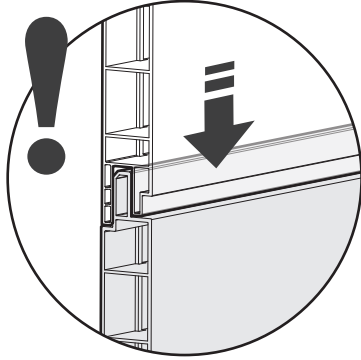
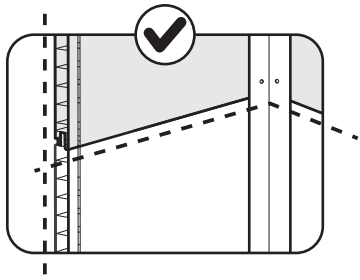
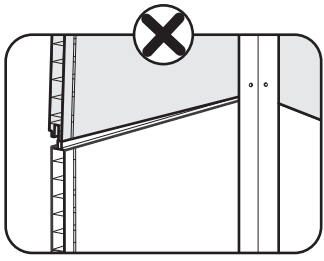

10



ncPB7 (x3)



ncDF (x2)

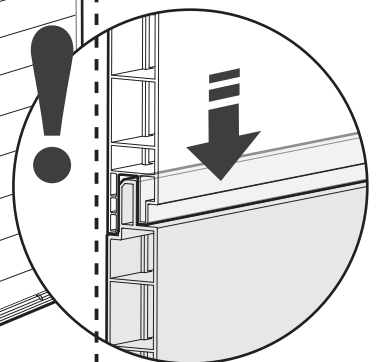
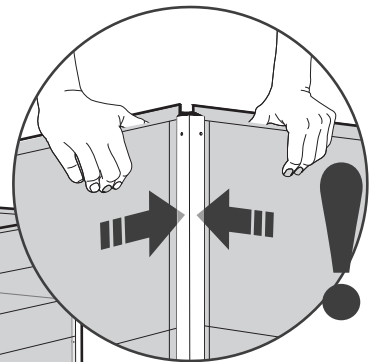
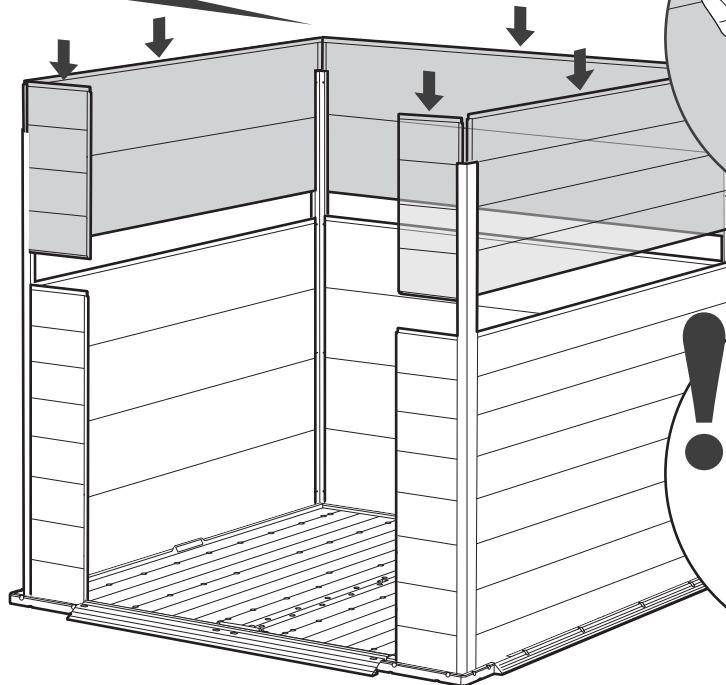
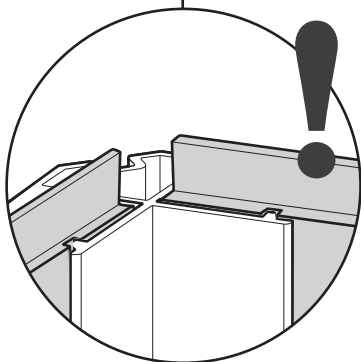
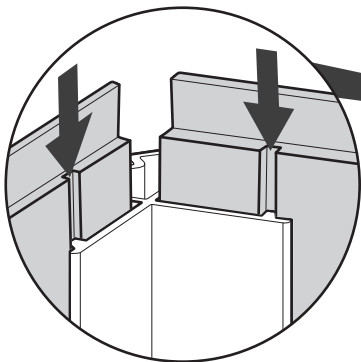

11

s13b (x16)

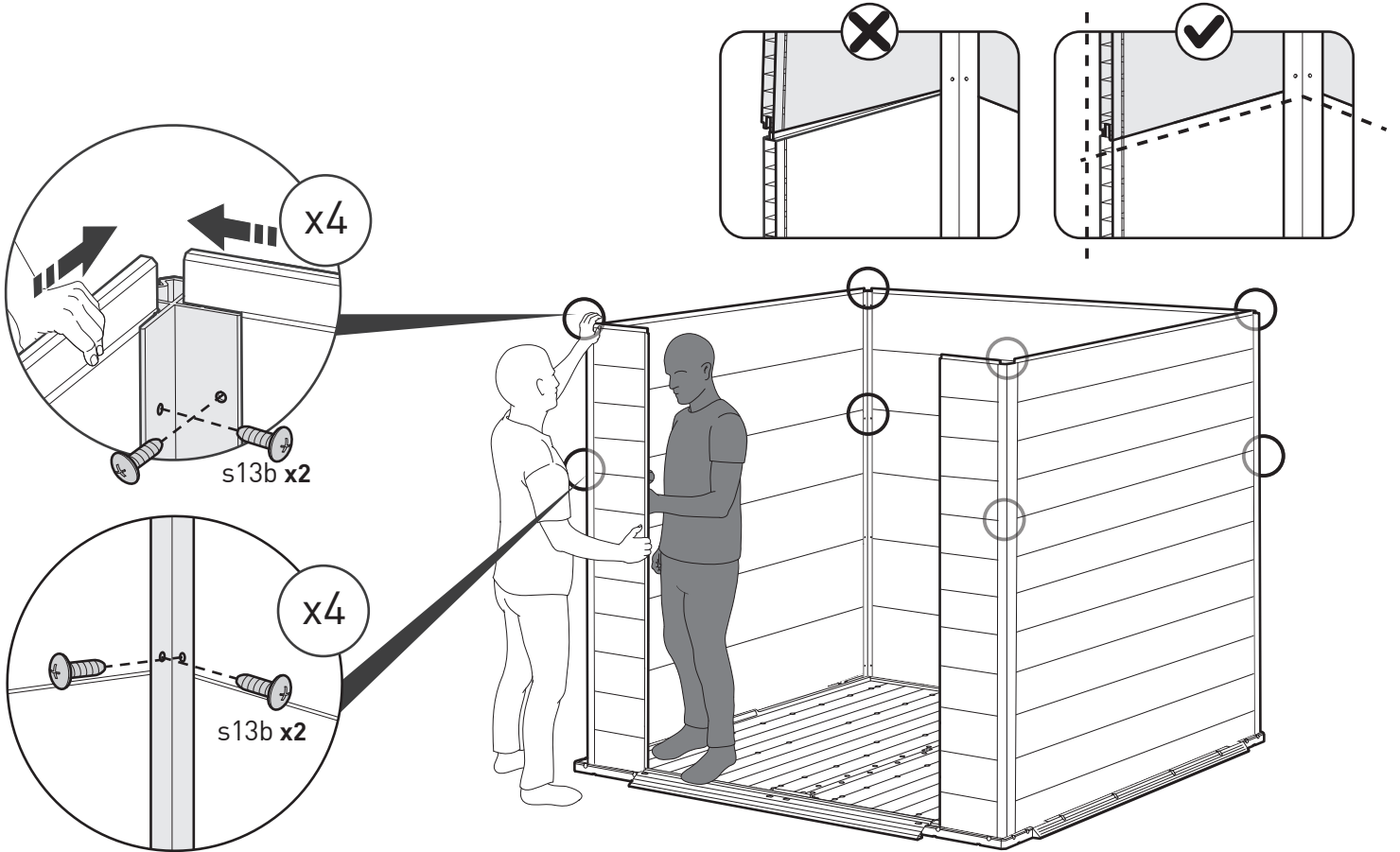

12

S45b (x26)

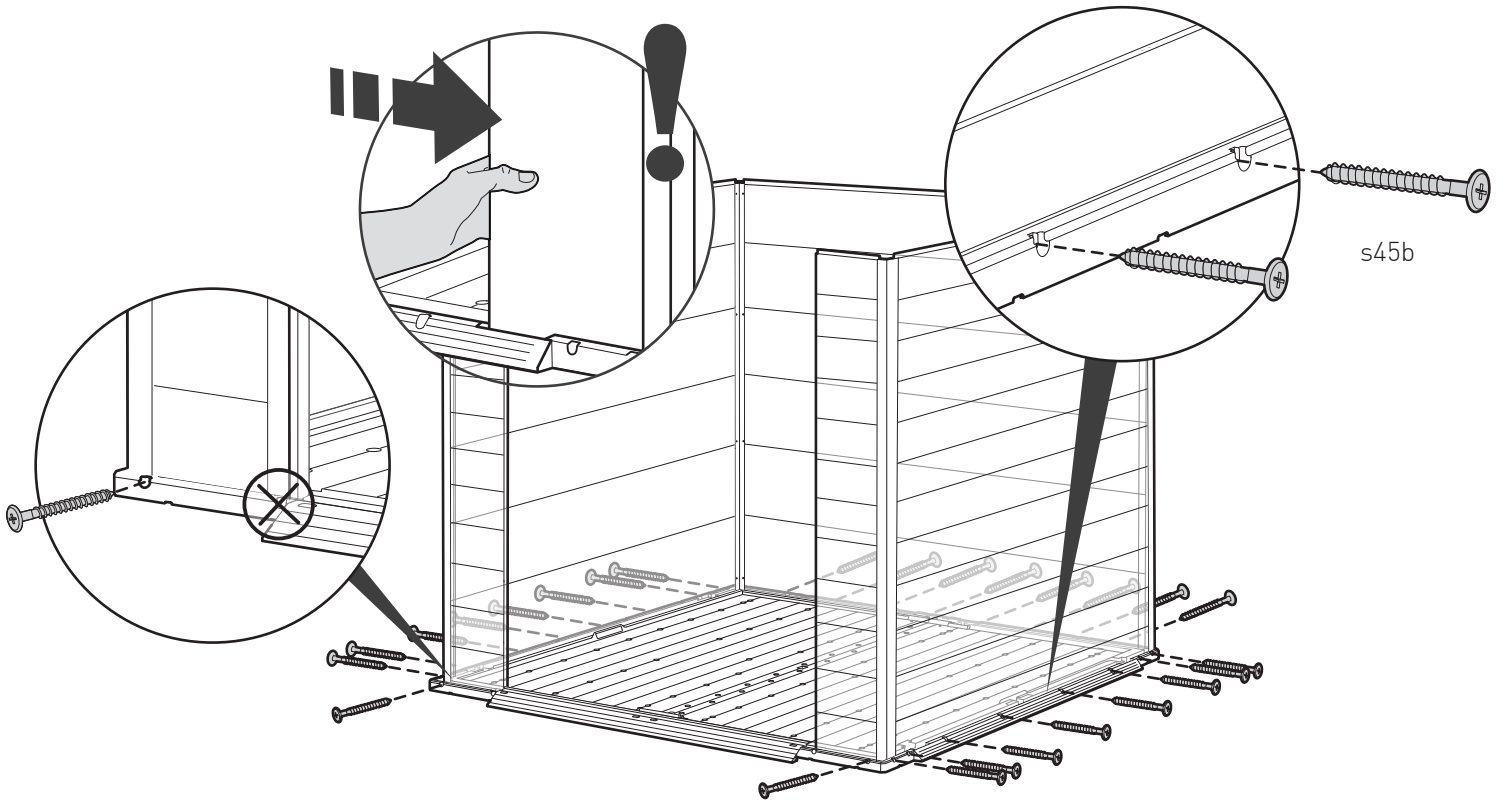

13

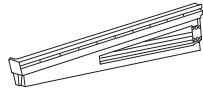

NEBLT (x1)

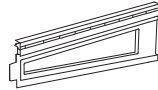

NELT (x1)



sc15 (x5)

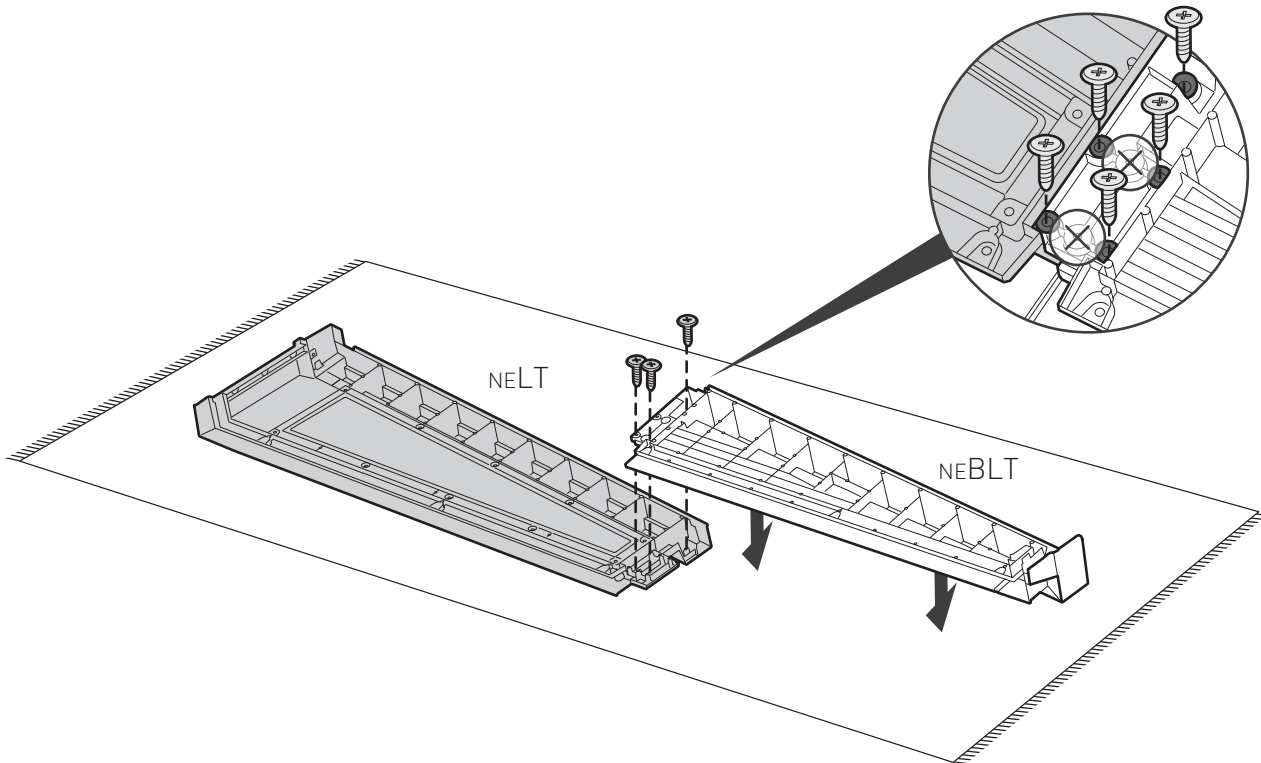

14

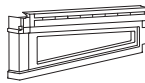

NERT (x1)

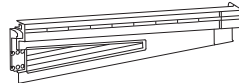

NEBRT (x1)



sc15 (x5)

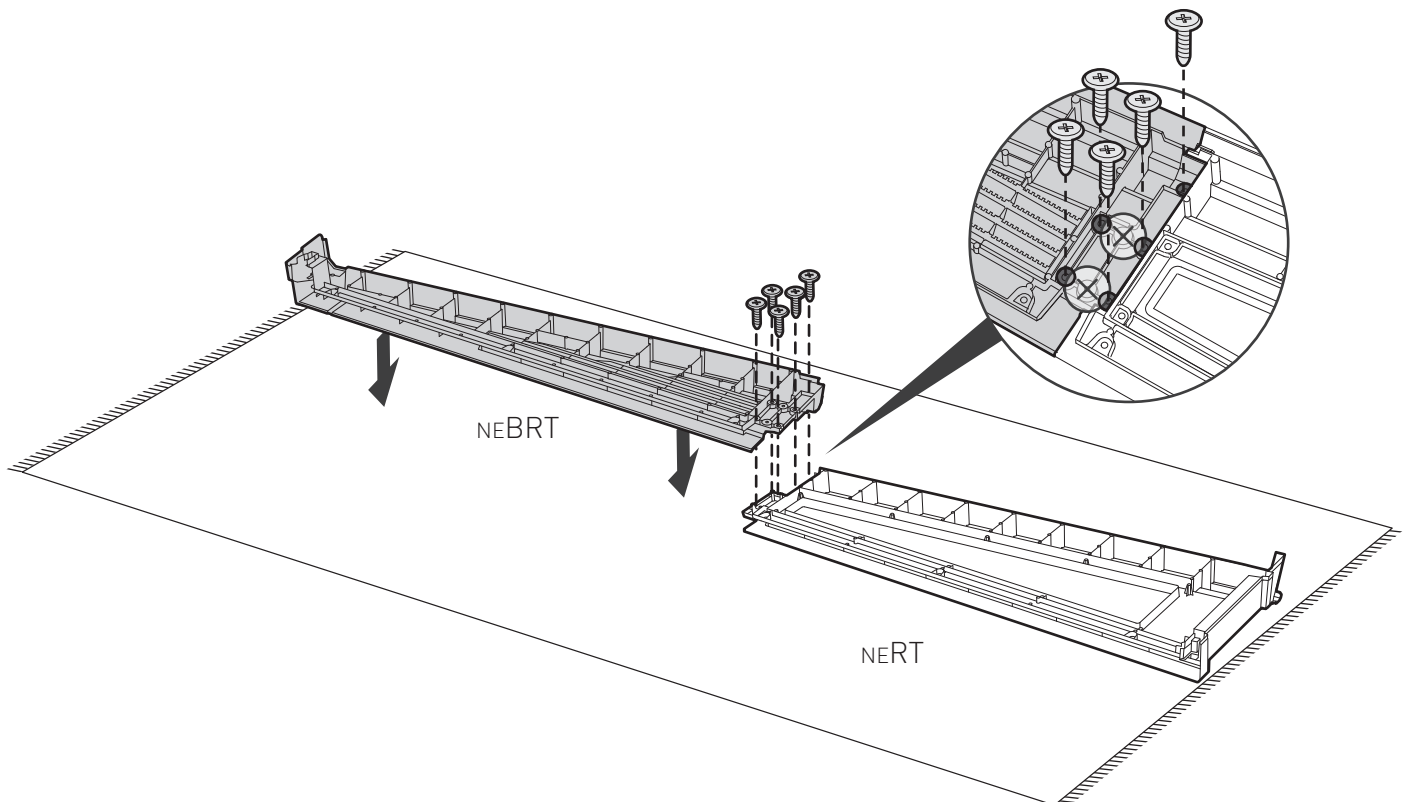

15

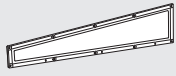

NEG T (x1)

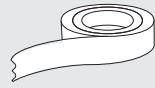

NEPL

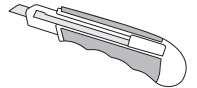

Right | Droit | **Derecho** | Richtig
Rechts | Destra | **Direito** | 오른쪽

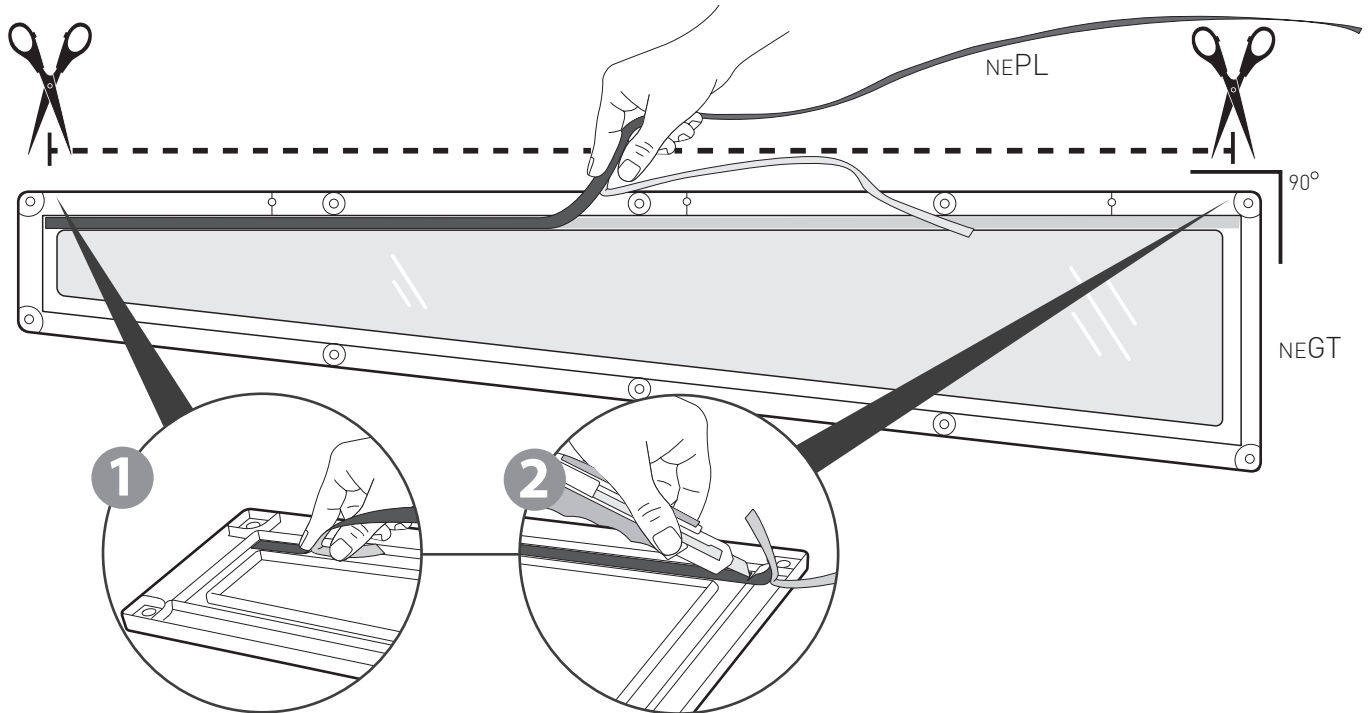
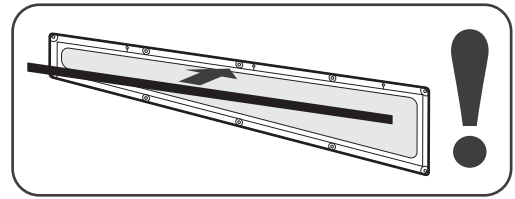

16

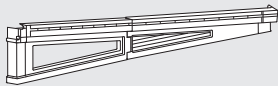

NEBRT + NERT

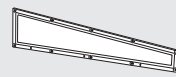

NEPL + NEG T



sc15 (x10)

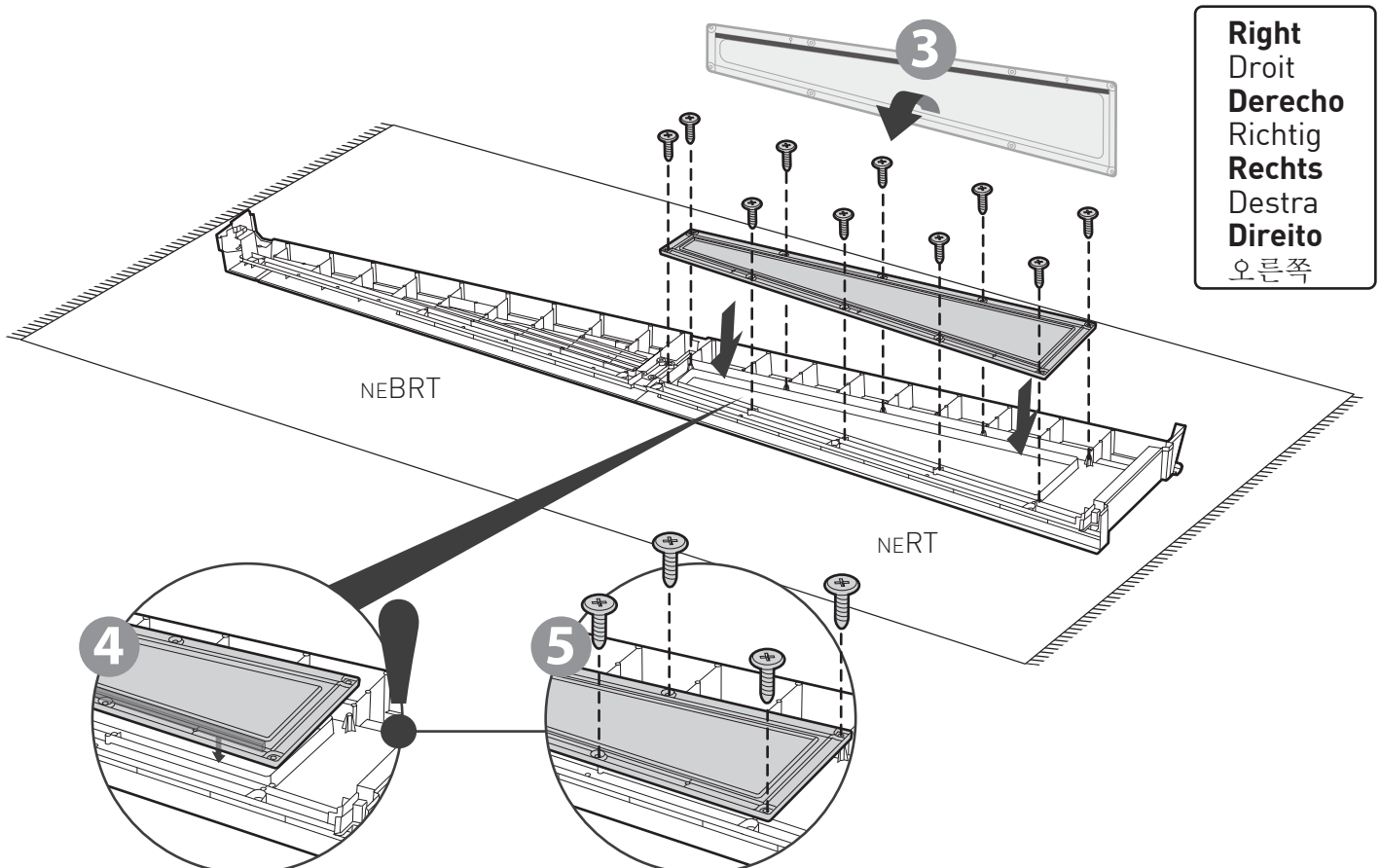

Right
Droit
Derecho
Richtig
Rechts
Destra
Direito
오른쪽

17

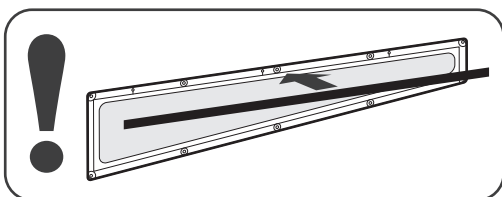
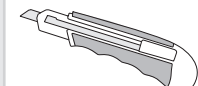
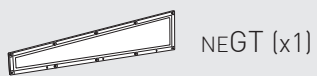

Left | Gauche | Izquierdo | Verließ
| Links | Sinistra | esquermo | 왼쪽

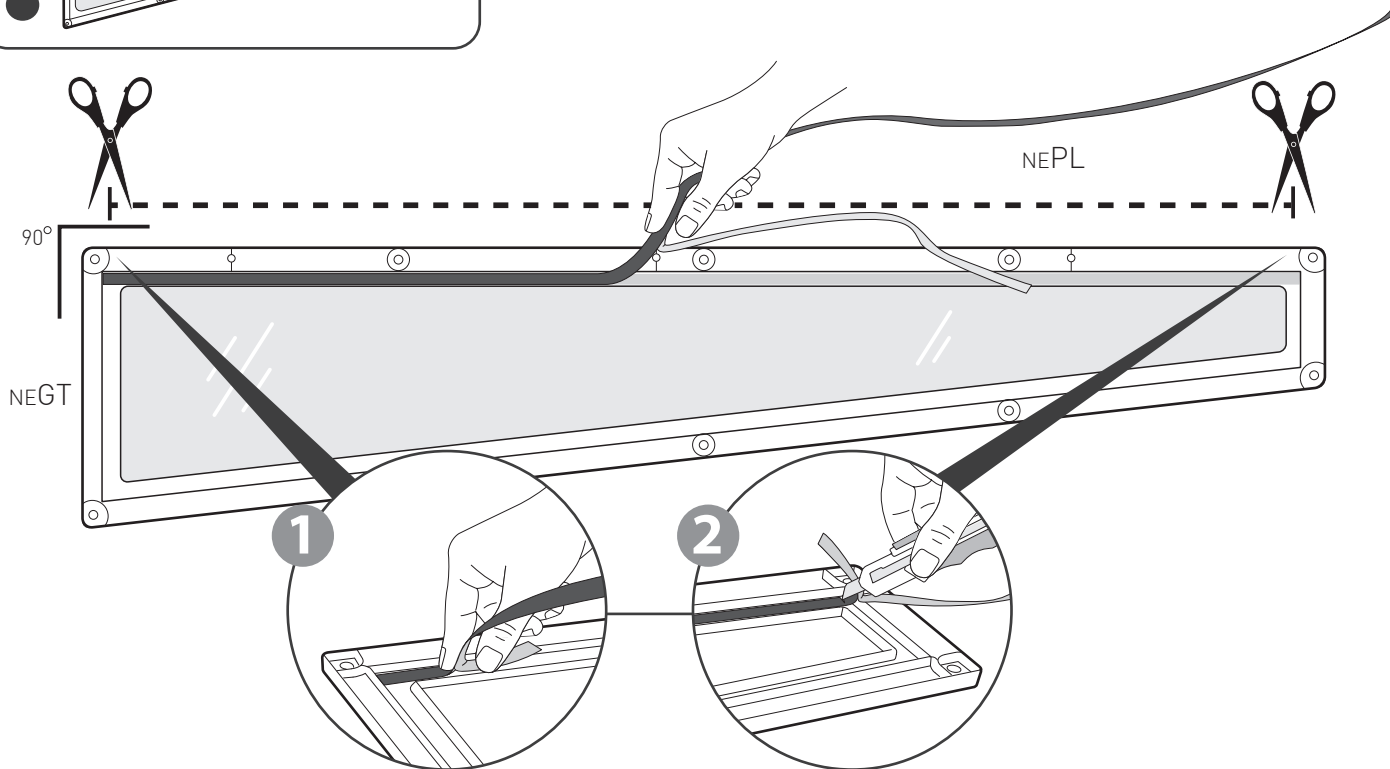

18

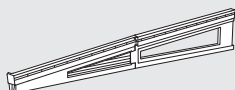

NELT + NEBLT

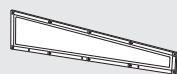

NEPL + NEGT



sc15 (x10)

Left
Gauche
Izquierdo
Verließ
Links
Sinistra
esquermo
왼쪽

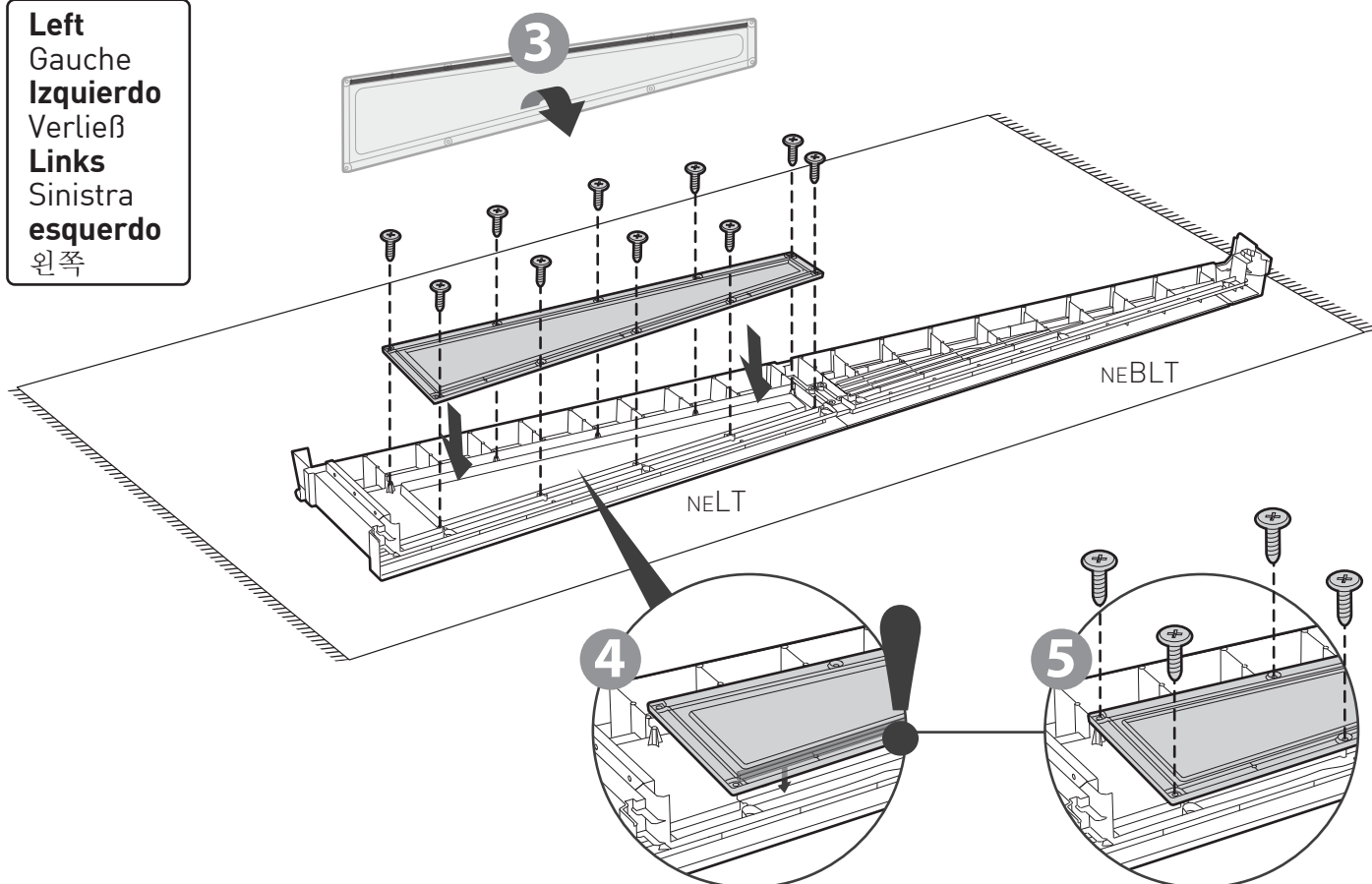

19

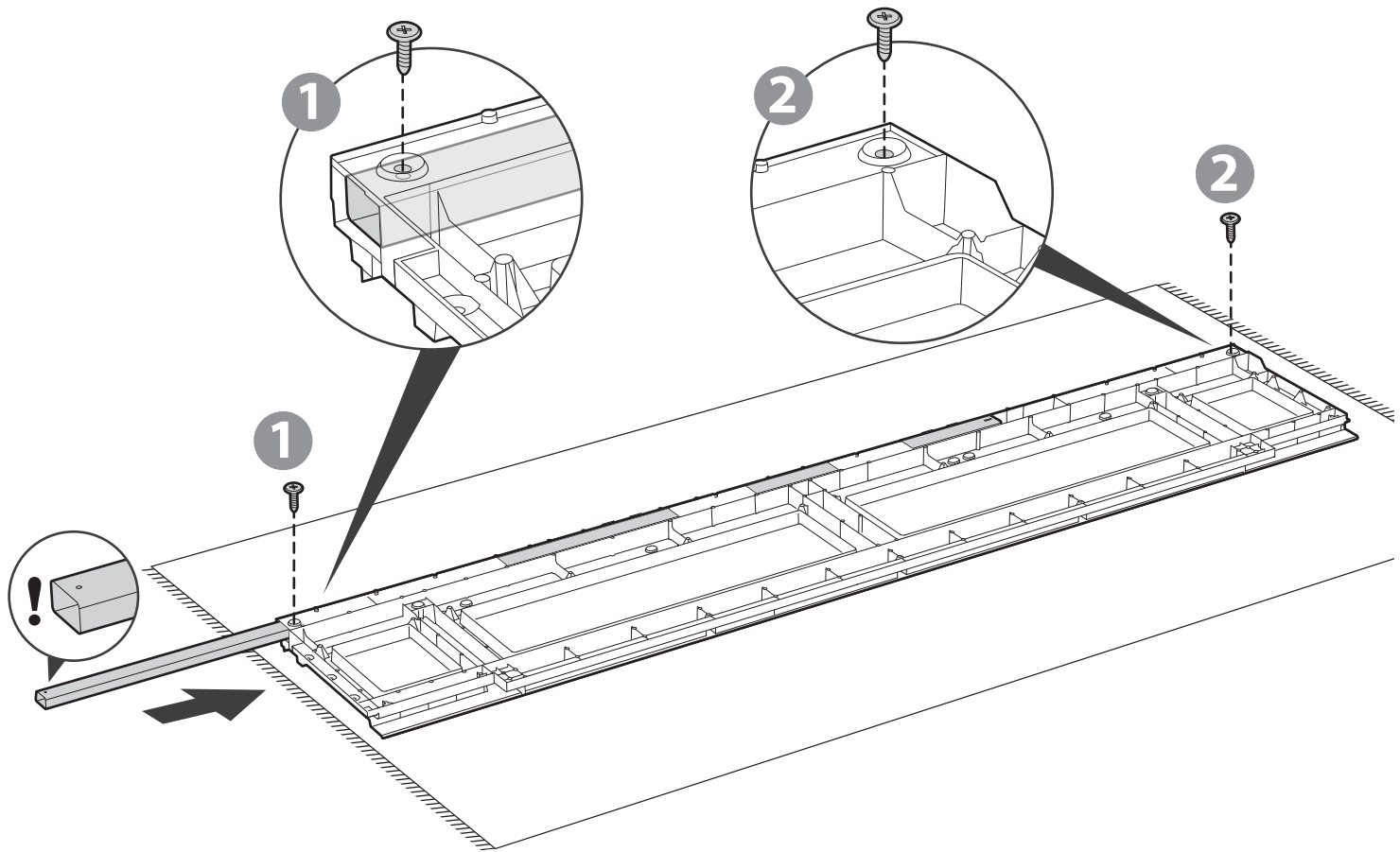
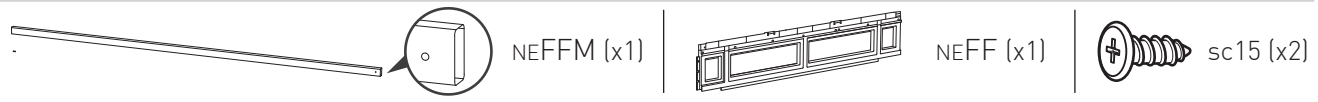

20

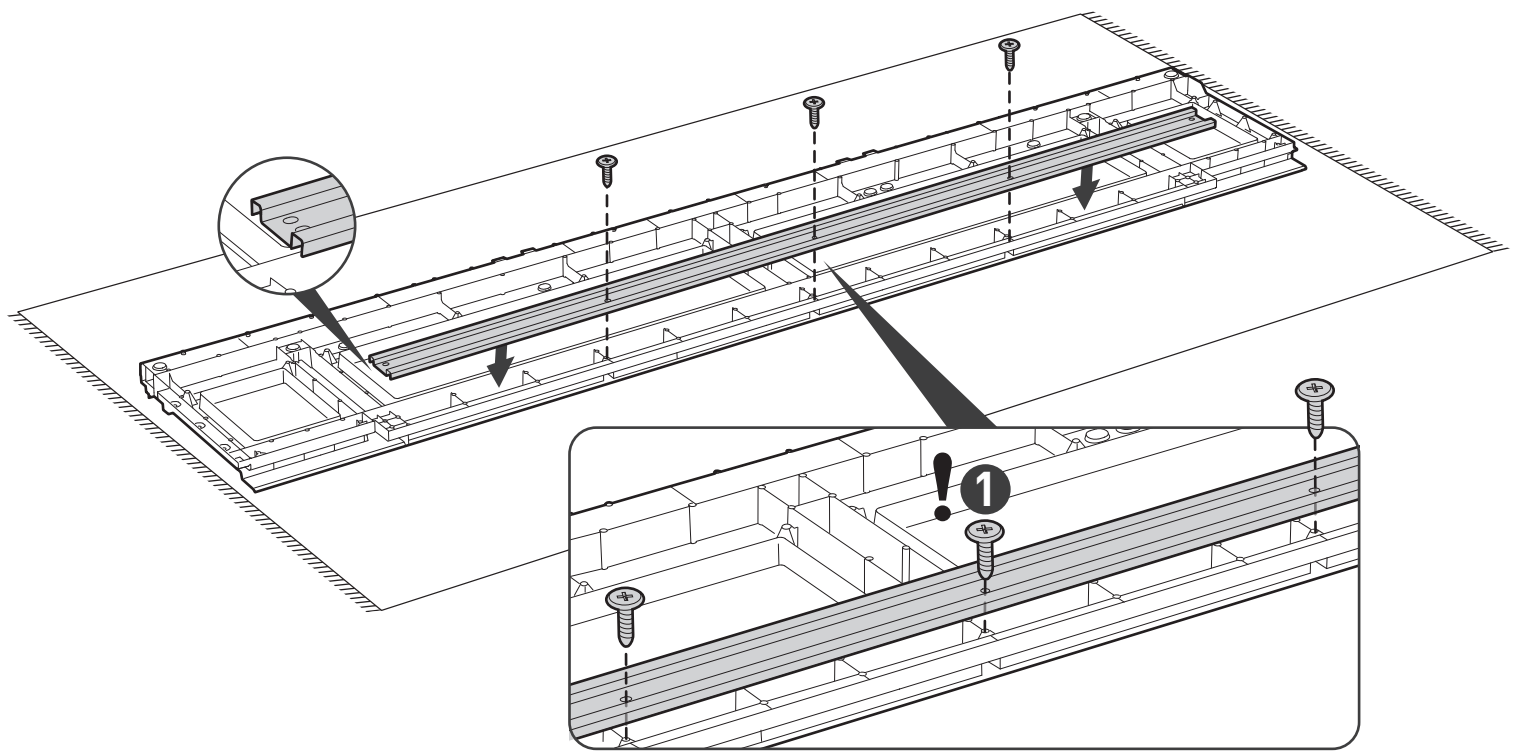

21

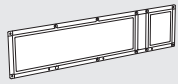

NEGR (x2)

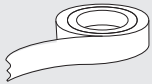

NEPL

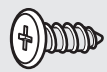

sc15 (x24)

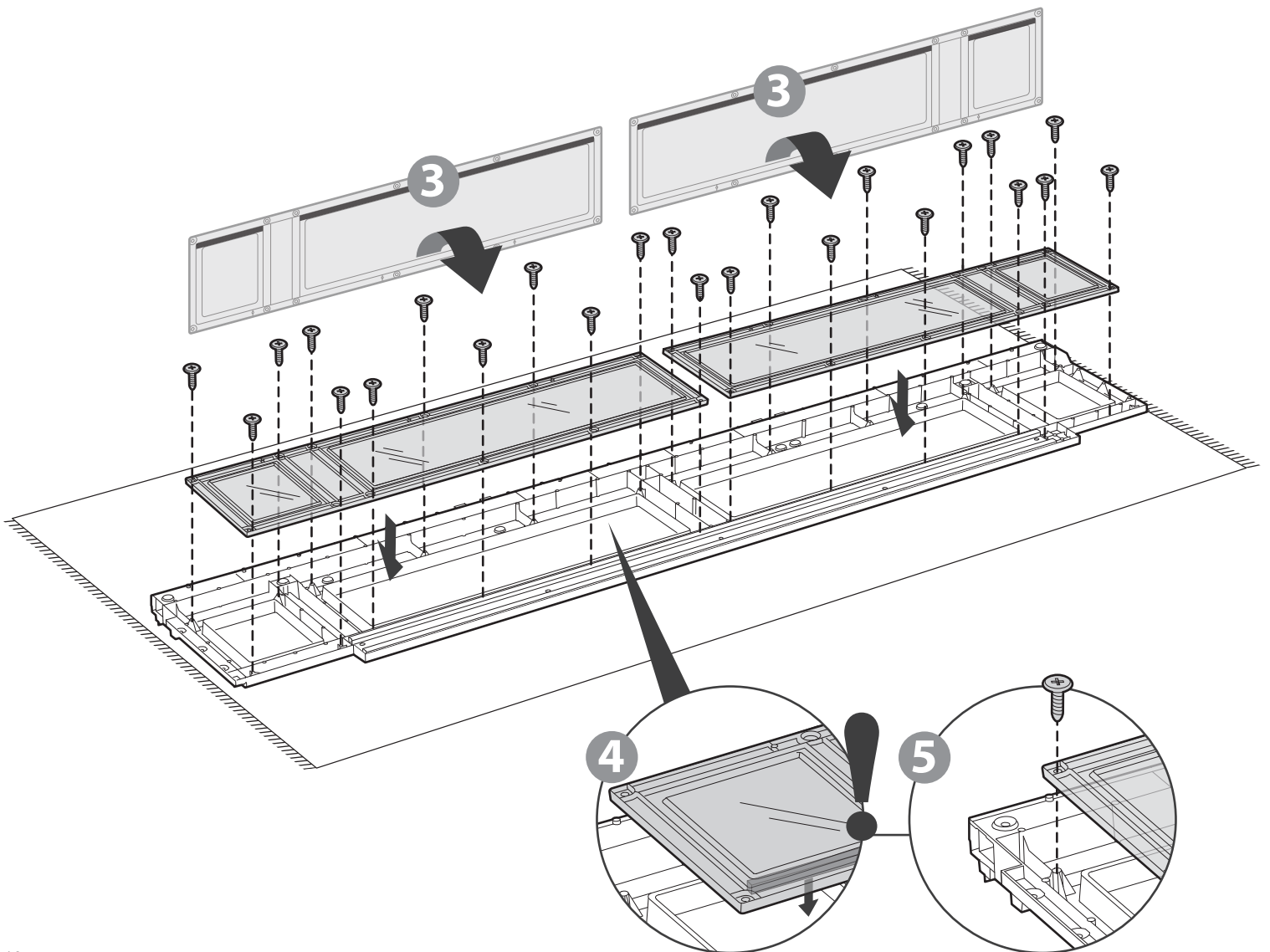
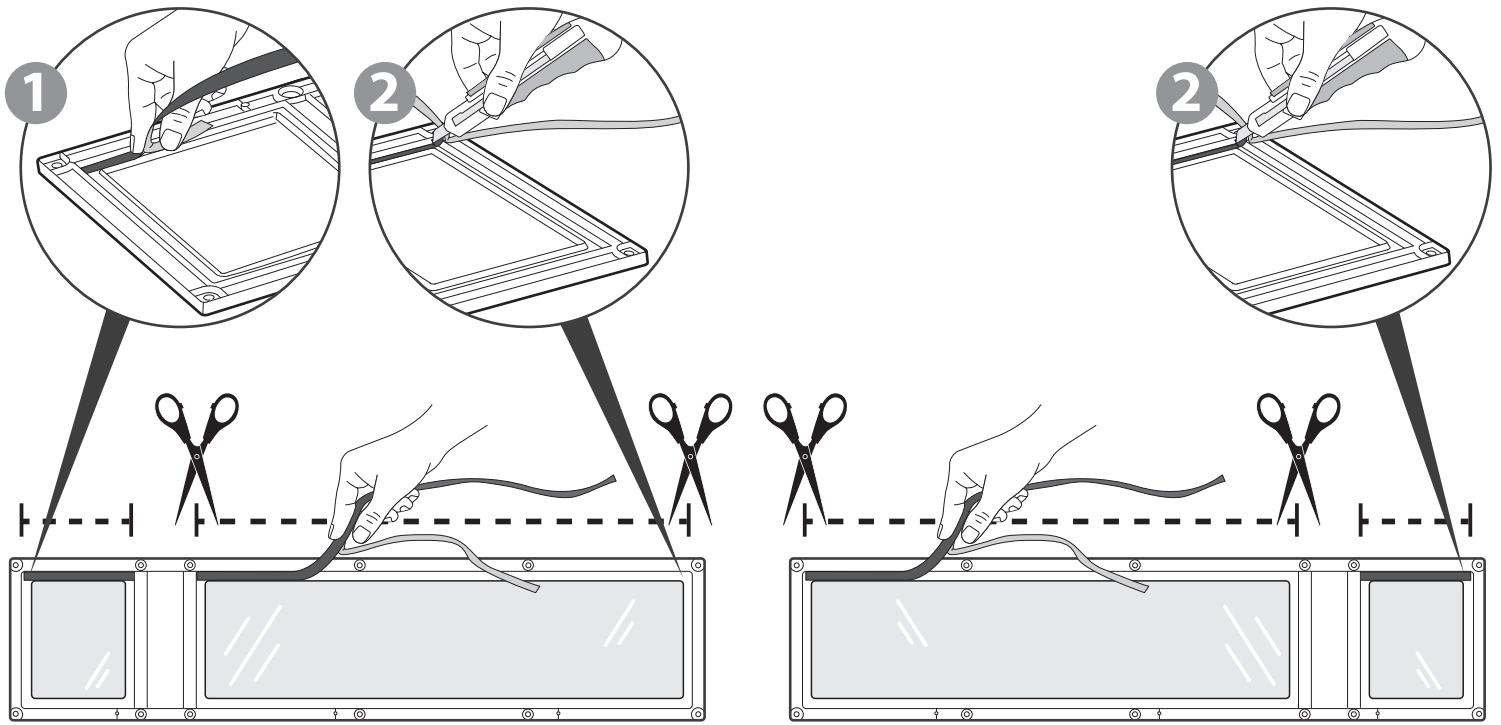
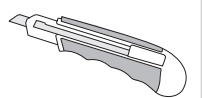

22

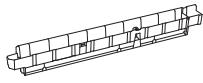

nELD (x1)

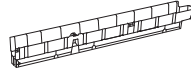

nERD (x1)



sc15 (x2)

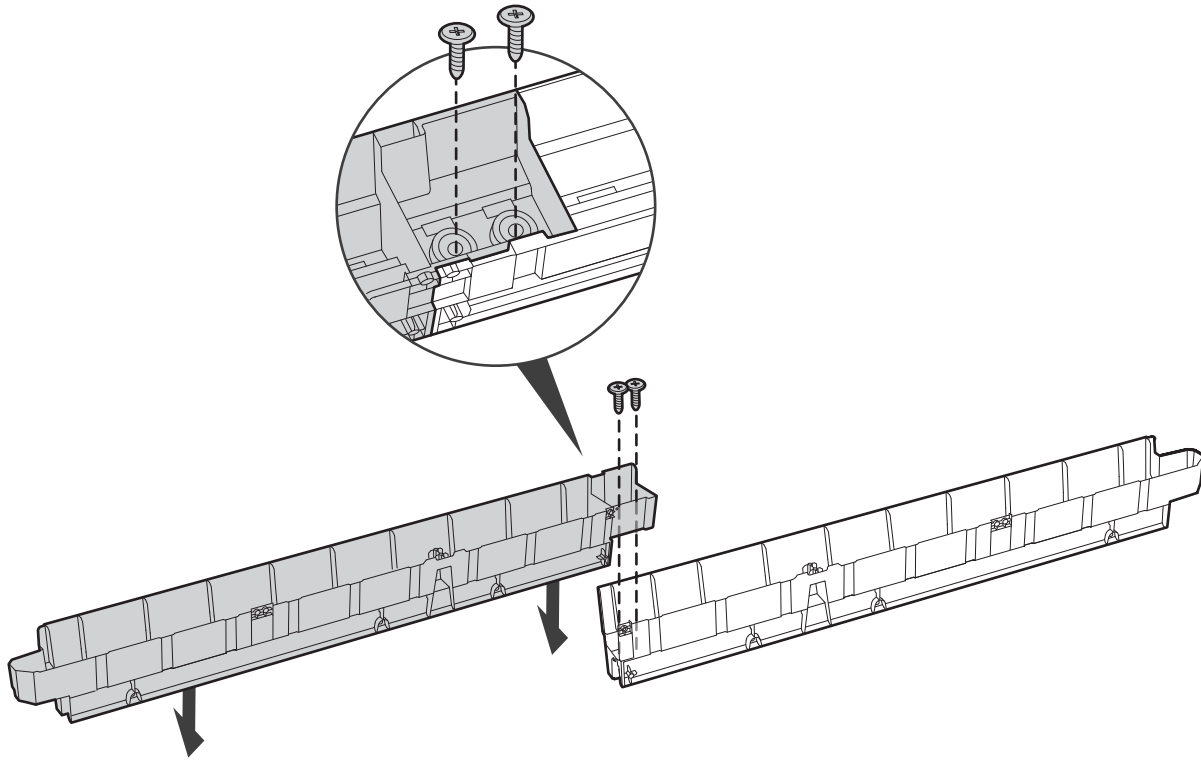

23

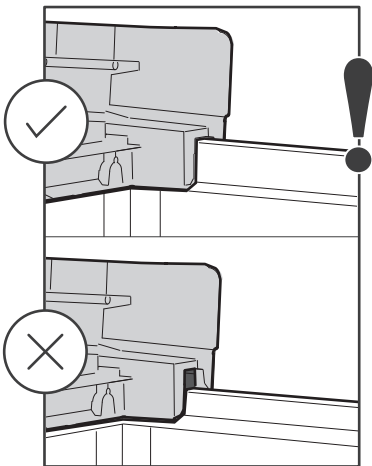
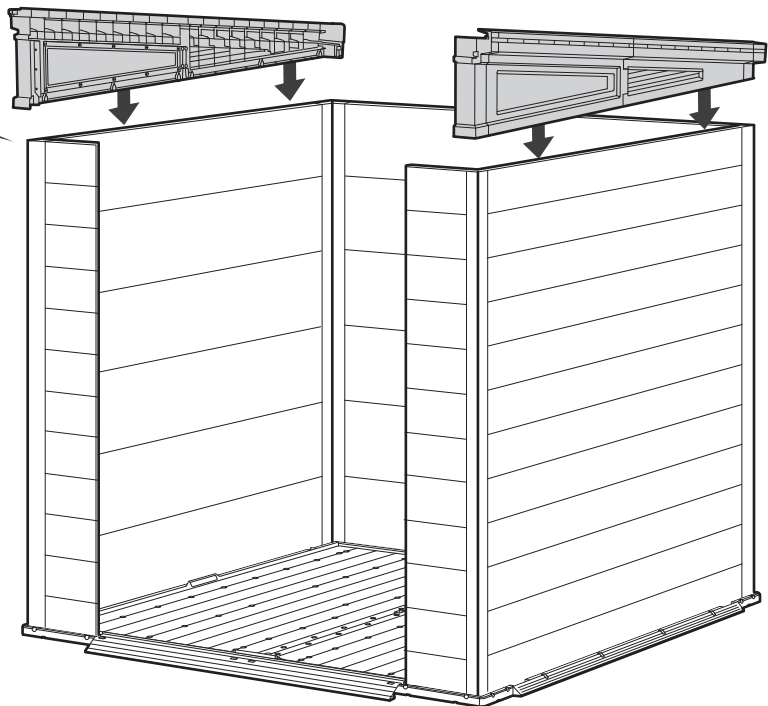
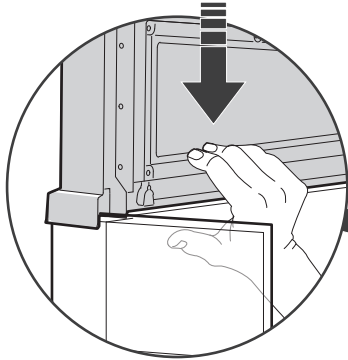
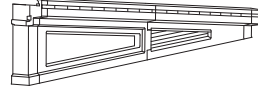
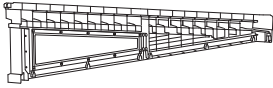

24

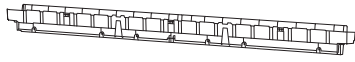

NELD + NERD (x1)



sc15 (x2)

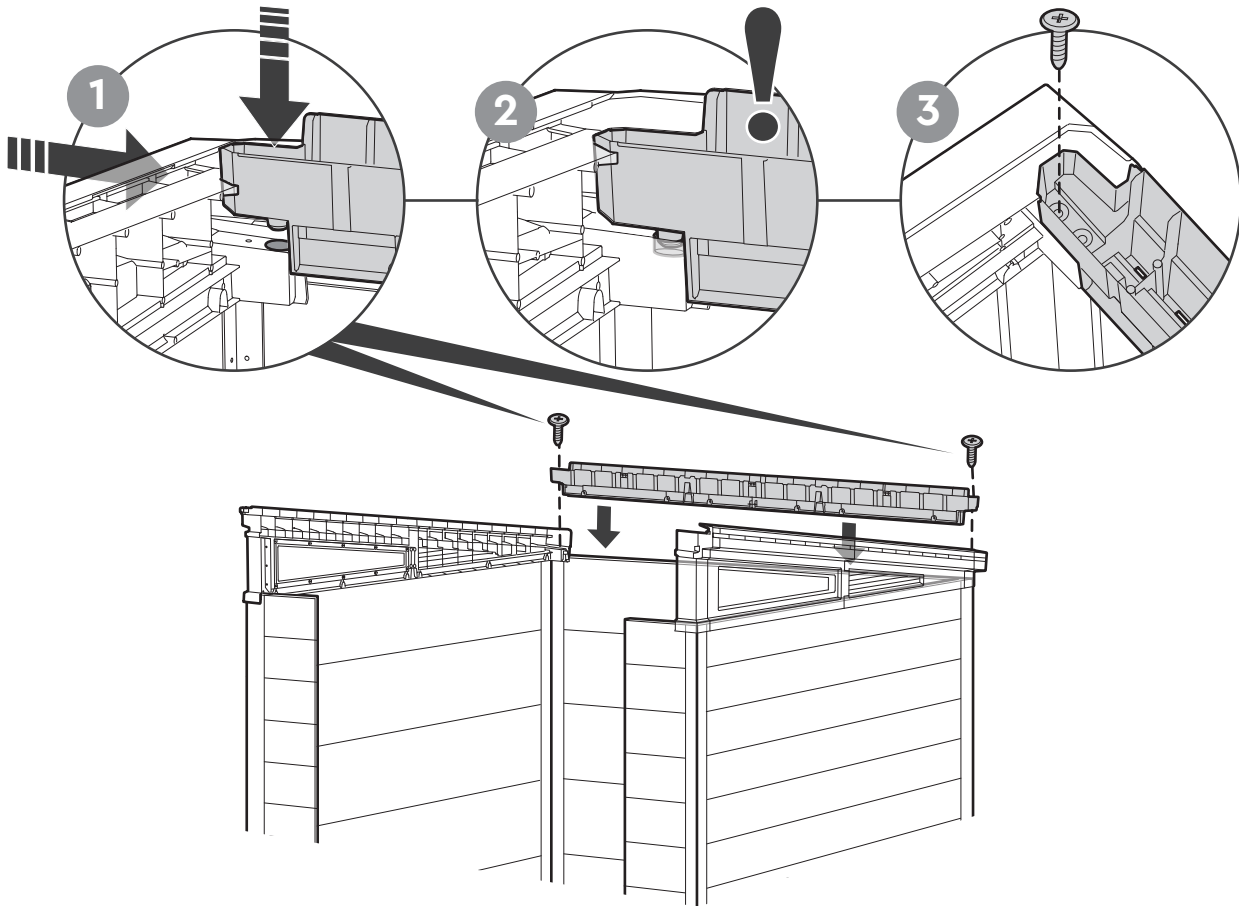

25

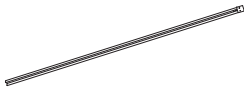

NEBPM (x1)



sc15 (x2)

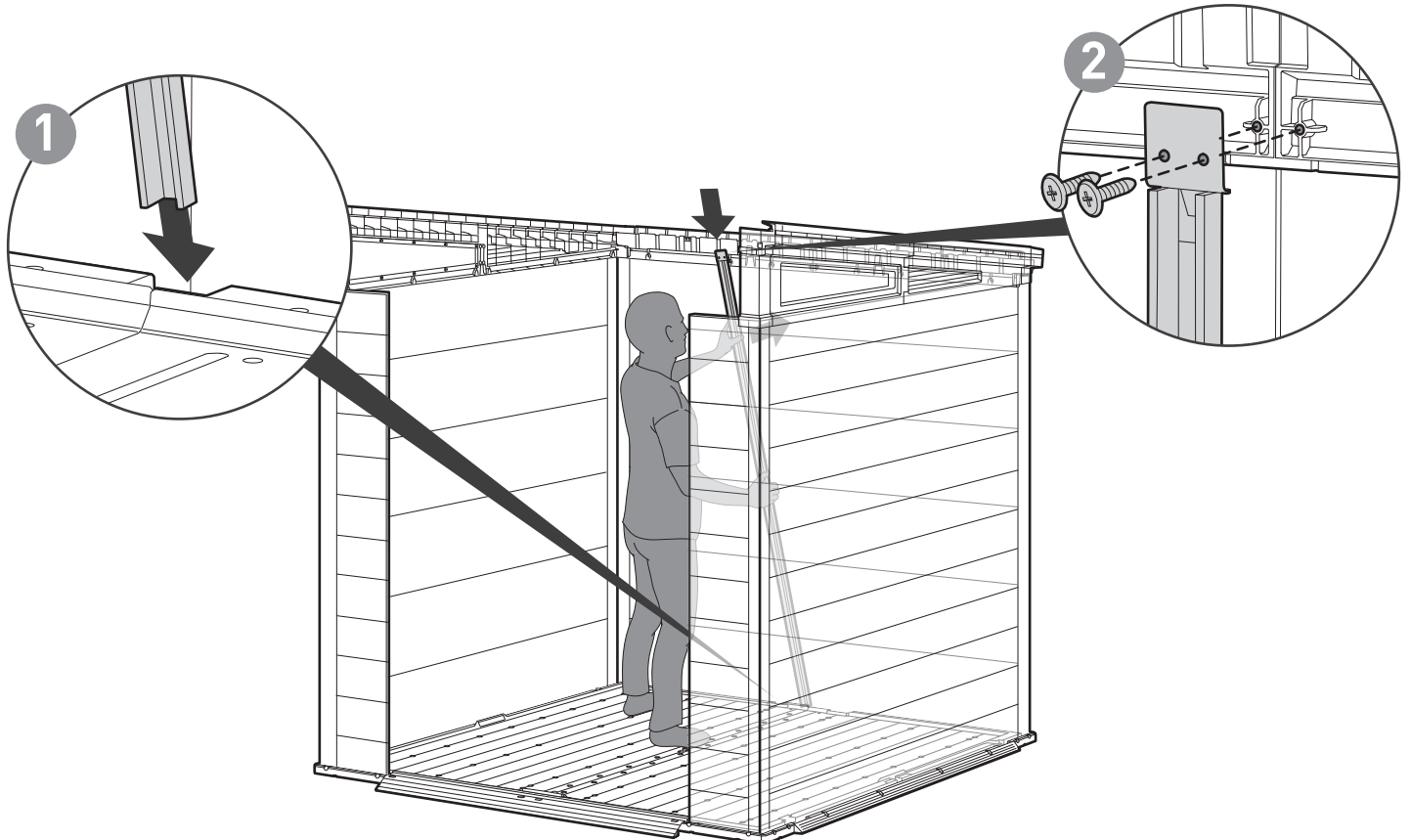

26



NESPM (x1)

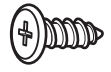

sc15 (x2)

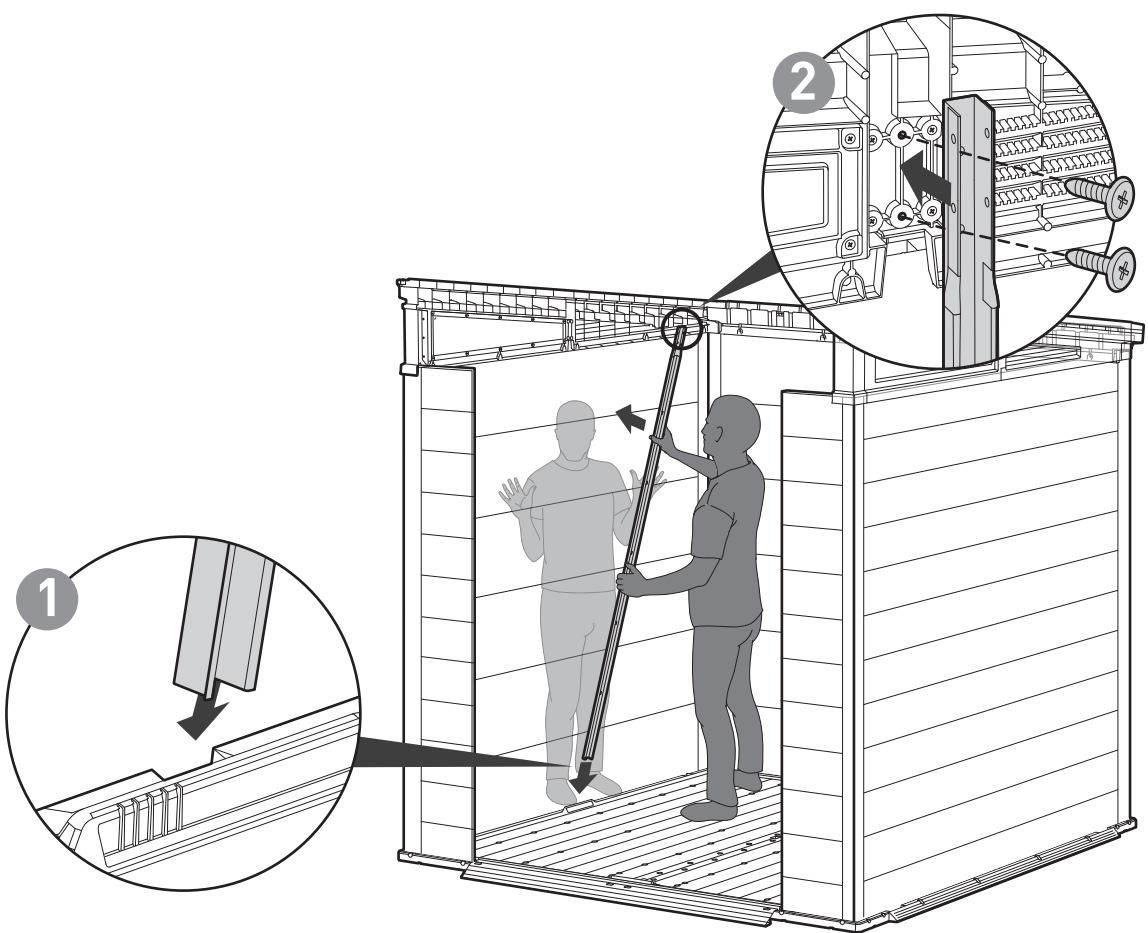

27



NESPM (x1)



sc15 (x2)

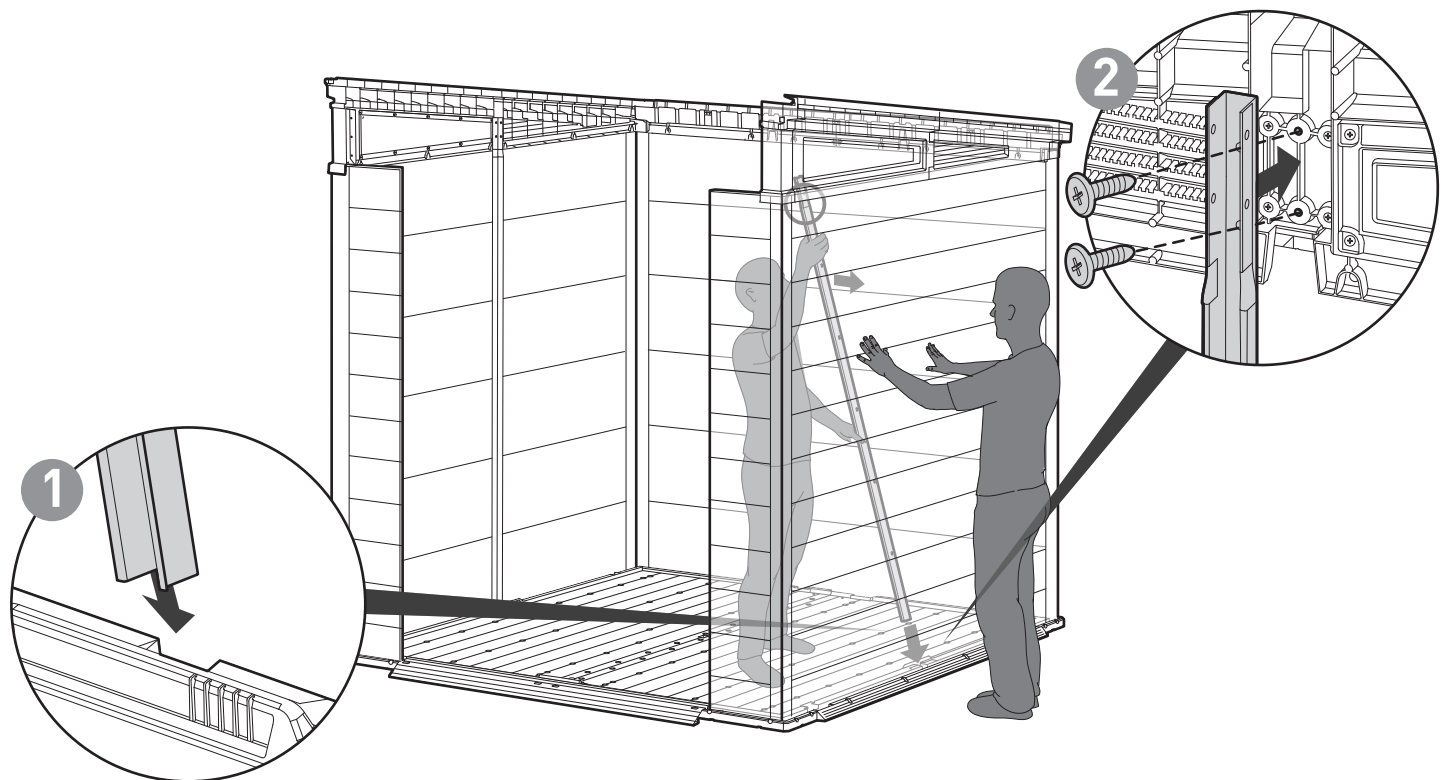

28



NESPC (x2)



sc8 (x4)

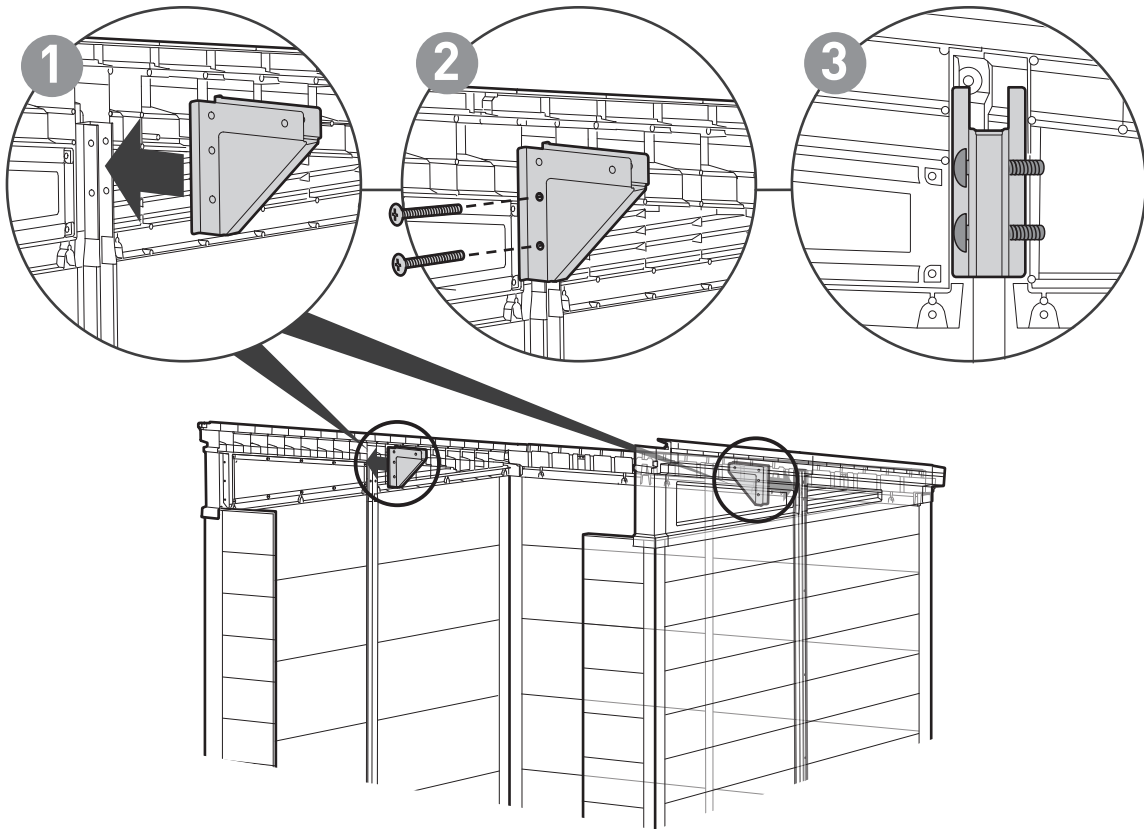

29



NERB7 (x1)

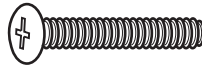

sc8 (x4)



scn8 (x8)

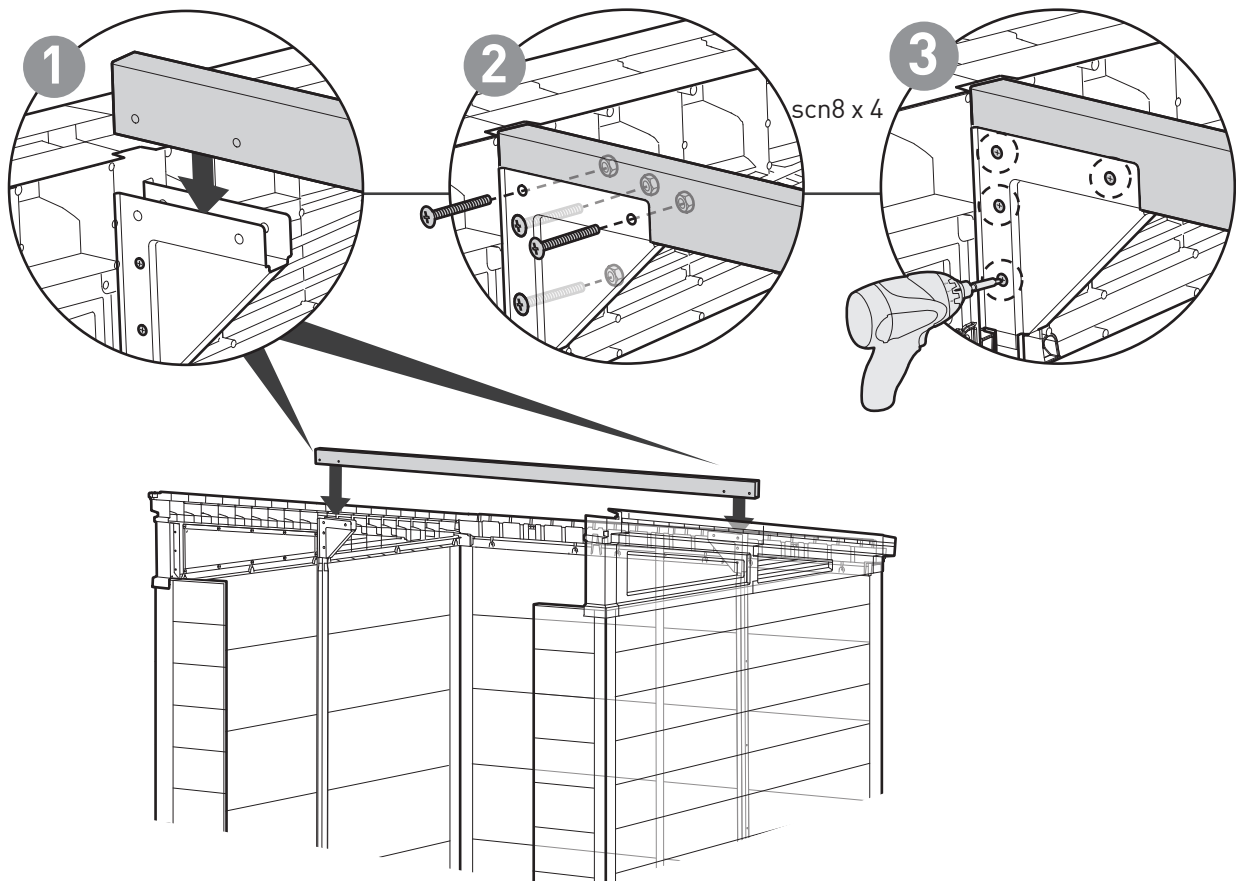

30

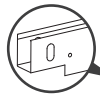

NELDAP (x1)



NERDP (x1)

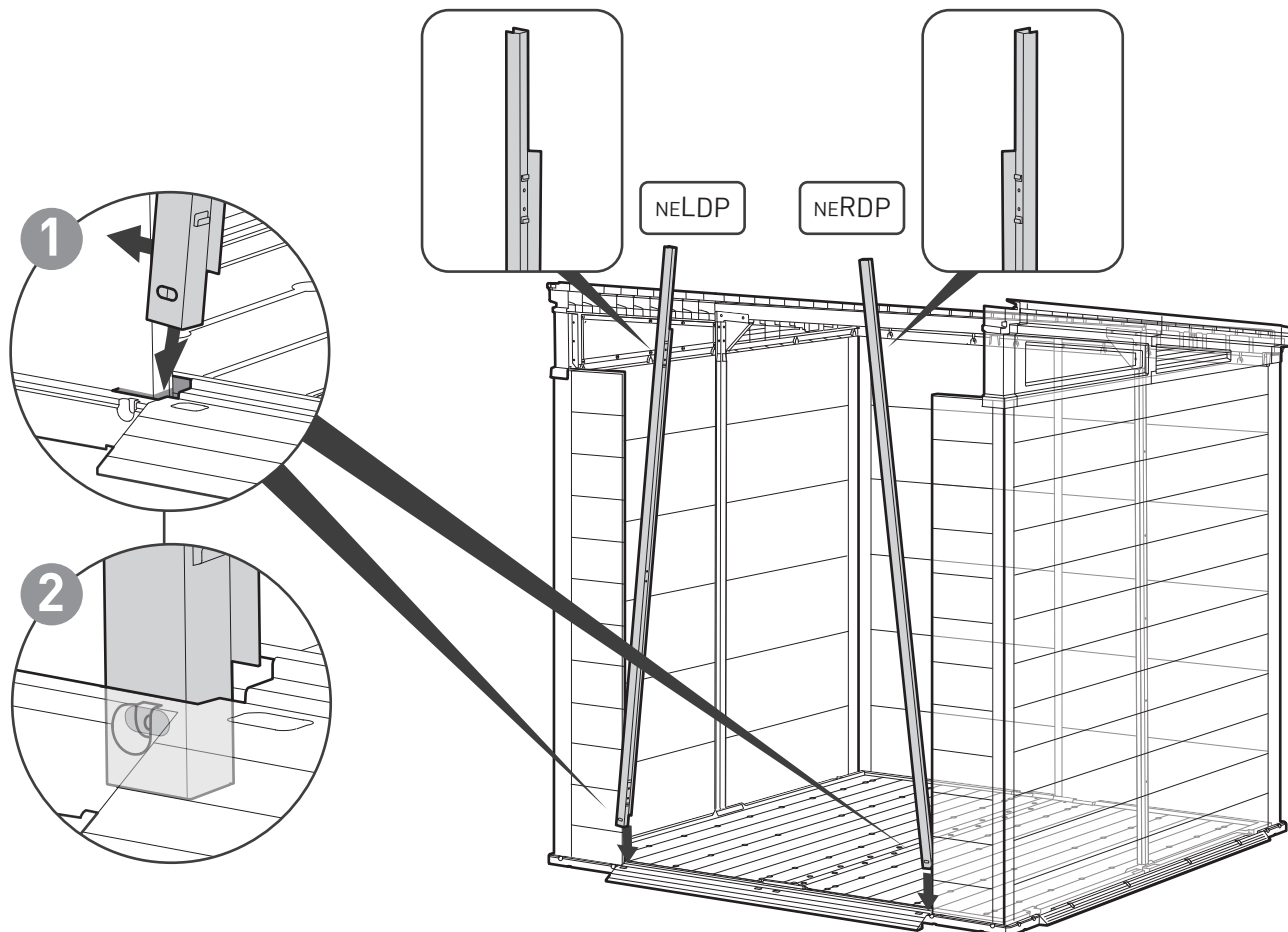

31

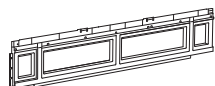

NEFF (x1)

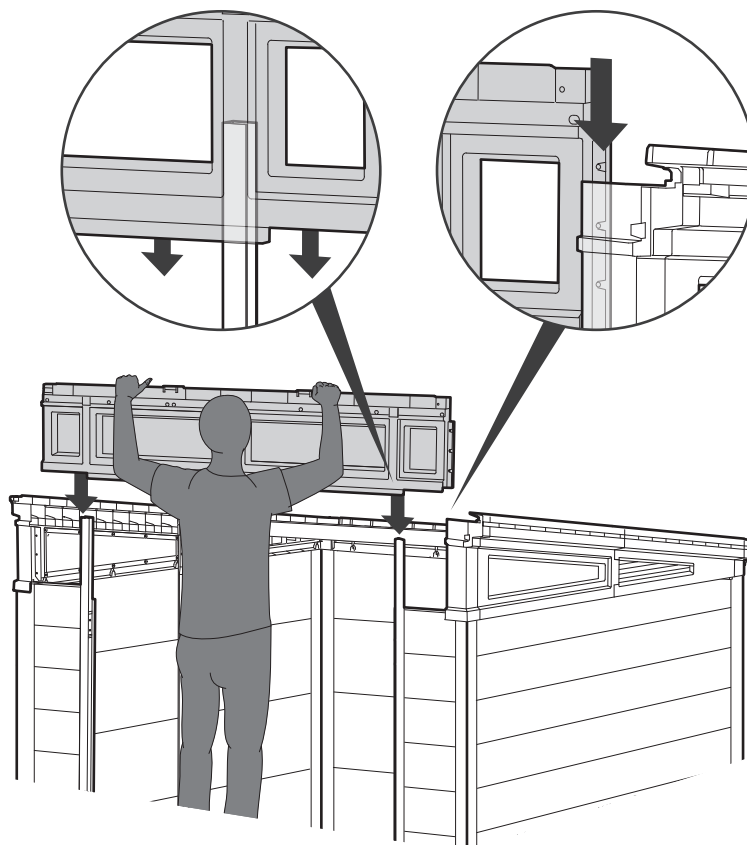

32

sc15 (x8)

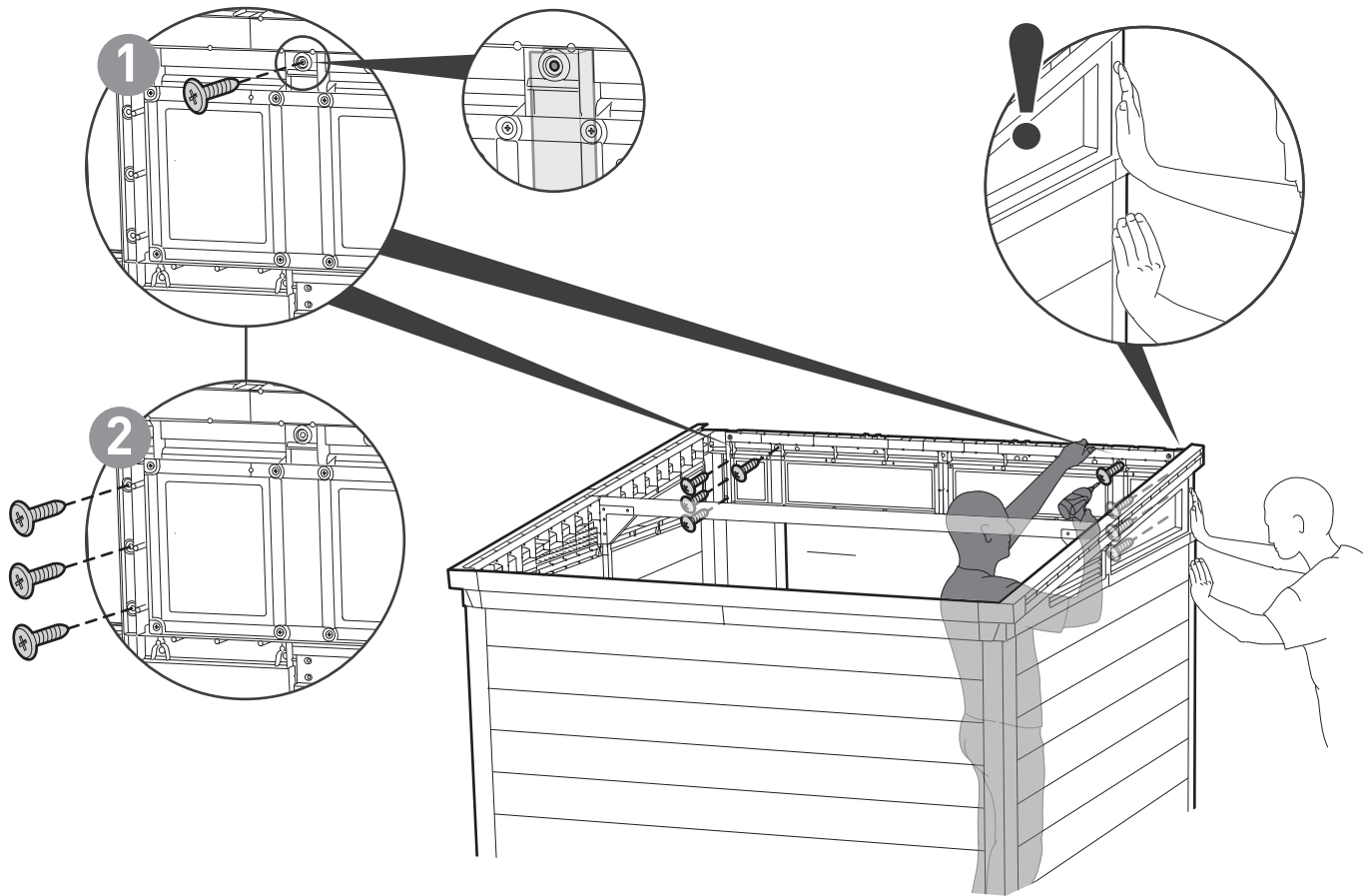

33

NERA (x2)

