

KETER

Create amazing spaces™

DUOTECH

TM

OAKLAND™ 7513

USER MANUAL | MODE D'EMPLOI | MANUAL DEL USUARIO | MONTAGEANLEITUNG |
MONTAGEHANDLEIDING | MANUALE PER L'UTENTE | MANUAL DO UTILIZADOR

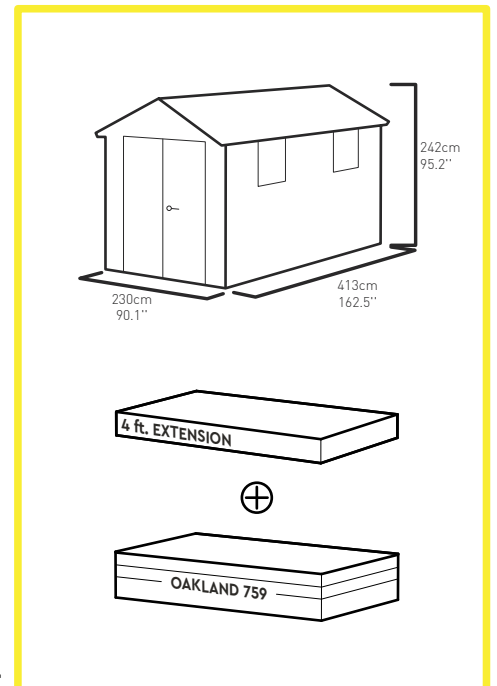
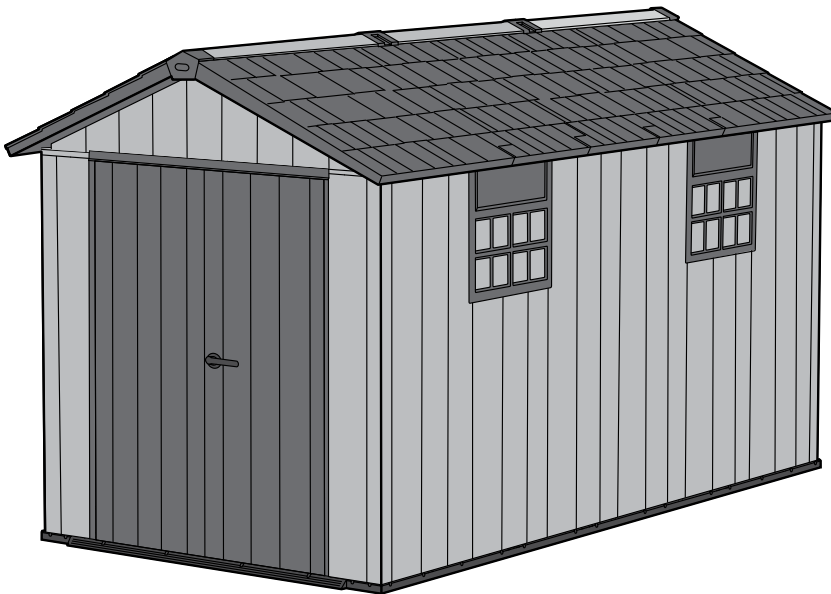
**IMPORTANT | IMPORTANT | IMPORTANTE | BALANGRIJK | IMPORTANTE**

RETAIN FOR FUTURE REFERENCE: READ CAREFULLY

À CONSERVER POUR DE FUTURS BESOINS DE RÉFÉRENCE : À LIRE SOIGNEUSEMENT

CONSERVE PARA FUTURA REFERENCIA. LEA CUIDADOSAMENTE

BEWAREN VOOR TOEKOMSTIGE RAADPLEGING: ZORGVULDIG LEZEN

CONSERVARE PER RIFERIMENTO FUTURO: LEGGERE ATTENTAMENTE

For outdoor use only. Not for commercial use | Utilisation non commerciale à l'extérieur seulement | Para uso externo. No para uso comercial. | Alleen voor buitenshuis gebruik. Niet voor commercieel gebruik | Uso esterno. Non indicato per usi commerciali

SKU: 17210605

US, Canada
Tel: +1877-638-7056, NACS@keter.com
Mon - Fri | 8am - 6pm ET / Du lundi au vendredi : 8h -18h
Sat - Sun | 9am - 6pm ET / Samedi et dimanche : 9h-18h
UK
Tel: +44-121-506-0008, CSUK@keter.com
Mon - Fri | 8:30am - 5pm

For other European countries see the last page
Pour les autres pays d'Europe, voir la dernière page
Para otros países europeos vea la última página
Voor andere Europese landen, zie de laatste pagina
Per altri Paesi europei, consultare l'ultima pagina

WARRANTY ACTIVATION

Thank you for your purchase of the Keter shed.
In order to activate your warranty, please log onto
our website and fill in the form under warranty
activation.

ACTIVATION DE LA GARANTIE

Nous vous remercions pour l'achat de votre abri
Keter. Pour activer votre garantie, veuillez vous
connecter à notre site Web et remplir le formulaire
d'activation de la garantie.

ACTIVACION DE GARANTIA

Gracias por su compra de una caseta Ket er. Para
activar su garantía, ingrese en nuestro sitio de
internet y complete el formulario que esta bajo la
activación de garantía.

Level the ground surface | Nivelez la surface du sol | Nivela la superficie del suelo | Ebenen Sie die Bodenoberfläche | Maak de ondergrond vlak | Livellare la superficie del terreno | Nivela a superfície do solo | 땅고르기

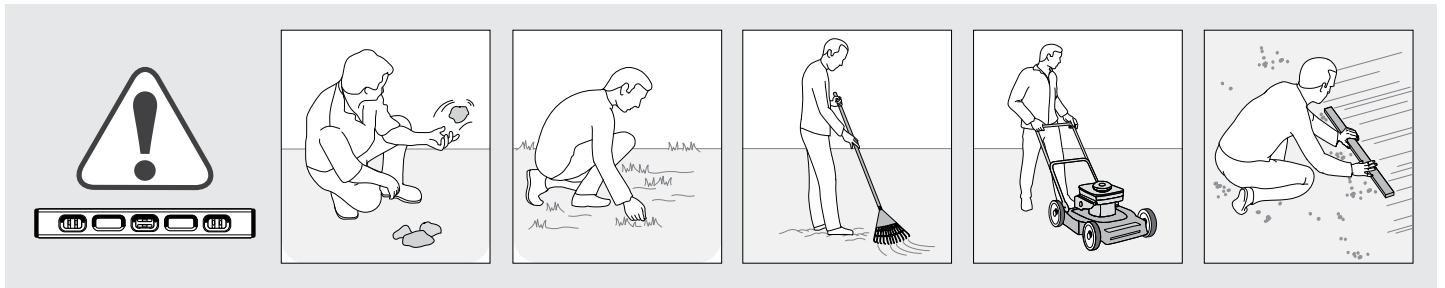

Recommendation: Construct a wooden or concrete base as a foundation | Recommandation: fabriquez une base en bois ou en béton en guise de fondation | Recomendación: construya una base de madera o de cemento a modo de cimiento | Empfehlung: Bauen Sie als Fundament eine Grundfläche aus Holz oder Beton | Aanbeveling: maak een houten of betonnen ondergrond als fundering | Raccomandazione: Costruire una base di legno o di cemento come fondamenta | Recomendação: Construa uma base de madeira ou de cimento como fundação

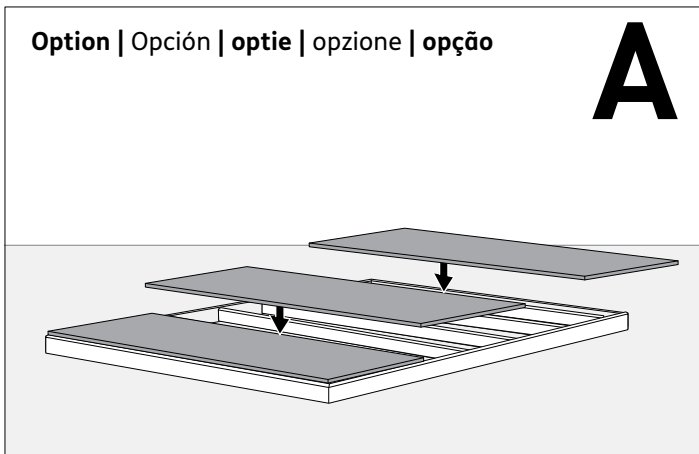

For external access during assembly, make sure to leave enough room around the outside of the shed assembly site.

Pour un accès externe au cours du montage, veillez à laisser suffisamment de place autour du site de montage.

Para tener un acceso exterior durante el montaje, asegúrese de dejar suficiente espacio alrededor del lugar de montaje del cobertizo.

Lassen Sie am Aufstellungsort außerhalb des Schuppens ausreichend Platz, so dass Sie während des Aufbaus von außen Zugang zum Schuppen haben.

Om tijdens de montage aan de buitenkant van het schuurtje te kunnen werken, moet u ervoor zorgen dat u genoeg ruimte laat aan de buitenkant van de montageplaats.

Per accedere alle parti esterne della casetta durante l'assemblaggio, assicurarsi di lasciare abbastanza spazio attorno al luogo di assemblaggio.

Para ter acesso externo durante a montagem certifique-se de que deixa espaço suficiente em redor do exterior do local de montagem do abrigo.

External floor measurements are: | Mesures externes du plancher: | Las medidas del suelo externo son: | Die Außen-Bodenmaße betragen: | De afmetingen van de externe vloer zijn: | Le mesure del pavimento esterno sono: | As medidas externas do chão são:

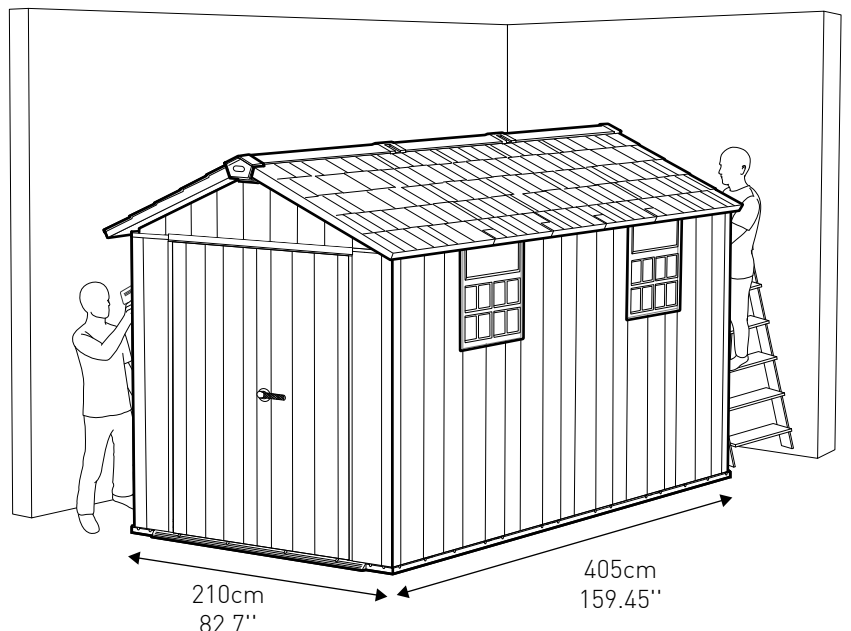

BEFORE STARTING ASSEMBLY | AVANT DE COMMENCER LE MONTAGE | ANTES DE EMPEZAR EL ARMADO | VOR MONTAGEBEGINN | VOORDAT U BEGINT TE MONTEREN | PRIMA DI INIZIARE L'ASSEMBLAGGIO | ANTES DE INICIAR A MONTAGEM

Read the care and safety guidelines at the end of this manual | Check to ensure that there are no missing or damaged parts BEFORE starting or arranging assembly | Remove all parts from the package(s) and spread them out on a clean work surface | Review all assembly instructions | Assemble all the parts according to the directions in this manual. Do not skip any steps.

Lisez les instructions de précaution et de sécurité à la fin de ce manuel | Assurez-vous qu'il n'y a pas de pièces manquantes ou endommagées AVANT de commencer ou d'organiser l'assemblage | Retirez toutes les pièces du/des paquet(s) et étalez-les sur une surface de travail propre | Lisez toutes les instructions de montage | Assemblez toutes les pièces selon les instructions de ce manuel. Ne sautez aucune étape.

Lea las intrucciones de precauciones y seguridad que están al final de este manual | Asegúrese de que no faltan piezas ni están dañadas ANTES de comenzar o disponer el montaje | Saque todas las piezas del paquete o paquetes y póngalas sobre una superficie de trabajo limpia | Revise todas las instrucciones de montaje | Monte todas las piezas según las instrucciones de este manual. No se saltee ningún paso.

Lesen Sie die Sicherheitsrichtlinien am Ende des Benutzerhandbuchs durch | Prüfen Sie bitte VOR dem Zusammenbau, dass keine Teile beschädigt sind oder fehlen | Nehmen Sie alle Teile aus der Verpackung und breiten Sie sie auf einer sauberen Arbeitsfläche aus | Gehen Sie noch einmal die komplette Aufbauanleitung durch | Bauen Sie alle Teile entsprechend der Anleitung in diesem Handbuch zusammen. Lassen Sie dabei keinen Arbeitsschritt aus.

Lees de richtlijnen over zorg en veiligheid achterin deze handleiding | Controleer of er geen onderdelen ontbreken of beschadigd zijn, VOORDAT u met de montage begint | Haal alle onderdelen uit het pakket (of uit de pakketten) en leg ze op een schoon werkoppervlak | Bekijk alle montagehandleidingen | Monteer alle onderdelen volgens de aanwijzingen van deze handleiding. Sla geen stappen over.

Leggere le linee guida di assistenza e sicurezza alla fine di questo manuale | Assicurarsi che non ci siano parti mancanti o danneggiate PRIMA di iniziare l'assemblaggio | Estrarre tutti i componenti dall'imballo e posizionarli su una superficie di lavoro pulita | Consultare tutte le istruzioni di montaggio | Assemblare tutti i componenti secondo le istruzioni contenute nel manuale. Non saltare nessuna fase.

Leia as diretrizes de cuidados e segurança que constam da parte final deste manual | Verifique para se assegurar de que não há peças em falta ou danificadas ANTES de começar a preparar a montagem | Retire todas as peças da embalagem e espalhe-as numa superfície de trabalho limpa | Reveja todas as instruções de montagem | Monte todas as peças de acordo com as instruções do manual. Não salte quaisquer passos.

REQUIRED TOOLS | OUTILS EXIGÉS | HERRAMIENTAS NECESARIAS | BENÖTIGTE WERKZEUGE | BENODIGD GEREEDSCHAP | ATTREZZATURA OCCORRENTE | FERRAMENTAS NECESSÁRIAS

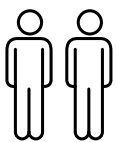
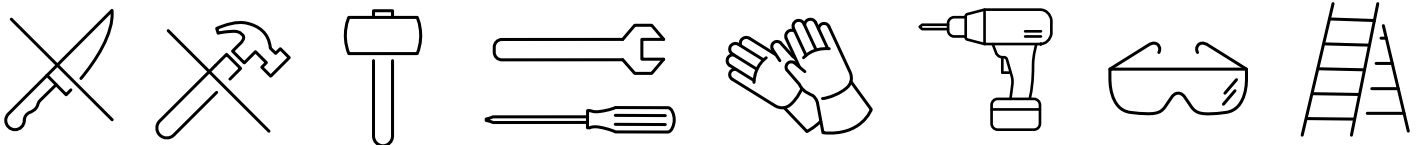

ASSEMBLY REQUIRES TWO PEOPLE | LE MONTAGE DOIT ÊTRE EFFECTUÉ PAR DEUX PERSONNES | SE NECESITAN DOS PERSONAS PARA EL MONTAJE | ZWEI PERSONEN ZUR MONTAGE NOTWENDIG | MONTAGE VEREIST TWEE PERSONEN | L'ASSEMBLAGGIO RICHIEDE DUE PERSONE | A MONTAGEM EXIGE DUAS PESSOAS

SHED PARTS | PIÈCES DE L'ABRI | PARTES DEL COBERTIZO | TEILE DES SCHUPPENS | ONDERDELEN VAN HET SCHUURTJE | COMPONENTI DELLA CASETTA | PEÇAS DO ABRIGO

Remove all parts from the package(s) and spread them out on a clean work surface. Code letters are imprinted on each part for easy identification | Retirez toutes les pièces du/des paquet(s) et étalez-les sur une surface de travail propre. Des lettres sont imprimées sur chaque pièce pour une identification facile | Saque todas las piezas del paquete o paquetes y póngalas sobre una superficie de trabajo limpia. El código de letras está marcado en cada pieza para que sea más fácil identificarla | Nehmen Sie alle Teile aus der Verpackung und breiten Sie sie auf einer sauberen Arbeitsfläche aus. Auf jedem Teil sind Kennbuchstaben aufgedruckt, die die Zuordnung der einzelnen Teile erleichtern | Haal alle onderdelen uit het pakket (of uit de pakketten) en leg ze op een schoon werkoppervlak. Op ieder onderdeel zijn codes aangebracht om ze eenvoudig te kunnen herkennen | Rimuovere tutti i componenti dall'imballo e posizzarli su una superficie di lavoro pulita. I codici identificativi sono impressi in ogni componente per una semplice identificazione | Retire todas as peças da embalagem e espalhe-as numa superfície de trabalho limpa. Existem letras de código impressas em cada peça para fácil identificação

FLOOR PARTS | ÉLÉMENTS DU PLANCHER | PARTES DEL SUELO | BODENTEILE | VLOERPANELEN | COMPONENTI DEL PAVIMENTO | PEÇAS DO CHÃO

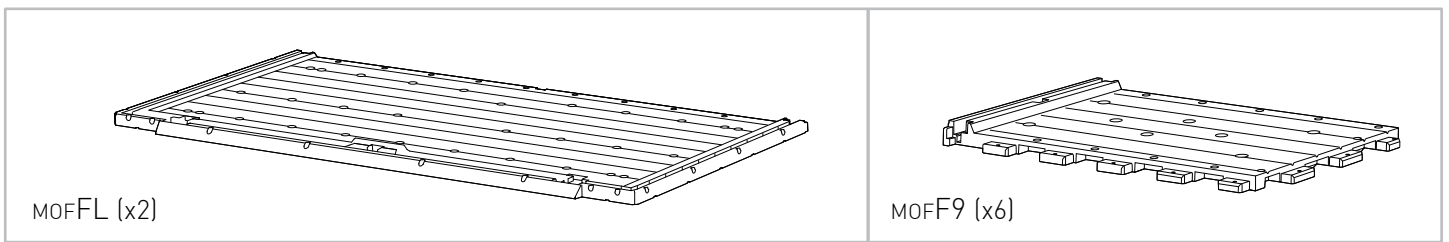

WALL PARTS | PIÈCES DES MURS | PARTES DE LAS PAREDES | WANDELEMENTE | WAND ONDERDELEN | COMPONENTI DELLE PARETI | PAINÉIS LATERAIS

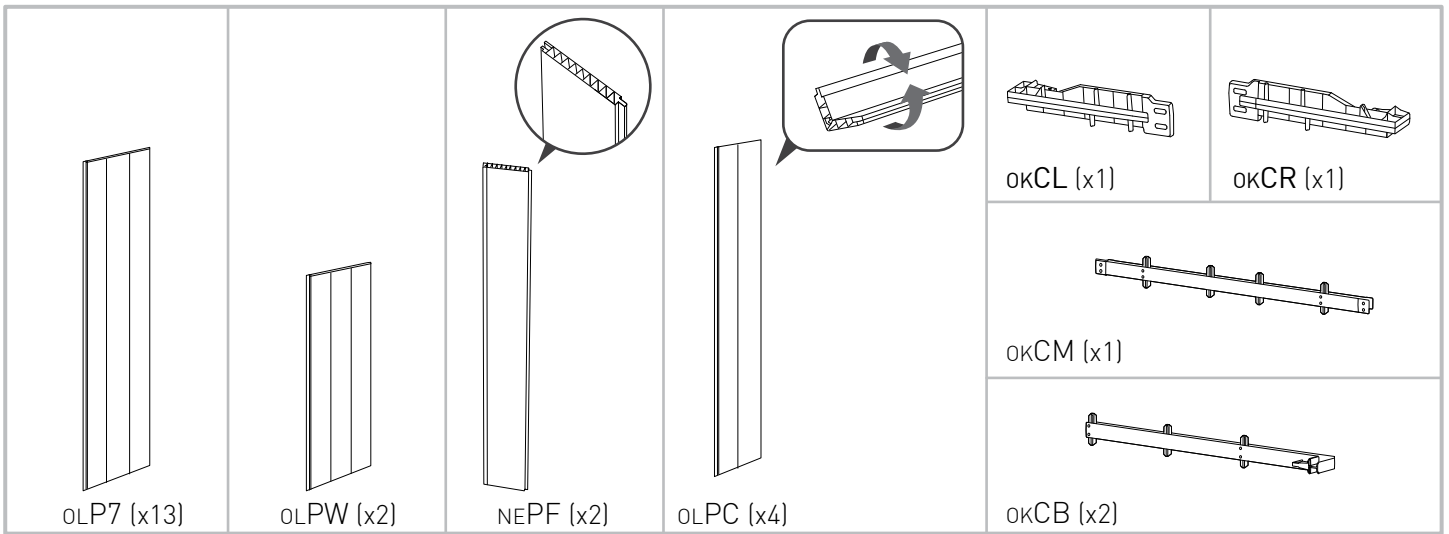

DOOR PARTS | PIÈCES DE LA PORTE | PARTES DE LA PUERTA | TÜRELEMENTE | DEURONDERDELEN | COMPONENTI DELLA PORTA | PEÇAS DAS PORTAS

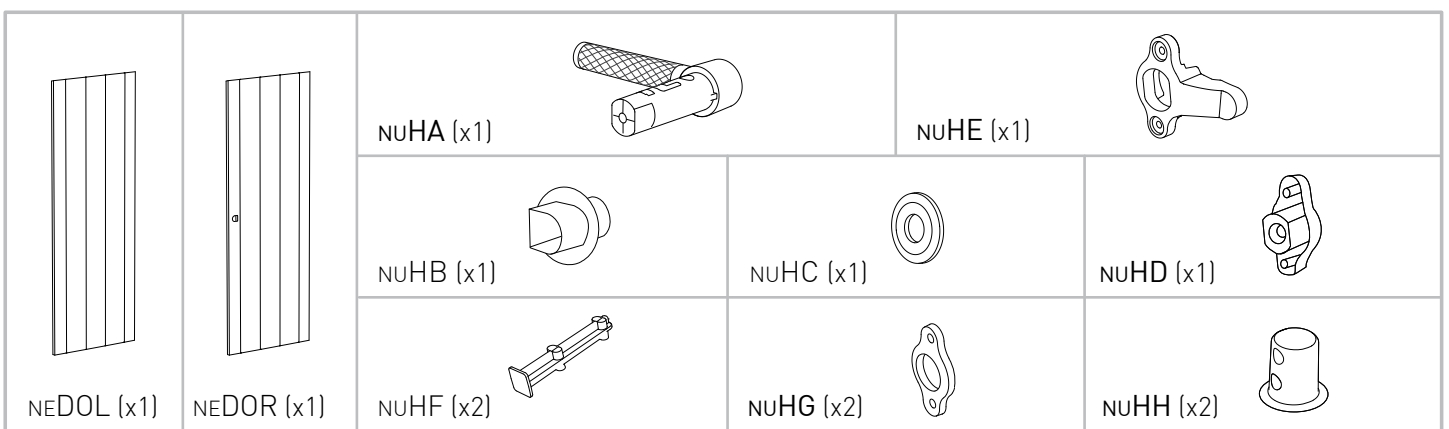

ROOF PARTS | PIÈCES DU TOIT | PARTES DEL TECHO | DACHELEMENTE | DAKONDERDELEN | COMPONENTI DEL TETTO | PEÇAS DO TELHADO

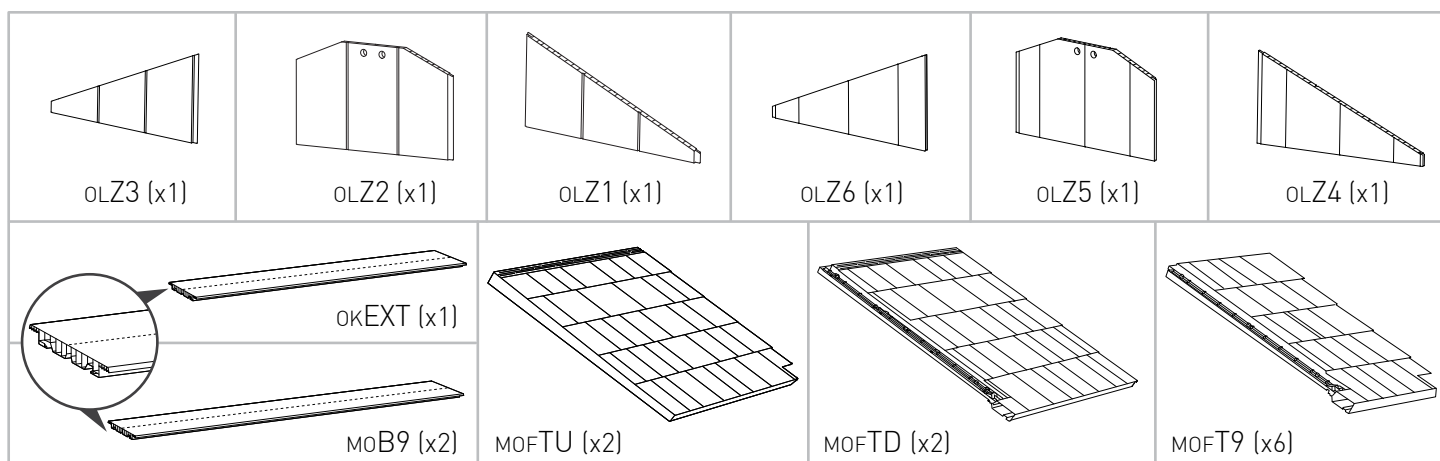

METAL PARTS | PIÈCES MÉTALLIQUES | PIEZAS METÁLICAS | METALLTEILE | METALEN DELEN | COMPONENTI IN METALLO | PARTES METÁLICAS

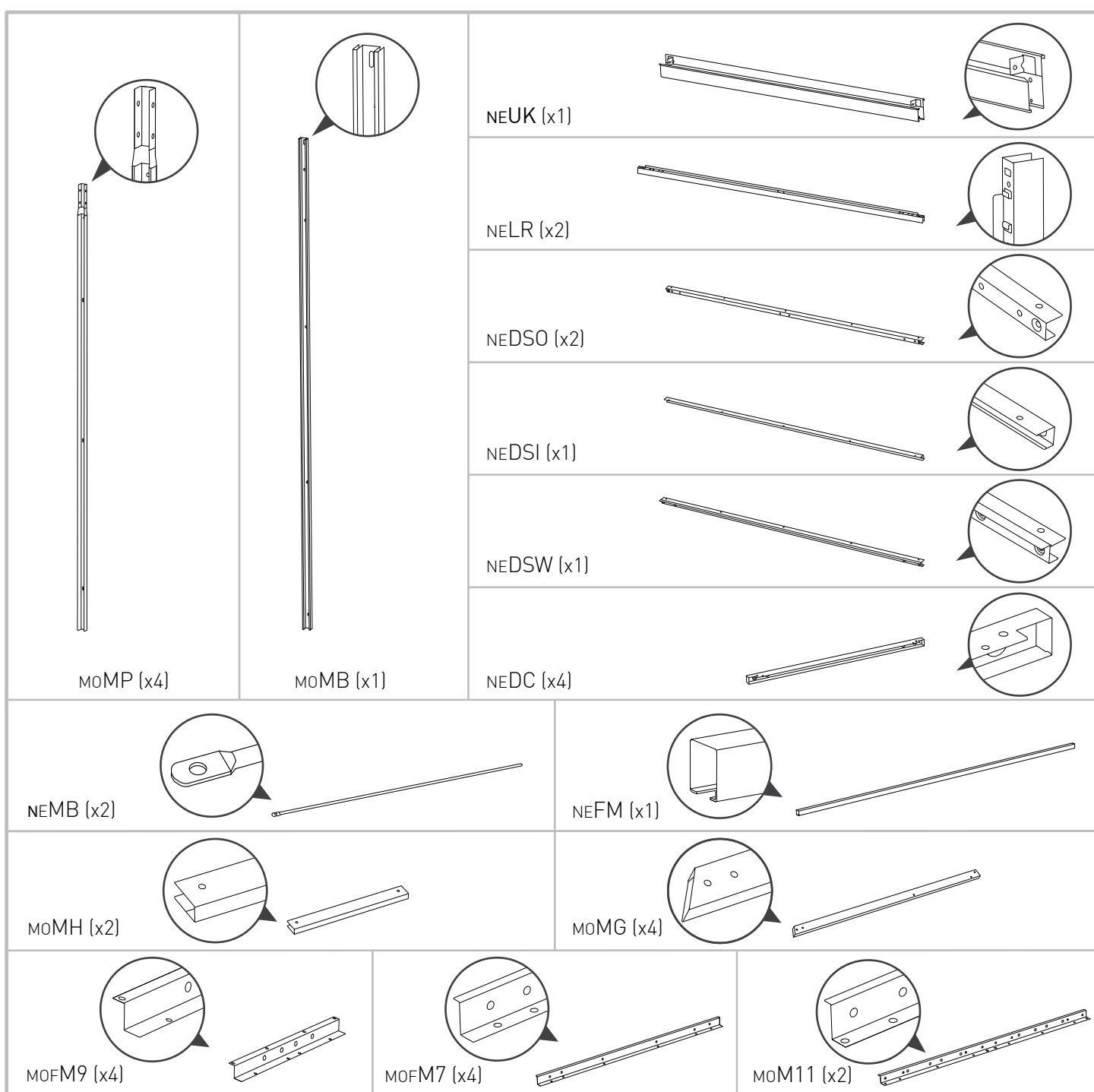

WINDOW PARTS | PIÈCES DE LA FENÊTRE | PARTES DE LA VENTANA | FENSTERELEMENTE | RAAMONDERDELEN | COMPONENTI DELLE FINESTRE | PEÇAS DA JANELA

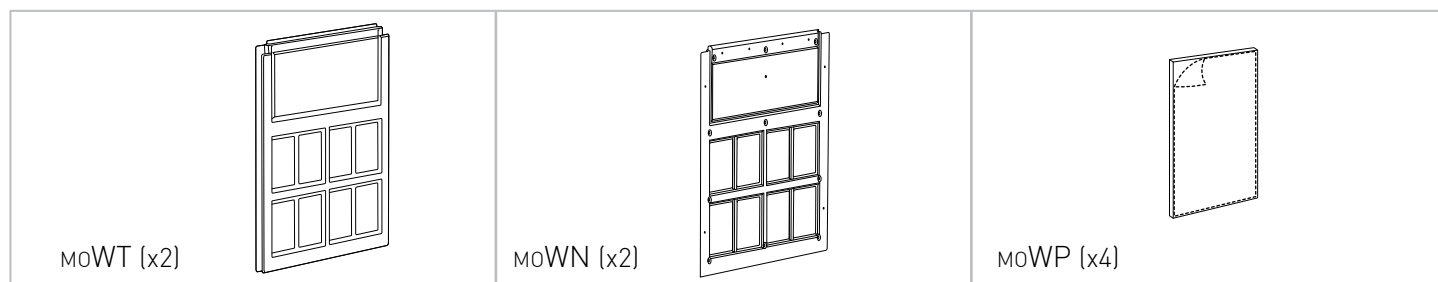

SMALL PARTS | PETITES PIÈCES | PARTES PEQUEÑAS | KLEINTEILE | KLEINE ONDERDELEN | MINUTERIA | PEÇAS PEQUENAS

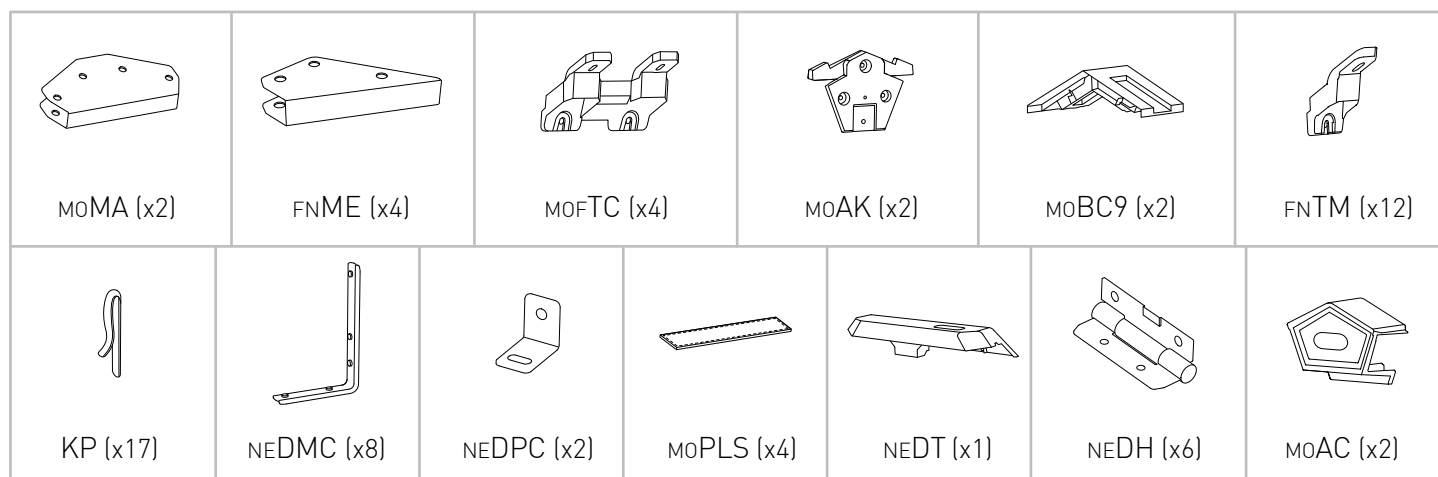

SCREWS | VIS | TORNILLOS | SCHRAUBEN | SCHROEVEN | VITI | PARAFUSOS

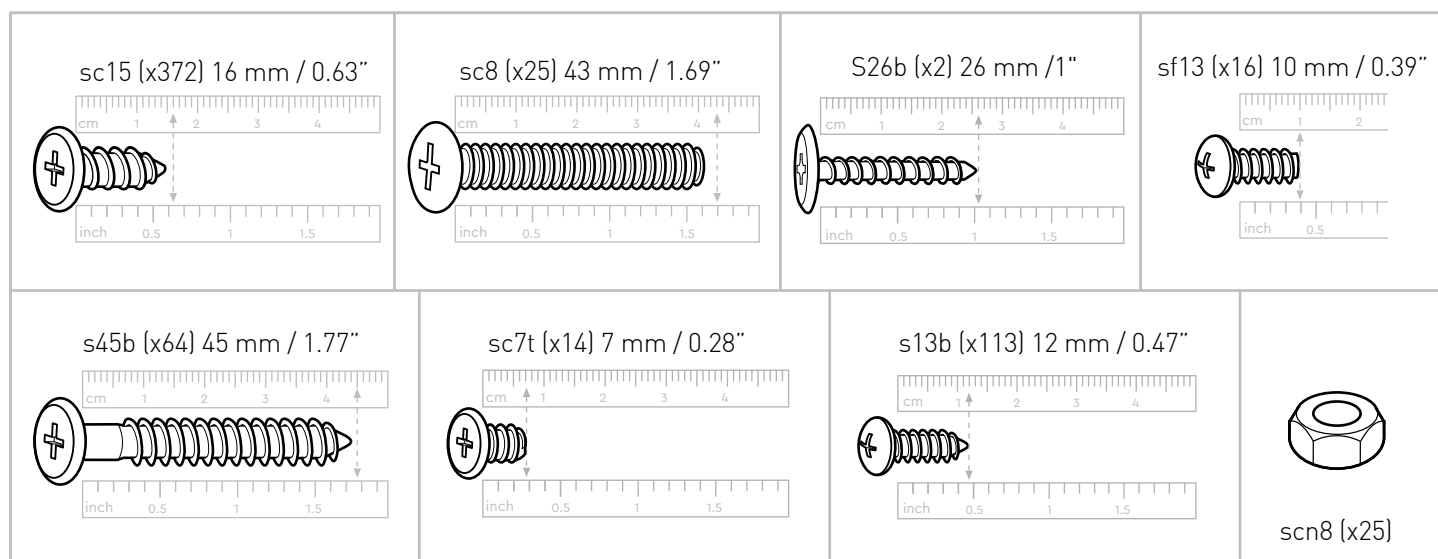

Packaging may contain some additional small parts for use as spare parts | L'emballage peut contenir de petites pièces supplémentaires à utiliser comme pièces de rechange | El envoltorio puede contener algunas piezas pequeñas adicionales que se pueden utilizar como repuestos | In der Verpackung können kleine Zusatzteile enthalten sein, die als Ersatzteile genutzt werden können | De verpakking kan een aantal kleine extra onderdelen bevatten, die als reserveonderdeel gebruikt kunnen worden | L'imballo potrebbe contenere piccoli componenti supplementari da utilizzare come ricambistica | A embalagem pode conter algumas pequenas peças adicionais para utilização como peças de reposição

NOTE: Due to variations in production, the actual assembled size may vary slightly from the specified dimensions.

REMARQUE: En raison de variantes dans la production, la taille de montage réelle peut différer quelque peu des dimensions indiquées.

NOTA: debido a las variaciones en la producción, el tamaño real al montarlo puede variar ligeramente con respecto a las dimensiones especificadas.

BITTE BEACHTEN: Aufgrund von Abweichungen in der Herstellung kann die tatsächliche Größe leicht von den angegebenen Maßen abweichen.

LET OP: vanwege afwijkingen in de productie kan de werkelijke afmeting na montage een klein beetje afwijken van de opgegeven afmetingen

NOTA: A causa di variazioni nella produzione, le dimensioni effettive del prodotto assemblato potrebbero variare leggermente da quelle indicate.

NOTA: Devido a variações na produção o tamanho real da montagem poderá variar ligeiramente das dimensões especificadas.

1

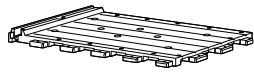

MOFF9 (x6)

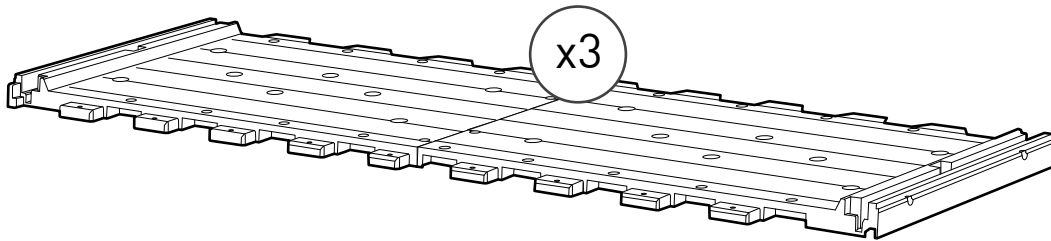
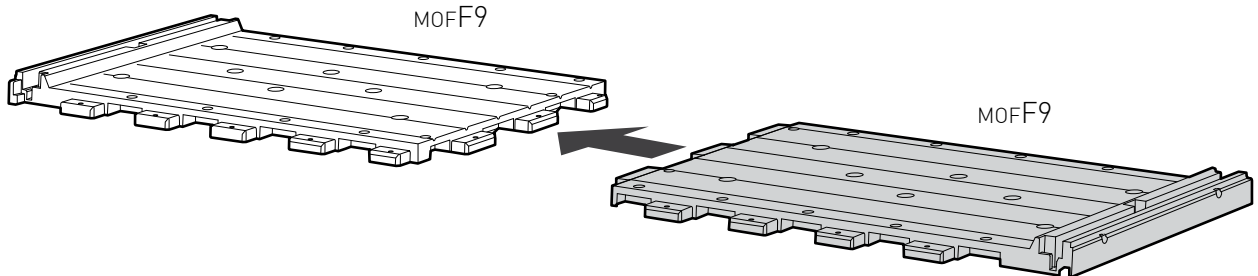
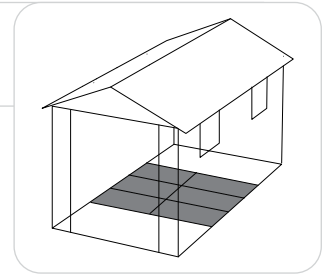

2

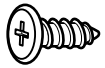

sc15 (x12)

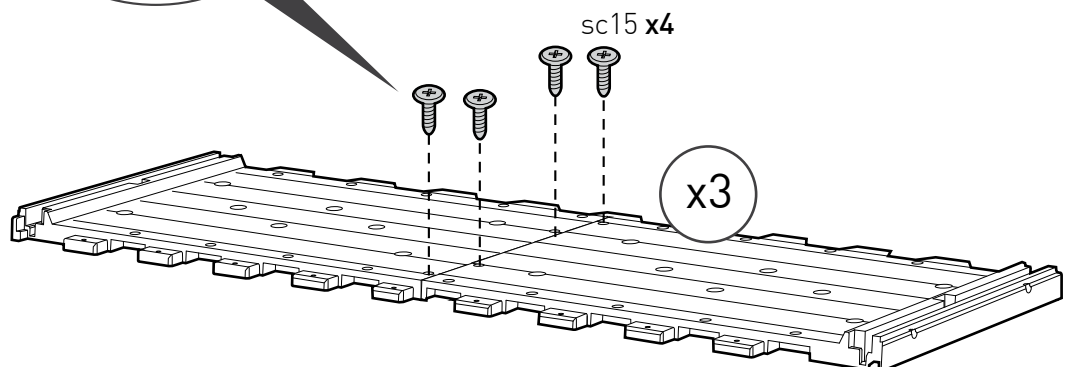
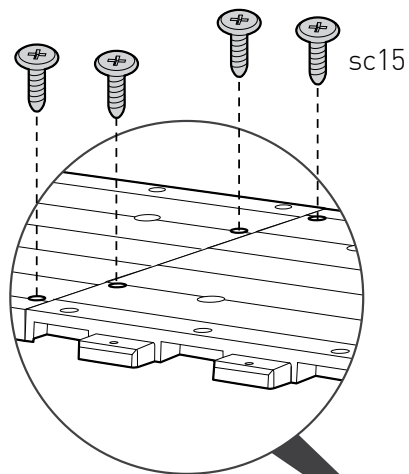
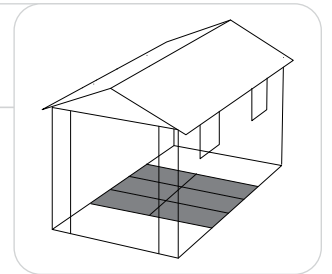

3

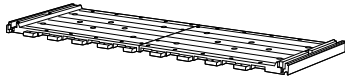

MOFF9 + MOFF9 (x3)

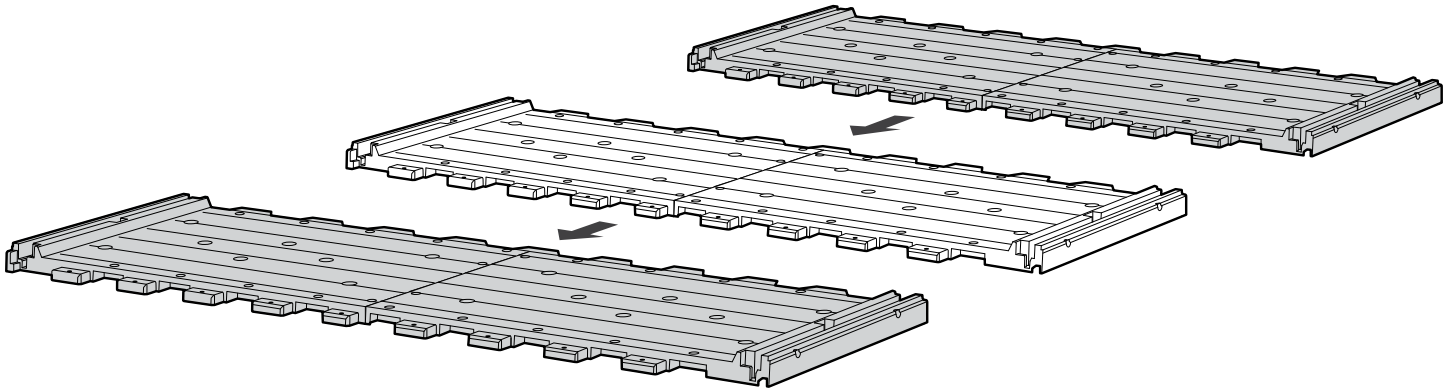
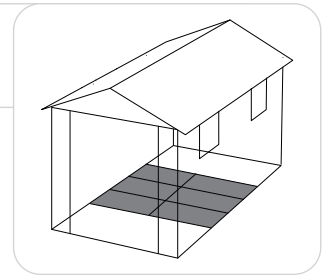

4

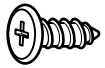

sc15 (x36)

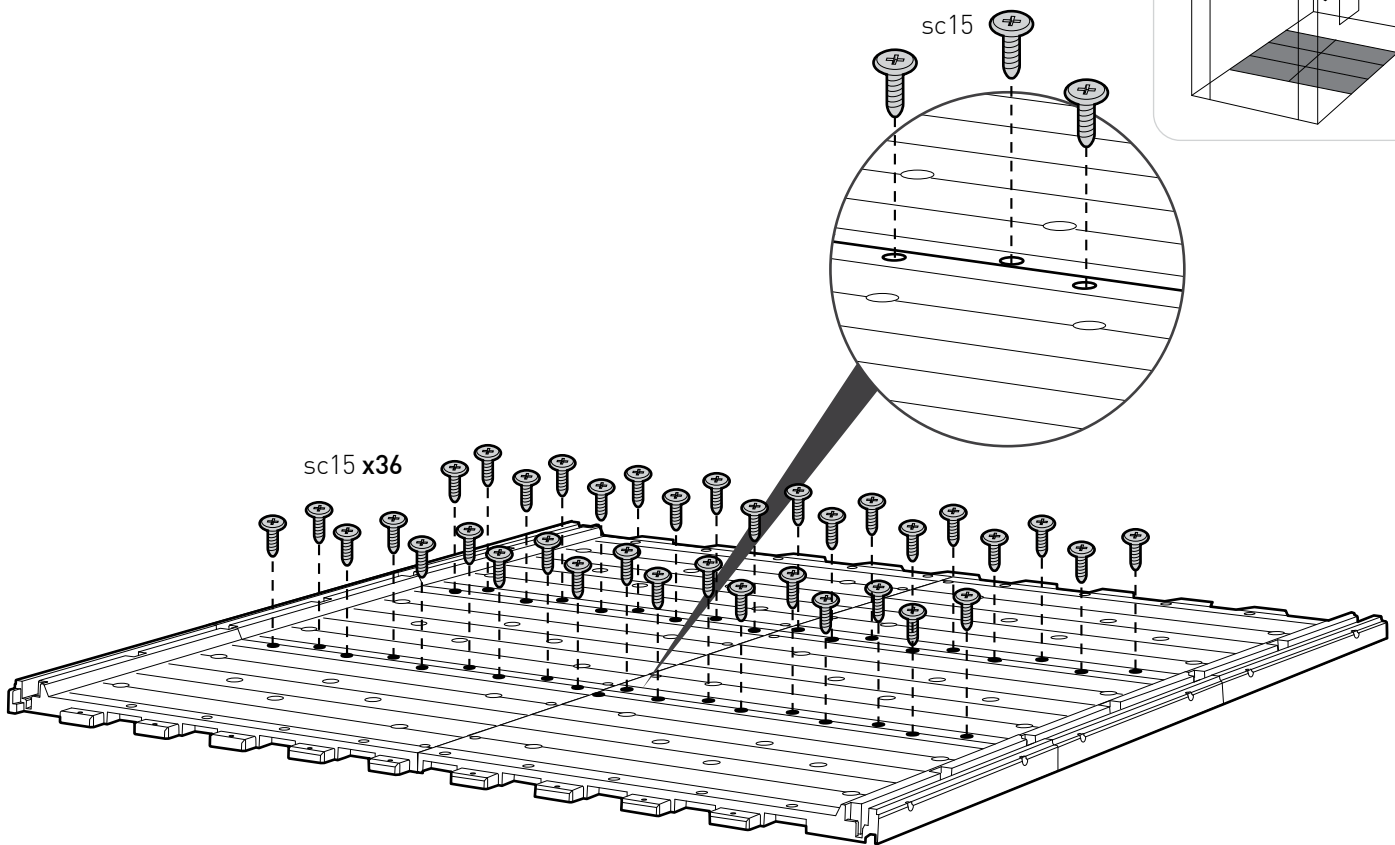
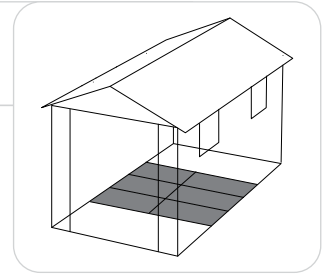

5

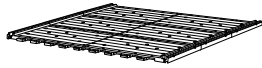

MOFF9 + MOFF9 (x3)



MOFFL (x2)

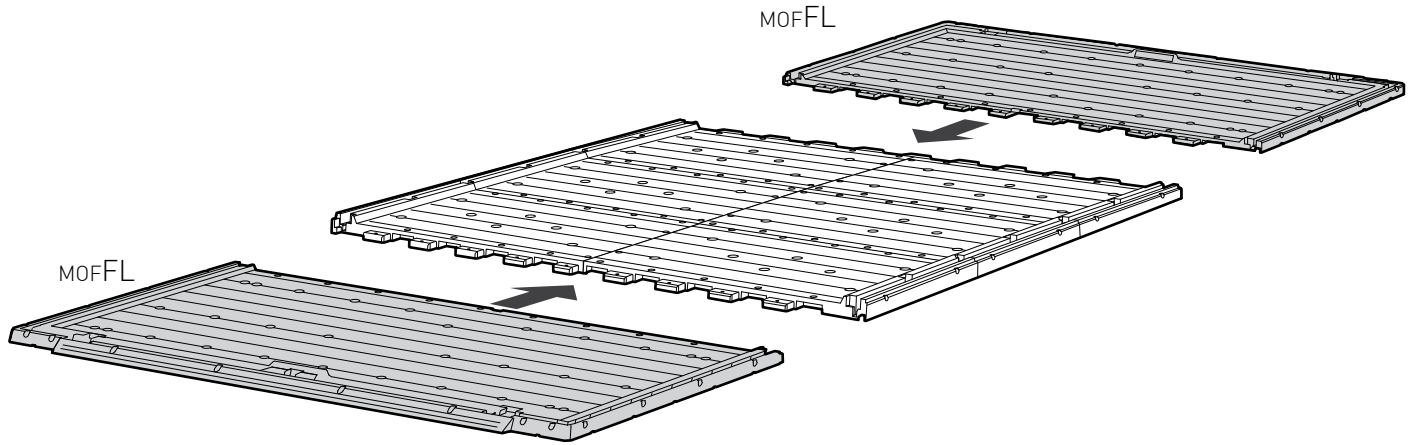
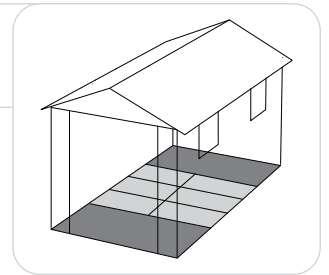

6

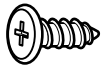

sc15 (x36)

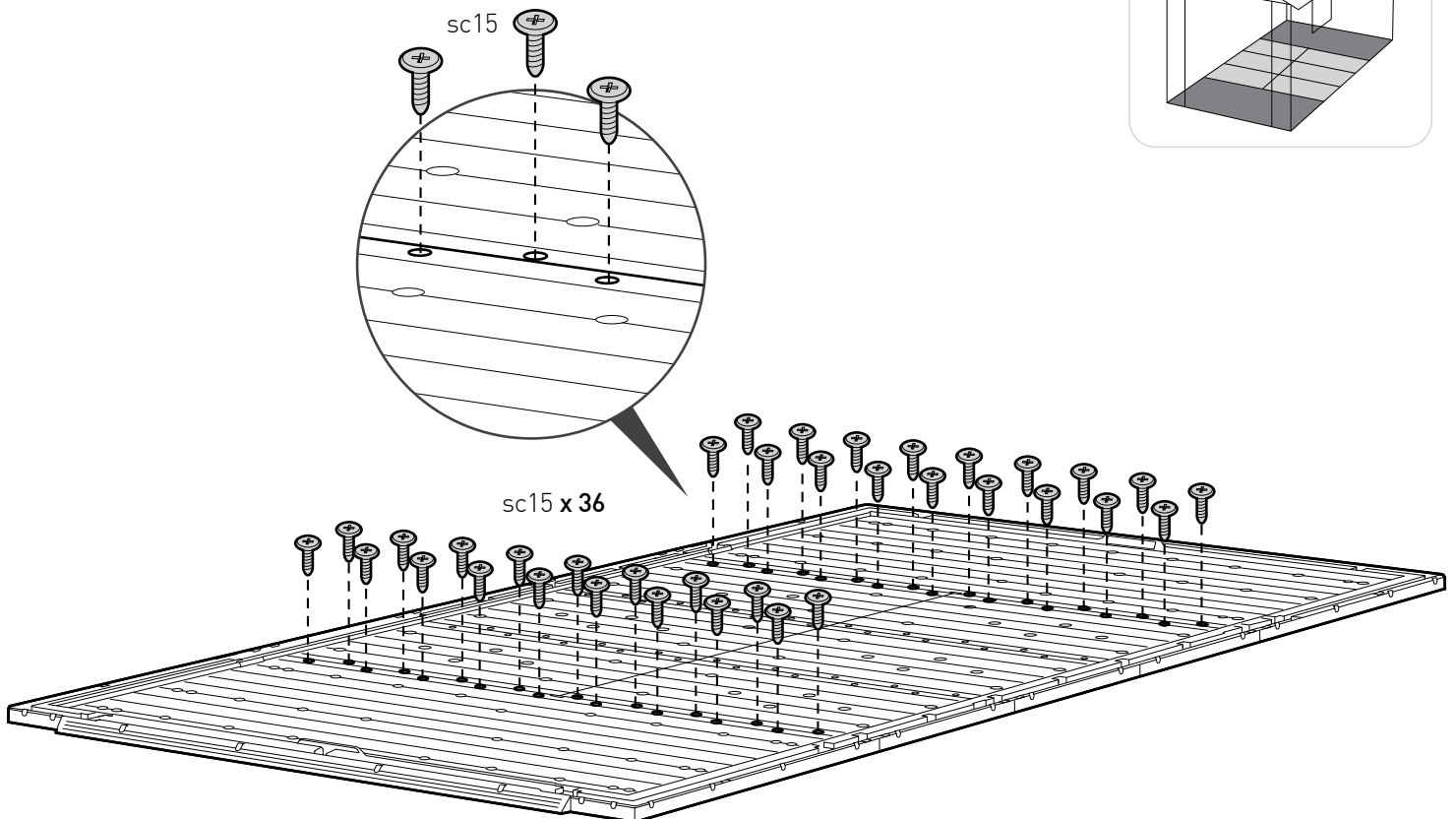
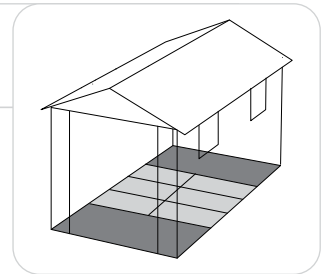

7



NEDT (x1)



s26b (x2)

No pre-drilled holes | Pas de trous pré-perçés | Sin agujeros pretaladrados |
Ohne vorgebohrte Löcher | **Geen voorgeboorde gaten** | Predisposizione per fori
non presente | **Sem buracos perfurados previamente**

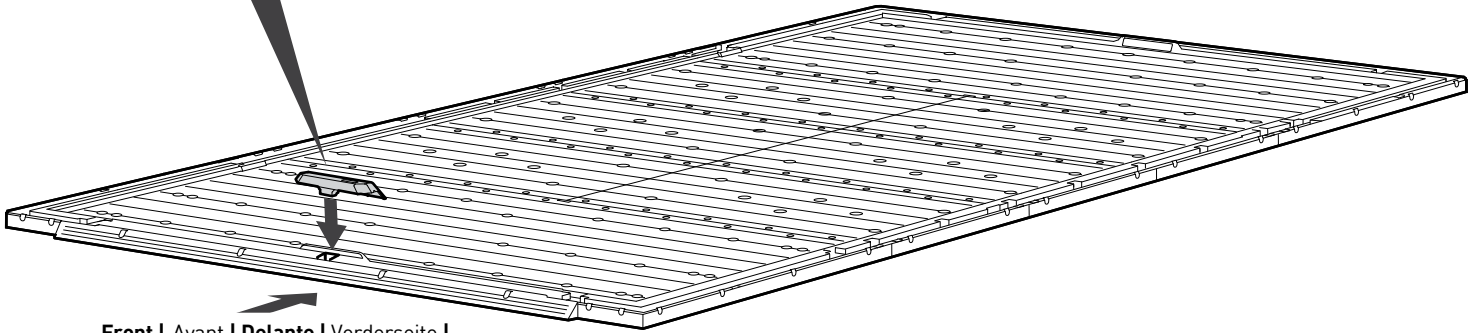
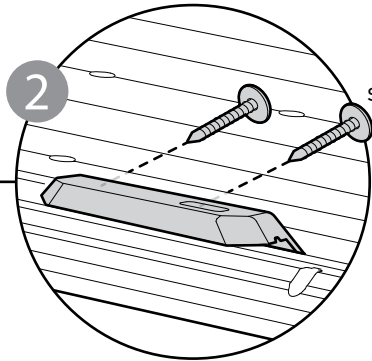
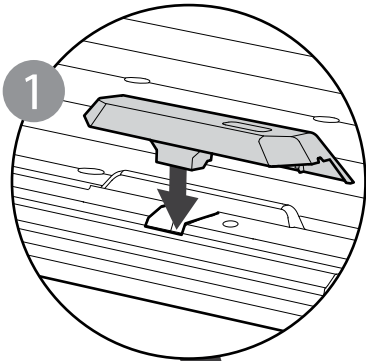

Front | Avant | Delante | Vorderseite |
Voorkant | Anteriore | Frente

WALL ASSEMBLY | MONTAGE DU MUR | ARMADO DE PAREDES | MONTAGE DER WÄNDE | MONTAGE VAN DE MUREN | ASSEMBLAGGIO DELLE PARETI | MONTAGEM DA PAREDE

8 |  oLPC (x1) |  oLP7 (x1) | 

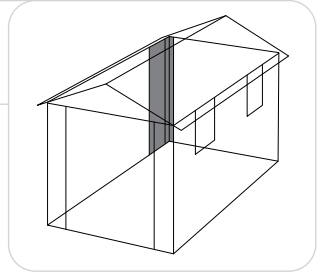
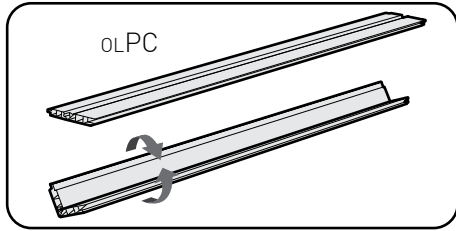
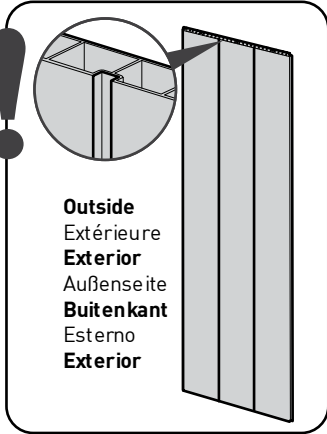

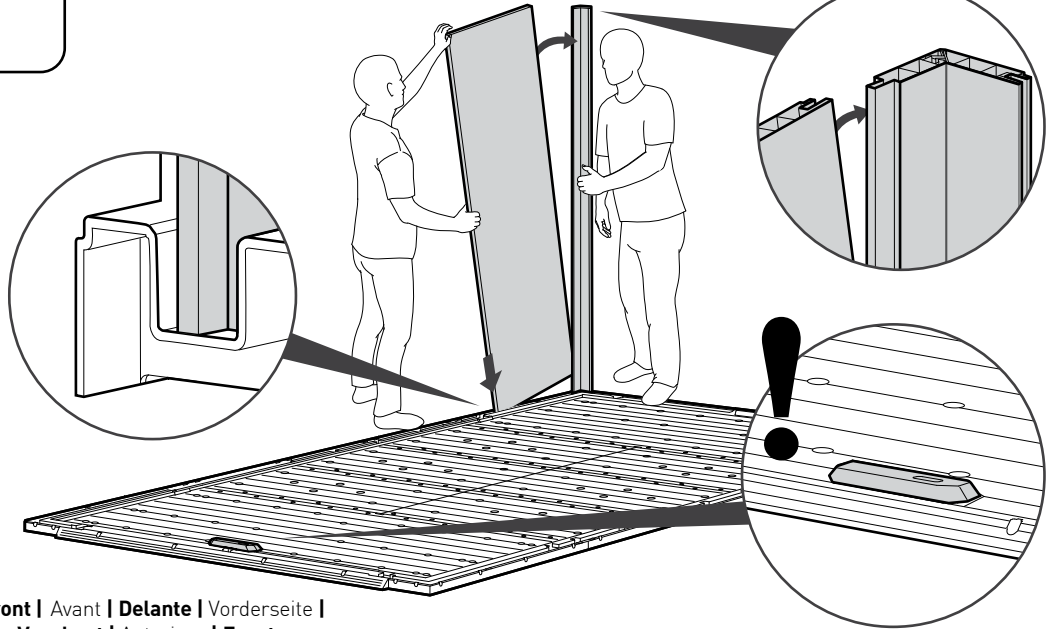

Outside
 Extérieure
Exterior
 Außenseite
Buitenkant
 Esterno
Exterior

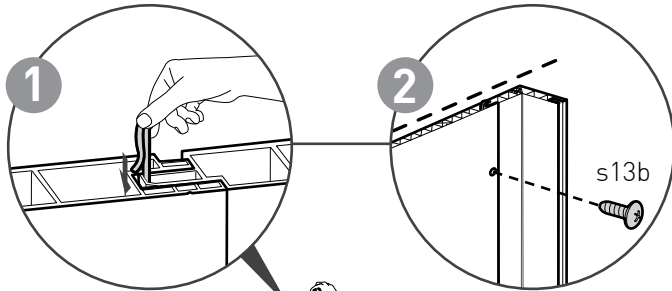

**Front | Avant | Delante | Vorderseite |
 Voorkant | Anteriore | Frente**

9 |  KP (x1) |  s13b (x1) | 

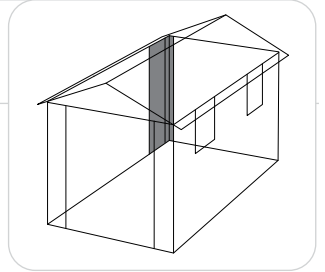
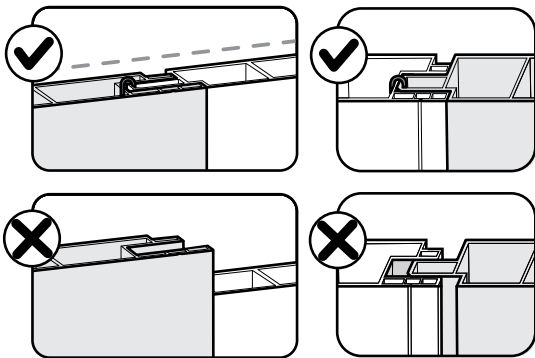
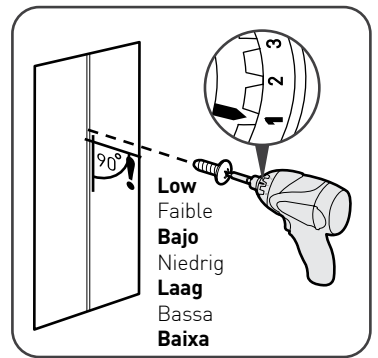

1 **2** s13b

Low
 Faible
Bajo
 Niedrig
Laag
 Bassa
Baixa

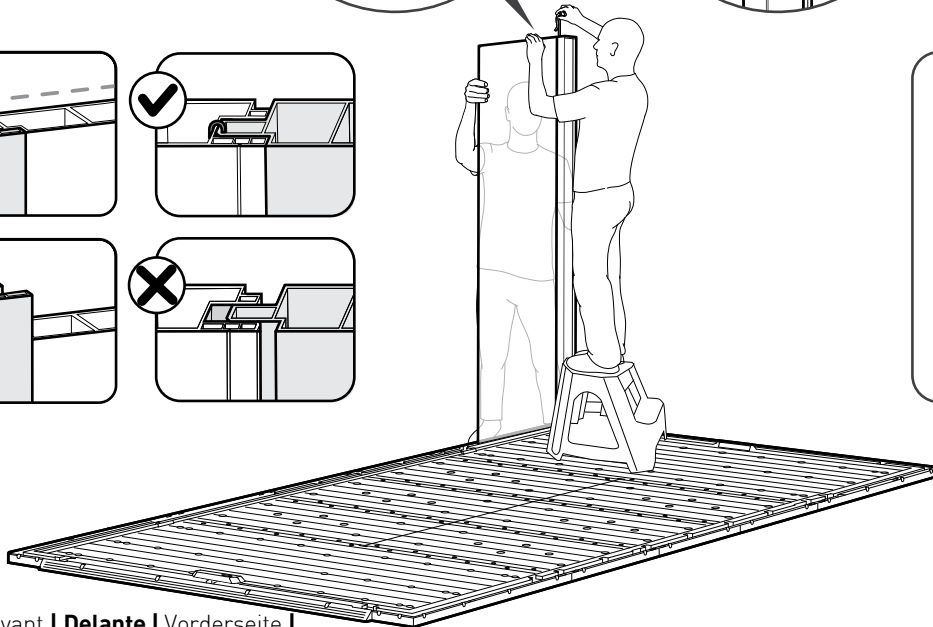

**Front | Avant | Delante | Vorderseite |
 Voorkant | Anteriore | Frente**

10



oLP7 (x1)

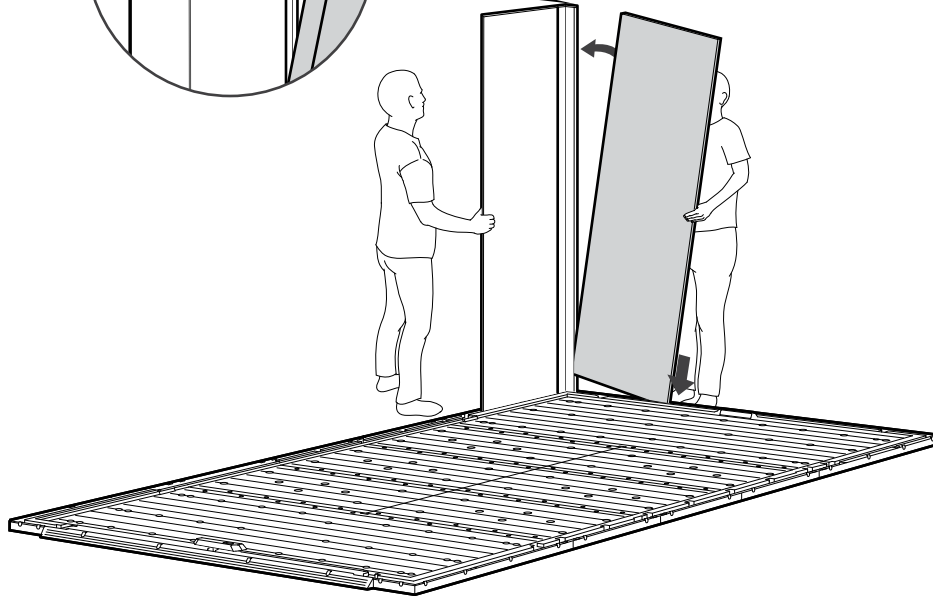
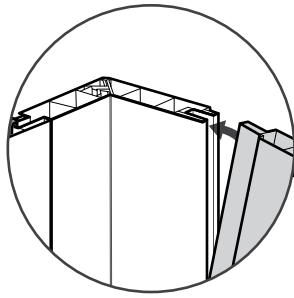
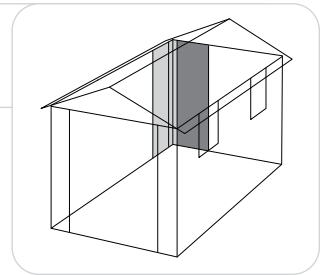

Front | Avant | Delante | Vorderseite |
Voorkant | Anteriore | Frenete

11



KP (x1)



s13b (x1)

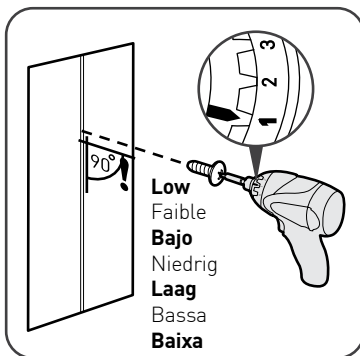
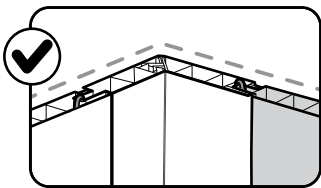
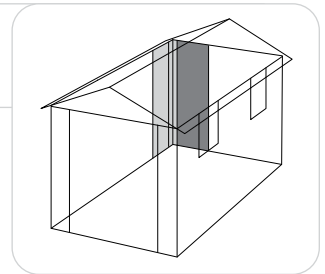

Low
Faible
Bajo
Niedrig
Laag
Bassa
Baixa

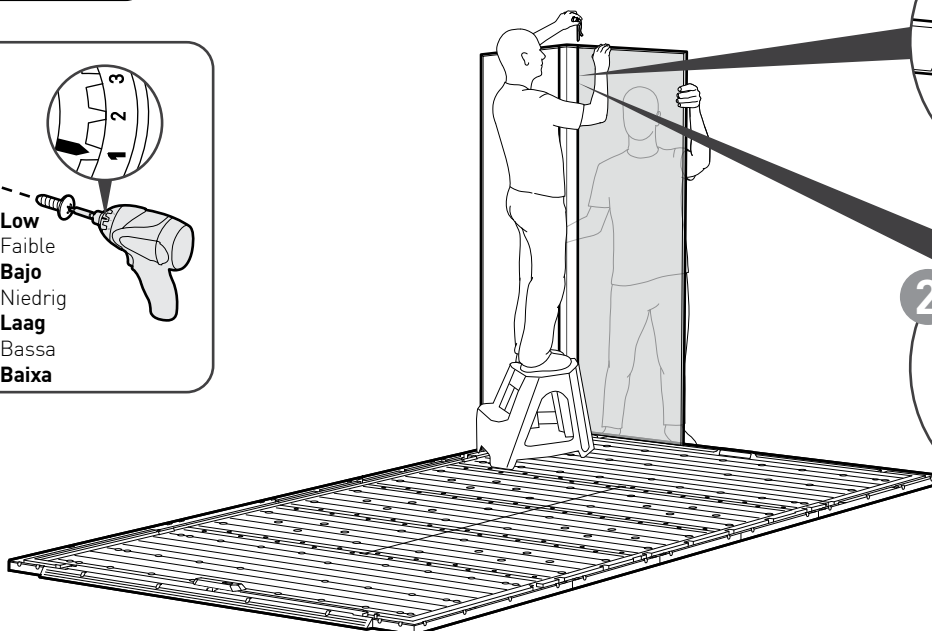
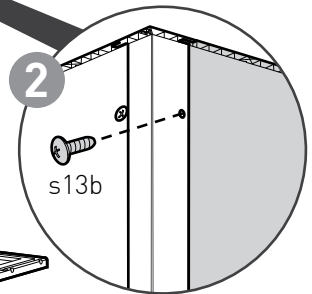
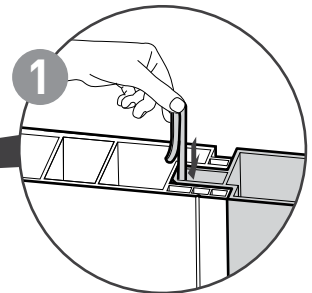

Front | Avant | Delante | Vorderseite |
Voorkant | Anteriore | Frenete

12



oLP7 (x2)



KP (x2)



s13b (x2)

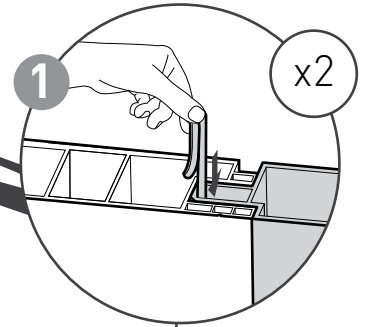
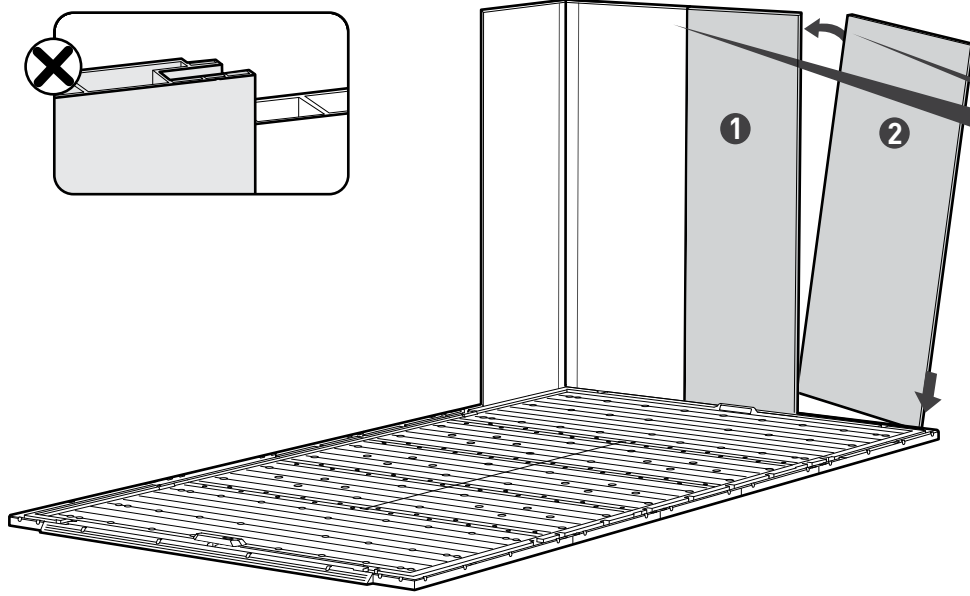
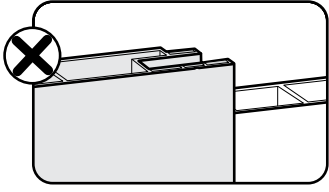
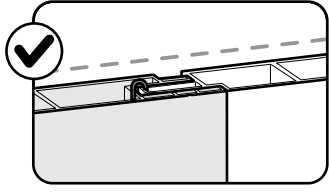
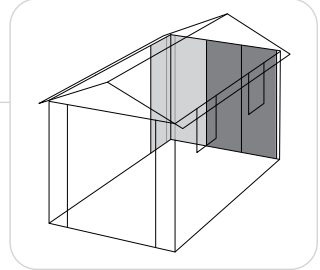

x2

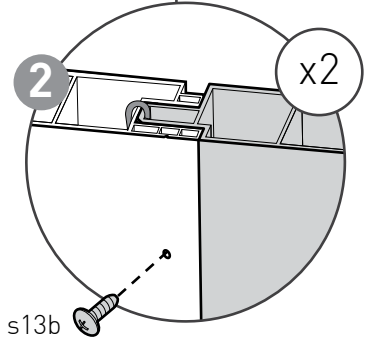

x2

s13b

Front | Avant | Delante | Vorderseite |
Voorkant | Anteriore | Frente

13



oLPC (x1)



KP (x1)

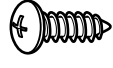

s13b (x1)

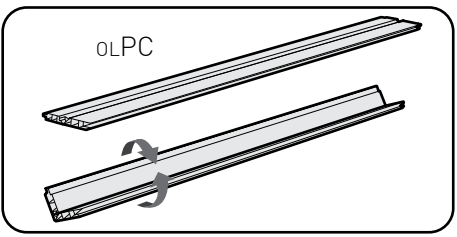
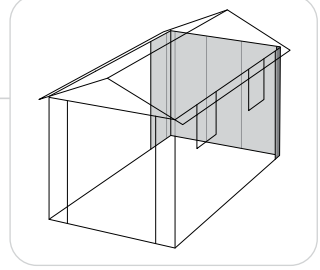

oLPC

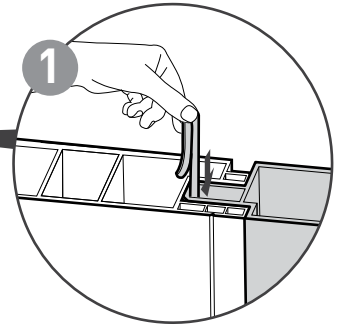
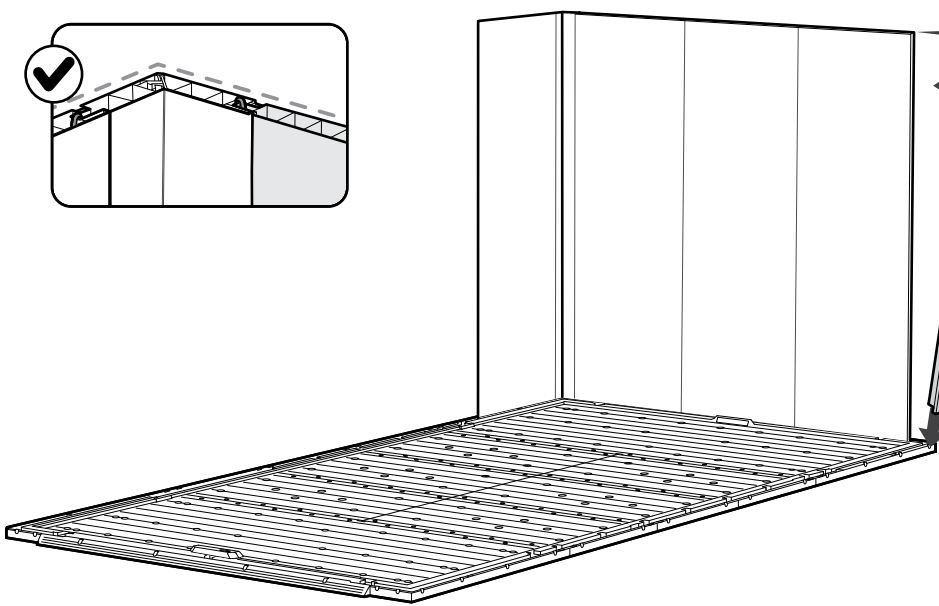
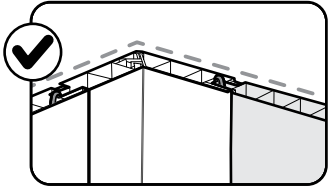

1

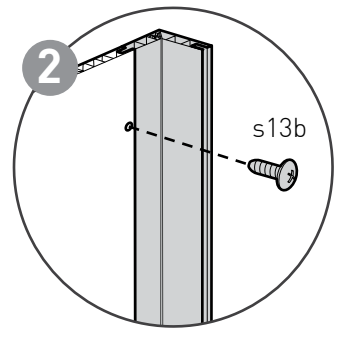

2

s13b

Front | Avant | Delante | Vorderseite |
Voorkant | Anteriore | Frente

14 |  oLP7 (x1) |  KP (x1) |  s13b (x1) |  

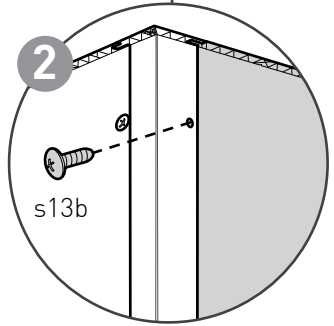
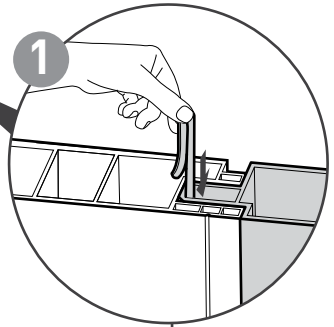
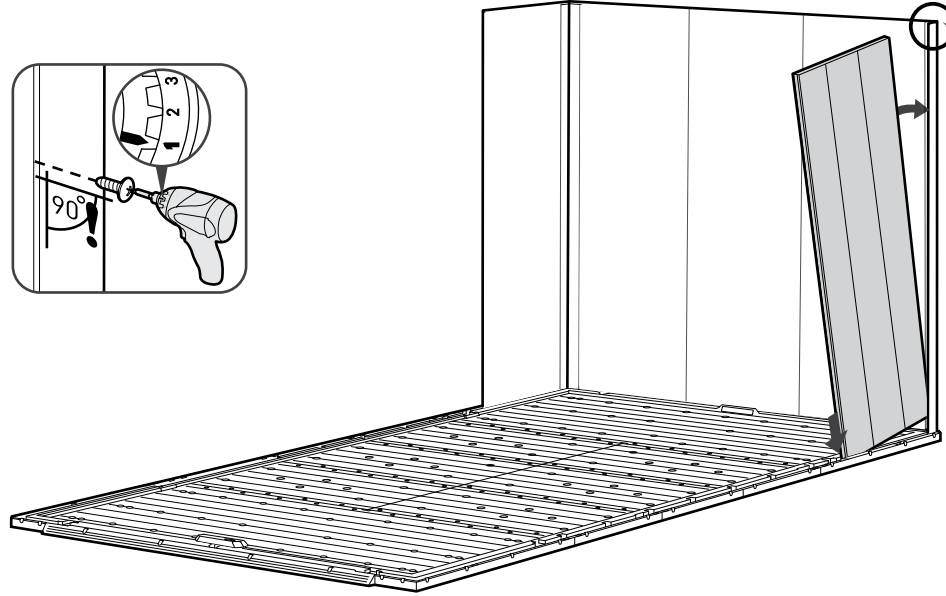
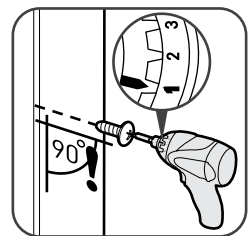
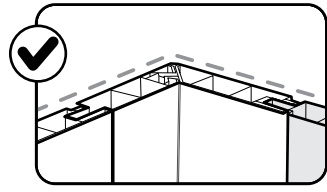

Front | Avant | **Delante** | Vorderseite |
Voorkant | Anteriore | **Frente**

Choose the location of the window | Choisissez l'emplacement de la fenêtre | **Elija dónde quiere colocar la ventana** | Wählen sie aus, wo sie das fenster anbringen möchten | **Kies waar u het venster wilt hebben** | Scegliere la posizione della finestra | **Escolha onde quer colocar a janela**



<p>(A)</p>	<p>(B)</p>	<p>(C)</p>
<p>(D)</p>	<p>(E)</p>	<p>(F)</p>

15



oLPW (x1)



s13b (x1)

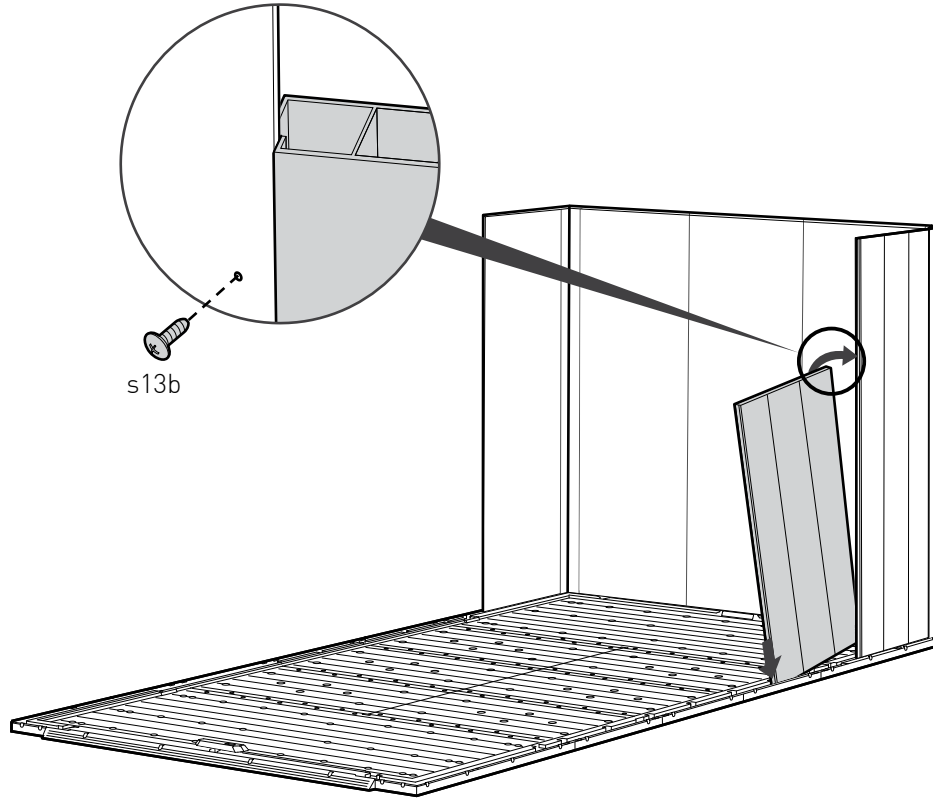
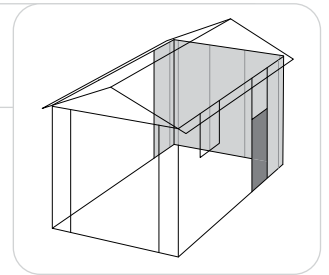

Front | Avant | Delante | Vorderseite |
Voorkant | Anteriore | Frenete

16



oLP7 (x3)



KP (x2)



s13b (x1)

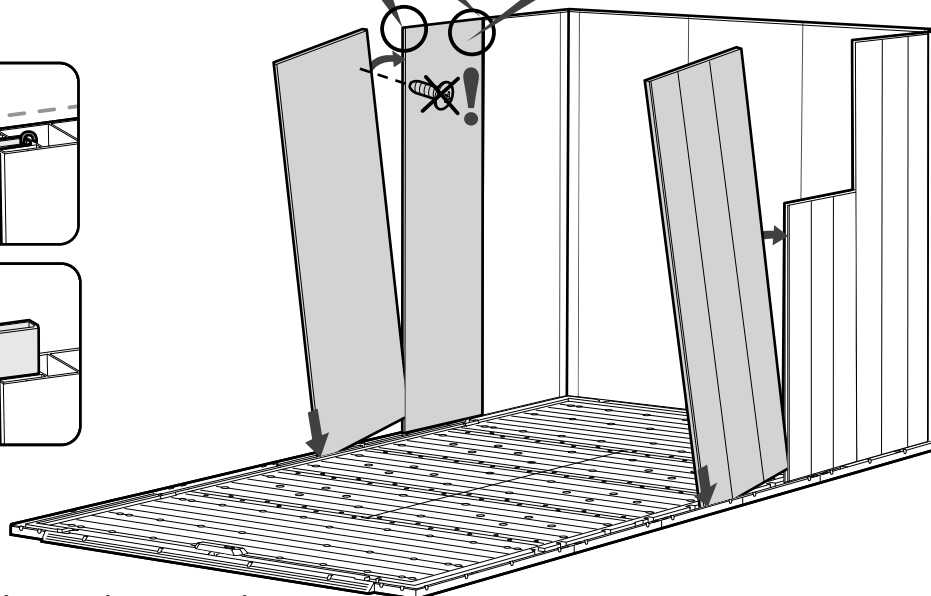
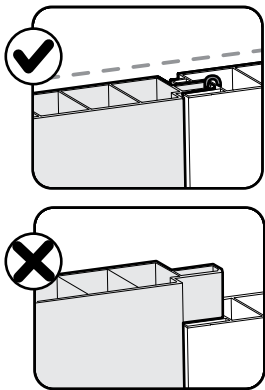
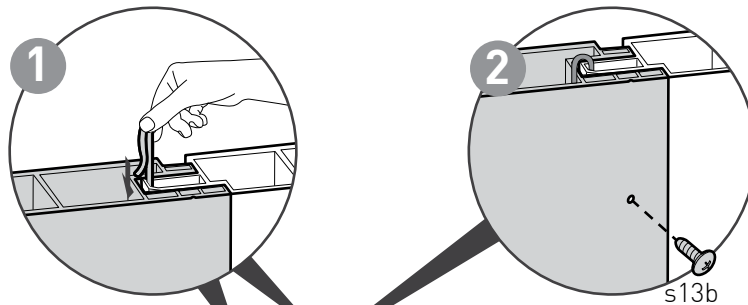
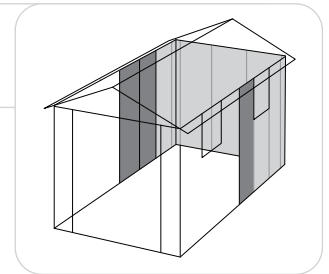

Front | Avant | Delante | Vorderseite |
Voorkant | Anteriore | Frenete

17



moWT (x2)



moWP (x4)

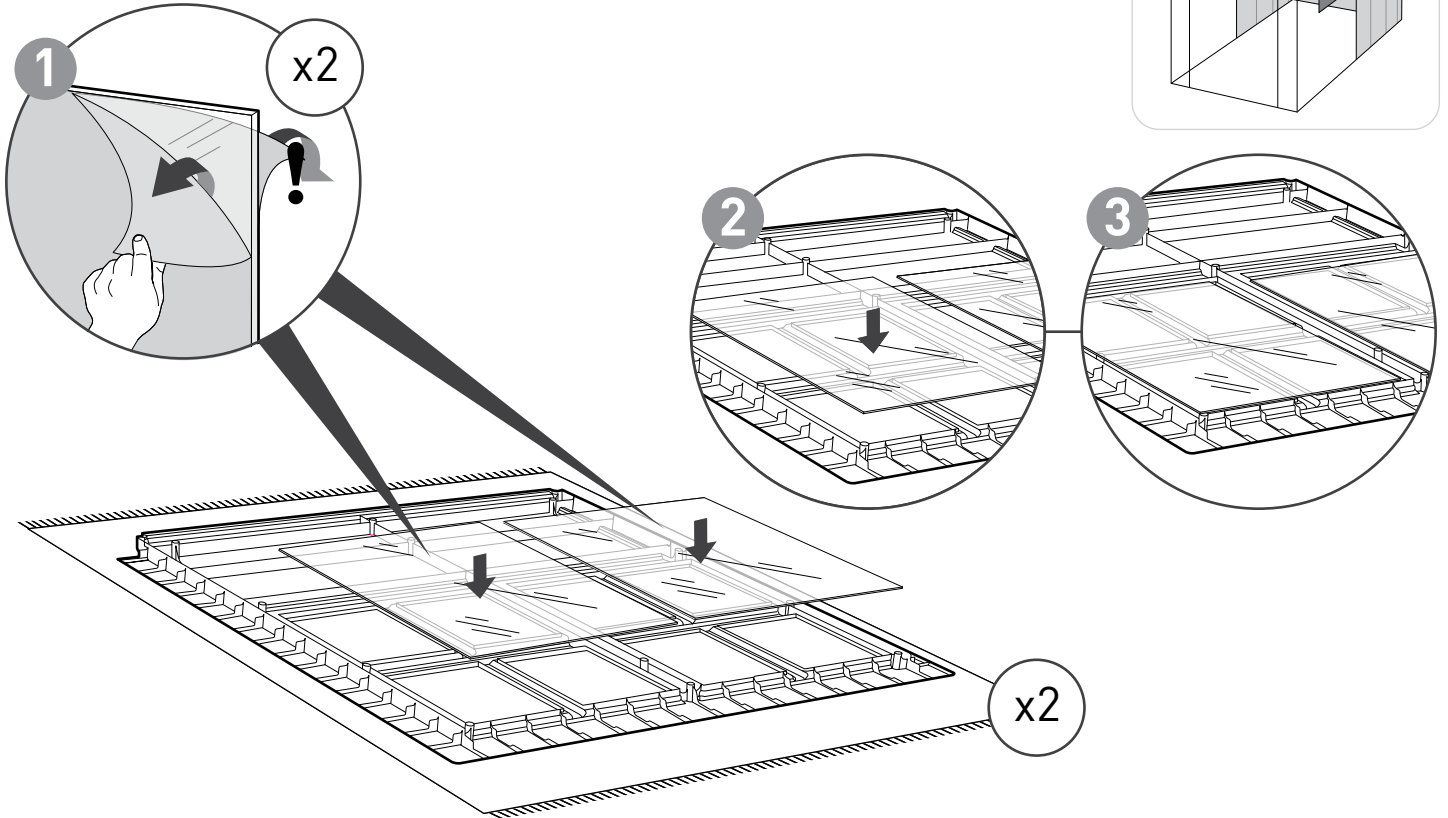
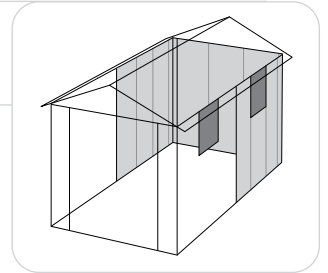

18



moWN (x2)



sc15 (x22)

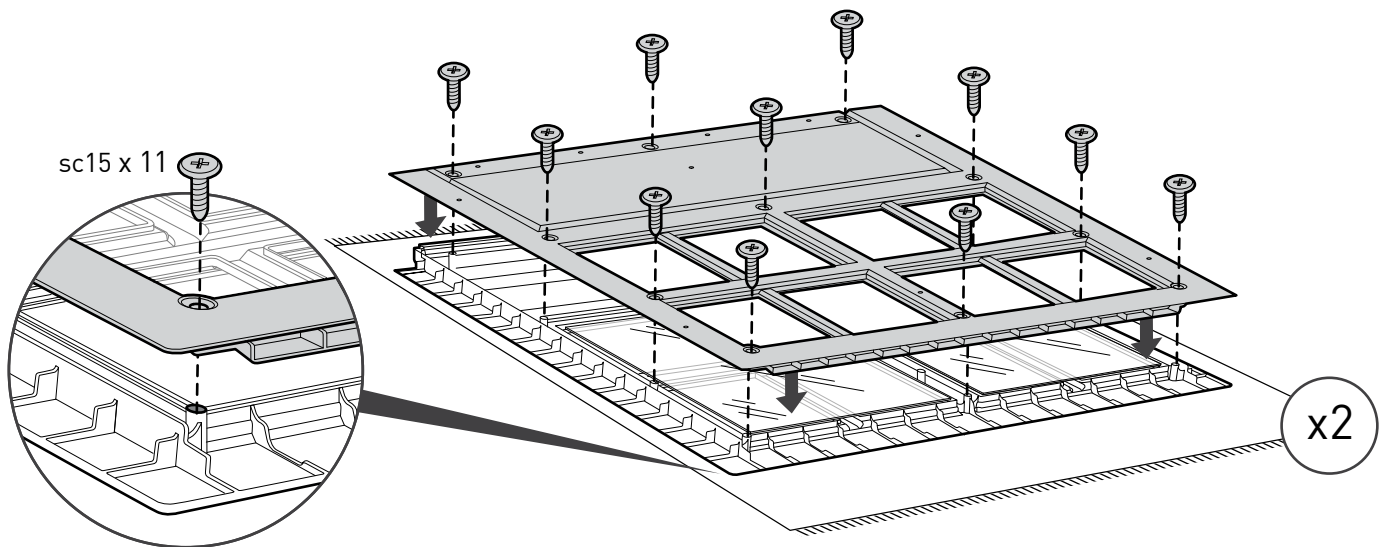
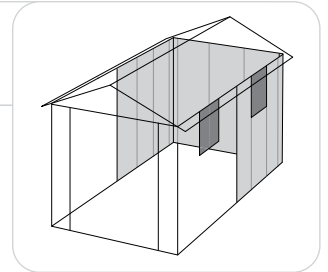

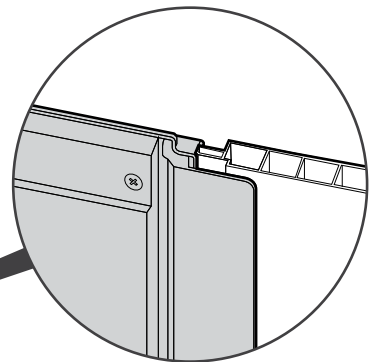
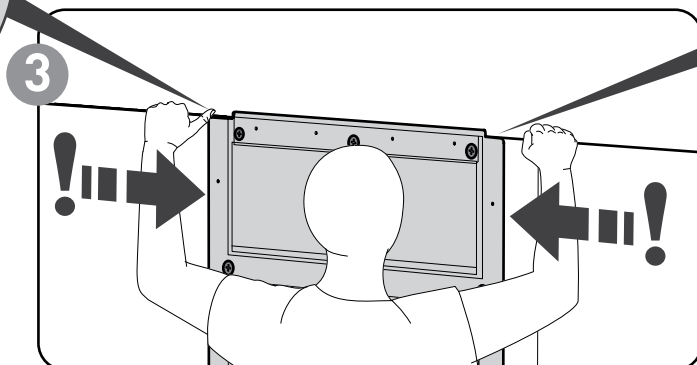
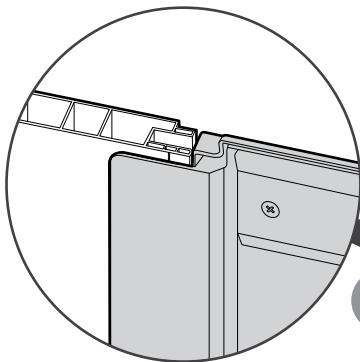
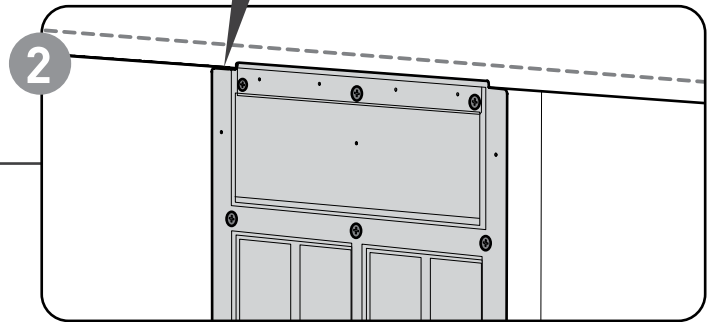
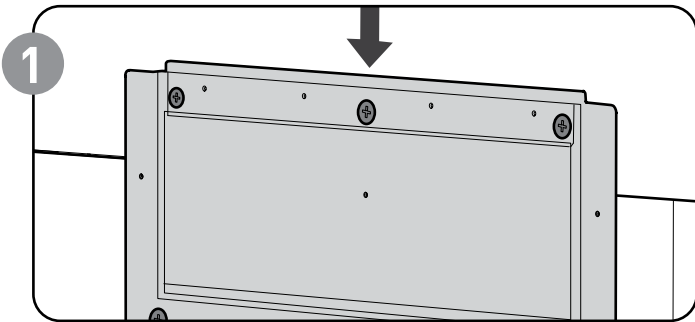
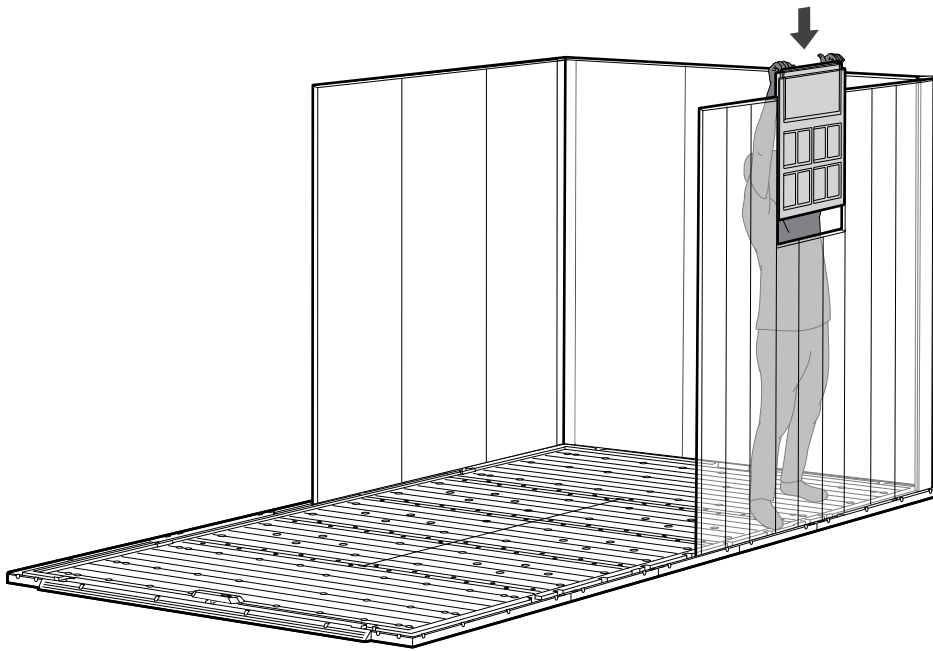
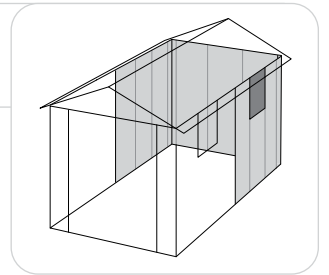

20



m0MP (x1)



sc15 (x1)

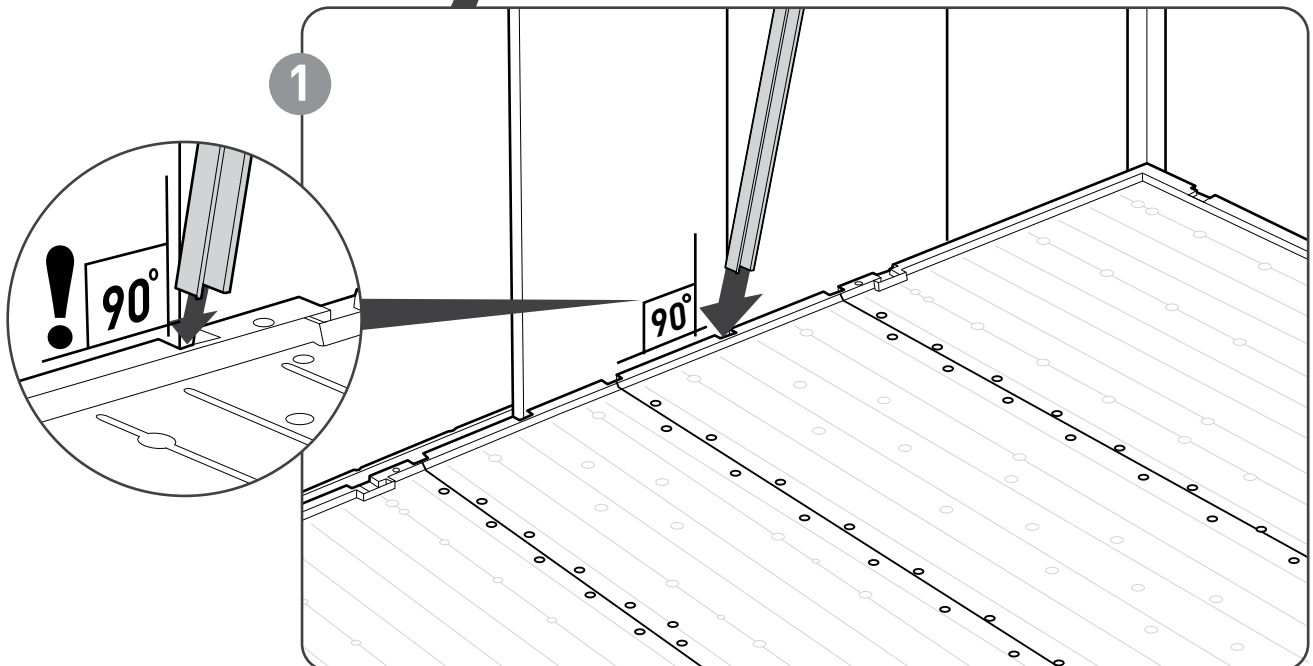
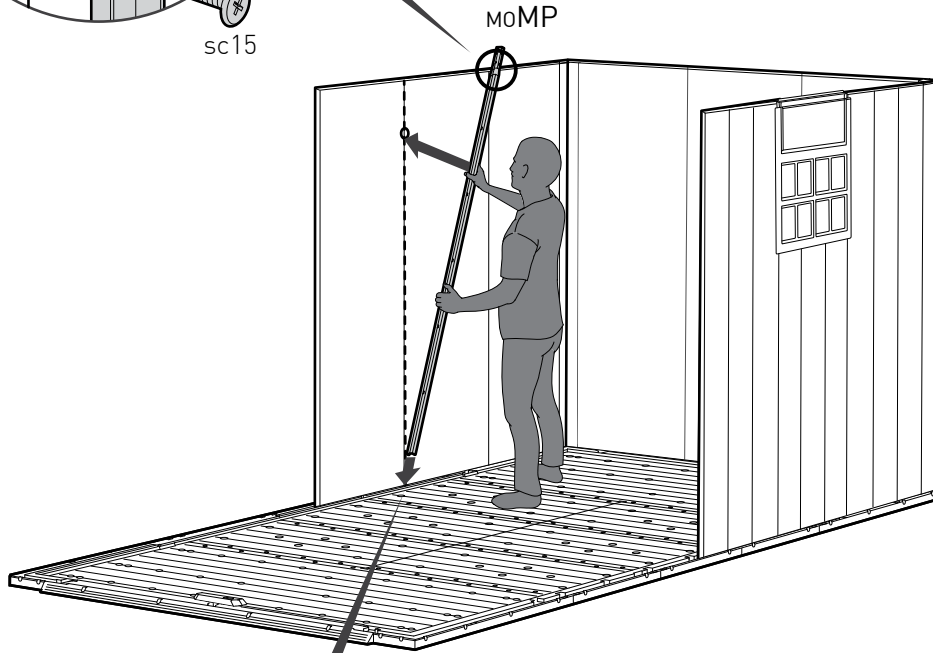
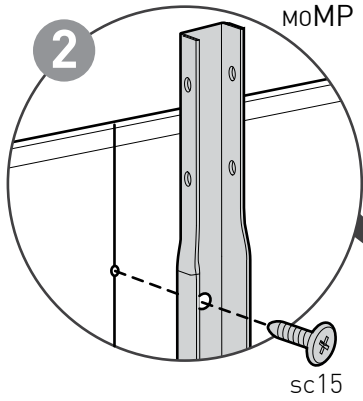
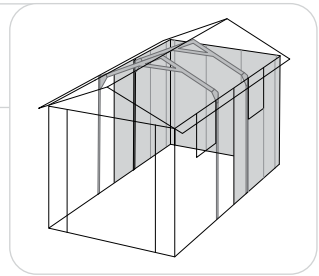

21



m0MP (x1)



sc15 (x1)

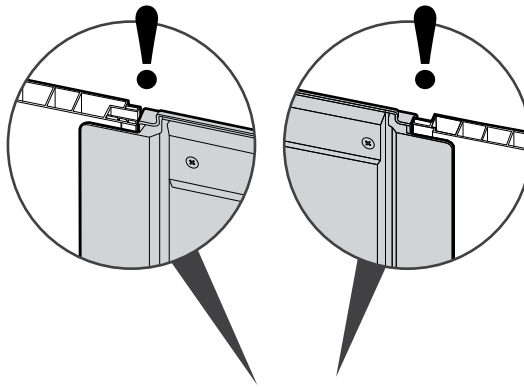
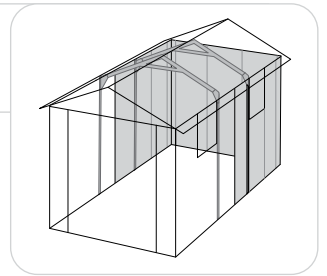

Pre-drilled holes

Trous pré-perçés

Agujeros pretaladrados

Vorgebohrte Löcher

Voorgeboorde gaten

Predisposizione per fori

Orificios pré-perforados

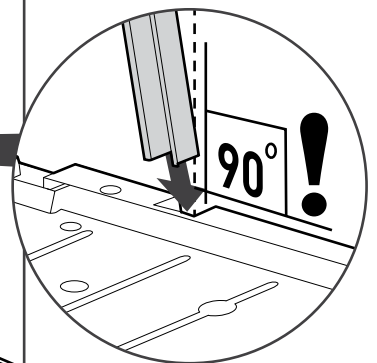
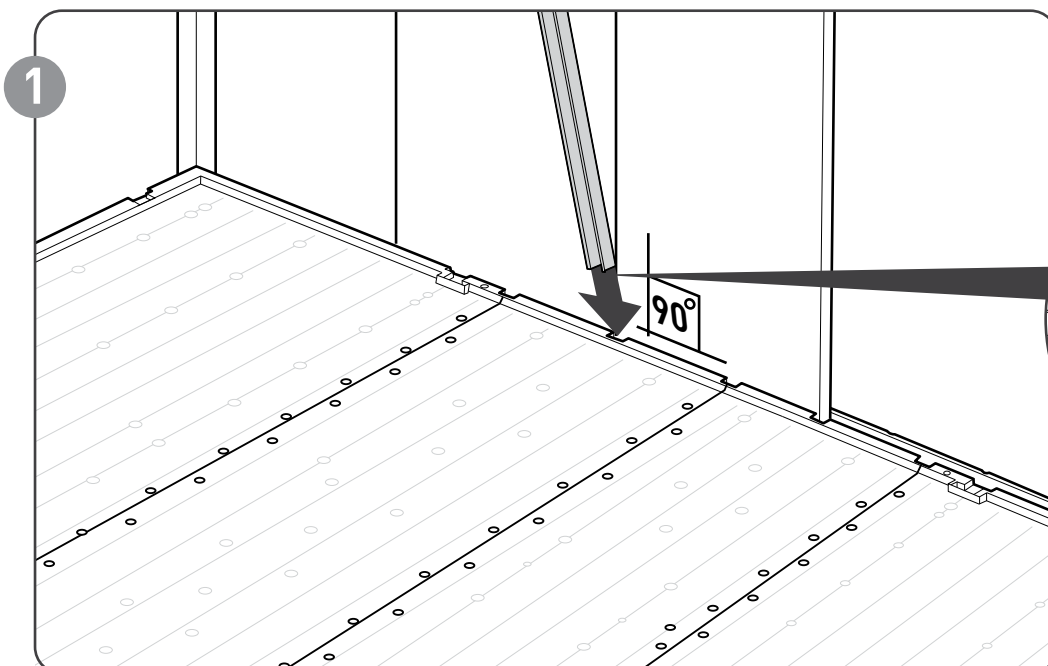
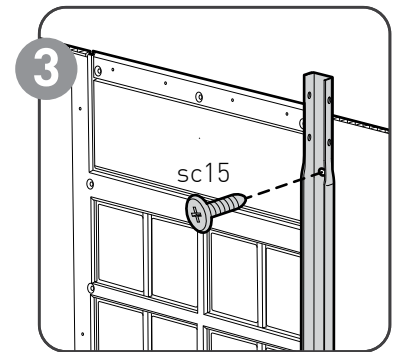
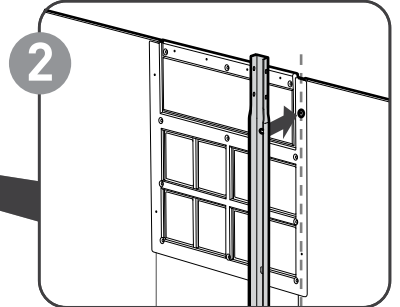
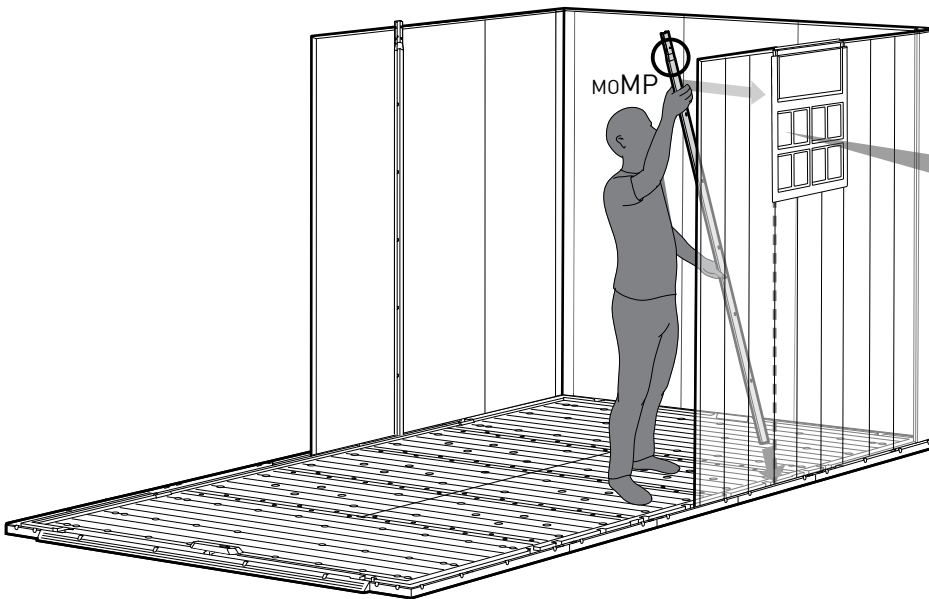

22

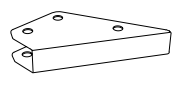

FNME (x2)



sc8 (x2)



scn8 (x2)

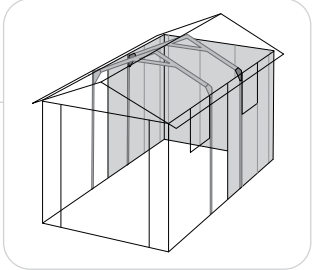

1

FNME

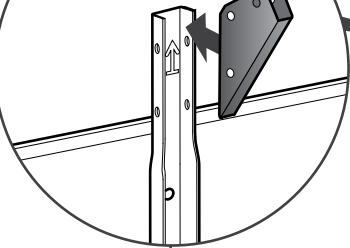

1

FNME

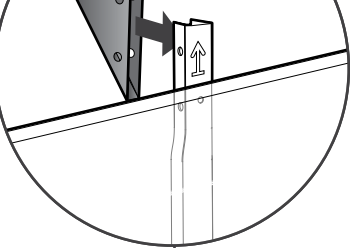

2

scn8

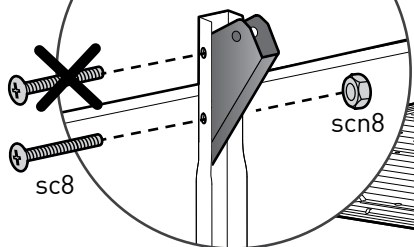

2

scn8

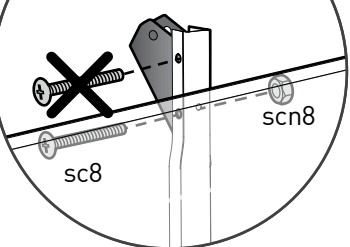

23

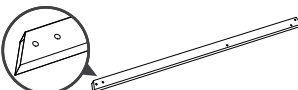

moMG (x4)

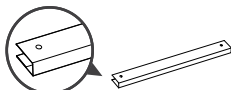

moMH (x2)

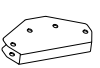

moMA (x2)

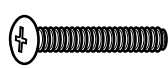

sc8 (x12)



scn8 (x12)

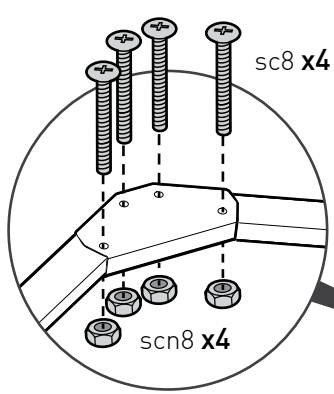
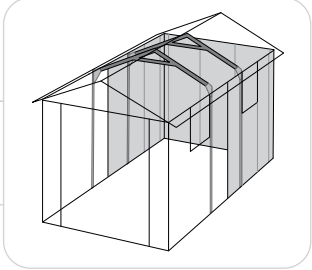

sc8 x4

scn8 x4

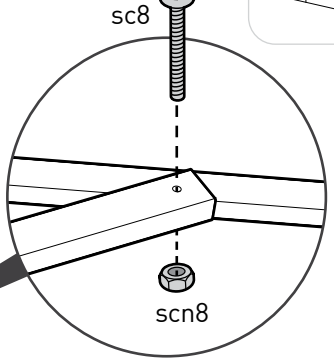

sc8

scn8

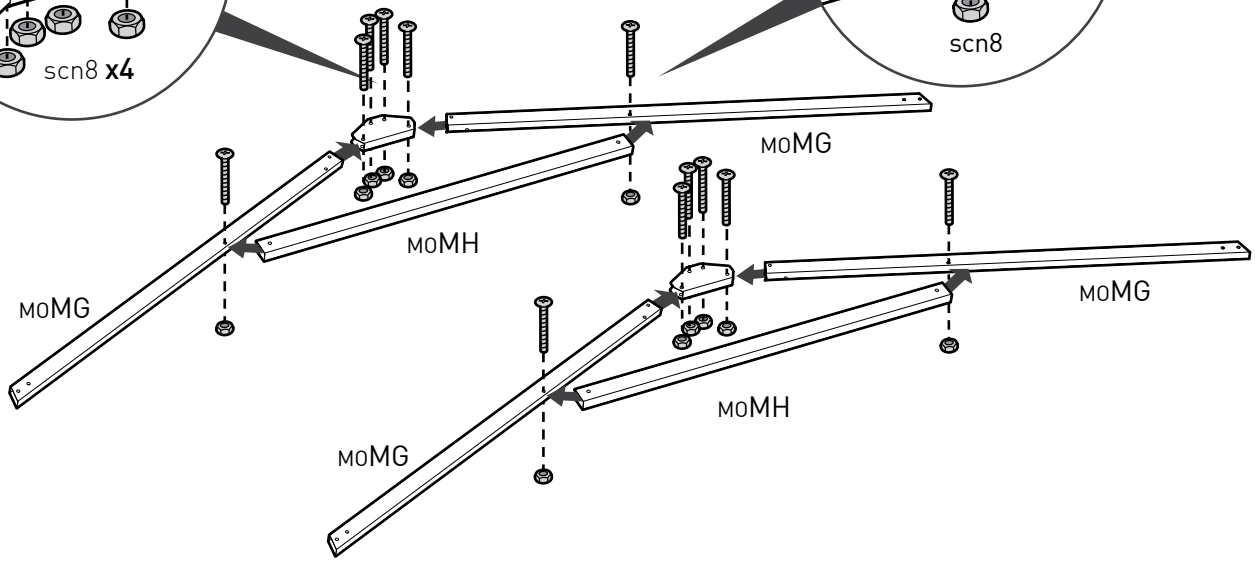

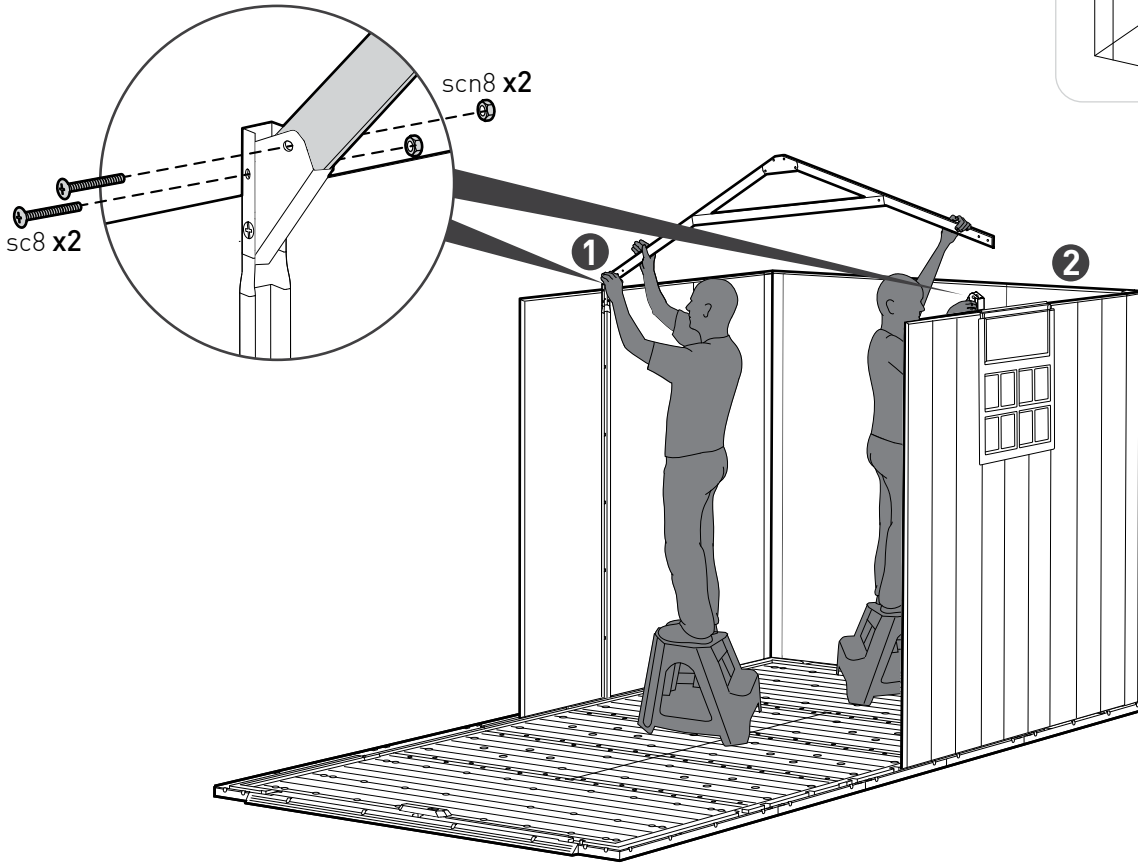
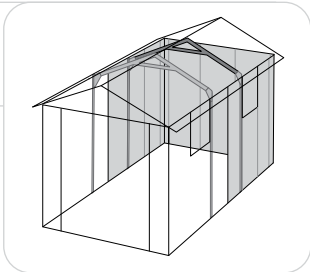
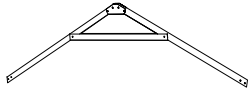

25



oLP7 (x5)

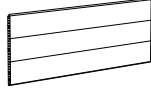

oLPW (x1)



KP (x4)



s13b (x4)

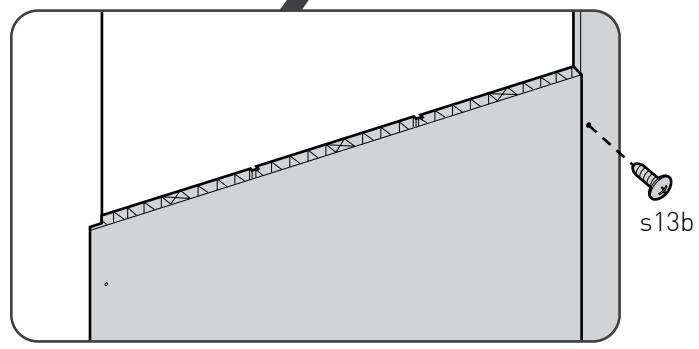
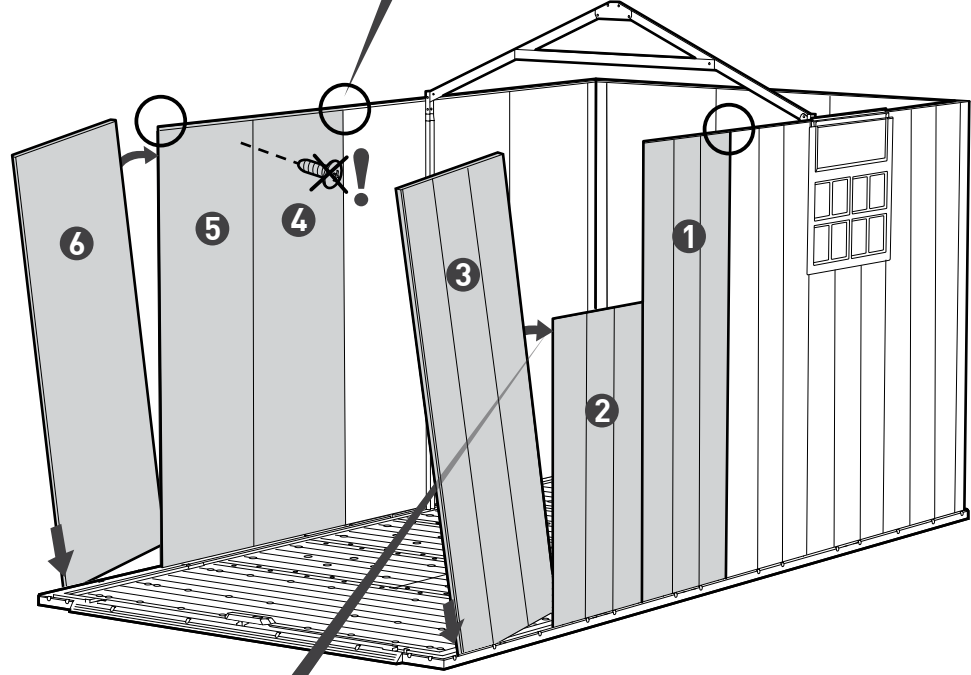
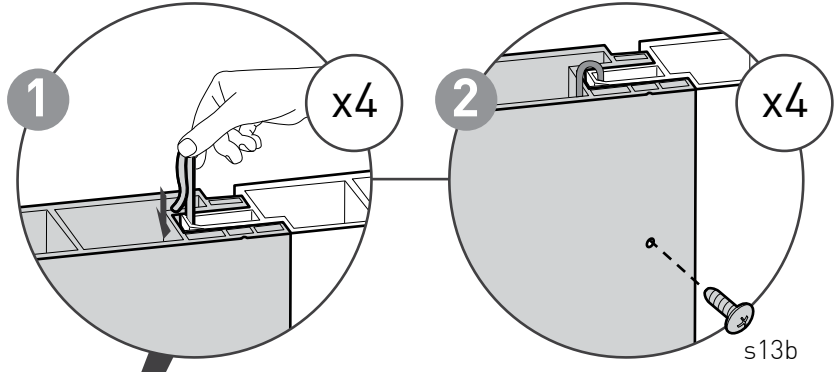
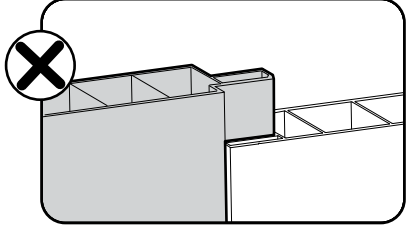
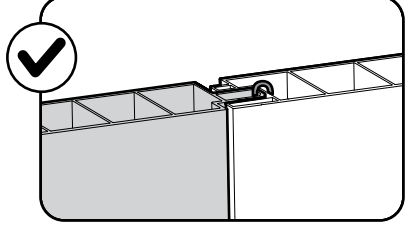
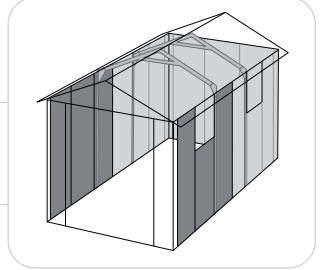

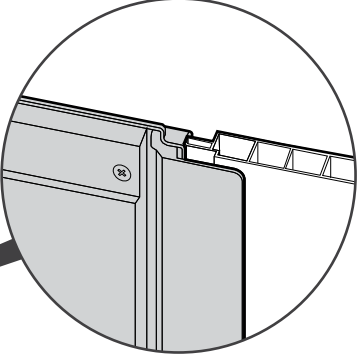
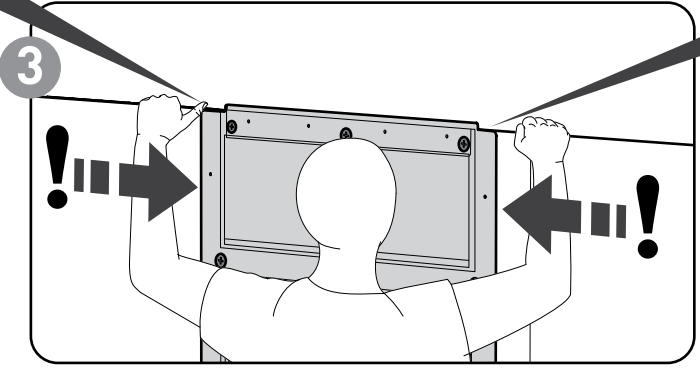
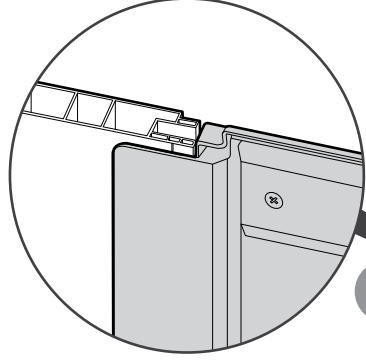
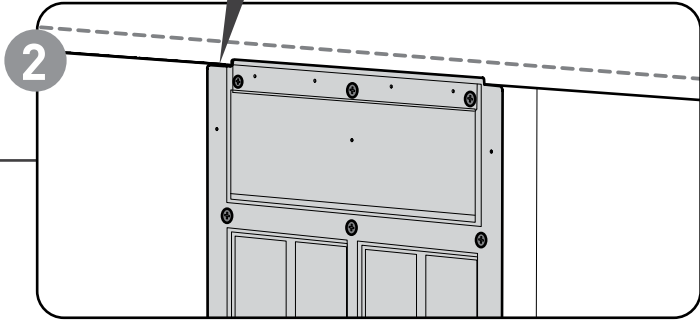
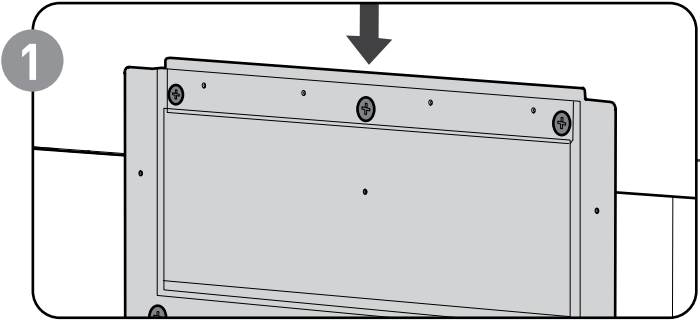
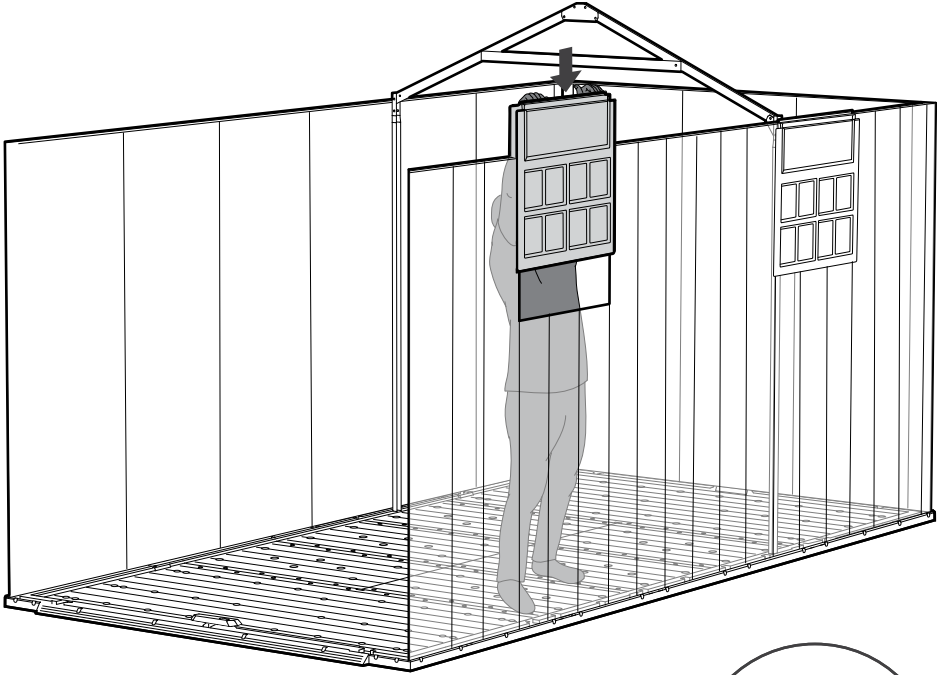
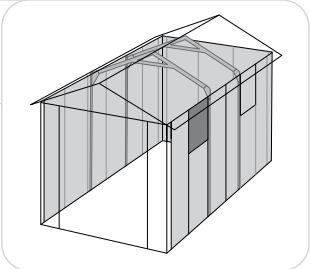

27



m0MP (x1)

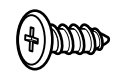

sc15 (x1)

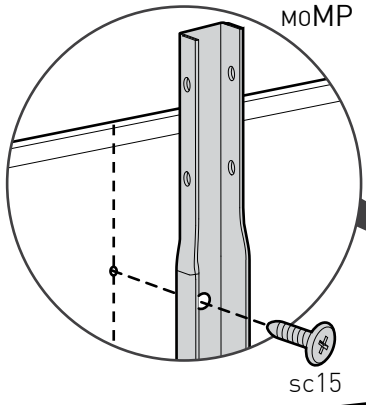
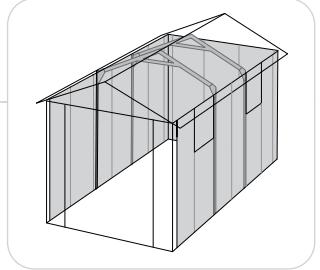

m0MP

sc15

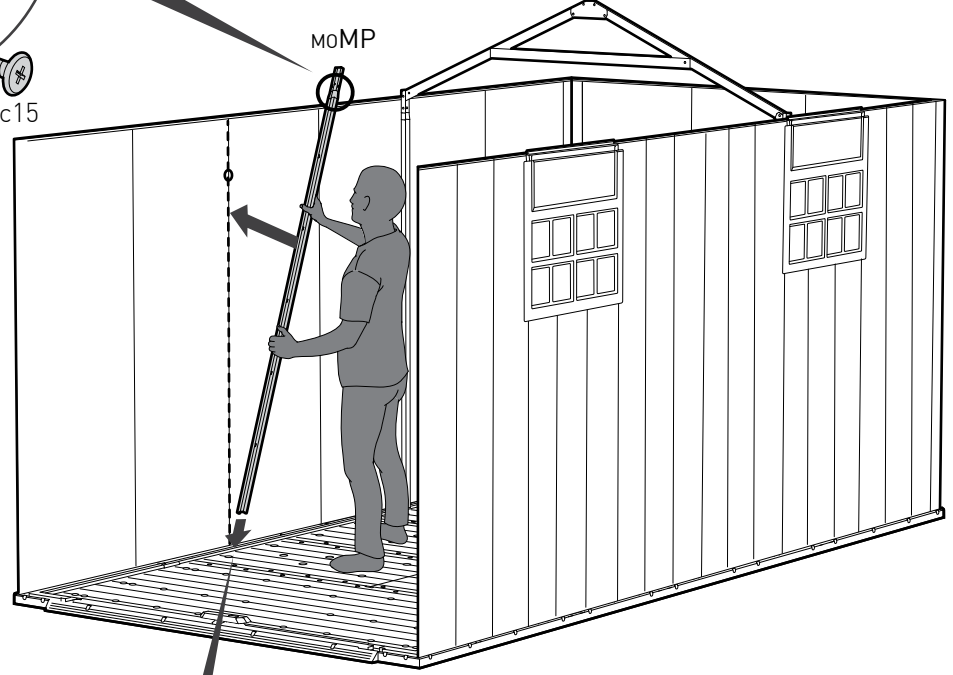

m0MP

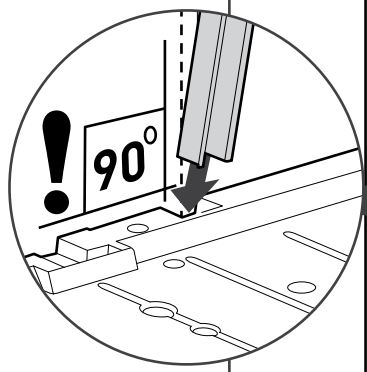

90°

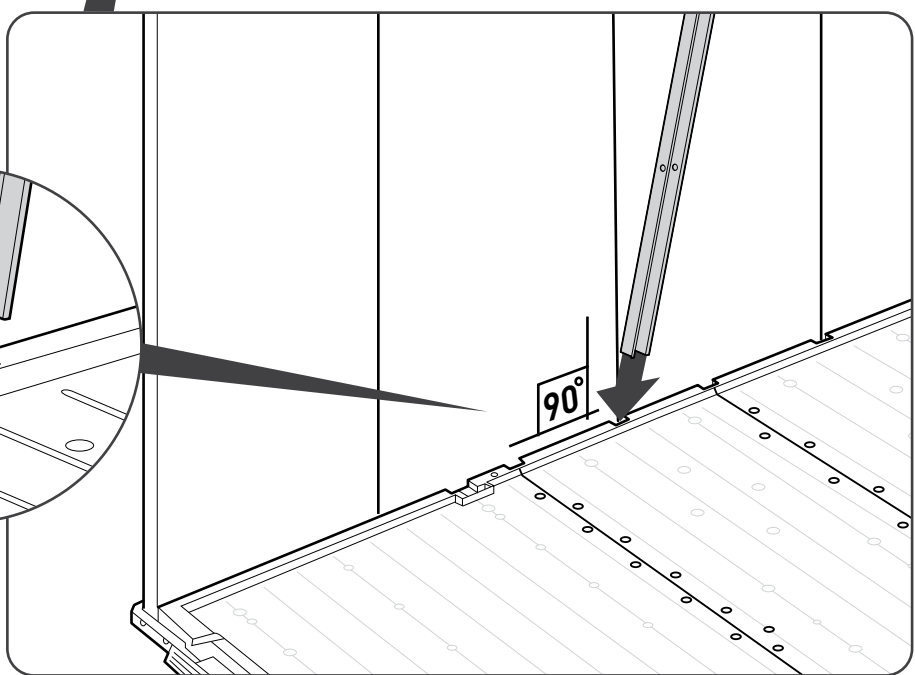

90°



moMP (x1)

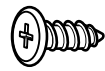

sc15 (x1)

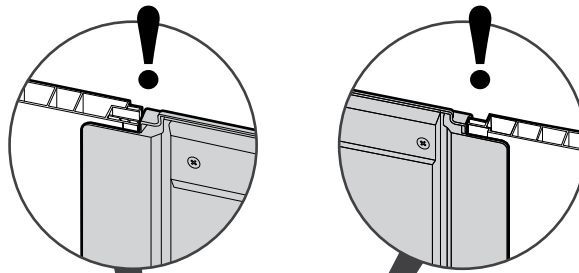
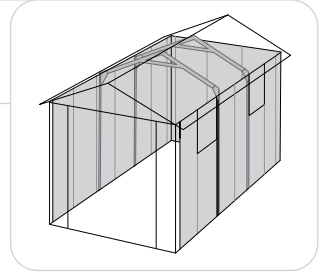
**Pre-drilled holes**

Trous pré-perçés

Agujeros pretaladrados

Vorgebohrte Löcher

Voorgeboorde gaten

Predisposizione per fori

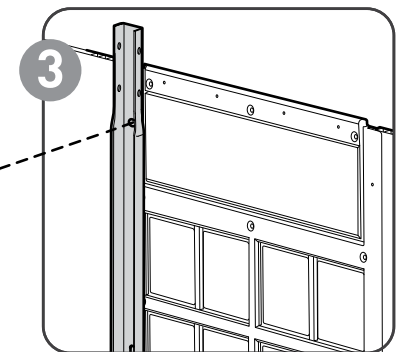
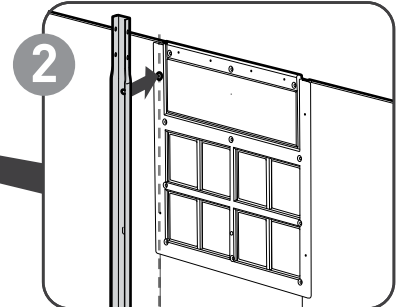
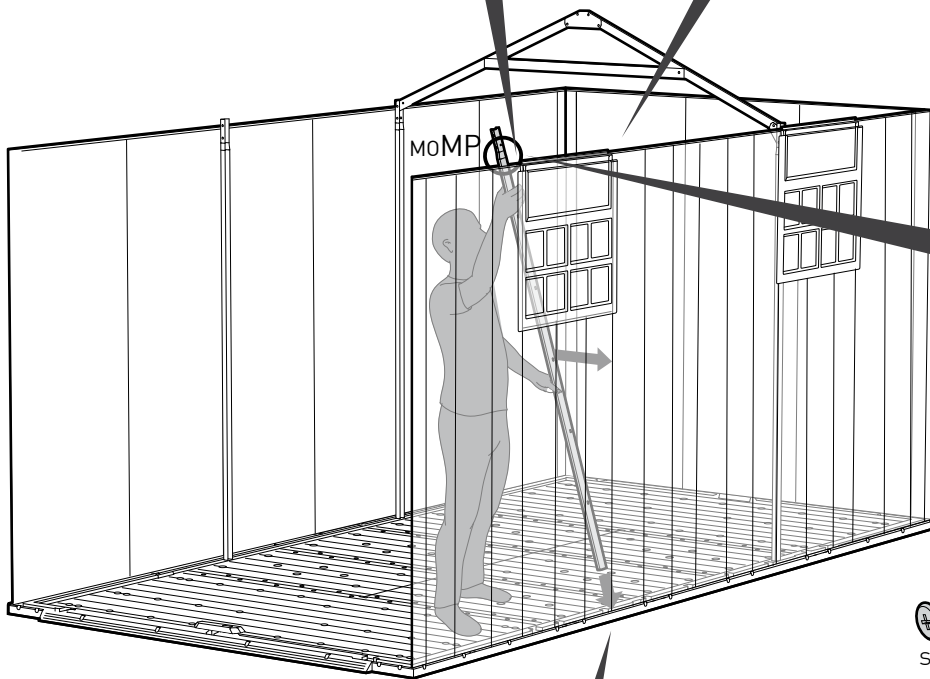
Orificios pré-perforados

sc15

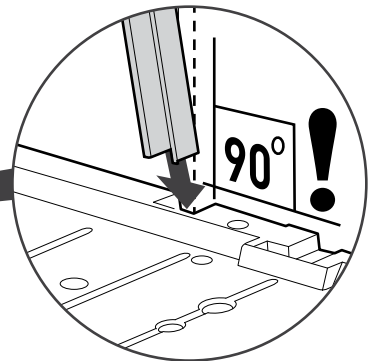
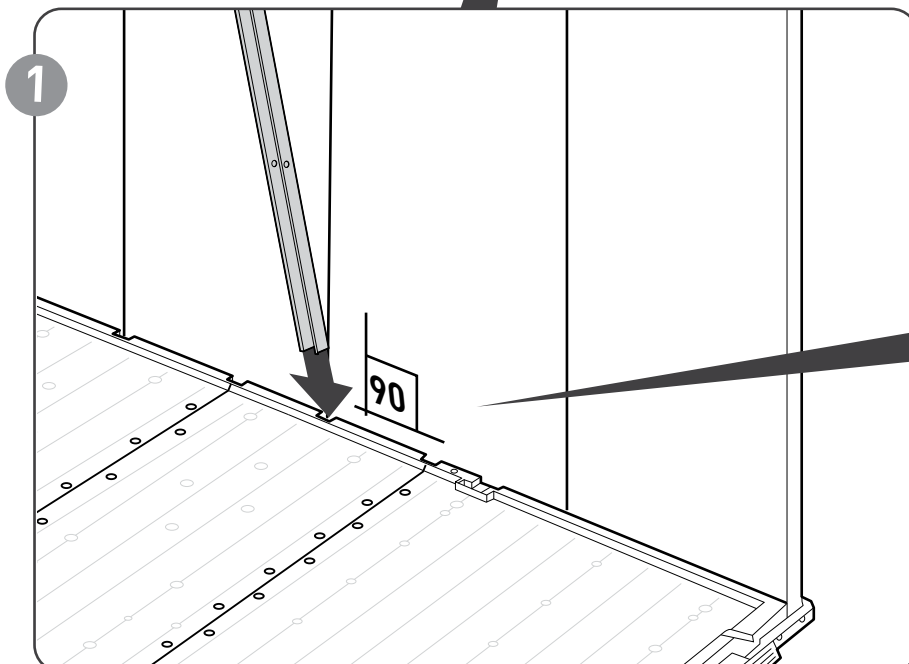

90°



29

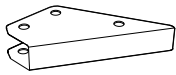

FNME (x2)



sc8 (x2)



scn8 (x2)

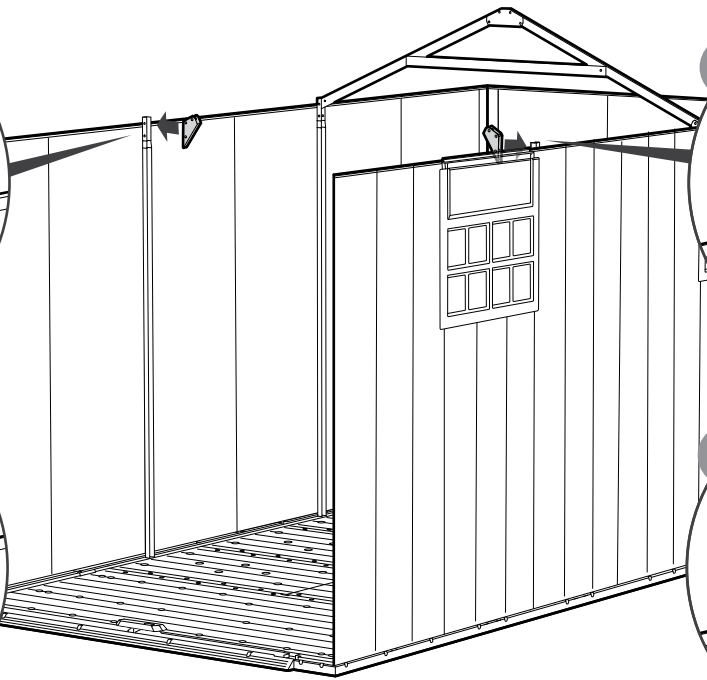
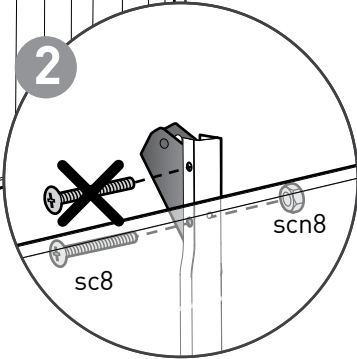
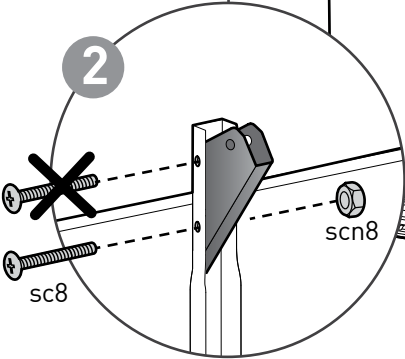
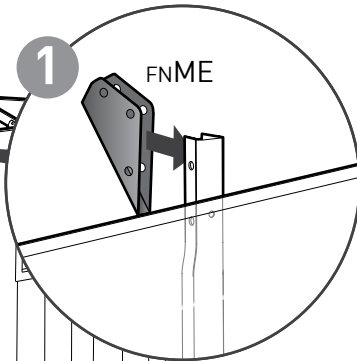
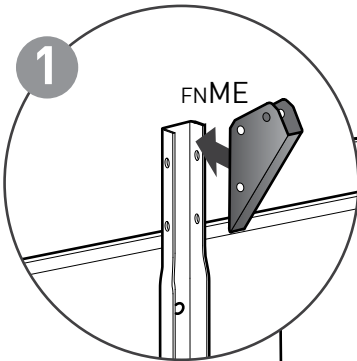
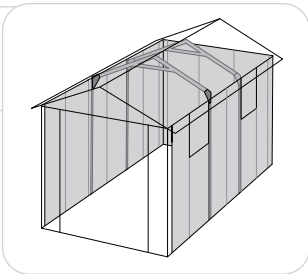

30

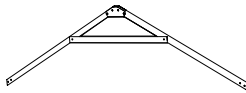

sc8 (x4)



scn8 (x4)

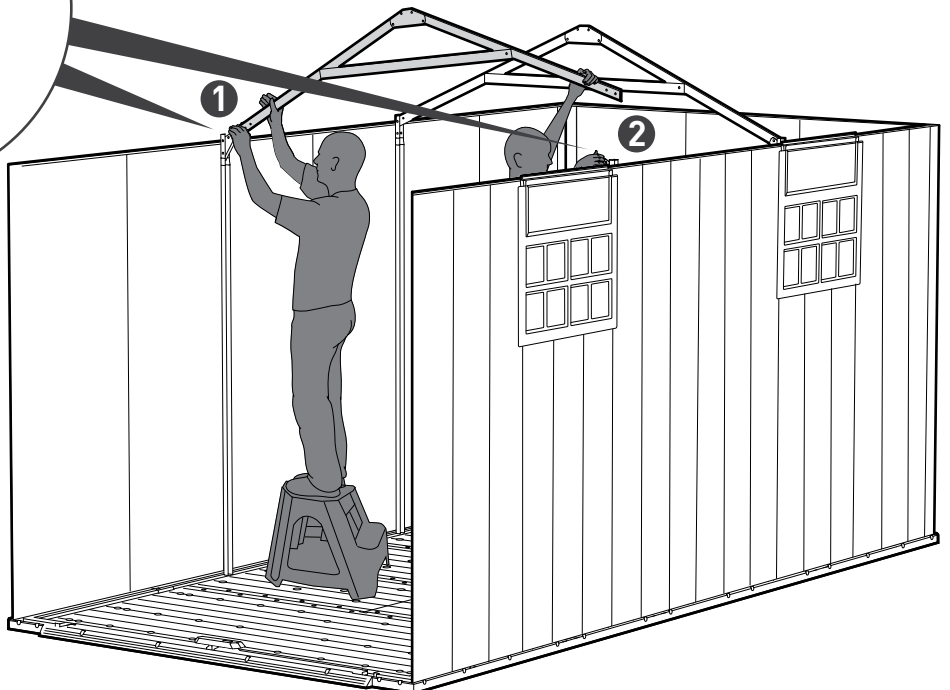
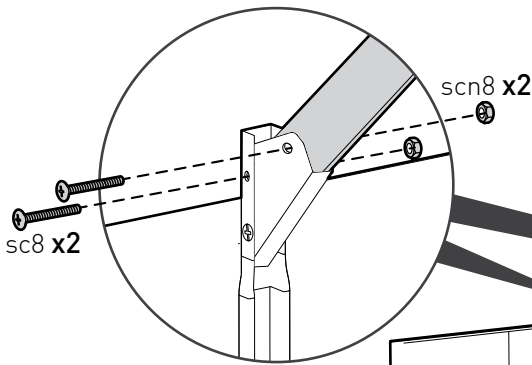
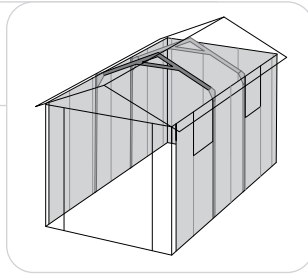

31



oLPC (x2)



KP (x2)

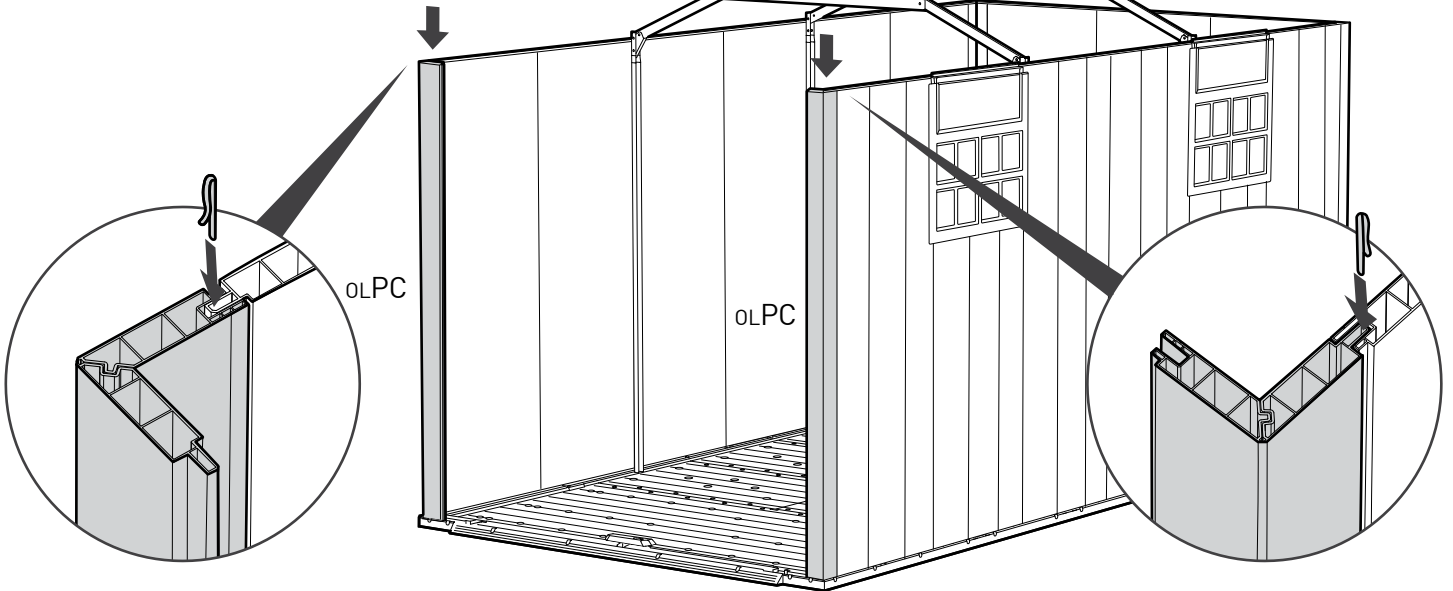
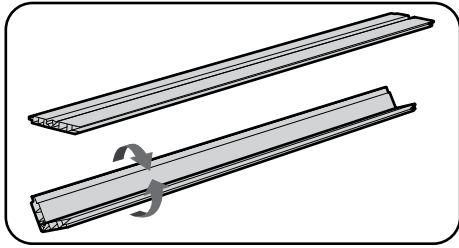
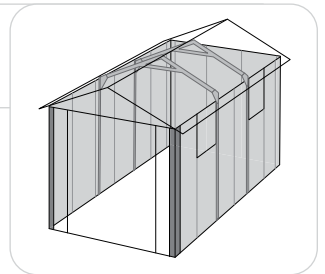

32

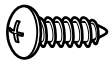

s13b (x4)

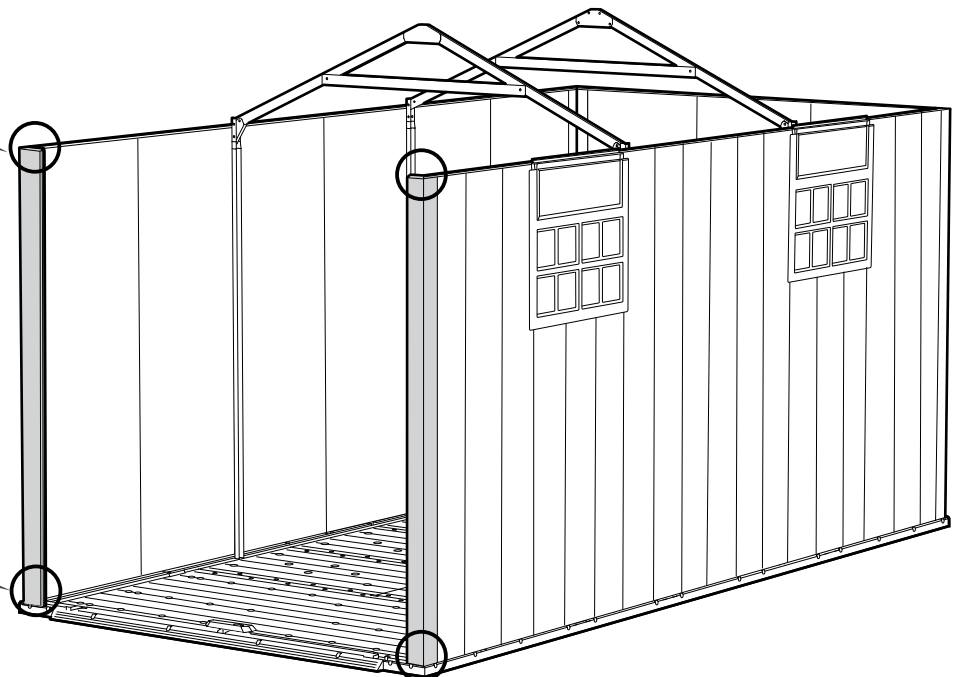
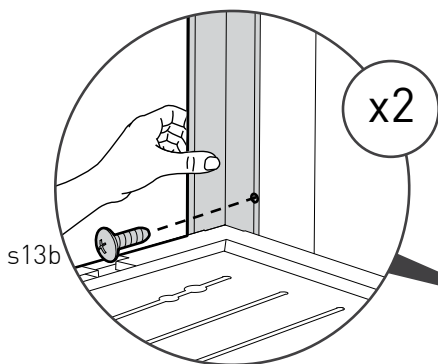
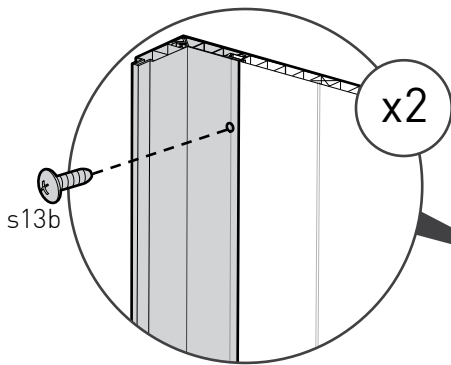
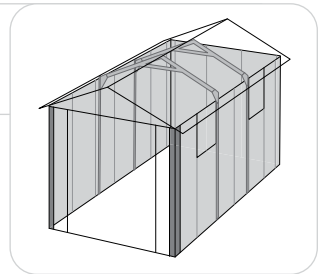

33

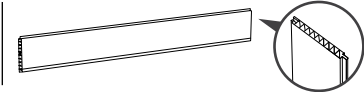

NEPF (x2)



KP (x2)

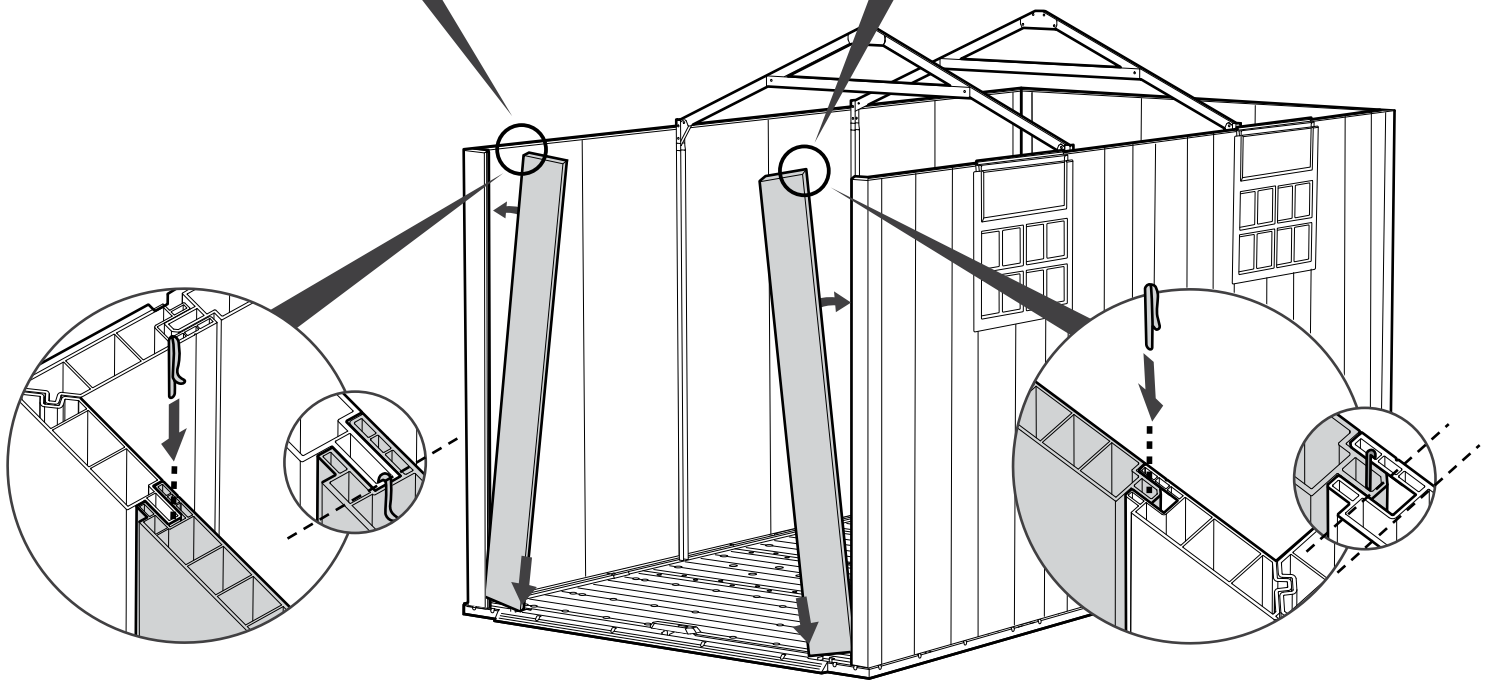
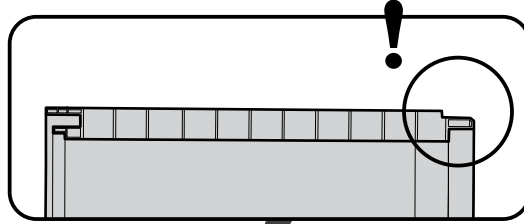
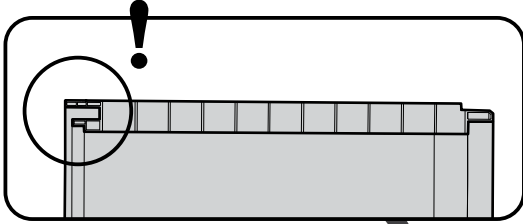
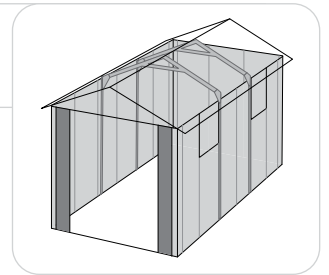

34



s13b (x4)

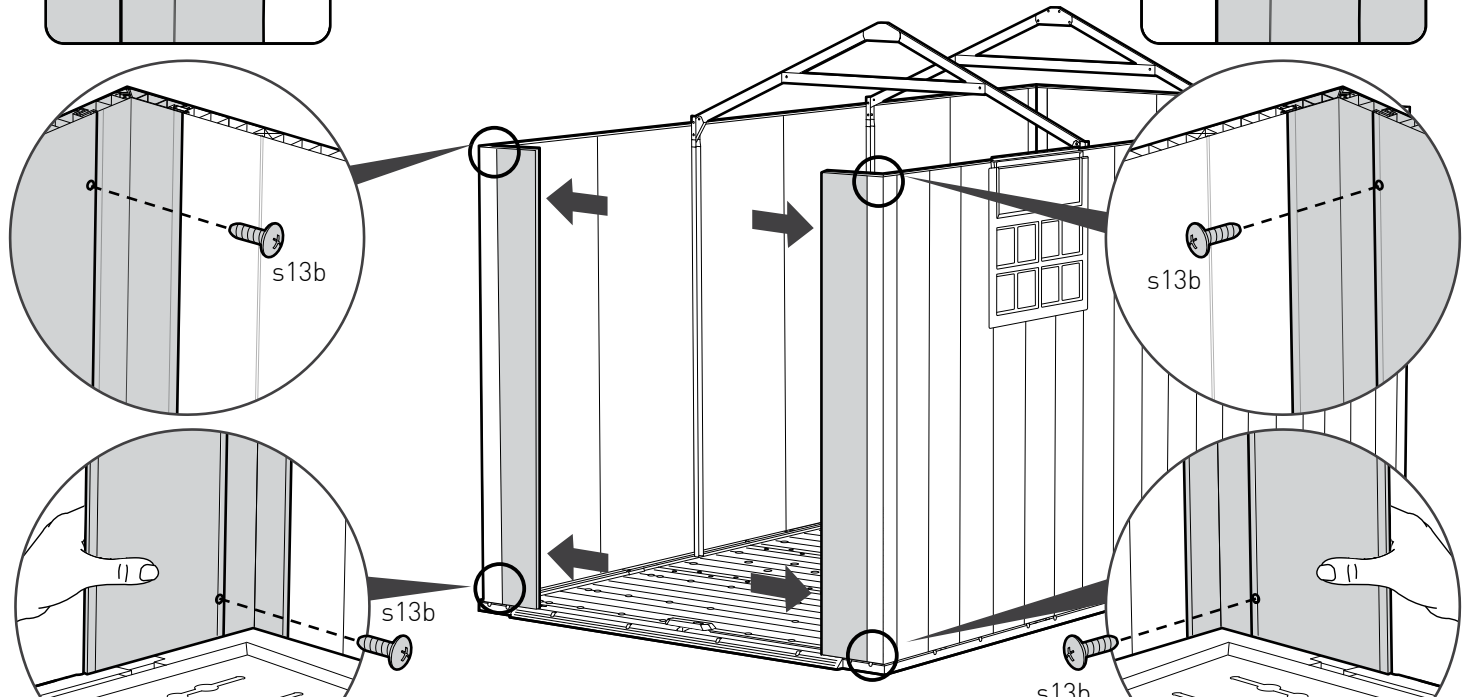
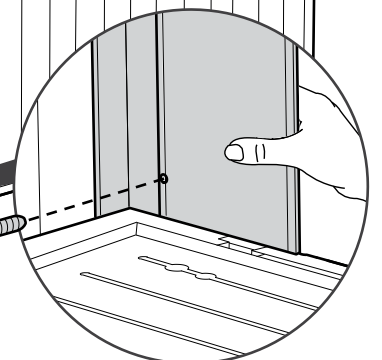
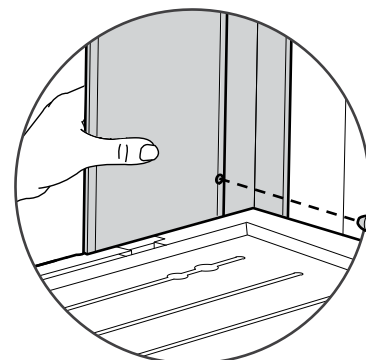
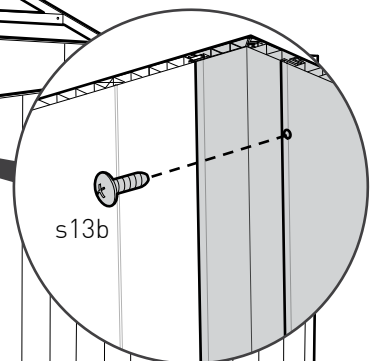
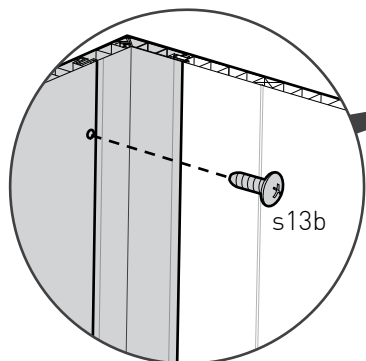
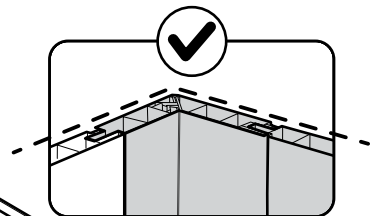
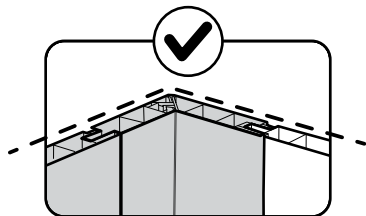



S45b (x2)

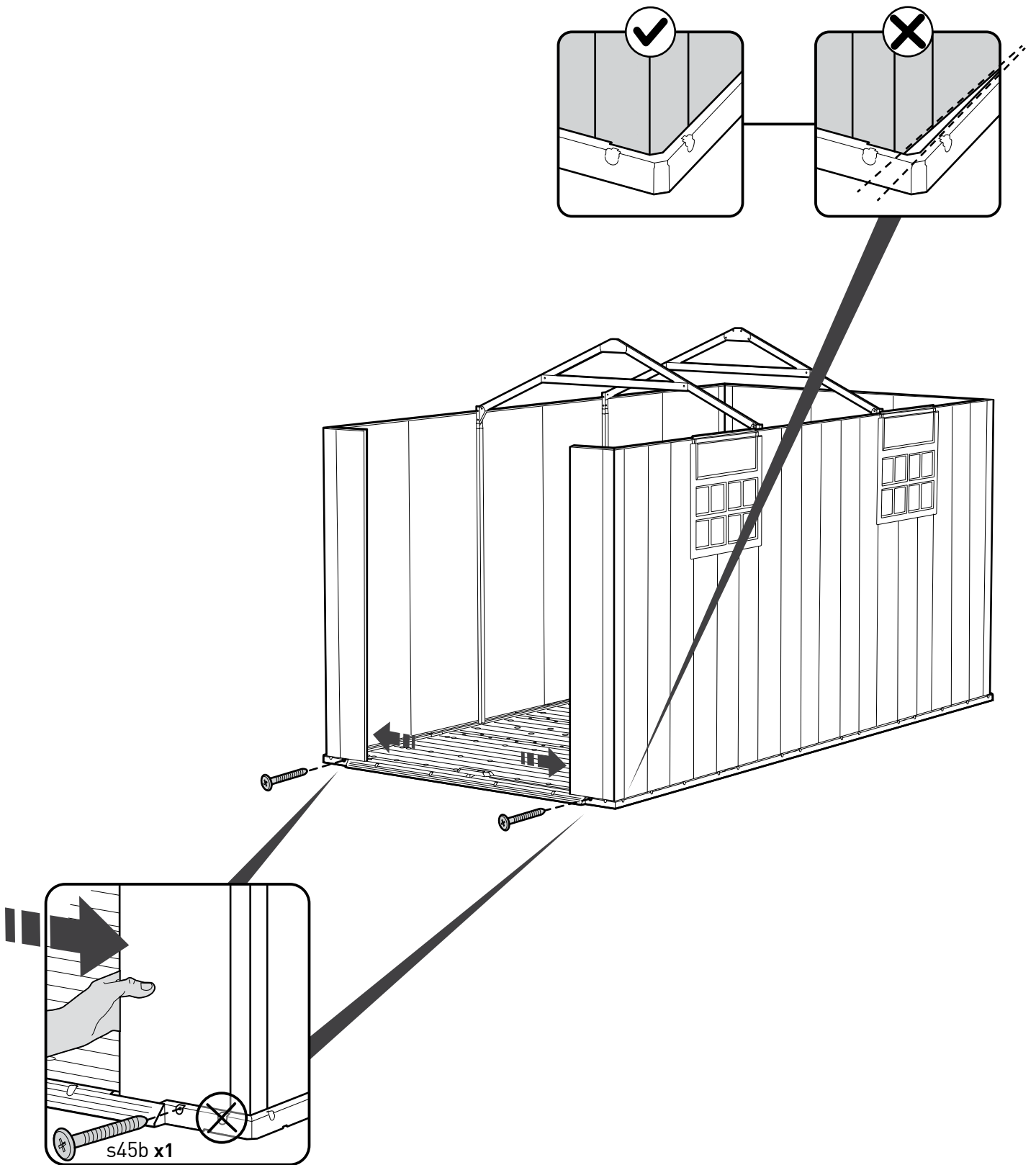

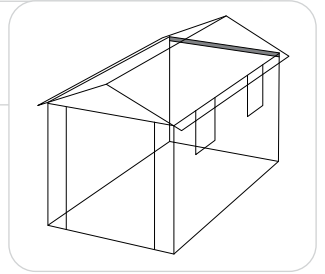
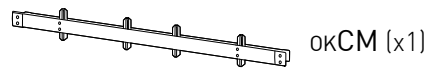
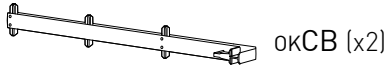

Inside | Intérieur | Interior | Innenseite |
Binnenkant | Interno | Interior

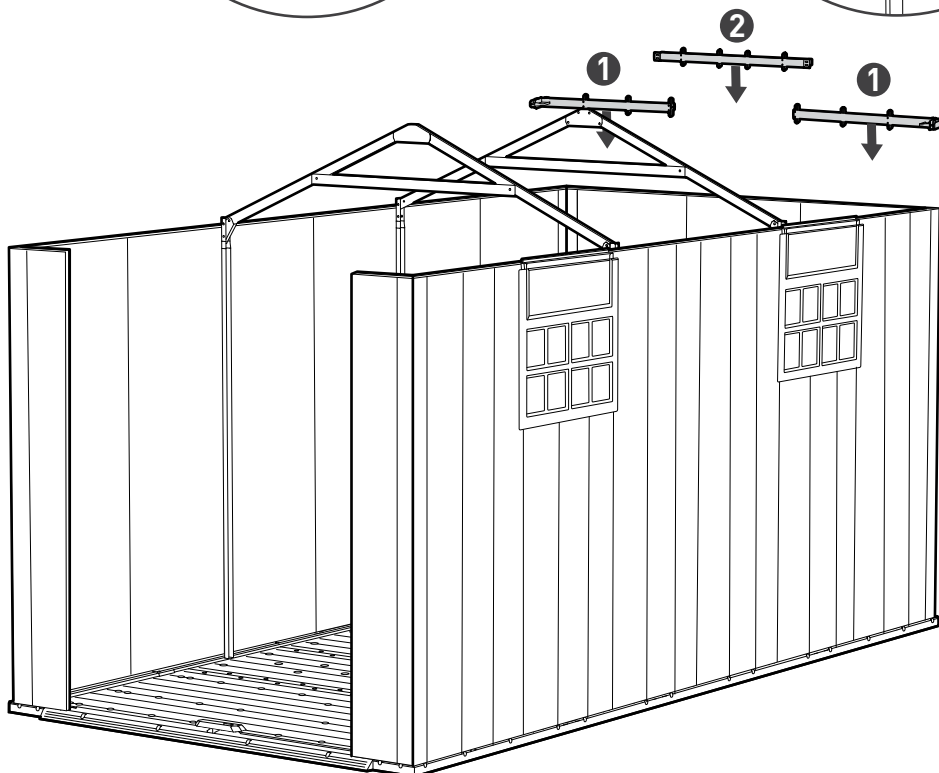
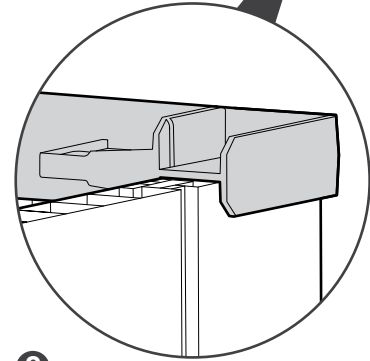
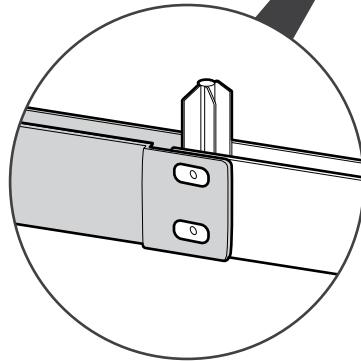
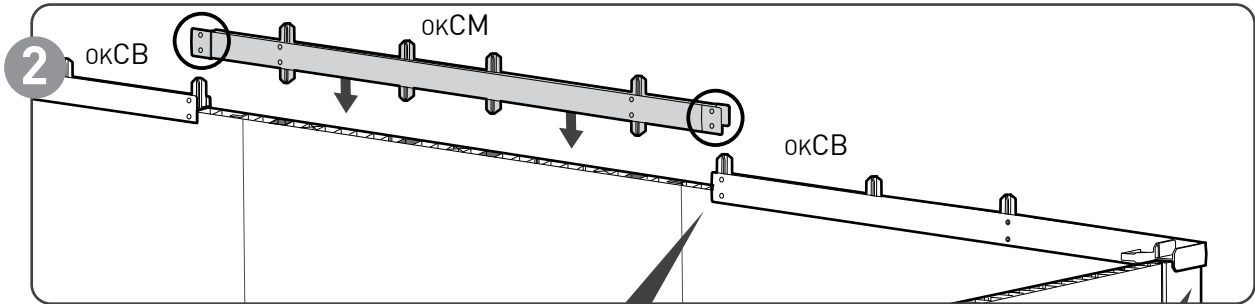
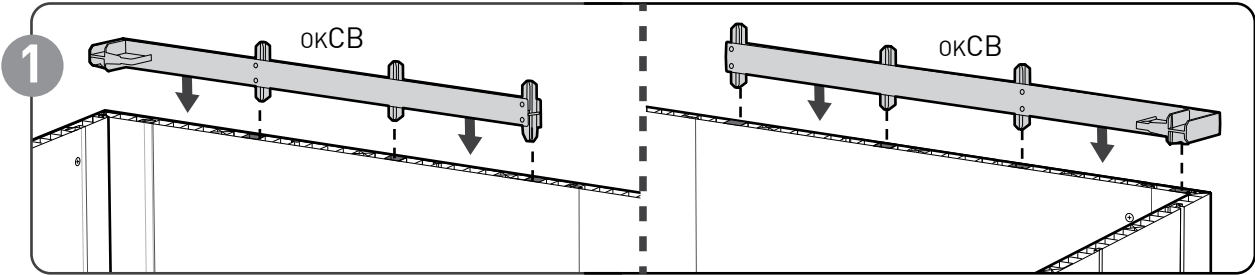

37



sc15 (x6)

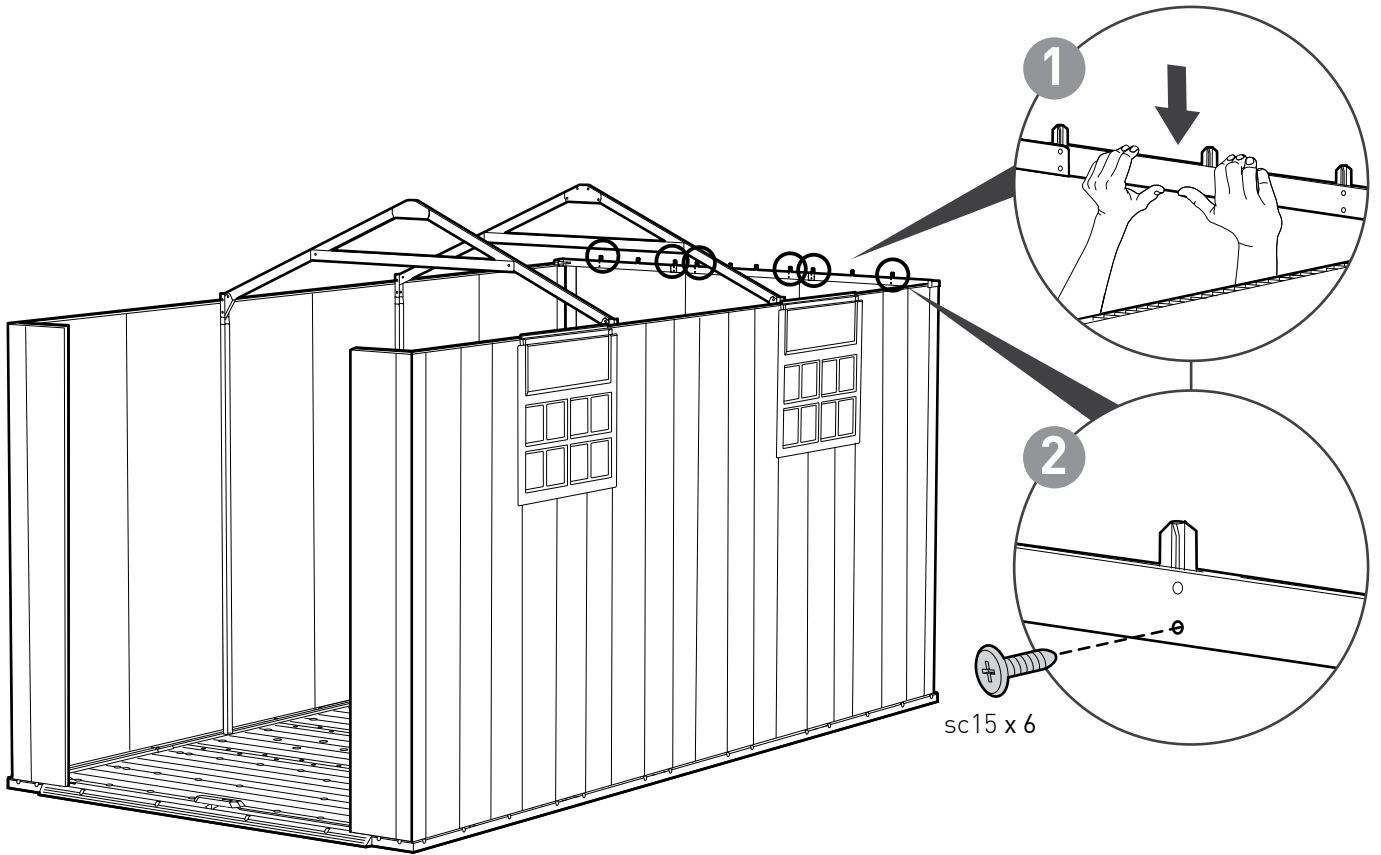

38



NEFM (x1)



s45b (x2)

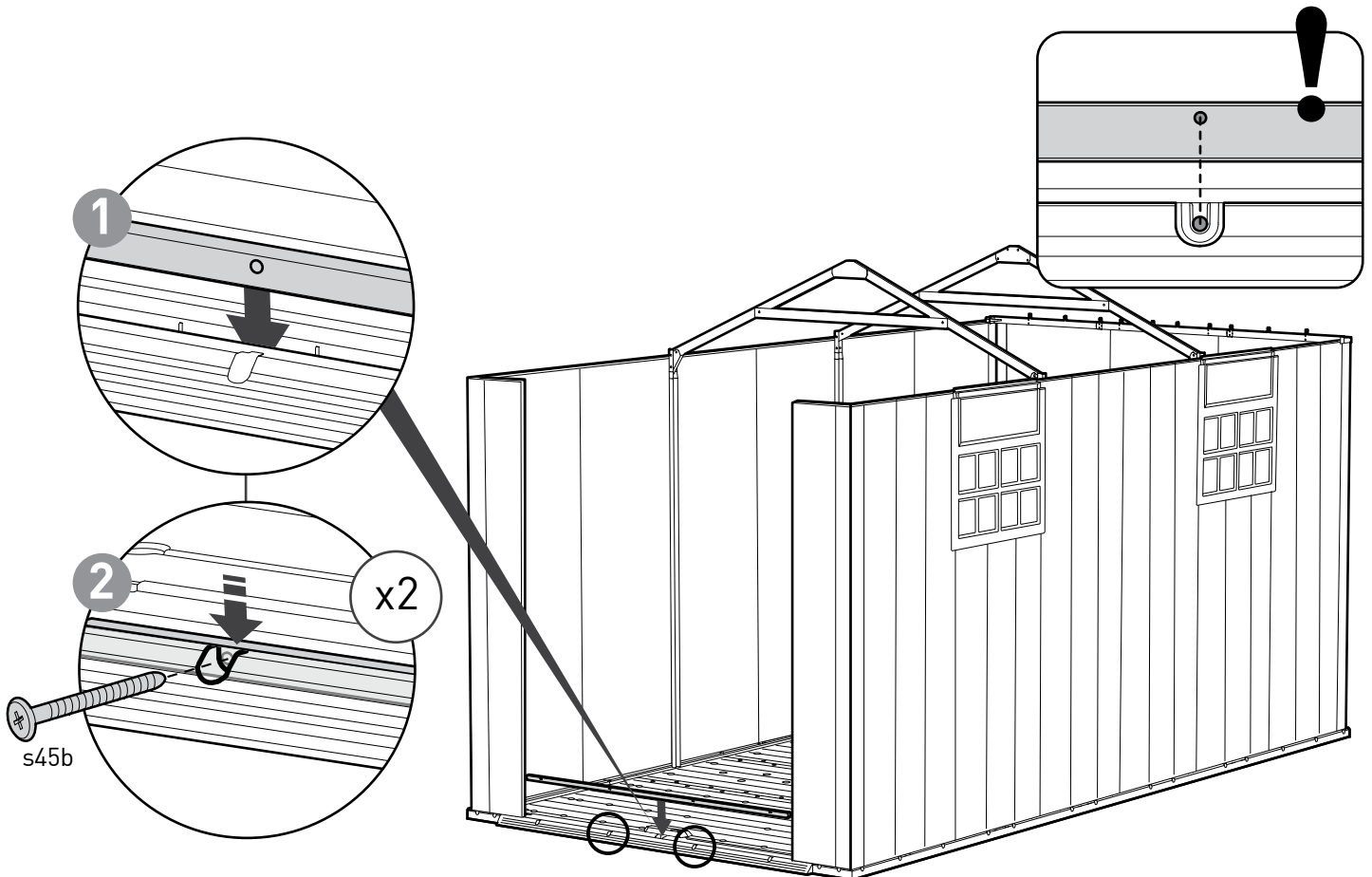

39

 s45b (x2)

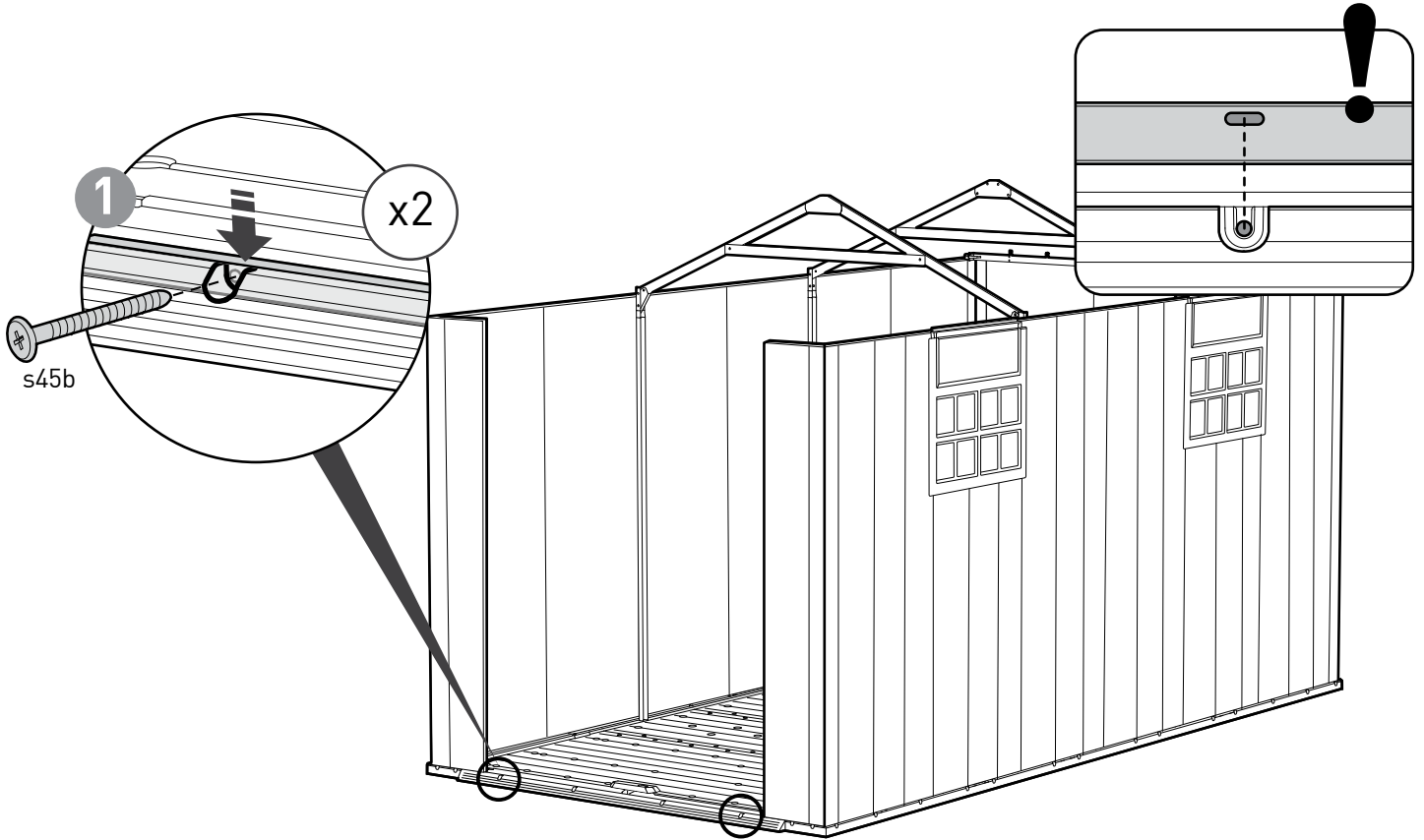

40

 NELR (x2)

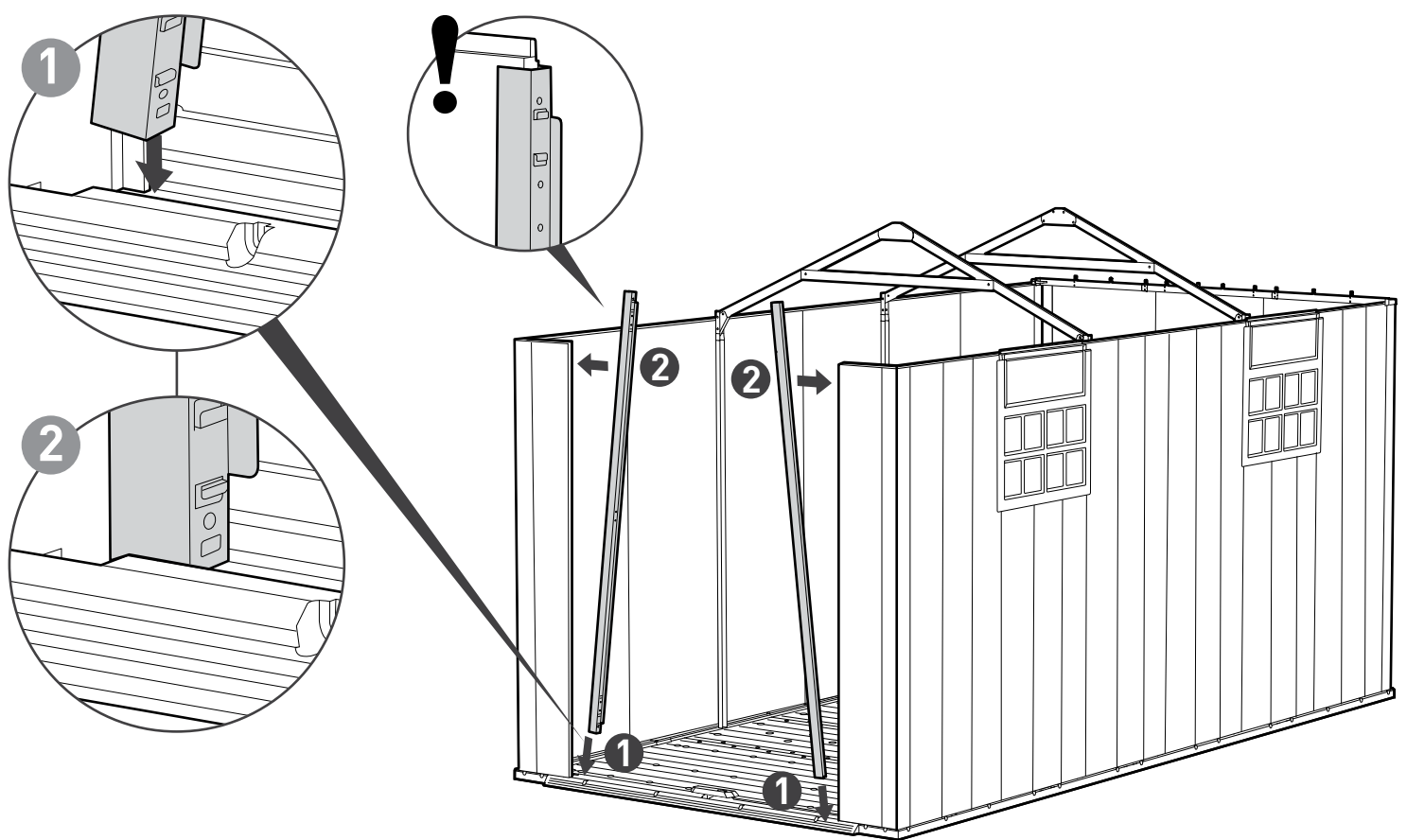

41

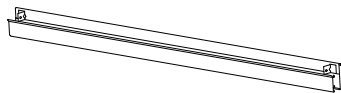

NEUK (x1)



sc7t (x2)

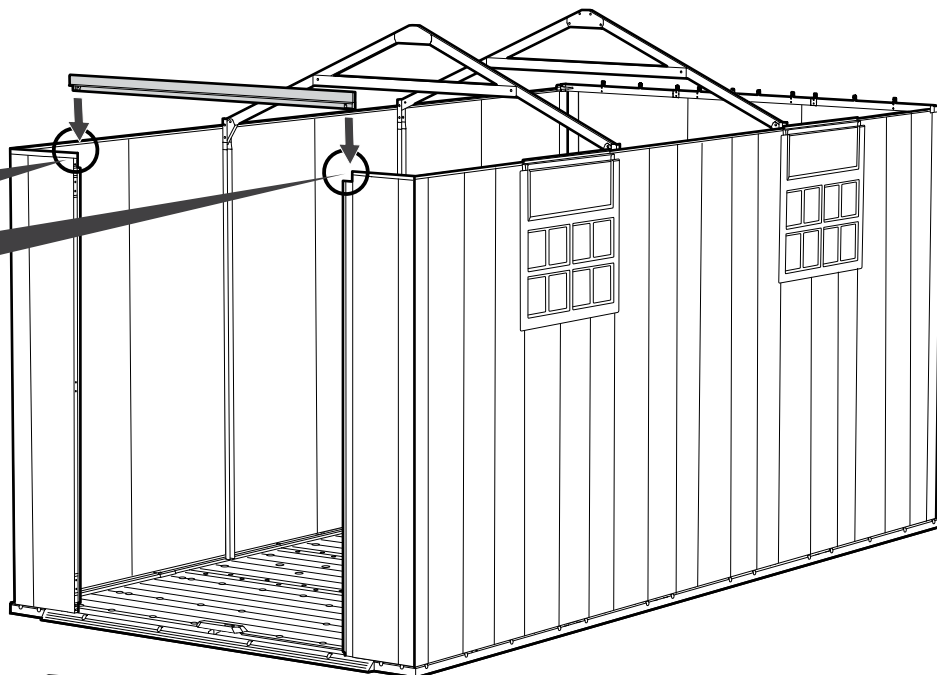
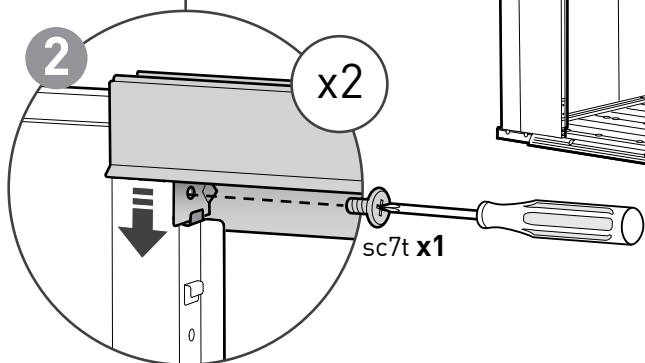
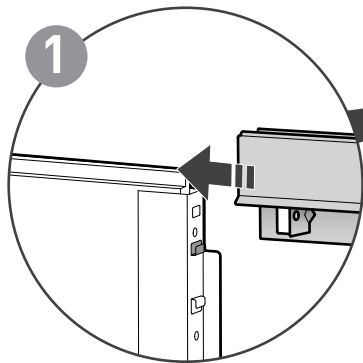

42

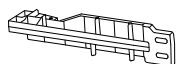

OKCL (x1)

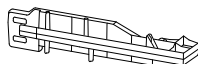

OKCR (x1)

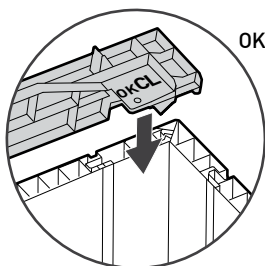

OKCL

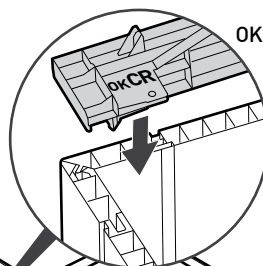

OKCR

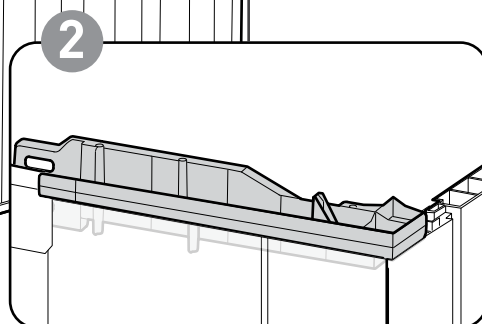
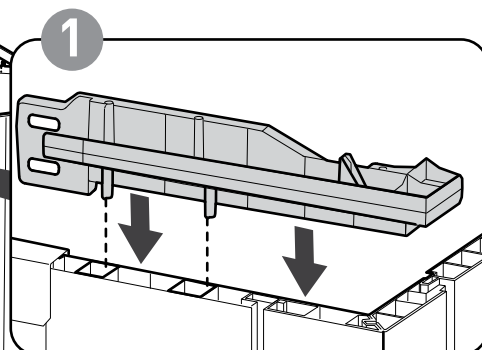
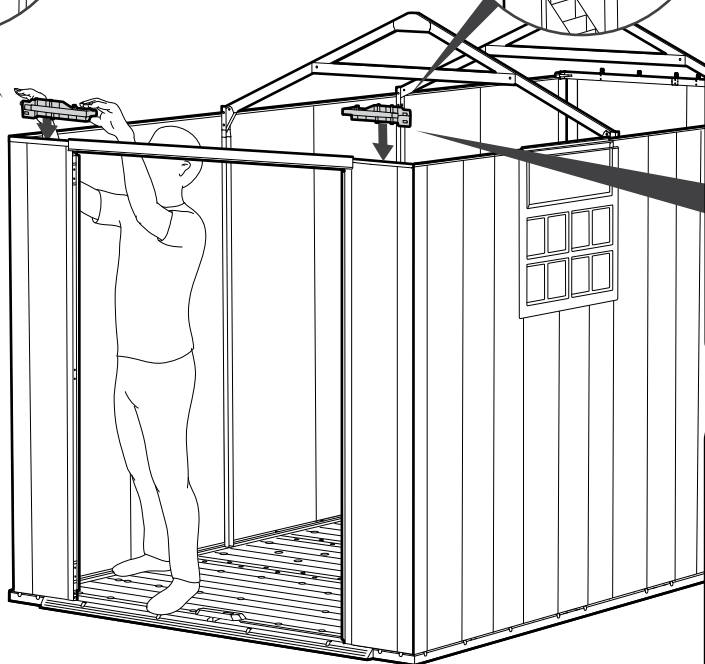



1

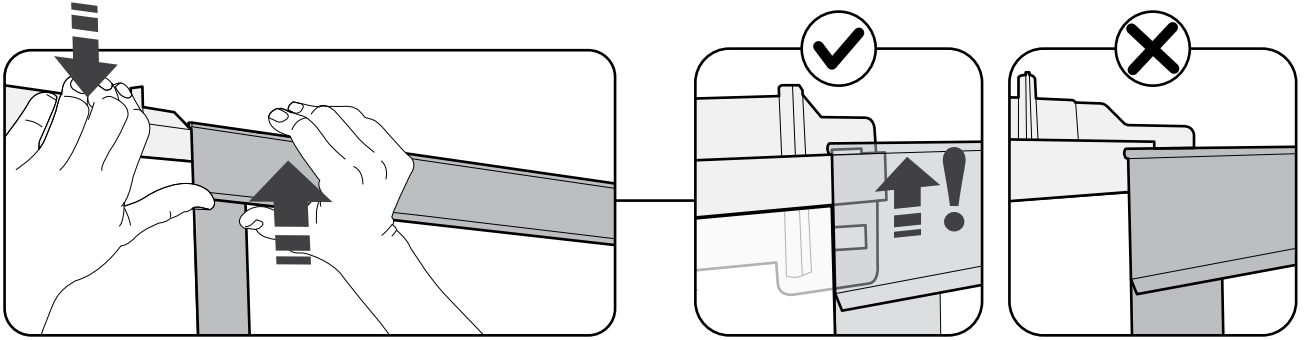

2

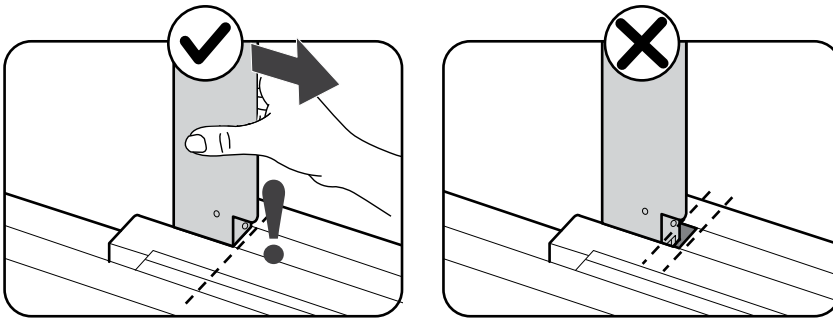

3

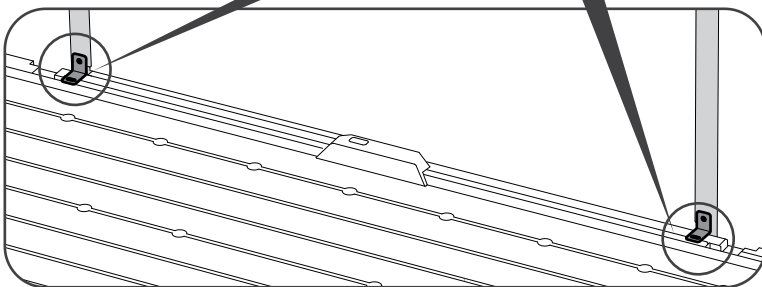
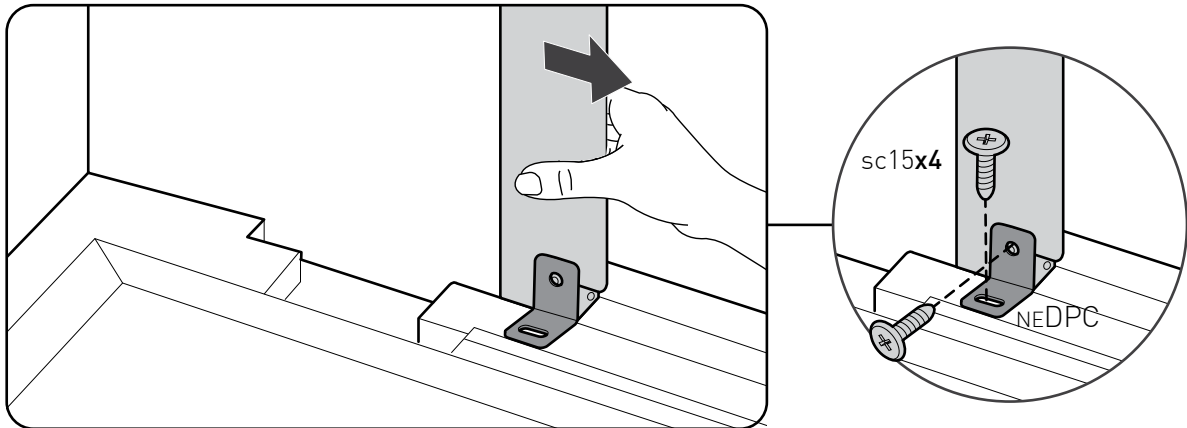

**No pre-drilled holes | Pas de trous pré-perçés | Sin agujeros pretaladrados |
Ohne vorgebohrte Löcher | Geen voorgeboorde gaten | Predisposizione per fori
non present | Sem buracos perforados previamente**

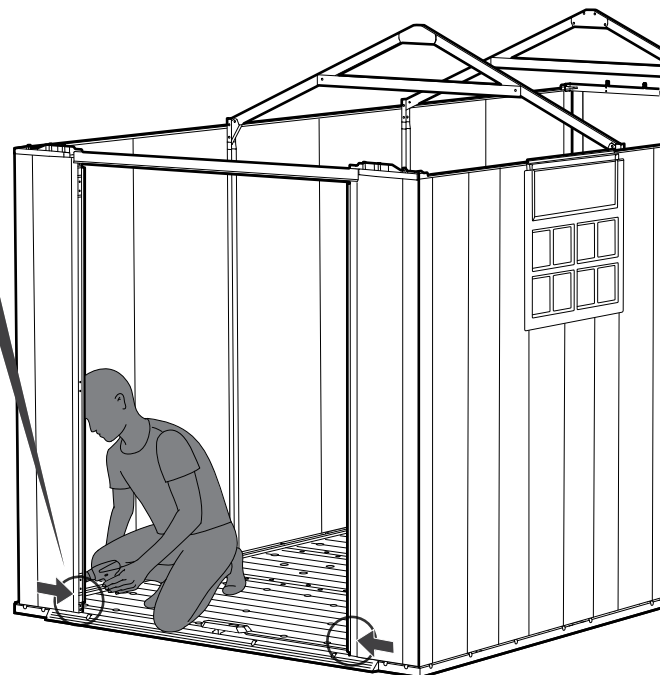

ROOF ASSEMBLY | MONTAGE DU TOIT | ARMADO DEL TECHO | DACHMONTAGE | DAKMONTAGE |
 ASSEMBLAGGIO DEL TETTO | MONTAGEM DO TELHADO

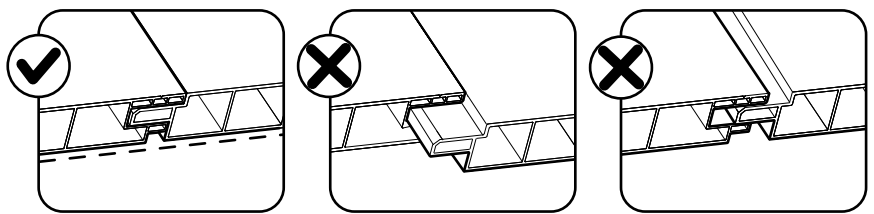
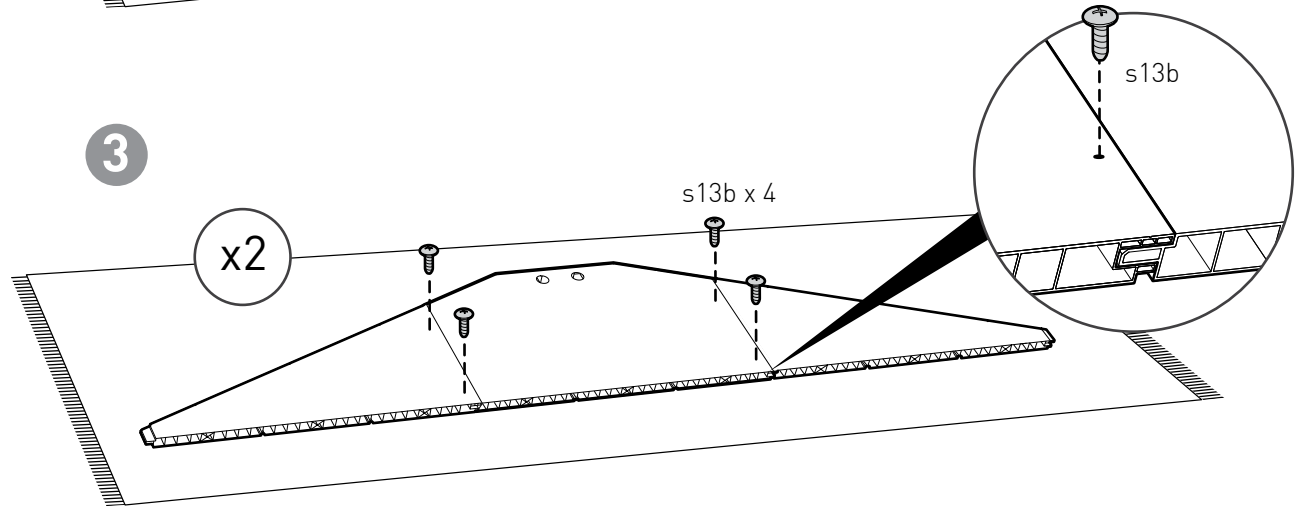
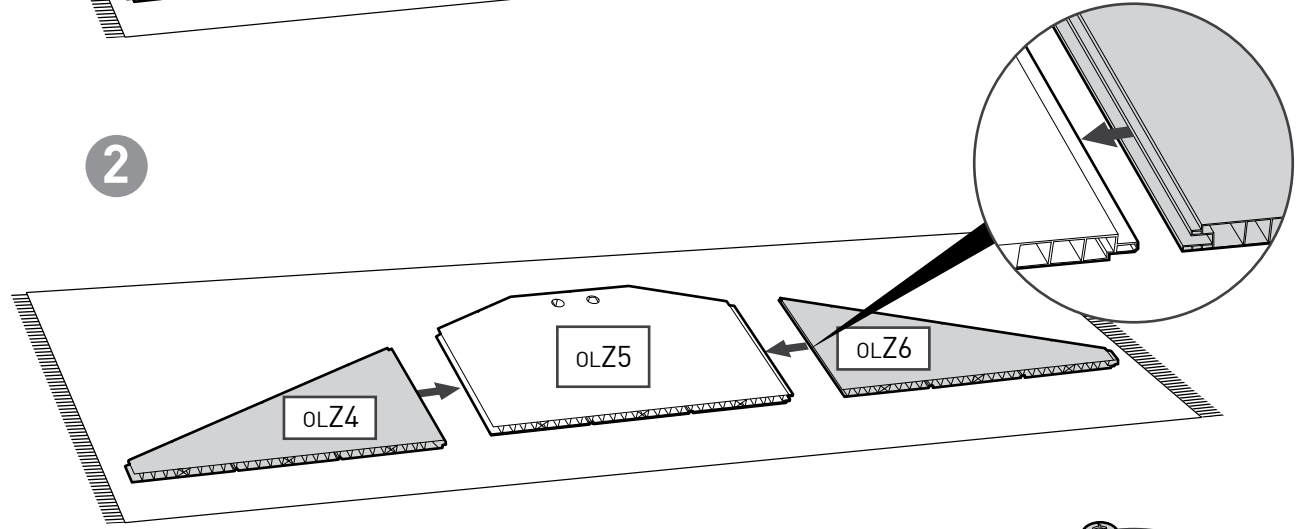
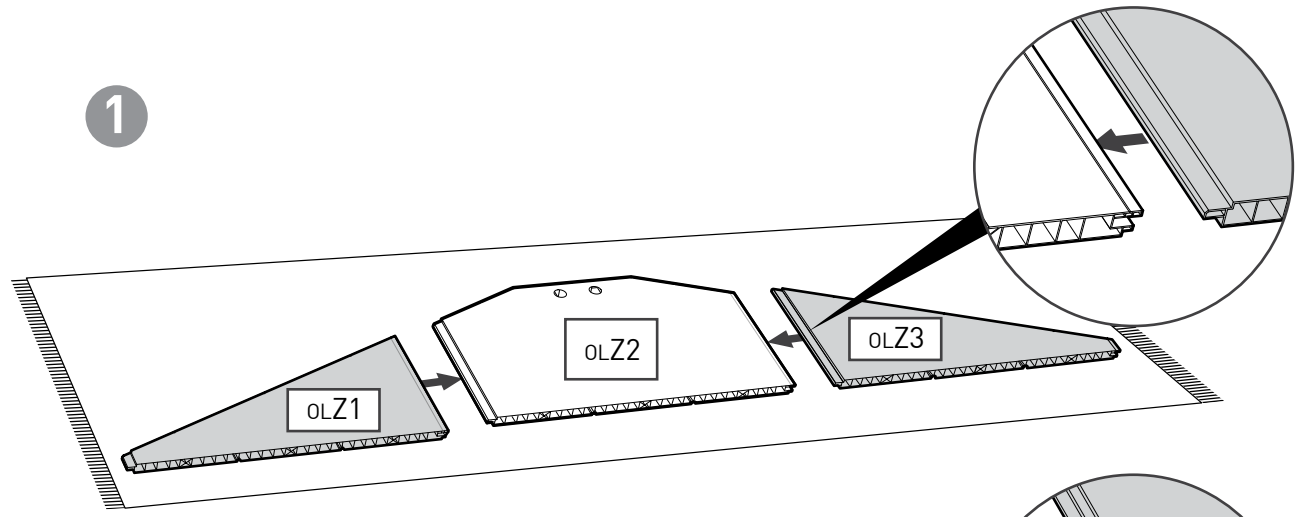
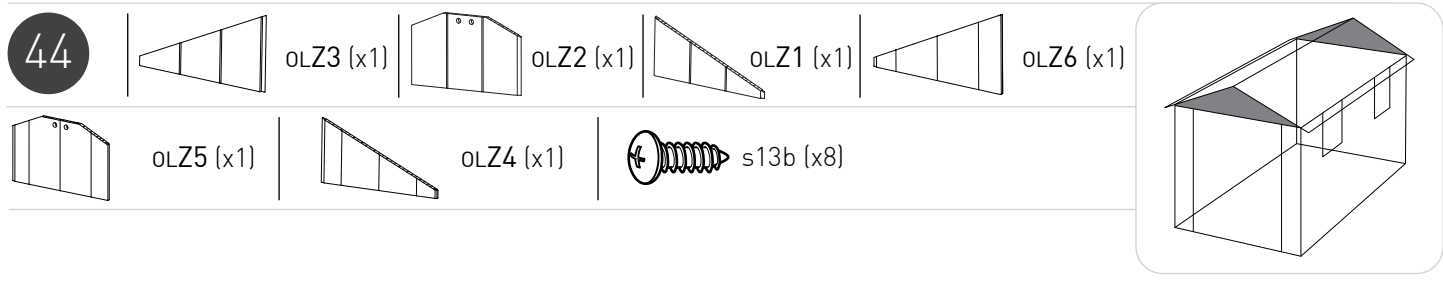

45

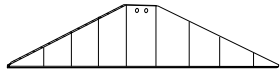

(x2)



moAK (x2)

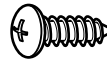

s13b (x2)

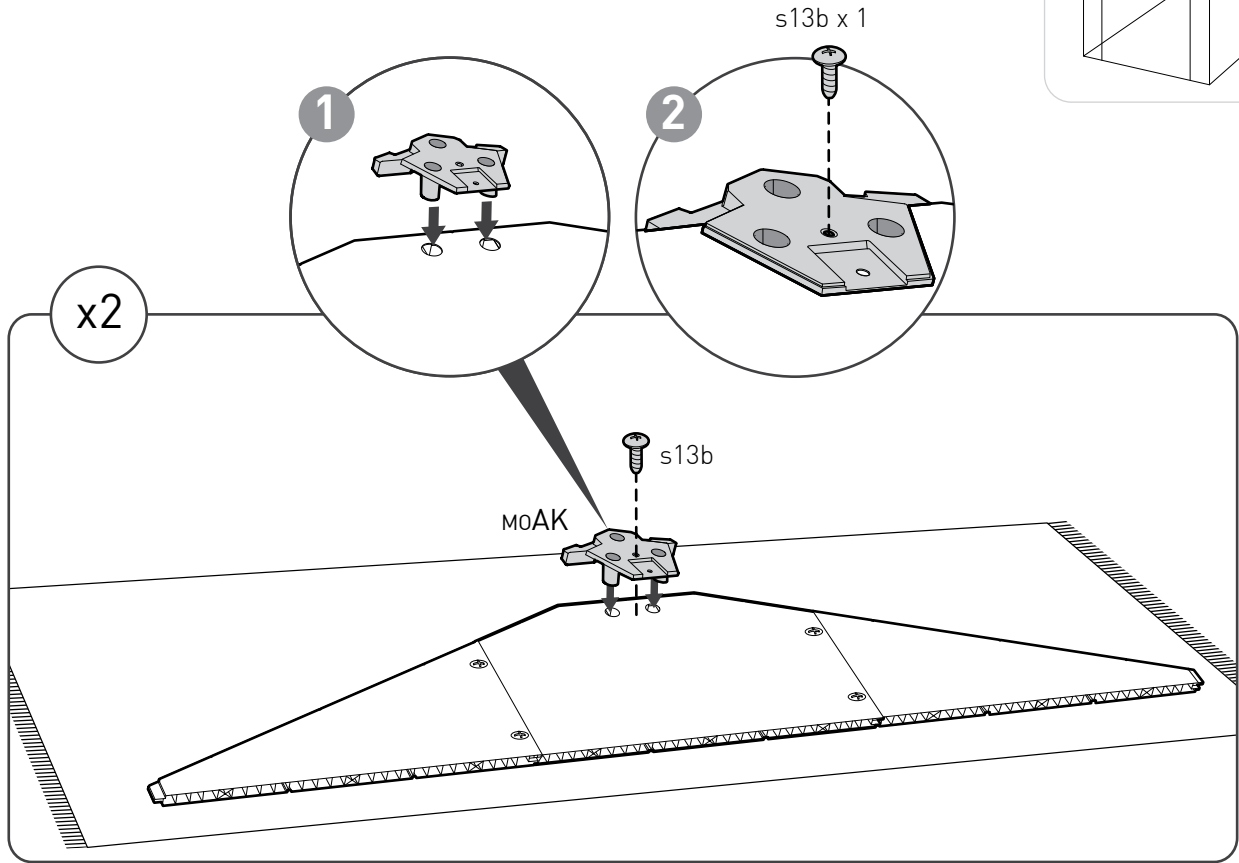
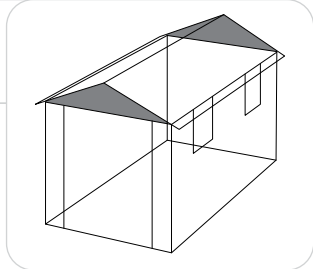

46

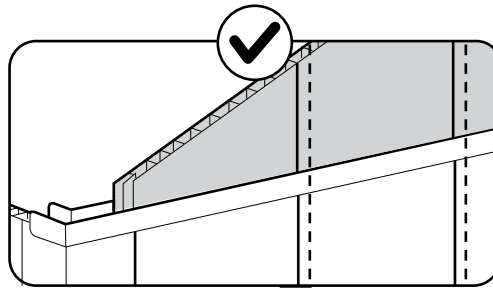
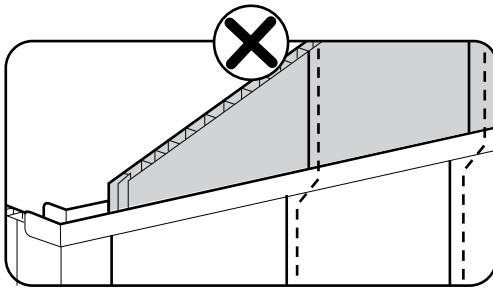
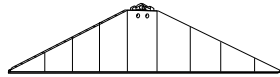

Outside
Extérieure
Exterior
Außenseite
Buitenkant
Esterno
Exterior

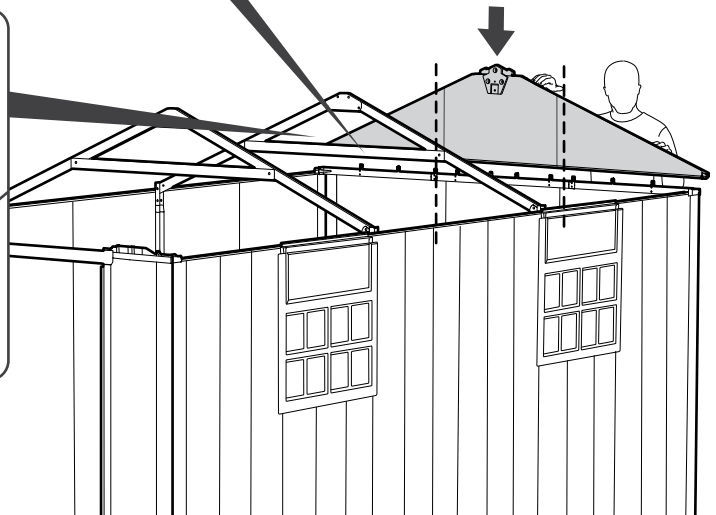
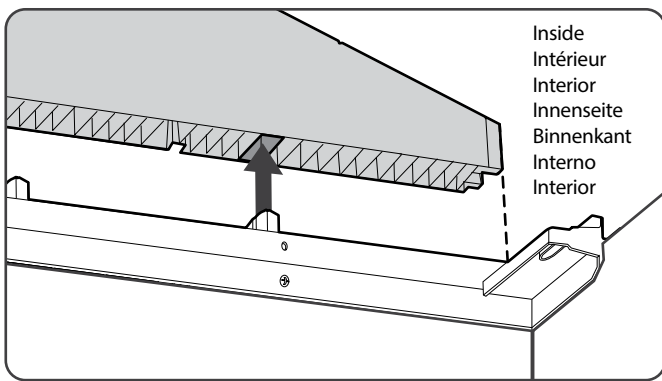
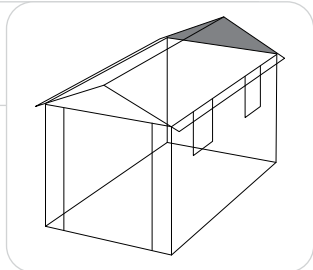

47



KP (x2)

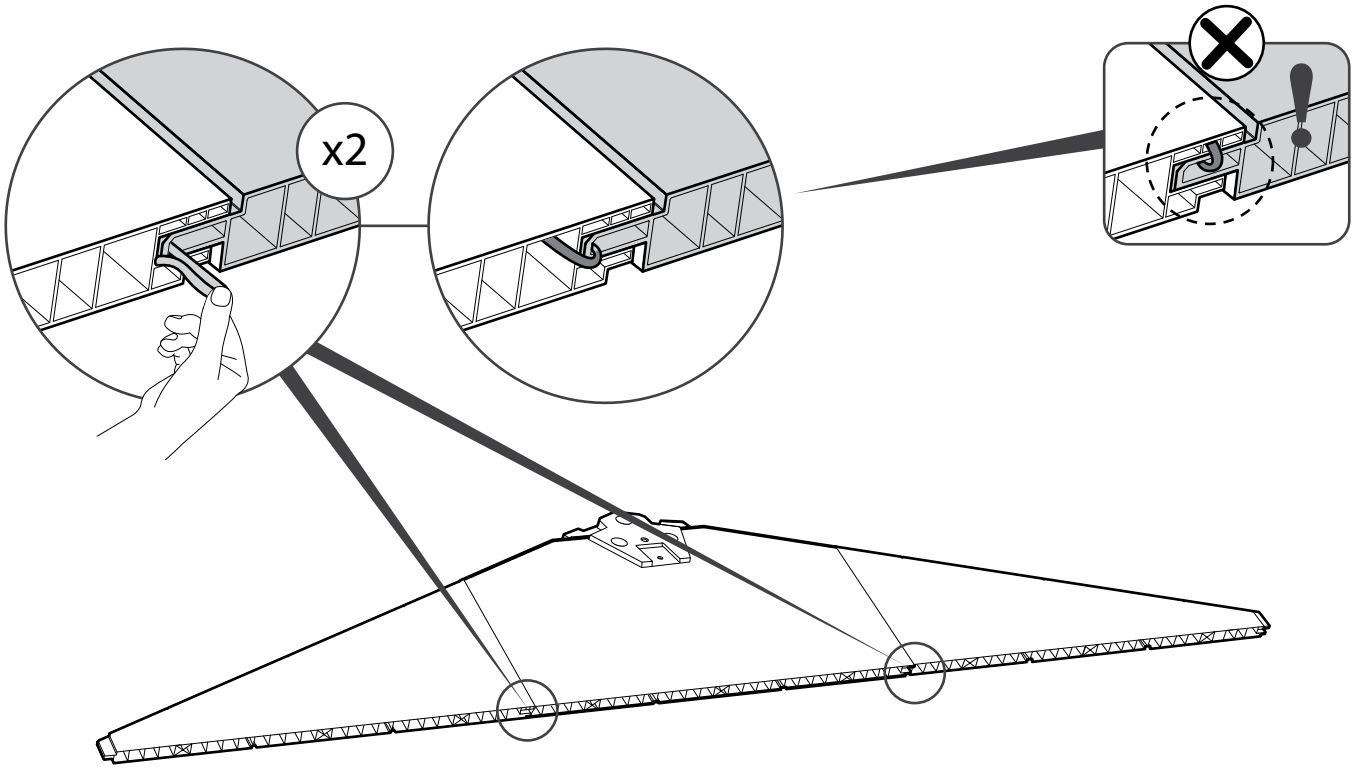

48

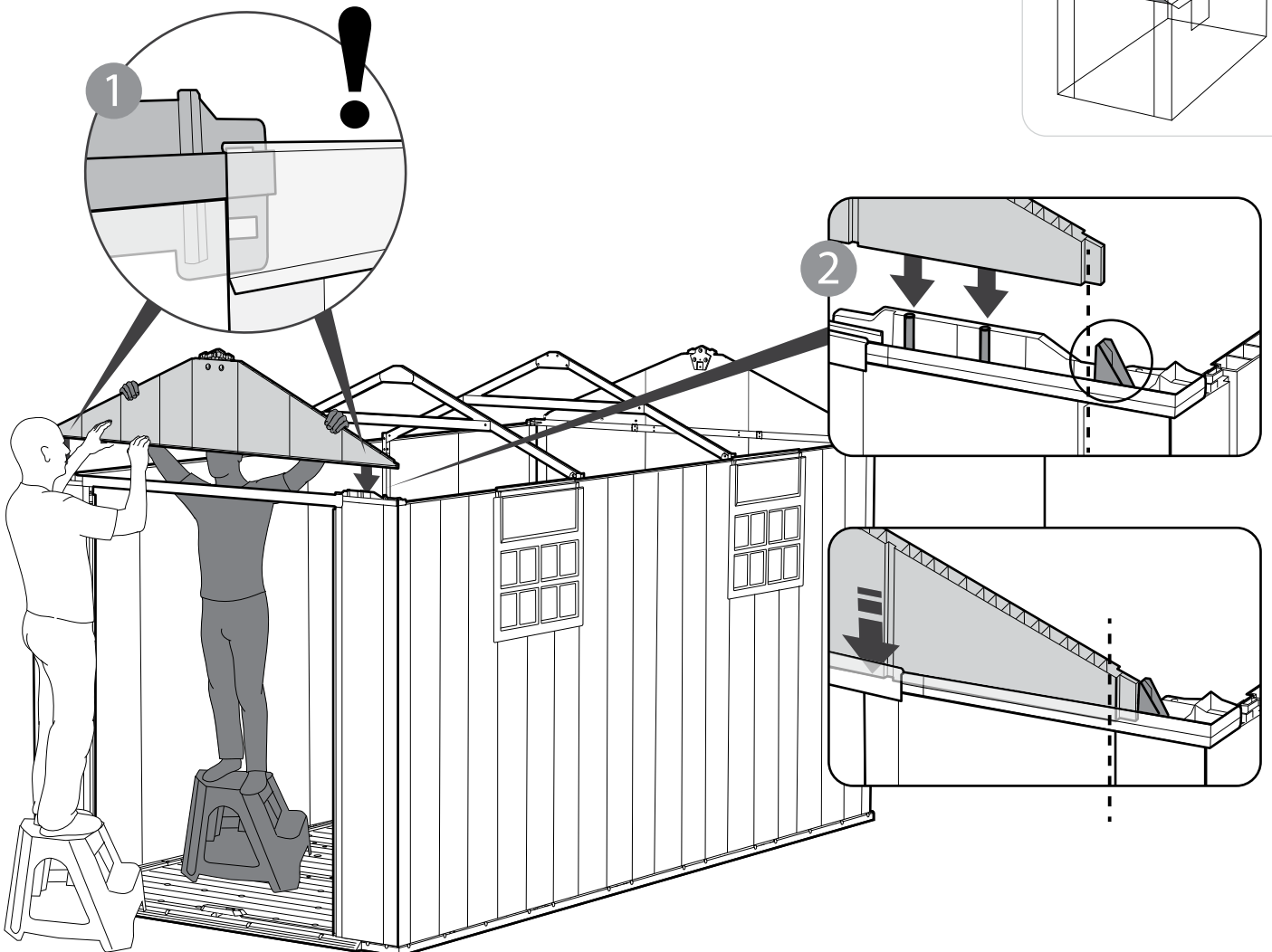
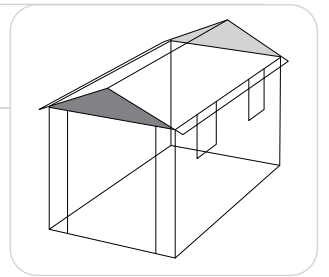
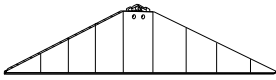

49

 s13b (x8)

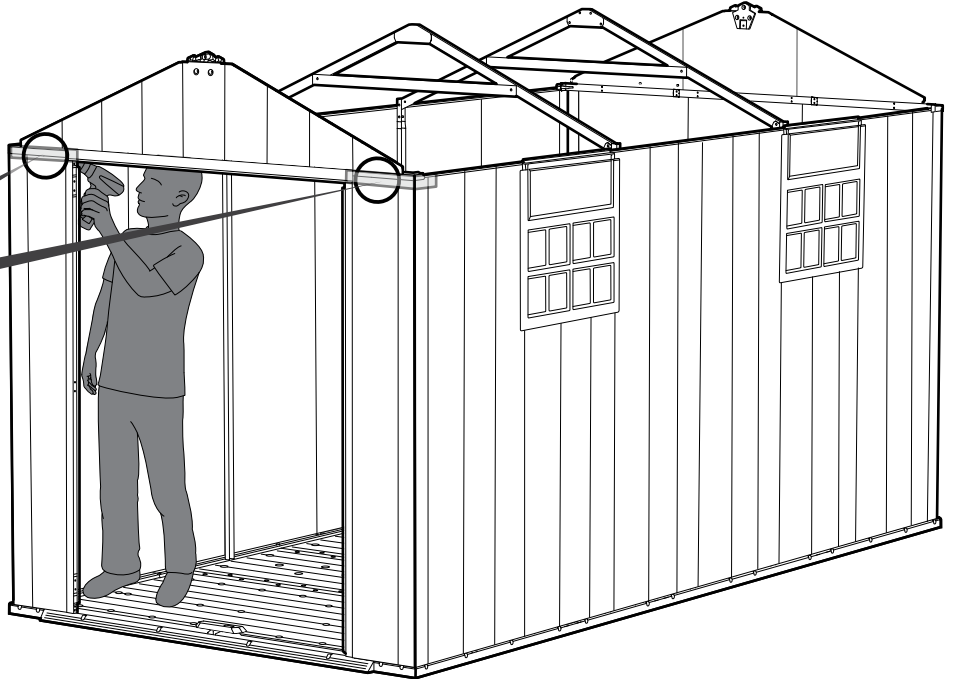
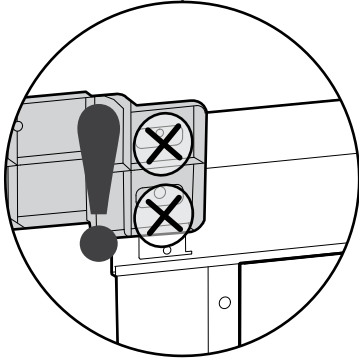
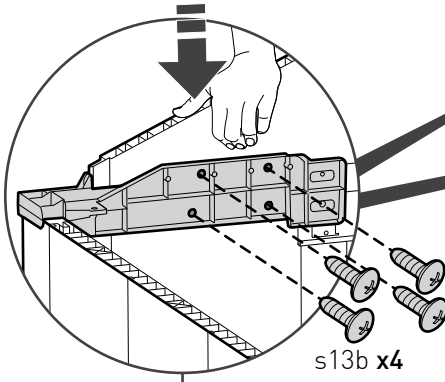

50



 moMB (x1)

 sc15 (x6)

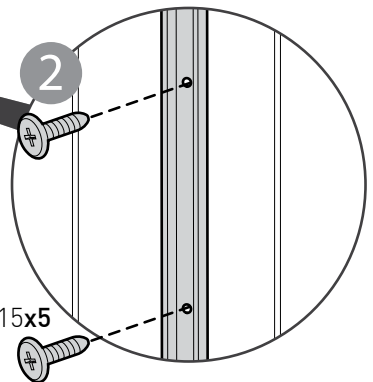
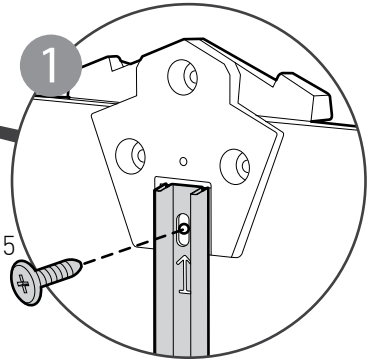
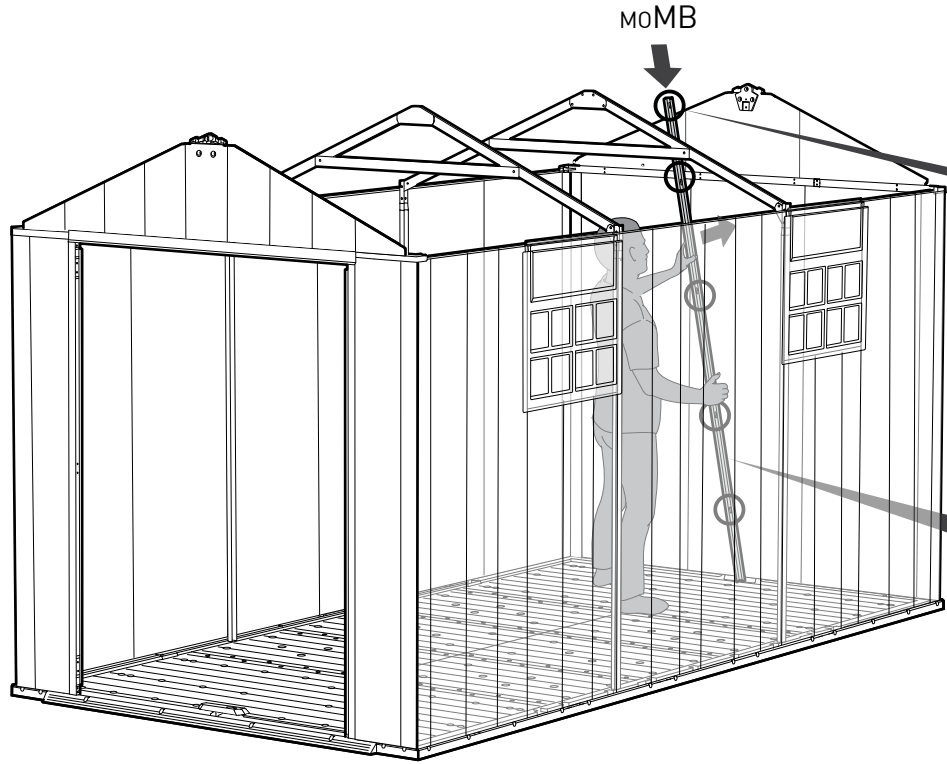
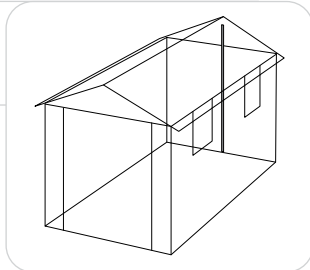

51



MOFTD (x2)

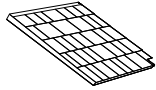

MOFTU (x2)

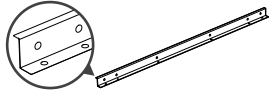

MOFM7 (x4)



sc15 (x20)

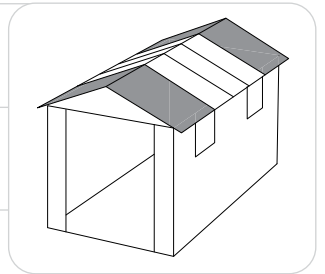

1

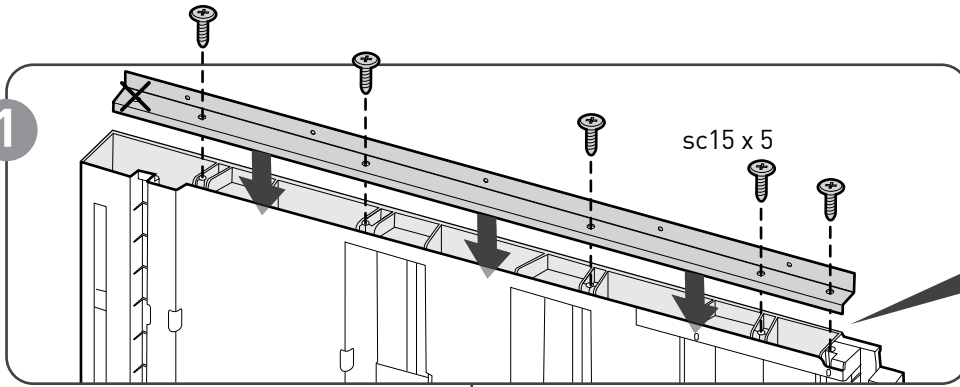

2

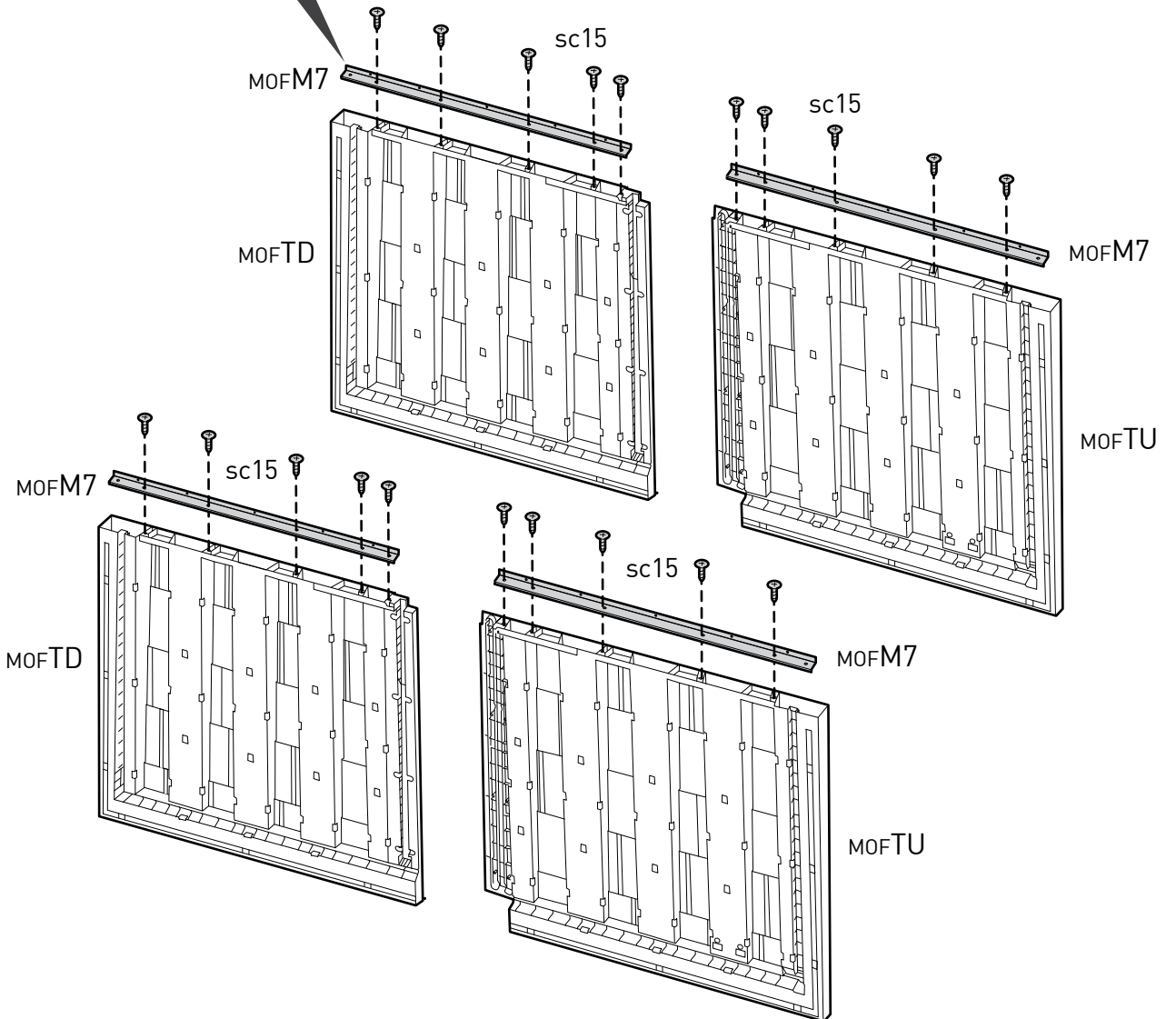
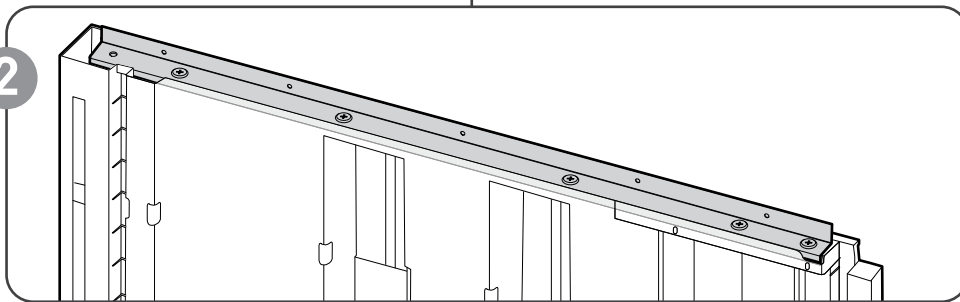

52



MOFT9 (x6)

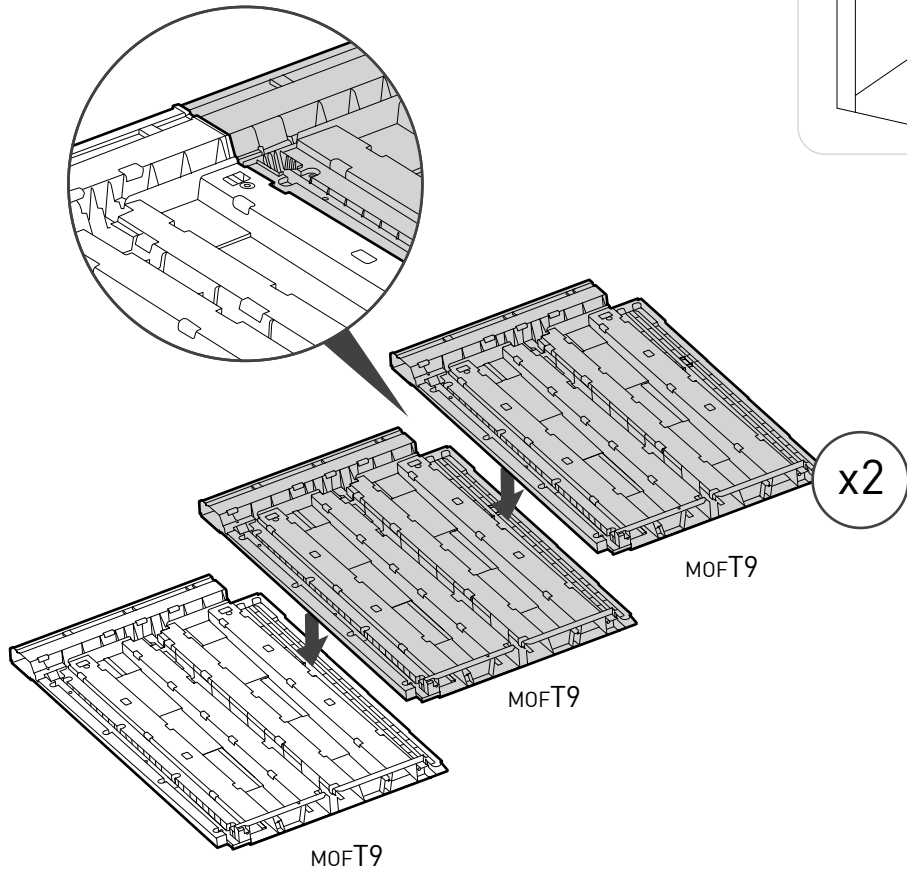
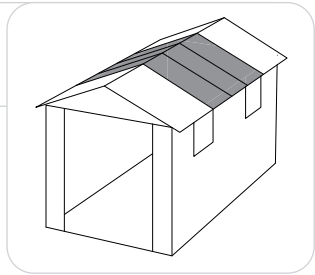

53



(x2)

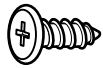

sc15 (x32)

