

KombiSIGN 70 / Terminal Element

Terminal element RM 12-230VAC/DC BK

Part No.:	840.080.00
Series:	KombiSIGN 70

**MECHANICAL DATA**

Height	44 mm
Diameter	70 mm
Materials	PA-GF PC/ABS
Housing colour	Black
Protection category	IP54
Connection	Screw terminals
cross-sectional area maximum	1,50mm ² / 16AWG
Cable entry	Through hole
Cable entry maximum	d = 11 mm
Type of fixing	Tube mounting
Working temperature minimum	-20°C
Working temperature maximum	+50°C
Weight with packaging	116 g
Product weight	98 g

ELECTRICAL DATA

Operating voltage	12-230V
Operating voltage type	AC/DC
Protection class	Protection class 1
Pollution degree	3
Overtoltage category	II
Isolation voltage	Ui = 250V; Uimp = 2.500V

APPROVAL DATA

Conforms with CE	Yes
WEEE	Yes
Conforms with ATEX-directive	No
Conforms with CCC	No
Conforms with UL	cULus
UL Type Rating	Type 12
Conforms with FCC	No
Conforms with IC	No
EAC certificate available	Yes
Conforms with UKCA (Importer)	Yes (WERMA (UK) Ltd.)
Conforms with CMIM	No
Conforms with AS-I	No
ICAO Certification	No
Conforms with DNV	No



For additional installation and mounting information, refer to the appropriate user guide at www.werma.com. This printed copy is for information only and is subject to alteration.

KombiSIGN 70 / Terminal Element

Terminal element RM 12-230VAC/DC BK

Conforms with RoHS CN	No
Conforms with VdS	No

DRAWING

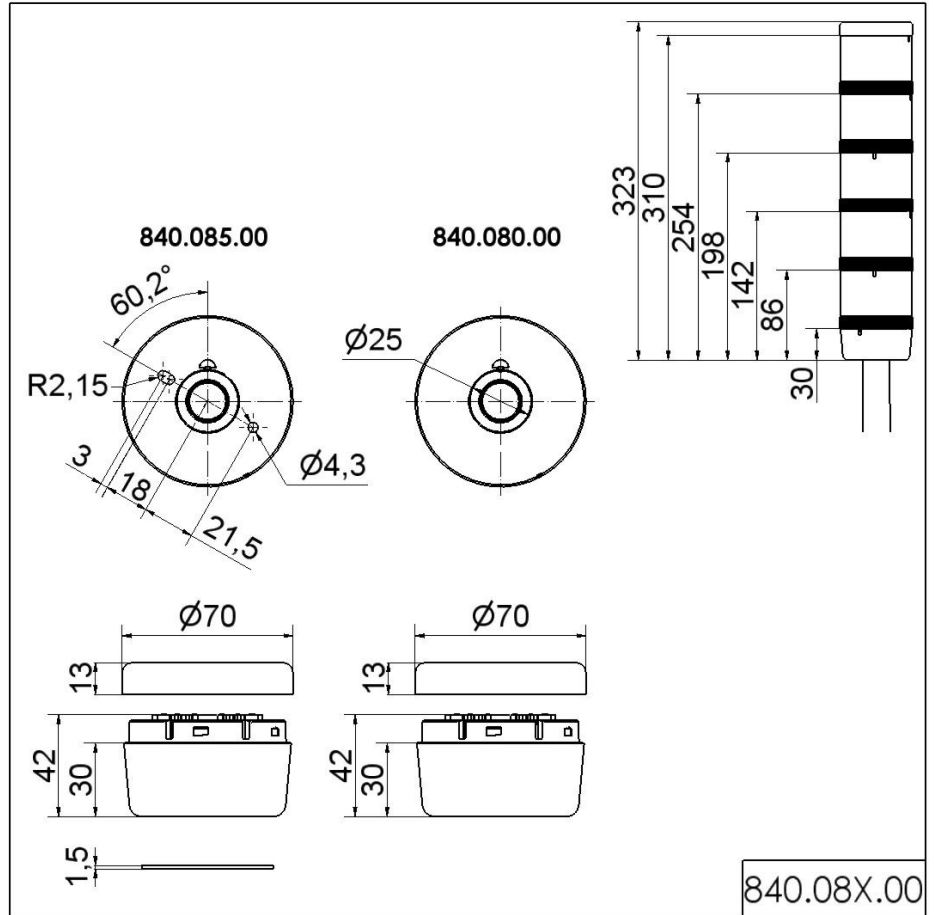

! For additional installation and mounting information, refer to the appropriate user guide at www.werma.com. This printed copy is for information only and is subject to alteration.