

# OGP201

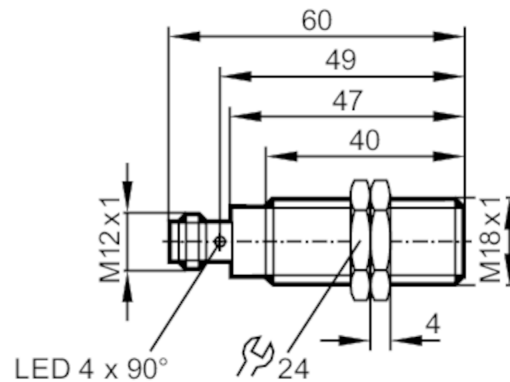

## Retro-reflective sensor

OGP-HPKG/US100



Application	
Function principle	Retro-reflective sensor
Electrical data	
Operating voltage [V]	10...36 DC
Current consumption [mA]	15
Protection class	II
Reverse polarity protection	yes
Type of light	red light
Wave length [nm]	624
Outputs	
Electrical design	PNP
Output function	light-on mode
Max. voltage drop switching output DC [V]	2.5
Permanent current rating of switching output DC [mA]	200
Switching frequency DC [Hz]	1000
Short-circuit protection	yes
Type of short-circuit protection	pulsed
Overload protection	yes
Detection zone	
Range referred to prismatic reflector [m]	0.03...4; (Prismatic reflector Ø 80 E20005)
Range adjustable	no
Max. light spot diameter [mm]	160
Light spot dimensions refer to	at maximum range
Polarisation filter available	yes
Operating conditions	
Ambient temperature [°C]	-25...60
Protection	IP 67

# OGP201



## Retro-reflective sensor

OGP-HPKG/US100

### Tests / approvals

EMC		EN 60947-5-2	
MTTF	[years]		500

### Mechanical data

Weight	[g]		50.4
Housing			threaded type
Dimensions	[mm]		M18 x 1 / L = 60
Thread designation			M18 x 1
Materials			housing: stainless steel (1.4404 / 316L)
Lens material			PMMA

### Displays / operating elements

Display		switching status	1 x LED, yellow
---------	--	------------------	-----------------

### Accessories

Accessories (supplied)			lock nuts: 2 x
------------------------	--	--	----------------

### Remarks

Remarks			operating voltage "supply class 2" according to cULus
Pack quantity			1 pcs.

### Electrical connection

Connector: 1 x M12



### Connection

