

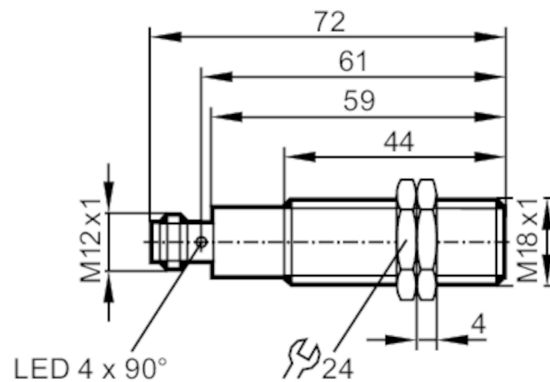

## Diffuse reflection sensor with background suppression

OGH-HPKG/US100



transmitter in lower lens  
receiver in upper lens



Application	
Function principle	Diffuse reflection sensor
Electrical data	
Operating voltage [V]	10...36 DC
Current consumption [mA]	25
Protection class	II
Reverse polarity protection	yes
Type of light	red light
Wave length [nm]	624
Outputs	
Electrical design	PNP
Output function	light-on mode
Max. voltage drop switching output DC [V]	2.5
Permanent current rating of switching output DC [mA]	200
Switching frequency DC [Hz]	1000
Short-circuit protection	yes
Type of short-circuit protection	pulsed
Overload protection	yes
Detection zone	
Range [mm]	< 100; (white paper 200 x 200 mm 90 % remission)
Range adjustable	no
Max. light spot diameter [mm]	9
Light spot dimensions refer to	Range
Background suppression available	yes



## Diffuse reflection sensor with background suppression

OGH-HPKG/US100

### Operating conditions

Ambient temperature	[°C]	-25...60
Protection		IP 67

### Tests / approvals

EMC		EN 60947-5-2
MTTF	[years]	372

### Mechanical data

Weight	[g]	54.8
Housing		threaded type
Dimensions	[mm]	M18 x 1 / L = 72
Thread designation		M18 x 1
Materials		housing: stainless steel; PA; Sealing: FKM
Lens material		glass

### Displays / operating elements

Display	switching status	1 x LED, yellow
---------	------------------	-----------------

### Accessories

Accessories (supplied)	lock nuts: 2 x
------------------------	----------------

### Remarks

Pack quantity	1 pcs.
---------------	--------

### Electrical connection

Connector: 1 x M12



### Connection

