

OGE201

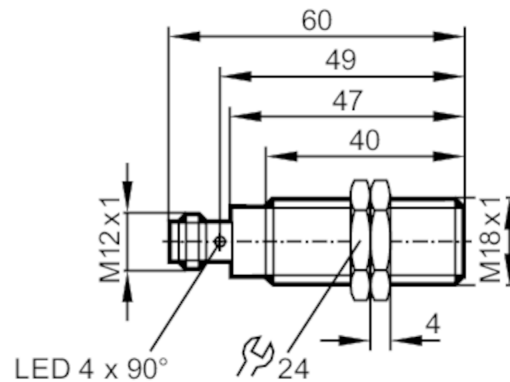

Through-beam sensor receiver

OGE-HPKG/US100



Application	
Function principle	Through-beam sensor
Electrical data	
Operating voltage [V]	10...36 DC
Current consumption [mA]	10
Protection class	II
Reverse polarity protection	yes
Type of light	red light
Wave length [nm]	624
Outputs	
Electrical design	PNP
Output function	light-on mode
Max. voltage drop switching output DC [V]	2.5
Permanent current rating of switching output DC [mA]	200
Switching frequency DC [Hz]	1000
Short-circuit protection	yes
Type of short-circuit protection	pulsed
Overload protection	yes
Detection zone	
Transmitter / receiver	receiver
Range [m]	< 20
Range adjustable	no
Operating conditions	
Ambient temperature [°C]	-25...60
Protection	IP 67



Through-beam sensor receiver

OGE-HPKG/US100

Tests / approvals

EMC		EN 60947-5-2
MTTF	[years]	1067

Mechanical data

Weight	[g]	50
Housing		threaded type
Dimensions	[mm]	M18 x 1 / L = 60
Thread designation		M18 x 1
Materials		housing: stainless steel (1.4404 / 316L)
Lens material		PMMA

Displays / operating elements

Display	switching status	1 x LED, yellow
---------	------------------	-----------------

Accessories

Accessories (supplied)	lock nuts: 2 x
------------------------	----------------

Remarks

Remarks	operating voltage "supply class 2" according to cULus
Pack quantity	1 pcs.

Electrical connection

Connector: 1 x M12



Connection

