

OGH200

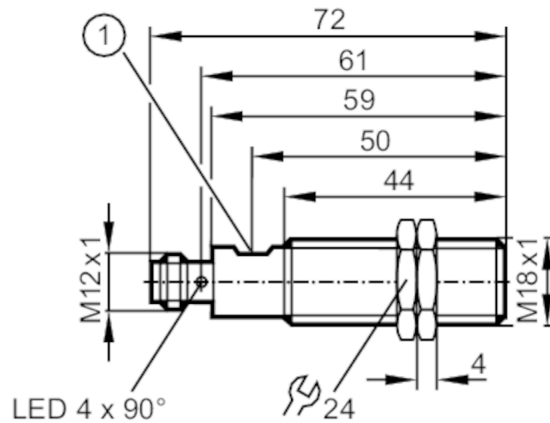

Diffuse reflection sensors with background suppression

OGH-HPKG/US100



1 potentiometer



Product characteristics

Type of light	red light
Housing	Threaded type
Dimensions [mm]	M18 x 1 / L = 72

Application

System	Background suppression
Function principle	Diffuse reflection sensor

Electrical data

Operating voltage [V]	10...36 DC
Current consumption [mA]	25
Protection class	II
Reverse polarity protection	yes
Type of light	red light
Wave length [nm]	624

Outputs

Electrical design	PNP
Output function	light-on mode
Max. voltage drop switching output DC [V]	2.5
Permanent current rating of switching output DC [mA]	200
Switching frequency DC [Hz]	1000
Short-circuit protection	yes
Type of short-circuit protection	yes (non-latching)
Overload protection	yes

OGH200



Diffuse reflection sensors with background suppression

OGH-HPKG/US100

Monitoring range		
Range	[mm]	15...250; (white paper 200 x 200 mm 90 % remission)
Range on white object (90 % remission)	[mm]	15...250
Range on grey object (18 % remission)	[mm]	15...230
Range on black object (6 % remission)	[mm]	15...160
Range adjustable		yes
Max. light spot diameter	[mm]	21
Light spot dimensions refer to		at maximum range
Background suppression available		yes

Operating conditions		
Ambient temperature	[°C]	-25...60
Protection		IP 65

Tests / approvals		
EMC		EN 60947-5-2
MTTF	[years]	339

Mechanical data		
Weight	[g]	53.2
Housing		Threaded type
Dimensions	[mm]	M18 x 1 / L = 72
Thread designation		M18 x 1
Material		housing: stainless steel; operator interface: TPE
Lens material		PMMA

Displays / operating elements		
Display	Switching status	1 x LED, yellow
Operating elements		potentiometer

Accessories		
Items supplied		lock nuts: 2 x

Remarks		
Remarks		cULus - Class 2 source required
Pack quantity		1 pcs.

Electrical connection

Connector: 1 x M12





Diffuse reflection sensors with background suppression

OGH-HPKG/US100

Connection



Diagrams and graphs

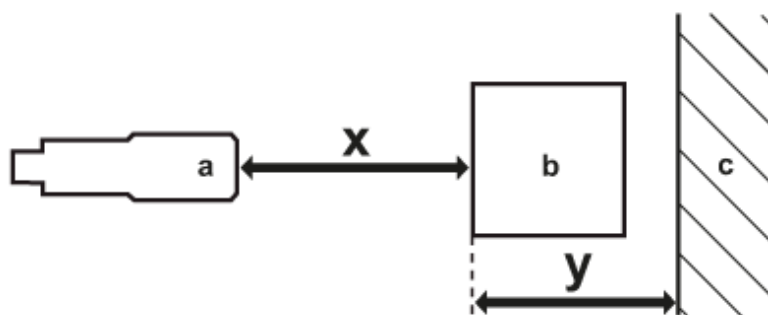

- a: sensor
- b: object
- c: background
- x: distance sensor/object [mm]
- y: min. distance object/background [mm]



Diffuse reflection sensors with background suppression

OGH-HPKG/US100

Background suppression chart

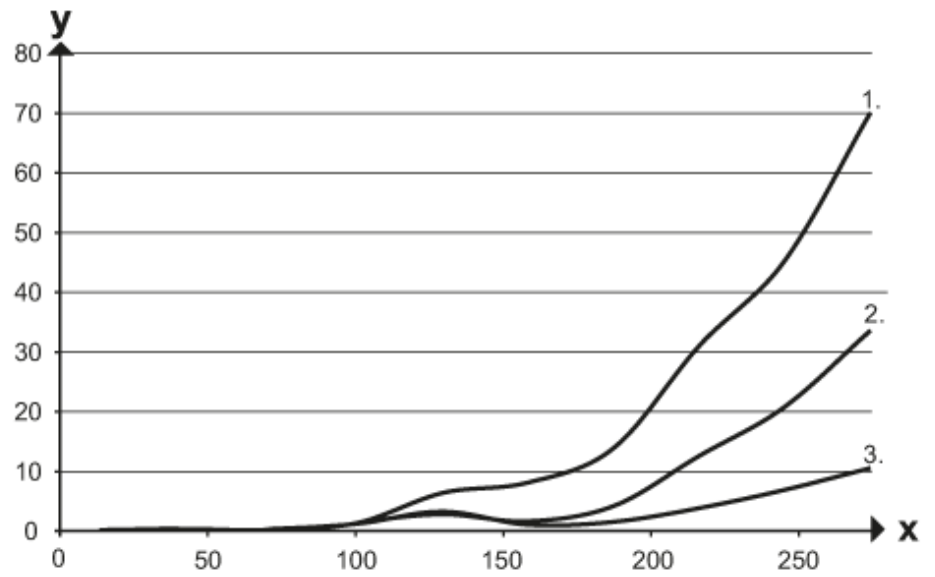

x: distance sensor/object [mm]

y: min. distance object/background [mm]

1 = object black (6 % remission) , background (white 90 % remission)

2 = object grey (18 % remission) , background (white 90 % remission)

3 = object white (90 % remission) , background (white 90 % remission)