

V FAQ

Q: Doesn't dry like it's supposed to and my epoxy after 2 hours was still tacky and sticky.

A: It is nothing about the machine. Make sure the ratio of AB resin is proportion in volume or change to use brand resin.

Q: The machine will turn on, but then shut off.

A: The machine will enter sleep mode when not in use for one minute. Press the power button to reboot. Sleep Mode makes products safer and power-saving.

Q: Can I use UV resin?

A: No, it only works for epoxy resin

Q: Does this help to bubbles?

A: Yes, heating the AB resin with this machine before mixing, which can effectively reduce bubbles.

Q: I use a 2:1 epoxy resin with a longer cure time. Can I use this with that resin?

A: Yes with any 2part epoxy resin just not uv resin

Resiners

Resin Curing Machine Air



Please read the manual carefully before use

PRODUCT CATALOGUE

| | | |
|-----|-----------------------------|---|
| I | Controls | 3 |
| II | Instructions | 4 |
| III | Technology Parameters | 7 |
| IV | Cleaning Tips | 7 |
| V | Notes | 7 |
| VI | FAQ | 8 |

III TECHNOLOGY PARAMETERS

| | |
|-----------------|----------------------|
| Product Name | Resin Curing Machine |
| Product Model | Resiners-Air |
| Rated Voltage | 110V/120V |
| Rated Frequency | 60Hz |
| Rated Power | 160W |
| Dimension | W12"*D8"*H4" |

IV CLEANING TIPS

1. Turn off the power before cleaning.
2. Do not clean the product in water or other liquids. You may use tissues or wipes to clean.
3. If the resin spill out of molds, remove it by hands or tools after the resin fully cured on the surface.

V NOTES

1. It is recommended to place molds on the tray before pouring the resin into the molds. Otherwise, you may spill the resin while lifting molds.
2. Do not dismantle the product.
3. Make sure the input voltage is the same as the product described.
4. Do not place the product near heat or fire, to avoid damage.

I CONTROLS

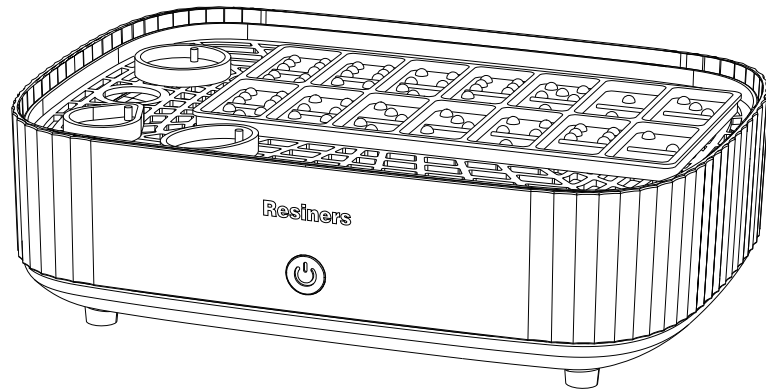

5. For molds thinner than 1/4 inches, the resin may be bendy after 2 hours curing. let the resin stand for 30 to 60 minutes, so the resin can be fully hardened.

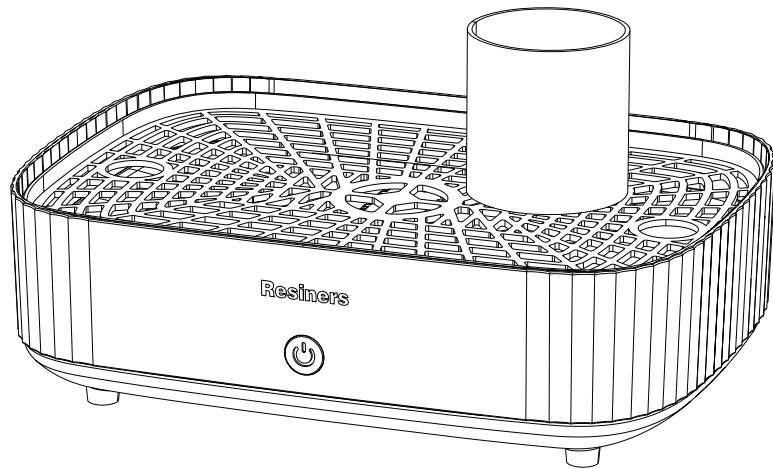

6. For molds thicker than 1.8 inches, it can be used without the lid, but the curing time doubles.

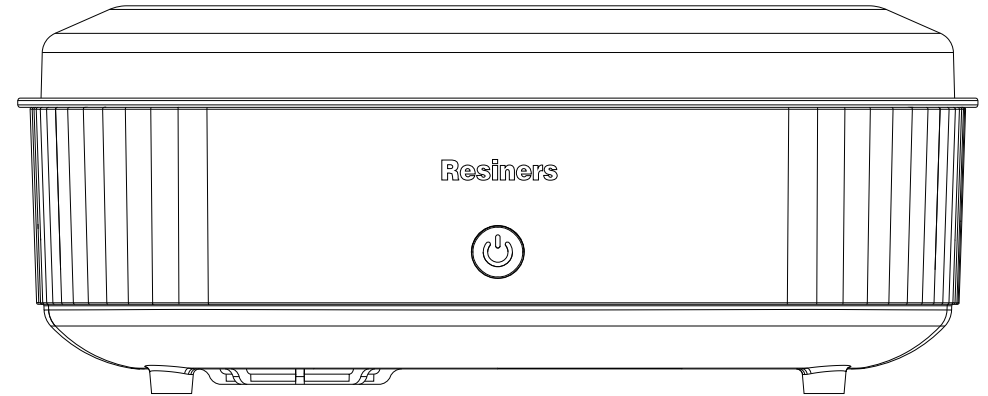

Power Button:

The blue light is on once the power has been connected. Only one click, the machine will be operated for 2 hours while the blue light turns to red. For energy saving, the machine will automatically turn off after two hours working. Click the power button, the machine will wake up again.

Blue Light: Standby Status

Red Light: Operating Process

II INSTRUCTION FOR USE

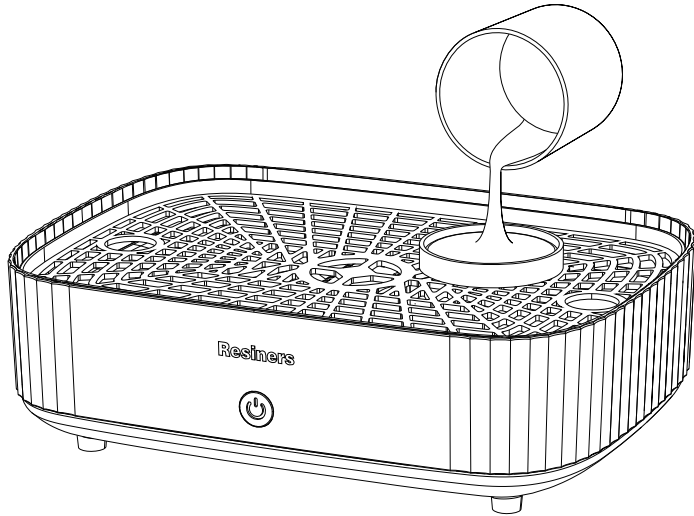

1. It is recommended to place molds on the tray before pouring. Otherwise, you may spill the resin while moving molds.

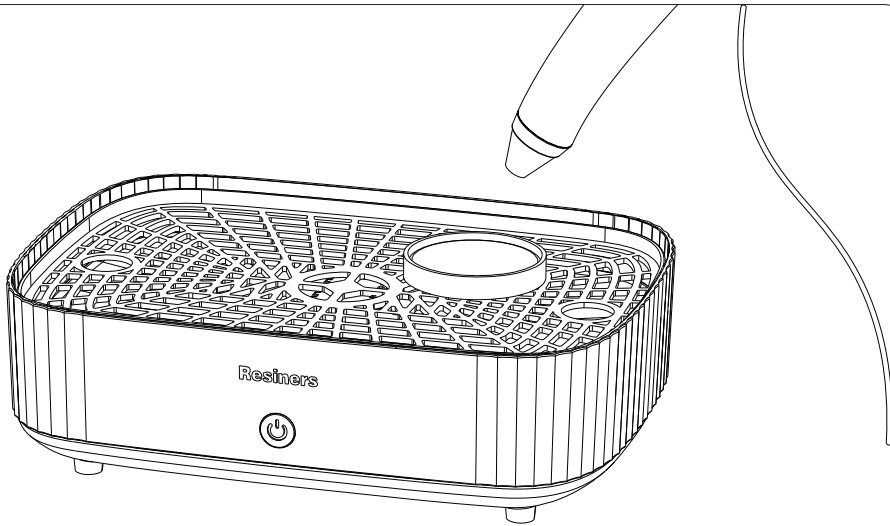

2. Remove bubbles before curing.

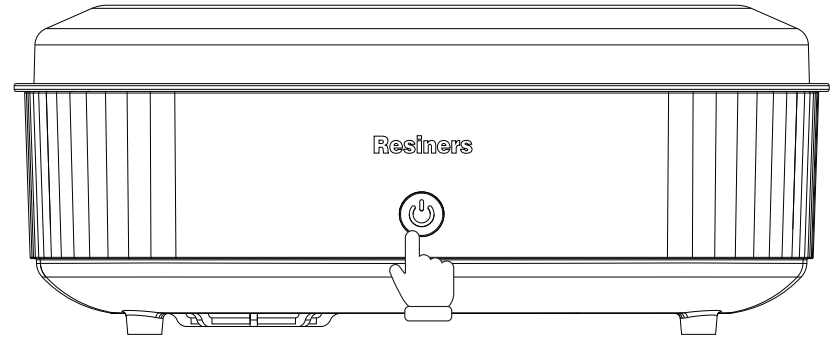

3. Click the power button, the machine operates with red light.



4. Put the lid on, wait 2 hours. Then, your resin has been cured.