

VI FAQ

- Q** Why can't my machine get rid of bubbles or the bubble removing effect not good?
- A**
1. Please check the degassing hole is clean and the silicone cover has plugged.
 2. Please check the vacuum pressure is higher than -92kPa. The air bubbles rising fast only when the vacuum pressure reaches -92kPa.
 3. It is recommended to mix 3oz resin in total every time. Otherwise, the resin may get extremely hot and the air bubbles are stuck inside.
- Q** When the machine starts operating, the value of vacuum doesn't change?
- A**
1. Please check the degassing hole is clean and the silicone cover has plugged.
 2. Please take off the top head, and put it on again.
 3. If the previous steps don't work, please press down the top head when the program starts operating, let go when value starts to rise.
- Q** How many minutes do I need to remove the bubbles completely?
- A** There are many factors that may cause the air bubbles more or less, such as temperature, the quality or amount of resin, the ratio of AB resin, the speed of mixing and etc. In general, 9 minutes is enough to remove bubbles completely for 3oz mixed resin.

V NOTES

1. It takes about 30 seconds to release the pressure after the silicone cover has been unplugged. If wait less than 30 seconds, the top head may be hard to take off or the silicone ring may be pulled off.
2. The container and inner shell deforms slightly during the process of vacuuming, it will resile automatically after the silicone cover unplugged.
3. If the table is smooth, the machine may moving slightly during the process of vacuuming. It is recommended to operate the machine on a silicone mat.
4. It is normal if the machine get hot slightly after used continuously.
5. If there is any other problems, please do not hesitate to contact us. We are dedicated to the satisfaction and success of every customer.

Resiners | AirLess

Bubble Removal Machine

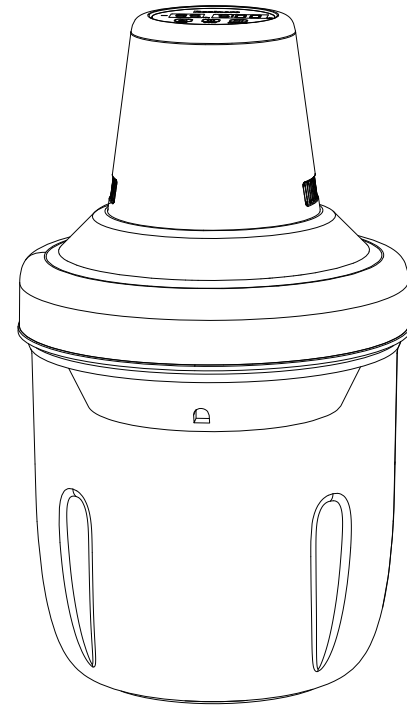

Please read the manual carefully before use

PRODUCT CATALOGUE

I	Controls	3
II	Instructions	4
III	Technology Parameters	7
IV	FAQ	8
V	Notes	8

III TECHNOLOGY PARAMETERS

Product Name	Bubble Removal Machine
Product Model	Resiners-AirLess
Rated Input Voltage	100V ~ 240V
Rated Output Voltage	DC12V
Rated Frequency	50Hz ~ 60Hz
Rated Current	≤1200mA
Air Flow Rate	≥12L/Min
Vacuum Pressure	≥-95kPa
Work Life Time	≥1000Hours
Loaded Noise	≤56dBA@30cm
Operating Temperature	-10 C ~ 50 C
Storage Temperature	10 C ~ 50 C
Operating Humidity	20% ~ 90%RH
Storage Humidity	35% ~ 75%RH

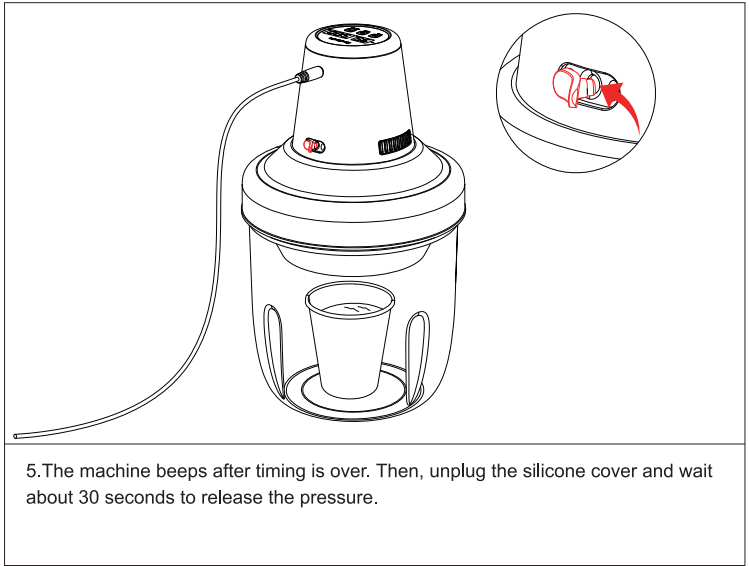

5. The machine beeps after timing is over. Then, unplug the silicone cover and wait about 30 seconds to release the pressure.

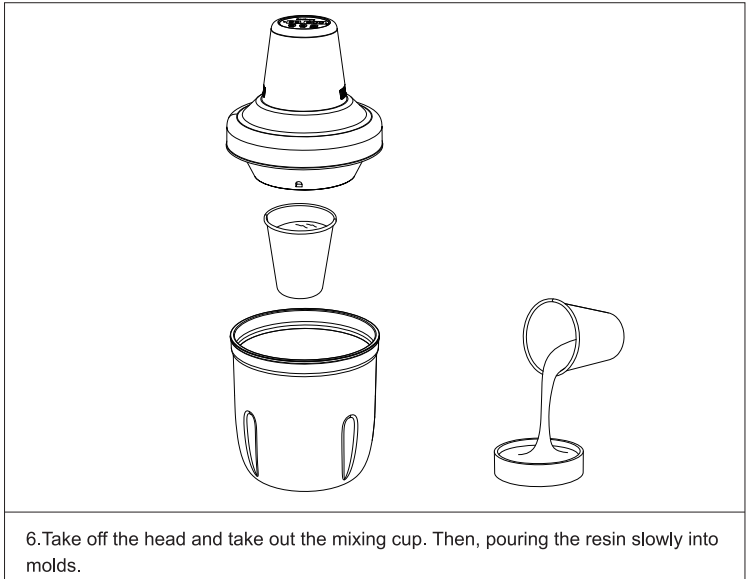

6. Take off the head and take out the mixing cup. Then, pouring the resin slowly into molds.

I CONTROLS

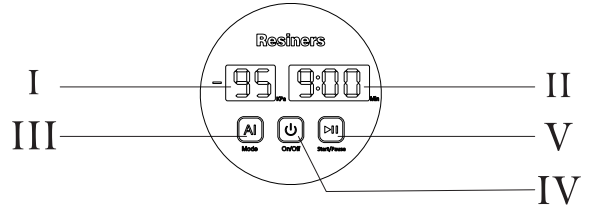

- I Degree of Vacuum** When the program starts, the degree of vacuum will display real-timely.
- II Auto Timer** When the program starts, the timer goes in minutes and seconds.
- III Two Modes Switch** There are two timer modes to select: 5 mins and 9 mins.
- IV Power Button** Tap the power button to turn on/off the machine.
- V Pause Button** It is allow to pause the program at any time by tapping the pause button.

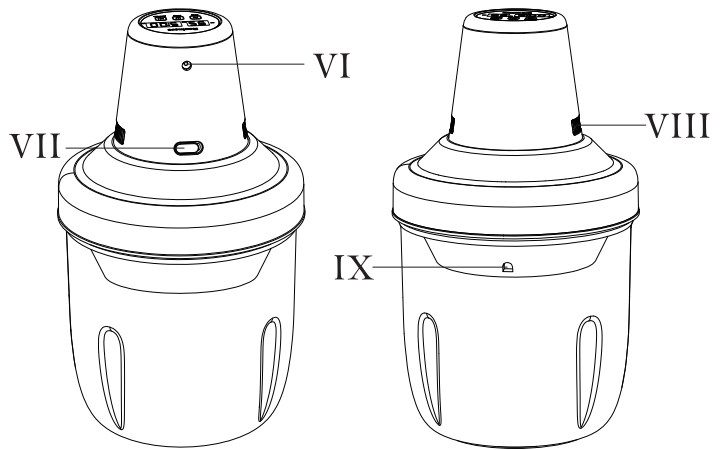

- VI Power Port** Plug in the power cable before use.
- VII Pressure Hole** Make sure the silicone cover is plugged before use, and unplug it after use.
- VIII Cooling Hole** Do not block its cooling hole or hinder its heat dissipation.
- IX Degassing Hole** Keep the degassing hole clean and clear before and after use.

II INSTRUCTION FOR USE

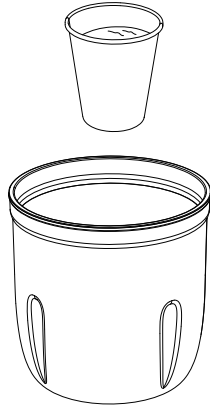

1. Take off the head, put the mixed resin cup into the container. Do not mix resin too full. Otherwise, it may spill out while vacuuming or bubbles may be stuck inside due to resin overheating.

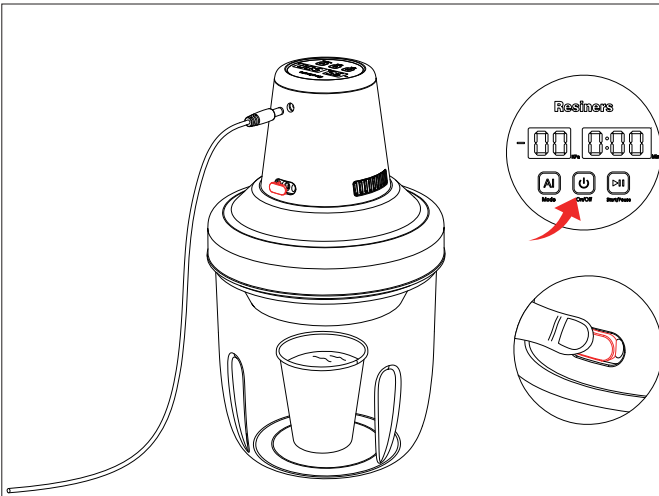

2. Close the head, plug the silicone cover, tap the power button.

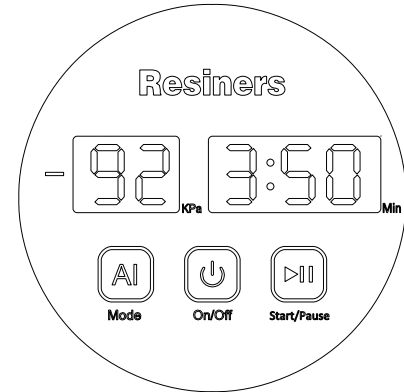

3. Select 5 mins or 9 mins by tapping the AI button. After 3 seconds, the machine starts to work. When the pressure reaches -92 kPa, the bubble starts to eliminate. Normally, it takes about 1 minute to reach -92kPa and one and half minute to reach -95kPa.



4. The process of eliminating bubbles is visible. If the bubbles have been removed as you can see, you can pause the timer anytime by tapping the pause button. Or you can repeat the process if the bubbles haven't been eliminated completely when the time is up.