



INSTALLATION MANUAL

RVMP[®] Flex Power[®]

Dual Fuel Installed Generator

For Models:

4000i (4000 Watts) And 5500i (5500 Watts)



(Picture shown here is for reference only)



Authorized for Installation ONLY in Recreational Vehicles Prepped by the RV Manufacturer

With Fuel Lines and a Compartment for Permanent Generator Installs.

Do NOT Install in Any Other Application.

Visit rvmp.co • Copyright© 2024 RV Mobile Power, LLC. – All Rights Reserved.



Read this manual carefully before operation.

This manual includes important guidance for safety operation.

1.0 SAFETY	2
2.0 INSTALLATION STANDARDS AND CODES	4
3.0 GENERATOR DIMENSIONS (WITHOUT FRAME)	6
3.1 HANGING FRAME DIMENSIONS	7
4.0 LIFTING AND HANDLING GENERATOR	8
5.0 LOCATION, MOUNTING, AND VENTILATION	9
5.1 HANGING FRAME INSTALL	10
5.2 FLOOR MOUNT INSTALL	11
5.3 PEDESTAL INSTALL	12
5.5 VENTILATION	13
6.0 EXHAUST	19
7.0 PROPANE CONNECTIONS	24
7.1 GASOLINE FUEL CONNECTIONS	26
7.2 GASOLINE VAPOR CONNECTIONS	28
8.0 ELECTRICAL CONNECTIONS	29
8.1 BATTERY CONNECTIONS AND GROUNDING	32
8.2 WIRING DIAGRAMS	33
8.3 ELECTRICAL WIRING FOR REMOTE CONTROL FUNCTIONS	37
9.0 INSTALL CHECKLIST AND STARTUP	38
9.1 Engine Oil Recommendations	39
9.2 Starting Batteries	39
9.3 Generator Initial Start-Up Procedure	39
10.0 Model Identification and Technical Specifications	40
11.0 Warranty Info	43

1.0 SAFETY

Read and understand all instructions before installing or operating this product. Adhere to all safety labels. This manual provides general instructions. Many variables can change the circumstances of the instructions, i.e., the degree of difficulty, existing equipment, operation and ability of the individual performing the instructions. Failure to correctly follow the provided instructions may result in death, serious personal injury, severe product and/or property damage and may void portions of the warranty (See Owner's Manual for warranty info). We recommend that installation is performed by a qualified and experienced RV technician.

This manual cannot provide instructions for every possible scenario, but provides the general instructions, as necessary, for effectively installing and using the generator in most situations. If you have any questions, please contact us at:

RV Mobile Power, LLC
Phone: (855) HAPPYRV
Email: support@rvmp.co
www.rvmp.co

⚠ FIRE SAFETY NOTICE

Keep multi-class ABC fire extinguishers handy. Class A fires involve ordinary combustible materials such as wood and cloth. Class B fires involve combustible and flammable liquid fuels and gaseous fuels. Class C fires involve live electrical equipment.

⚠ WARNING

The "WARNING" symbol above is a sign that a procedure has a safety risk involved and may cause death or serious personal injury if not performed safely and within the parameters set forth in this manual.

- **Failure to follow instructions provided in this manual may result in death, serious personal injury and/or severe product and property damage, including voiding all or portions of the warranty.**

- Do not operate equipment when mentally or physically fatigued or after consuming alcohol or drugs.
- Do not use starting fluids which can cause an explosion and may result in death, serious personal injury and/or severe product and property damage. Do not use evaporative starting fluids. They are highly explosive.
- Installing or maintaining a generator can cause severe personal injury. Wear personal protective equipment including safety glasses, hard hats, steel-toed shoes and protective clothing when working on equipment.
- Benzene, found in some fuels, and used engine oils have been identified by some state and federal authorities to cause cancer or reproductive toxicity. Do not ingest, breathe fumes or come into contact with gas or oil when checking, draining or adding gas and oil.
- Hot, moving and electrically-live parts can result in death, serious personal injury and/or severe product and property damage. Only trained and experienced personnel should make adjustments while the generator is running. Otherwise, adjustments should be made only when the generator is not running.
- Moving parts can catch on loose clothing items or jewelry. Do not wear loose clothing or jewelry near moving parts including shafts, fans, belts and pulleys.
- Moving parts can seriously injure body appendages, including fingers. Keep hands away from moving parts. Keep protective guards in place over fans, belts, pulleys and other moving parts.
- Improperly installed electrical connections may result in death, serious personal injury and/ or severe product and property damage. Electrical connections must be made by trained and experienced electricians in accordance with applicable codes.
- Back-feeding to shore power may result in death, serious personal injury and/or severe product and property damage. The generator must not be connected to shorepower or any other source of electrical power. An approved switching

device must be used to prevent interconnections and serious damage to the generator.

- Operating, servicing and maintaining and maintaining this equipment can expose you to chemicals, including engine exhaust, carbon monoxide, phthalates and lead, which are known to the State of California to cause cancer and birth defects or other reproductive harm. To minimize exposure, avoid breathing exhaust, do not idle the engine except as necessary, service your equipment in a well-ventilated area and wear gloves or wash your hands.
- Do not install generator on a watercraft or boat. Such an installation might violate U.S. Coast Guard regulations and may lead to damage, fire, injury, or death.

⚠ CAUTION

The "CAUTION" symbol above is a sign that a procedure has a safety risk involved and may cause personal injury, product or property damage if not performed safely and within parameters set forth in this manual.

- Always wear eye protection when performing service, maintenance or installation procedures. Other safety equipment to consider would be hearing protection, gloves and possibly a full face shield, depending on the nature of the task.

2.0 INSTALLATION STANDARDS AND CODES

This generator meets the standard for Safety for Engine Generator Sets for Recreational Vehicles, ANSI/RVIA EGS-1. It is highly recommended that this generator be installed by a trained and certified installer with experience in RV generators.

The generator must be installed according to the following standards, as well as any local, state and federal standards. Due to the ever changing nature of standards, it is the responsibility of the installer to have the current editions of these and other relevant standards.

National Fire Protection Association

470 Atlantic Avenue

Boston, MA 02210

- NFPA No. 70, Article 551 – Recreational Vehicles and RV Parks
- NFPA No. 58 – Liquefied Petroleum Gas Code
- NFPA No. 1192 – Fire & Life Safety
- NFPA No. 501C (ANSI A119.2) – Recreational Vehicles

California Administrative Code—Title 25, Chapter 3

State of California Documents Section

P.O. Box 1015

North Highlands, CA 95660

- CSA Electrical Bulletin 946 – Requirements for Internal Combustion Engine–Driven Electric Generators for Use in Recreational Vehicles

Other possibly applicable standards for consideration:

ANSI A119.2

ANSI/RVIA–EGS–1

FMVSS 301

Recreational Vehicle Industry Association

14650 Lee Road

Chantilly, VA 22021

CAN/CSA–Z240

Recreational Vehicles Bulletin 946

Canadian Standards Association

Housing and Construction Materials Section

178 Rexdale Blvd.

Rexdale, Ontario, Canada M9W 1R3

3.0 GENERATOR DIMENSIONS (WITHOUT FRAME)

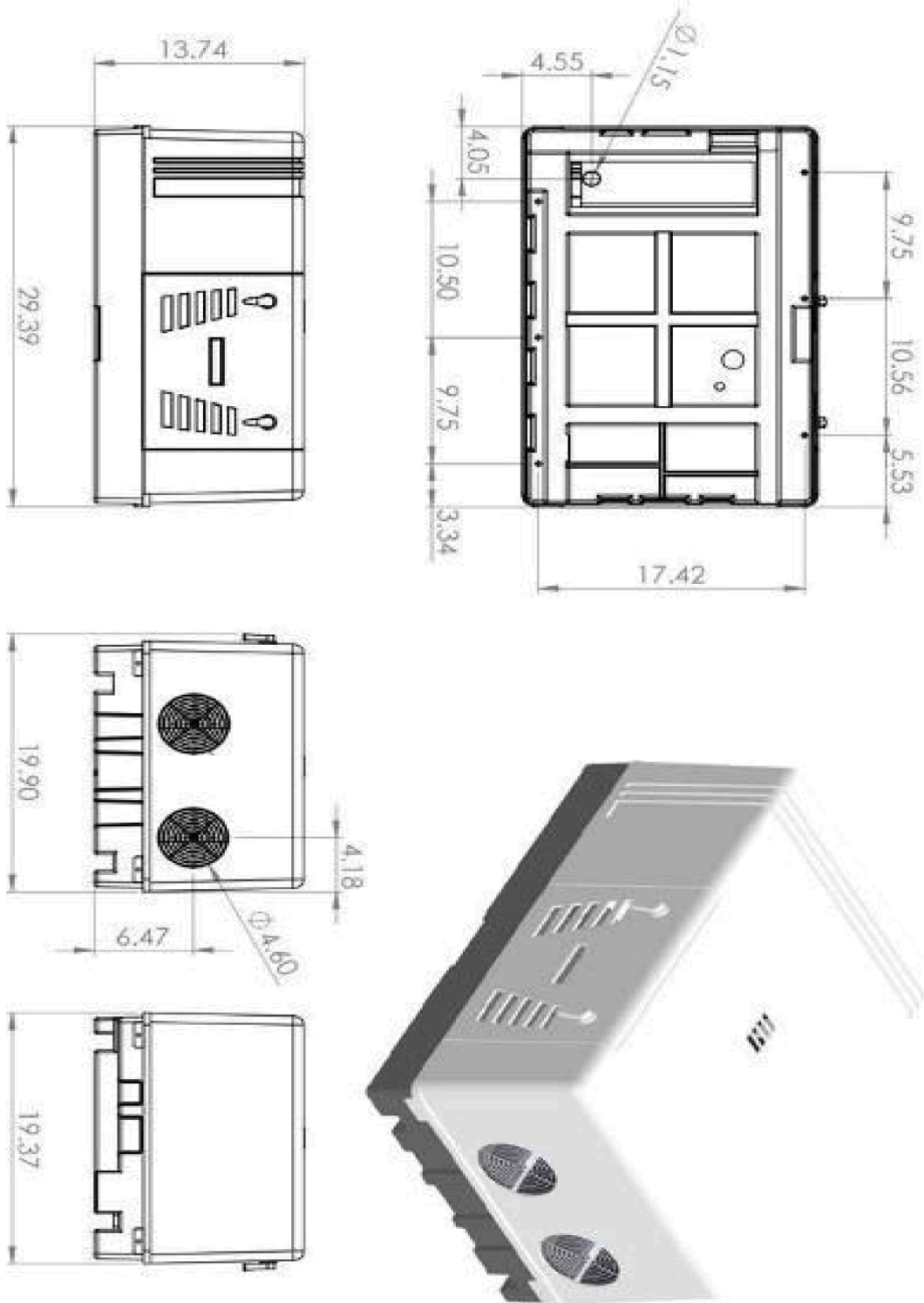

3.1 HANGING FRAME DIMENSIONS

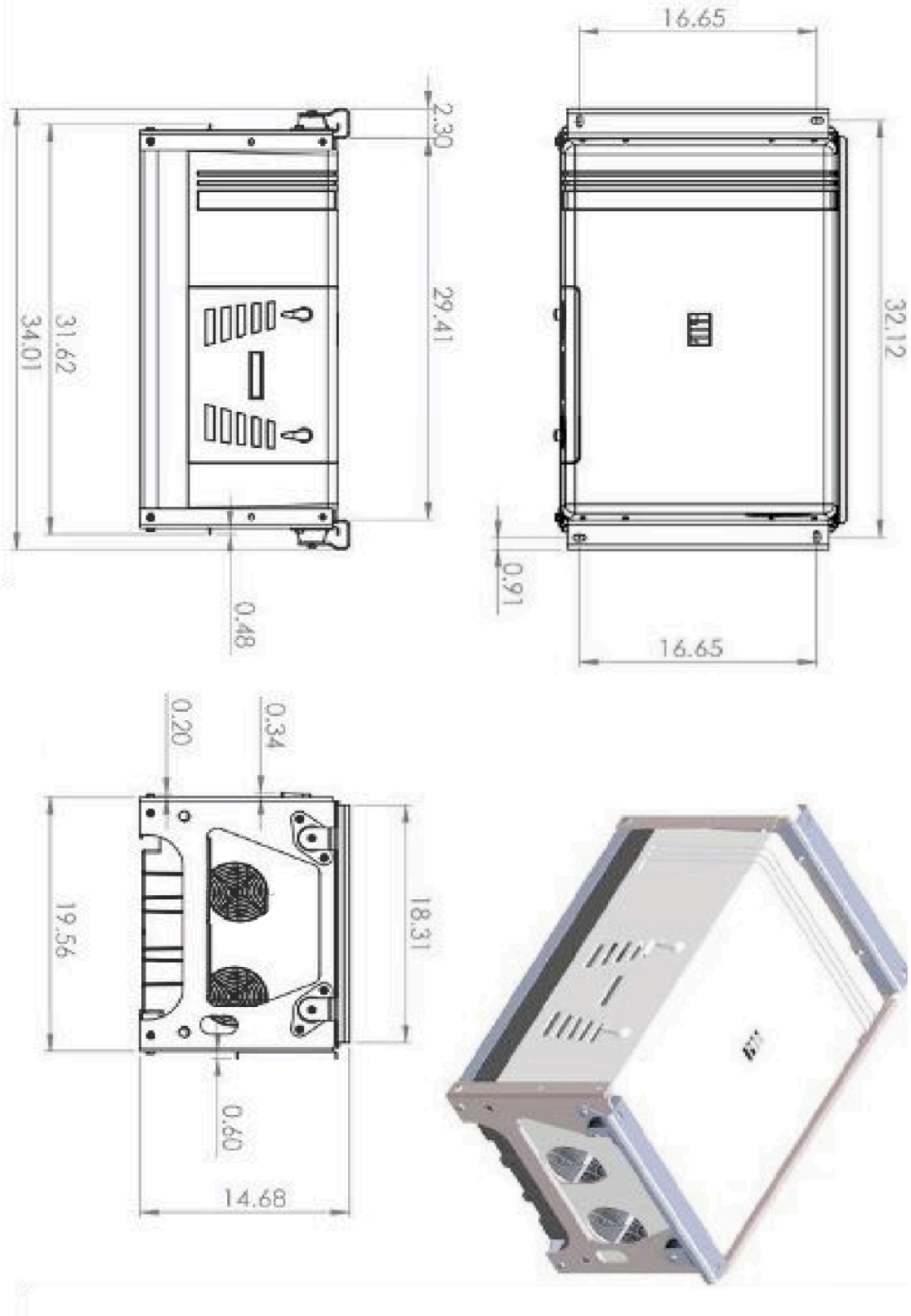

4.0 LIFTING AND HANDLING GENERATOR

When lifting a generator without a mounting frame, the generator should only be lifted from the bottom. The generator should never be lifted by the housing. A solid surface, a pair of forks, or a pair of straps can be placed underneath the generator to properly lift from the bottom. Care should be taken to ensure that the generator is held horizontally during handling and is not tipped which could spill oil. Care should also be taken to ensure that no fork or strap contacts the exhaust outlet on the bottom of the generator, as this contact during lifting/moving could bend or break connections in the muffler and exhaust system. Further care should be taken during handling to ensure that fuel/LP lines are not pinched or crushed.



When lifting a generator with a mounting frame, the generator can be lifted either by A) the upper frame where the mounting holes are located or (B) from the bottom.

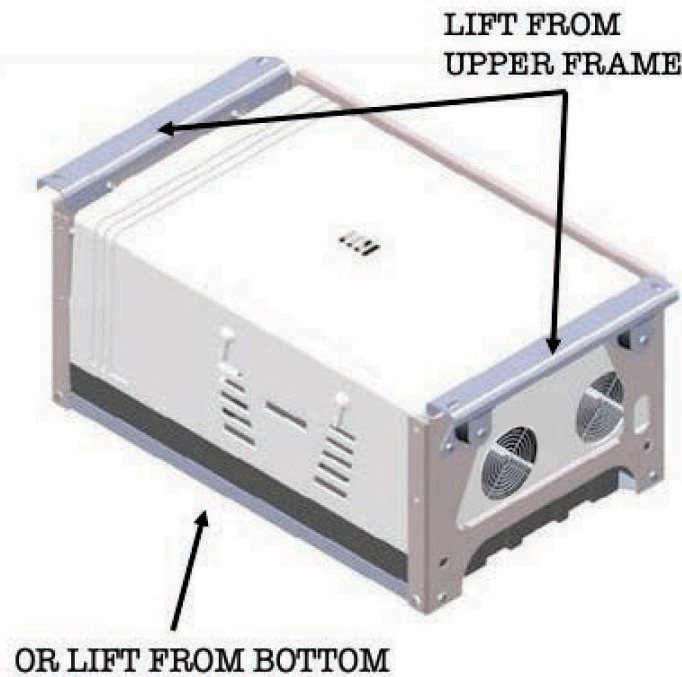

5.0 LOCATION, MOUNTING, AND VENTILATION

This generator is designed to be installed into or onto a vehicle and must be securely mounted to the vehicle. **For safety reasons, to prevent unintended access to live parts, it must be installed within a compartment that can be locked or requires a tool in order to open the compartment.** It has to be installed in an area safe from road debris and must be guarded in such a way that the vehicle cannot be damaged by heat or vapors. The generator has to have exhaust, fuel, and electrical all installed correctly to safely function. A proper location must include all of the following:

- Enough space based on the generator dimensions shown above.
- Enough space to connect and disconnect fuel lines, a remote control wiring harness, and AC power output lines.
- Enough space to access the front control panel for starting/stopping the generator and performing all periodic maintenance.
- Separation from any flammable vapors or liquids, including fuel tanks and batteries, to prevent the generator from igniting these substances.
- Access to the bottom of the generator for draining oil, removing spark arrestor on muffler, and

installing exhaust.

- Ground clearance of at least 12 inches.
- Space below, above, and to the sides of the generator for adequate cooling air flow.
- Placed within a compartment that is either lockable or requires a tool to open.

⚠ WARNING

Supporting structure must be strong enough to hold and secure the generator. Insufficient structure may cause damage to the vehicle or the generator may become detached from the vehicle causing serious damage, injury, or death.

The generator weighs approximately 117 lbs (4000i model) or 161 lbs (5500i model) and must be installed in a location that can support the weight of the generator, as well as the motion of the generator and the added forces of the generator when traveling (approx +/-1G Force vertical and +/-3G Force horizontal). Mounting of the generator will be dependent on the design of the structure, but fasteners should not intrude into the generator more than required. If installed near wheels, install guarding to protect the generator from debris.

5.1 HANGING FRAME INSTALL

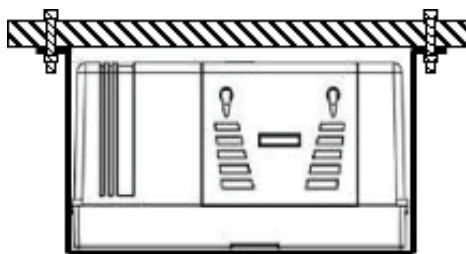

Completely open
(exposed to road)

When hanging the generator below the floor of the RV, use the hanging frame and mounting bolts to hang the generator from the RV floor above. This is the preferred method of mounting the generator as it

allows maximum airflow beneath the generator and to the sides as well as easy access to install the exhaust as well as drain the oil. However, barriers to vapor and fire must be placed between the generator and the floor above. A 26GA fire barrier must be installed to protect the floor. If the floor is plywood, steel must be used to reinforce the mechanical support for the generator. Choose the mounting location so that the generator is not within the approach or departure angles of the vehicle and is above the axle line. If installed near wheels, install guarding to protect the generator from debris. For mounting bolts, use at least $\frac{3}{8}$ " bolts with washers and locking washers, with all parts either galvanized steel or stainless steel. See the dimensions of the hanging frame above to determine the locations for marking and drilling holes for the mounting bolts.

5.2 FLOOR MOUNT INSTALL

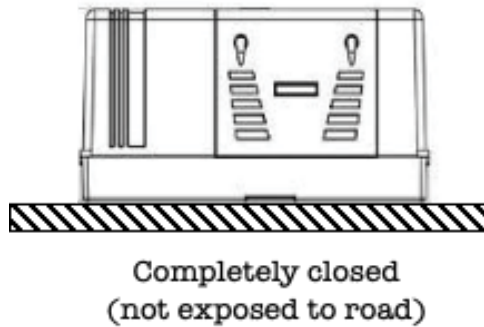

When mounting on the floor of a compartment, adequate ventilation for the generator must be established or the generator will quickly overheat (the hot cooling air exits the bottom of the generator and if it has nowhere to go it will be immediately recirculated into the generator's cooling system on the right hand side). For this reason, it is not advisable to mount the generator directly atop a floor, unless either (1) using the pedestal or modified pedestal install method or (2) removing a substantial portion of the floor to ensure adequate cooling air flow. Both techniques will be described immediately below.

The generator must be installed in a vapor tight 26GA or greater enclosure to prevent both fire and vapors from getting into the vehicle. The entire compartment (except the floor) must be lined with vapor and fire

resistive materials. All seams and openings in the barriers for wiring, mounting screws, etc must be sealed. Appropriate materials must be used (26 gauge steel or equivalent). See NFPA 1192 for more information. If the floor is of a combustible material, such as wood, the compartment and door must be lined with ¼ to ½ inch thick, 4 lb/ft³ density fiberglass thermal insulation with aluminum foil facing at least 0.001 inch thick. Secure the insulation every 12 inches to the surfaces being protected by mechanical fasteners with washers at least 1 inch in diameter.

Acoustic and/or thermal insulation may be used but must be self-extinguishing at 200 degrees F and do not place these materials below the generator as they can absorb fuel and oil and will keep the heat from the hot air coming out of the bottom of the generator from escaping. All fuel and electrical lines must be properly protected when routing so that they cannot be cut on raw metal. Any and all openings must be sealed to prevent vapors from entering the vehicle.

5.3 PEDESTAL INSTALL

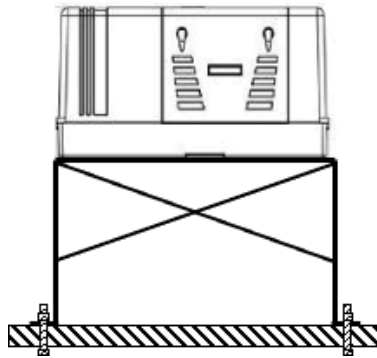

For this installation technique, the vertical portions of the frame are inverted so that the generator now sits atop the frame. This will require additional vertical space within the compartment as the generator with frame assembly is now twice as tall. Be sure there is adequate room for this technique before continuing.

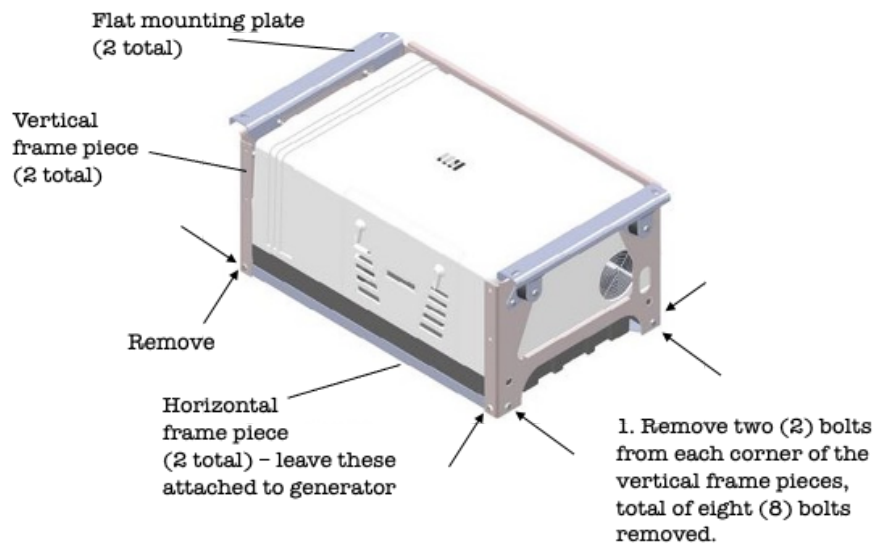

To assemble this design, remove the two (2) bolts at each corner (eight total) of the frame and detach the vertical frame pieces from the horizontal frame pieces. Leave the horizontal pieces attached to the generator. Flip the vertical pieces upside down so that the flat mounting plates are now flat against the floor. Now reattach the eight (8) bolts at the corners of the frame to reconnect the generator to the vertical pieces. Mark and drill holes for the mounting bolts, based on the dimension shown above for the frame. Mount the assembly to the floor using mounting bolts. For mounting bolts, use at least $\frac{3}{8}$ " bolts with washers and locking washers, with all parts either galvanized steel or stainless steel.

5.5 VENTILATION

As noted above, the generator must have adequate cooling air flow in order to cool itself, especially when running in very hot ambient temperatures or when running at the same time as a chassis engine. Ideally, the entire bottom of the compartment is open to the road to ensure the maximum amount of fresh cooling air is ingested into the generator and the hot air can be easily exhausted out of the bottom (Note: this hot air is cooling air and is different from the combustion exhaust that is piped out separately from the muffler and is described further below). See the diagram below which illustrates the flow of cooling air into and

out of the housing for the generator and note where the cold air enters and hot air exits, keeping these flows separated from each other is critically important to prevent overheating and increase the life of the generator.

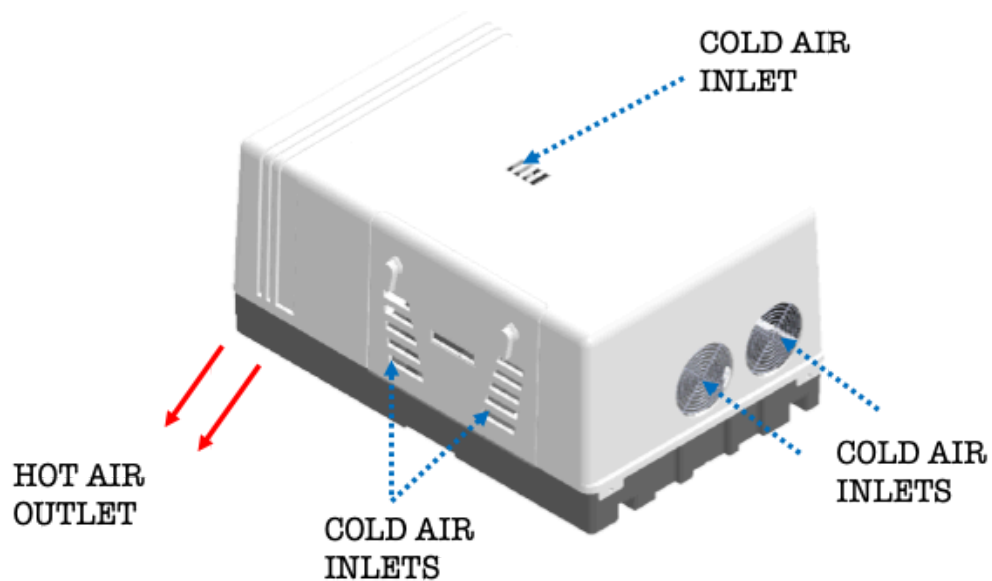

Even if the entire bottom of the compartment is open to the road, it is still critical to ensure adequate clearance at the top of the generator housing for the cold air inlet, so there should be at least two (2) inches of space (preferably more but when using the hanging method this is sometimes not possible) between the cold air inlet at the top of the generator and the surface immediately above. Further, even if the entire bottom of the compartment is open to the road, it is still critical to ensure adequate clearance for the cold air inlets that are positioned on the removable door of the generator. These inlets are also important so be sure to maintain at least two (2) inches of space (preferably more) between the cold air inlets on the door and the next surface. Preferably, if the cold air inlets on the door are very close to the interior surface of the compartment door, a vent should be installed within the compartment door and adjacent to the cold air inlets on the door so that outside cool air can be easily drawn into the cold air inlets on the front door of the generator. This vent should preferably be between 20in² and 40in² in area.

When positioned within a closed compartment having a floor, the compartment must be heavily vented with fresh air, so that large portions of the floor of the compartment will need to be removed. As shown below, several areas will need to be removed for both airflow purposes as well as access to the oil drain.

Note the locations and dimensions (all shown in inches) of each of the features above, as they will need to be removed from the floor of the compartment.

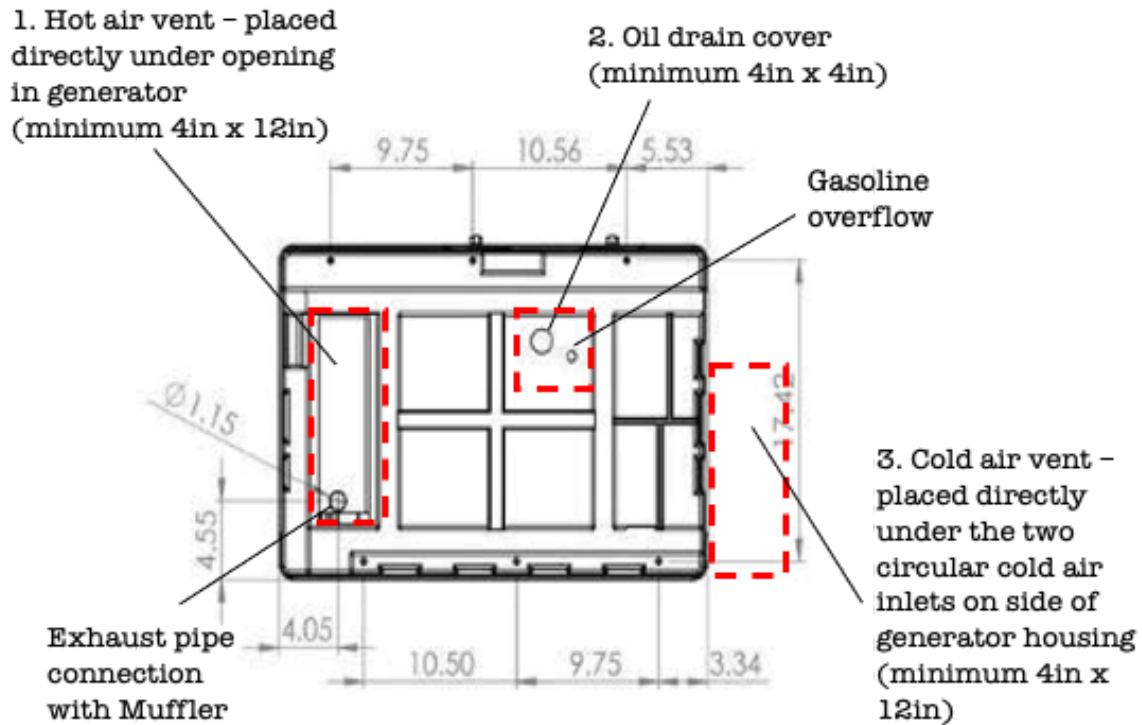

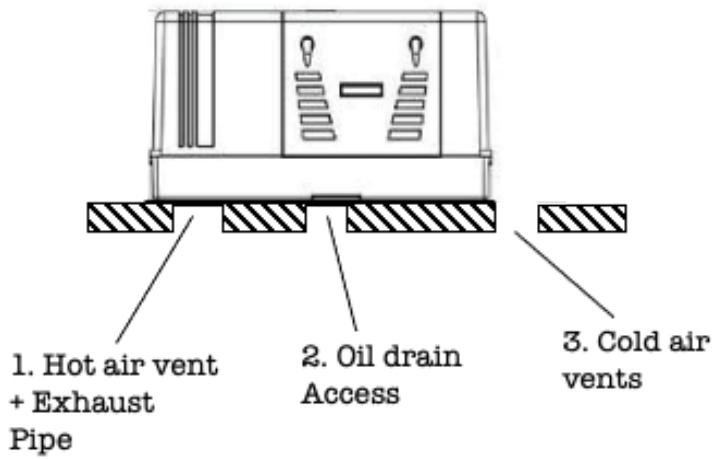

1. Mark the location for the hot air vent and the exhaust pipe to pass through the substructure and remove this portion of the substructure.
2. Mark the location for the oil drain and gasoline overflow to pass through the substructure and remove this portion of the substructure.
3. Mark the location for the cold air vent for plenty of cold air to enter the compartment.
4. Remove these areas from the substructure.

Once these ventilation and oil drain portions are removed from the substructure, the location of the mounting bolts should be marked and drilled out of the substructure. The generator contains a set of three (3) female threaded holes along the front and rear edges of the generator for a total of six (6) mounting holes that accept M8 10mm bolts. The location of these threaded holes are shown below with reference to the ventilation and oil drain portions removed above.

**Female Threaded Hole
Locations For Mounting Bolts**

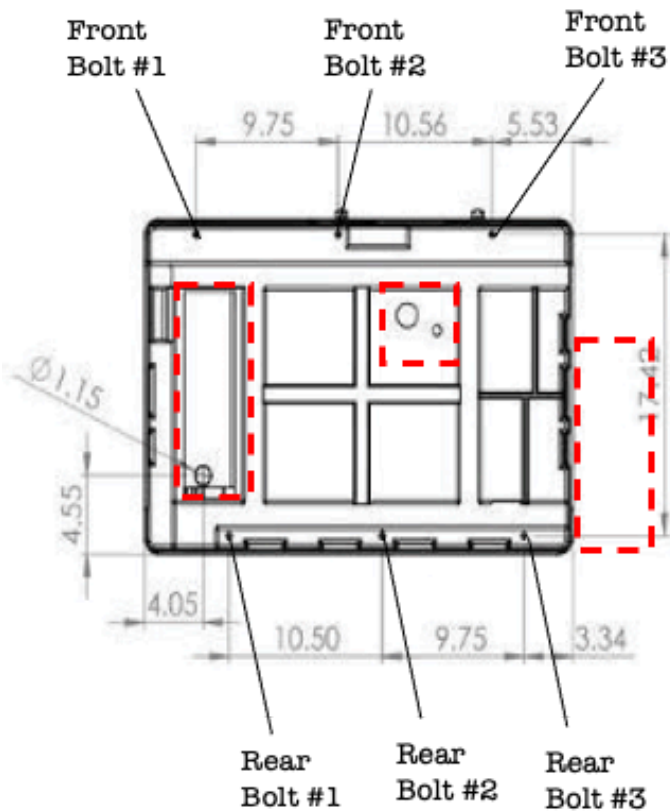

5. Mark the locations of the female threaded holes across the front of the generator which receive bolts (Front Bolts #1 - #3).

6. Mark the locations of the female threaded holes across the rear of the generator which receive bolts (Rear Bolts #1 - #3).

7. Drill one-half inch ($\frac{1}{2}$ ") diameter holes at each location.

Once the ventilation, oil drain, and mounting bolt portions of the floor/substructure have been removed, the generator can be bolted into place. Position the generator above the cutouts and mounting holes and ensure everything lines up before bolting the generator into place. If anything does not align properly, specifically the ventilation holes and access to the exhaust attachment at the muffler (ensure that there is plenty of room to install the exhaust to the muffler and attach an exhaust clamp), remove the generator and mark the additional substructure that needs to be removed. Once this is removed, replace the generator in its location and check to ensure the accuracy of all ventilation and mounting bolt locations.

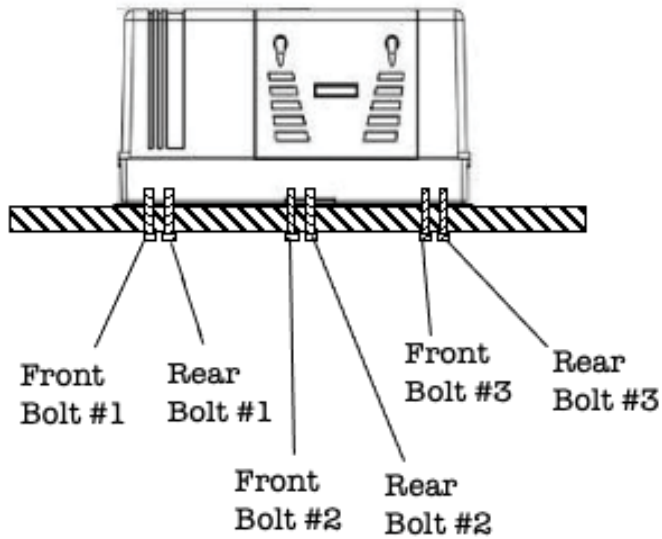

8. Place the generator atop the cutouts for the vents and the locations of the mounting bolt holes.

9. Install three (3) M10 bolts across the front of the generator (Front Bolts #1 - #3).

10. Install three (3) M10 bolts across the rear of the generator (Rear Bolts #1 - #3).

11. Ensure that each bolt is long enough to pass through the substrate and engage adequately with the female threaded holes in the generator.

12. Use flat washers as well as locking washers on each bolt for a secure connection.

In some applications, especially where rodents and animals are frequently attempting to enter the compartment, a screen/mesh/louvers may be attached to cover the ventilation portions as well as the access to the oil drain. This is optional. Be sure that any covering used does not become clogged with dirt, dust, or debris. Be sure to check any coverings to ensure that airflow remains unimpeded and clean or replace any coverings that become restricted. Airflow to your generator is critical to its lifetime and performance.

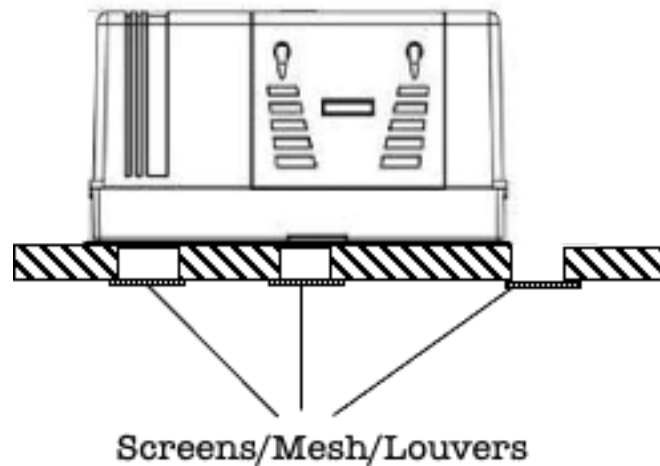

6.0 EXHAUST

⚠ WARNING

EXHAUST GAS IS HOT AND DEADLY. Never inhale exhaust gas. Always route exhaust pipes outside of the vehicle and terminate the tailpipe at the appropriate location. Use only approved materials for exhaust pipe and always use proper clamps and hangers and ensure that there are no leaks. Never mount the exhaust where it could be damaged or punctured.

⚠ WARNING

DO NOT MODIFY MUFFLER. Modification or alteration to the muffler will void the US Forest Service approval of the muffler. A fire can be started when using a generator without a proper spark arresting exhaust system. The person making any modification or knowingly using a modified muffler is liable for any warranty, injury, or damage caused by a modified muffler.

When installing the exhaust system, use rigid 18 gauge steel or greater with 1.25" OD (muffler outlet is 1.13" OD). While the directions below show separate pieces being connected to form the exhaust system, RVMP (and others) may offer exhaust kits with a single pipe already formed with a 90 degree bend. When replacing an old generator, if the previous exhaust was not rusted out or otherwise damaged, it can be re-used for the FLEX POWER generator.

1. Cut a hole (if necessary) into the floor beneath the outlet of the muffler, located on the bottom side of the generator.

HANGING INSTALL

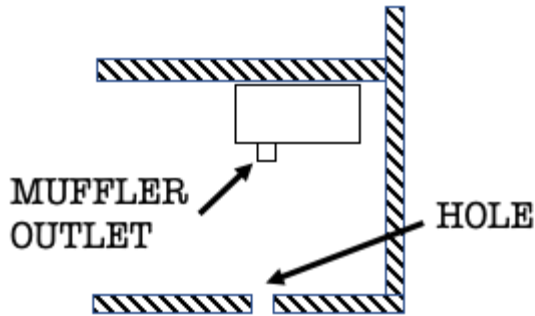

FLOOR INSTALL

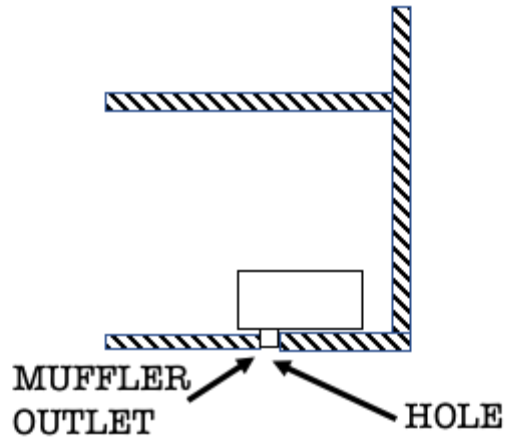

2. Connect one or more vertical pipes to the outlet of the muffler, running downward vertically through the hole. Use only proper U-bolt exhaust clamps to connect to the muffler outlet and any additional pipes.

HANGING INSTALL

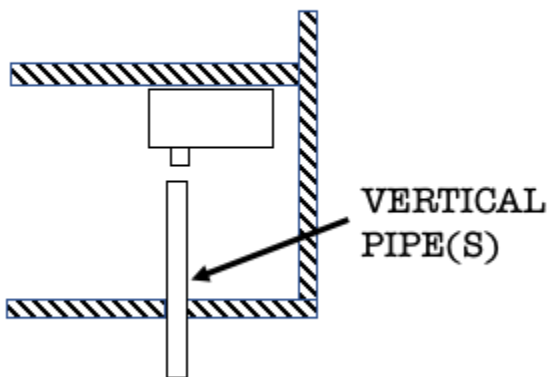

FLOOR INSTALL

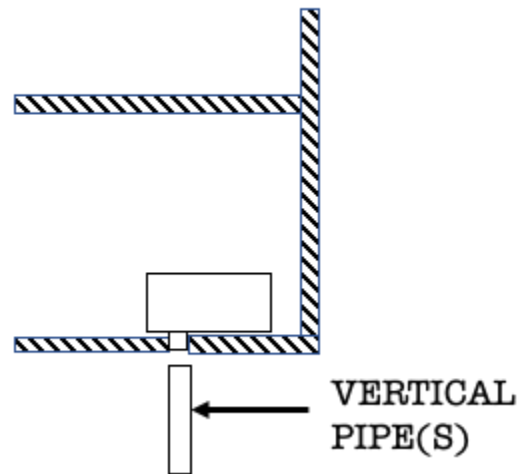

3. Connect a 90 degree elbow pipe to the vertical pipe(s), again using proper U-bolt exhaust clamps only.
4. Connect a series of horizontal pipes to route the exhaust to the nearest periphery of the vehicle, again using proper U-bolt exhaust clamps only. Ensure that the tail pipe extends beyond the body perimeter of the vehicle.

HANGING INSTALL

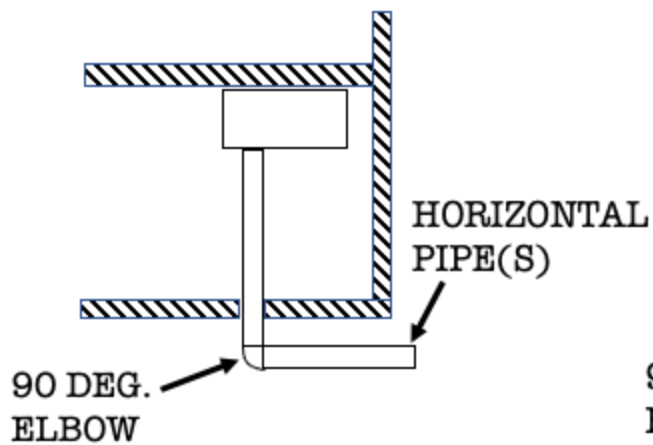

FLOOR INSTALL

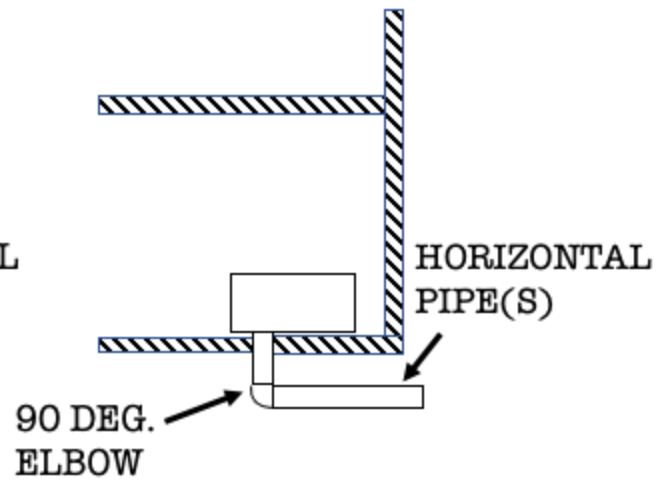

5. Ensure that the tail pipe extends far enough away so that exhaust gas cannot be trapped beneath the vehicle, at least 1 inch beyond the perimeter of the vehicle. See the figure below for measuring the body perimeter of curved vehicles, as well as NFPA 1192 Section 6.4.3 for more details. "Line A" provides a line beyond which the exhaust termination opening must extend to satisfy the standard and this is determined by drawing a vertical line through the tangent point determined by "Line B." Whereas "Line B" is determined by projecting a 45 degree angle from the horizontal plane created by the ground to where it is tangent to the vehicle wall surface.

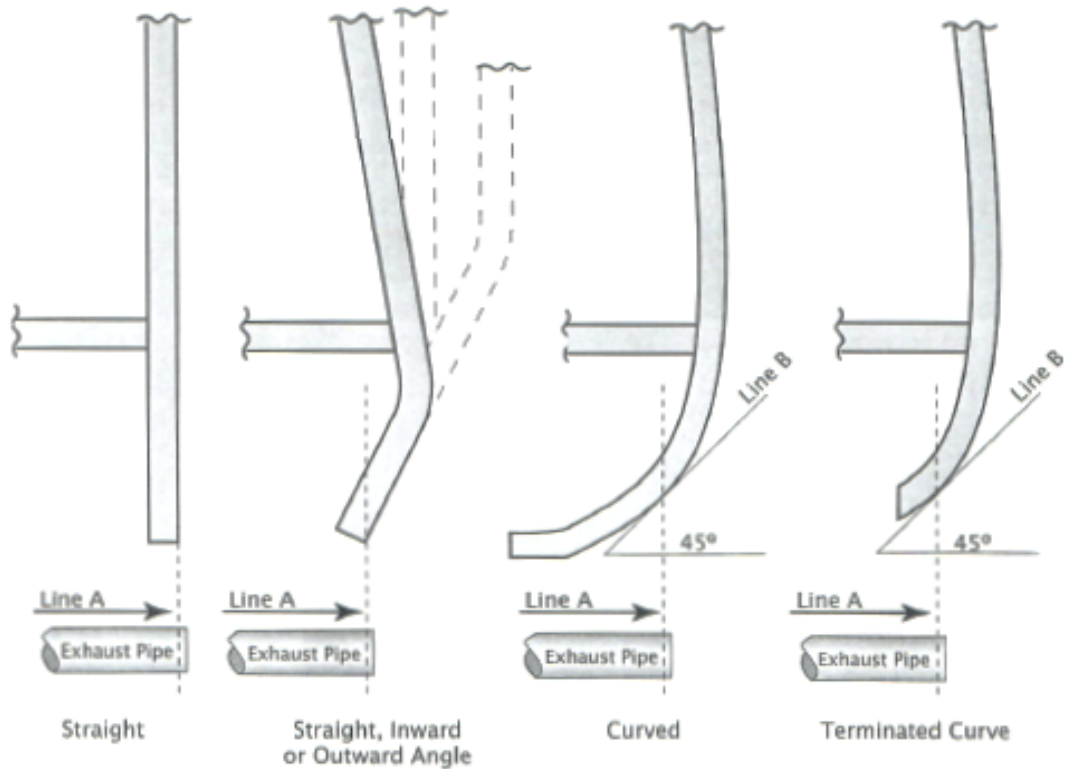

6. Ensure adequate road clearance so that the exhaust cannot be damaged by road bumps or deflation of tires. The road clearance for areas that are not found between the wheels of the vehicle can be measured by establishing a front and rear wheel departure line, which is a straight line from the front and rear tire-road interface to the front and rear bumper respectively. See Figure below. All exhaust pipes should be placed as high above this line as possible.

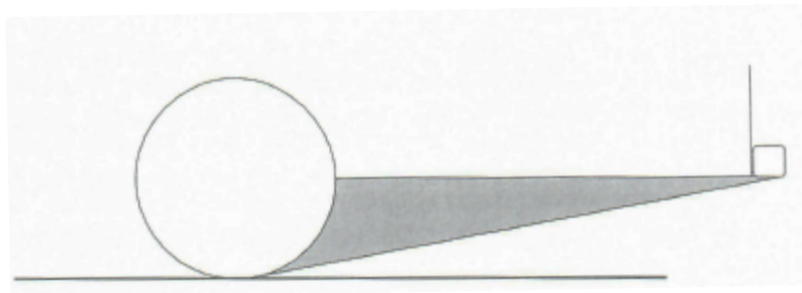

7. Install skid bars to provide additional protected area for exhaust pipe (if necessary).

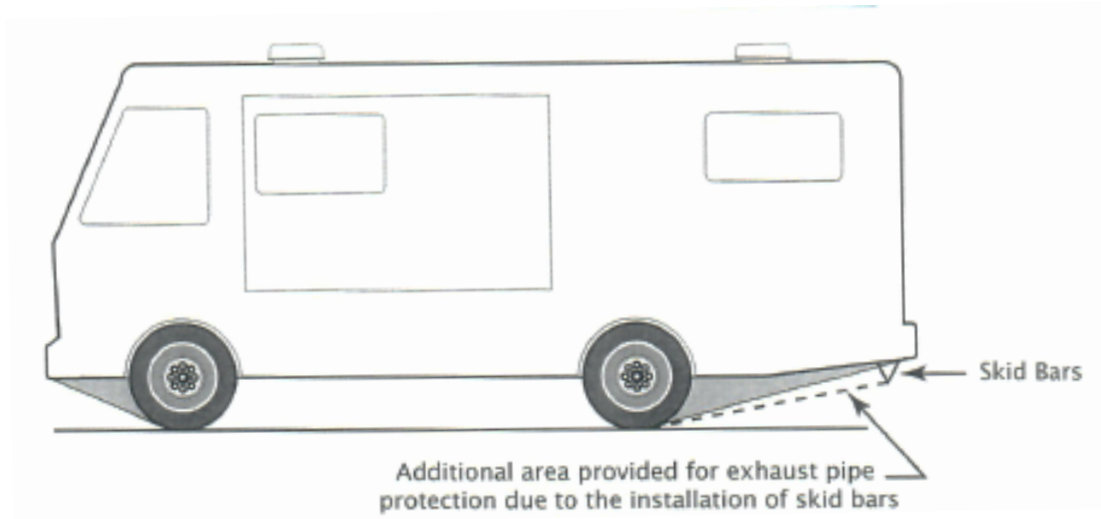

8. Ensure that no unsealed air passage into the vehicle is located within 6 inches of the exhaust pipe termination. This includes but is not limited to: 1) power cord hatches that have an air passage to interior, 2) windows, 3) city water fill that has a communicable air passage, 4) storage compartment doors where the compartment is not sealed to the interior and 5) entry doors. However, unventilated compartment doors that are sealed with sealing materials (gaskets, foam tape, or equivalent) are not considered openings, and therefore are exempt from this requirement. See figure below. “Door A” requires the entire compartment to be sealed vapor-tight to the interior of the vehicle. “Door B” does not require the compartment to be sealed vapor-tight to the interior of the vehicle.

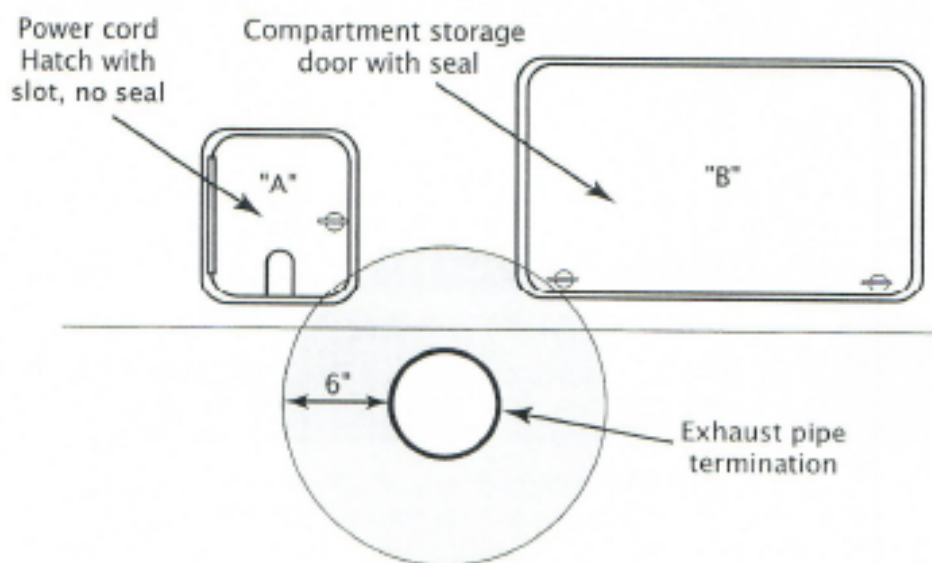

9. The exhaust may terminate beneath a slide out only if the slide out is at least 36 inches vertically

away from the exhaust, measured from the exhaust to the bottom of the slide out. However, the exhaust termination cannot be placed below a slide out that is less than 36 inches vertically from the exhaust termination.

10. Support the exhaust pipe at least every 3 feet with proper exhaust hangers and ensure a slight downward slope in the horizontal pipes ($\frac{1}{4}$ inch for every 3 feet) to allow drainage out of the end of the exhaust pipe. Place an exhaust hanger as close to the exhaust pipe termination as possible.
11. Do not route exhaust near fuel lines or other combustible materials.
12. Do not leave exhaust termination upturned to collect moisture.
13. Do not use flexible exhaust pipe.
14. Do not connect the generator exhaust to the exhaust for the vehicle or any other exhaust.

Exhaust Recirculation Test

It is recommended to check that the generator is not recirculating the exhaust gases or the hot air off the engine after installation. After the generator has been completely installed, in an outdoor space without wind and relative temperature, run the generator for an hour with all of the doors and cabinets shut and the exhaust vented as designed. Place a medium load demand (15–20 Amp) during this time. Using a thermocouple measure the air at the inlet fan on the side of the generator. The temperature should level out within the hour. If the temperature does not level out, but instead continues to increase and increase, check to see if the exhaust is correctly vented away or there is enough inlet air being brought in.

7.0 PROPANE CONNECTIONS

⚠ WARNING

Propane gas (LP gas) can cause asphyxiation, and is highly flammable and combustible. Propane gas can cause injury, damage, or death if improperly handled. Never handle around fire, sparks, or any other ignition source. Never route any propane lines near electrical wiring or heat producing components. Always keep fire prevention equipment on hand when working with propane. Be aware of and trained on the various dangers of working with propane gas. Correct procedure is laid out in

NFPA 58, Sect. 1.6. It is recommended that all work on the propane system is done by experienced and qualified personnel.

⚠ WARNING

Over pressurization of the propane system can cause damage to the equipment and will hinder the ability to seal the system. This can cause leaks and potentially asphyxiation, fire, damage, and death. If the fuel system is improperly sized, flameout can be caused, leading to leaking of propane and fire, asphyxiation, damage, and death. The system must be properly designed to prevent this. Improper testing of fuel system can lead to ignition of propane, causing fire, damage, and death. A person properly trained to adjust the system is required if the propane system needs any modification.

The propane system should be plumbed in seamless steel piping with flared ends. Use the following sizes according to length for determining proper pipe size.

PIPE SIZE	MAX LENGTH
3/8" ID	3 FT
1/2" ID	15 FT

Flexible hoses should only be used at the generator and at the propane tank to make connections. Use only low permeation fuel hoses rated for propane. **Attach the flexible hose to the generator propane inlet using a 1/2" female 45 degree flare fitting (generator attachment is a male 1/2" 45 degree flare fitting).**

Do not combine or split the generator fuel line with a propane fuel supply line that is already supplying another appliance, as the generator will starve out the rest of the system, due to its large draw with large demands. The propane system needs to be designed to properly supply the appliances and generator under normal operations and conditions, which may demand split systems.

The generator demands a gas pressure range of 9–13 in (229–330mm) water column. Pressure must not exceed this range or could cause damage. Use only with tanks having a manual shutoff valve as well as a two stage pressure regulator. The generator requires a low pressure regulator, do not use a high pressure regulator.

The propane system must be installed using the Standard for Storage and Handling of Liquified Petroleum Gases (NFPA No. 58) as a governing document. The system should be thoroughly checked for leaks after installation and only with approved methods such as soapy water. Every part of the fuel system and all connections should be tested in this manner.

Although properly set up when installed, the propane system may need to be adjusted due to elevation, temperature, and fuel sources.

7.1 GASOLINE FUEL CONNECTIONS

⚠ WARNING

Gasoline vapors can cause asphyxiation or death. Gasoline is highly flammable and combustible and can cause injury, damage, or death if improperly handled. Never handle around fire, sparks, or any other ignition source. Never route any gasoline lines near electrical wiring or heat producing equipment. Always keep fire prevention equipment on hand when working with gasoline. Be aware of and trained on the various dangers of working with gasoline. It is recommended that all work on the gasoline system is done by experienced and qualified personnel.

⚠ WARNING

Gasoline system over pressurization can cause damage to both equipment and the ability to seal the

system. This can cause leaks, fire, damage, and death. Do not connect the generator gas line into vehicle gas lines, as the system can starve or flood the generator, potentially causing damage. If connecting to a vehicle gasoline tank, use a separate drawtube. Connect according to vehicle recommendations and connect at a level higher than the vehicle so as to not run the vehicle out of fuel during operations. Proper fuel line pressure should not exceed 1.5 psi under any circumstances.

This generator is intended for RVs that already have fuel lines ran to the compartment for the generator. RVMP recommends that only trained and experienced installers extend or install any type of fuel line. For fuel lines, the gasoline system should only use ¼ inch ID stainless or low carbon steel tubing (AISI 1008–1010) with double flared fittings to make any long connections. The tubing must allow 150 psi operating pressure and have corrosion resistance equal to or better than hot-dipped zinc galvanized steel.

When connecting to a gasoline tank, connect from the top, to prevent siphoning if a line is damaged. Maximum fuel pump lift is 36 inches, therefore only install with less than 36 inches of lift from lowest fuel level to the generator to ensure adequate pressure to draw fuel. Run fuel lines away from rough edges, heated areas, and electrical lines/connections and properly secure to prevent vibration damage and pinching of the lines.

Connect the fuel system to the generator with a ¼ inch barb fitting. When connecting hoses, use only lubricants without soap such as WD40. Soap can be caught in the carburetor of the engine if used and possibly cause in-operation. For connections at the generator or the fuel tank, use ¼ inch ID (SAE 30–R7) low permeation flexible hose with stainless steel ear clamps only. The hoses in the generator meet US and California standards for gasoline evaporative emissions in that they are low permeation. If making a connection to the generator with fuel hoses, they need to meet the standards for low permeation and evaporative emissions required in California.

7.2 GASOLINE VAPOR CONNECTIONS

When using the generator with a gasoline system, an evaporative system is required to meet some local/regional regulations including CARB and EPA. The generator has been tested and configured to comply with evaporative system configuration as provided at sale. Due to the specific nature of this configuration and the customer's install, it is recommended to contact the proper governing bodies for the specific regulations of this type installation. It is the responsibility of the RV equipment manufacturer OEM to complete the installation of the evaporative fuel system exactly as specified in the CARB and EPA certification for the RVMP generator products. Use only with approved carbon canisters from Delphi: Part Number 17208238 (3.1L, 196g working capacity) and Part Number 17208262 (3.3L, 233.8g working capacity).

This generator is intended for RVs that already have evaporative lines ran to the compartment for the generator, connecting to a carbon canister already installed by the RV equipment manufacturer OEM. RVMP recommends that only trained and experienced installers extend or install any type of evaporative line. For evaporative lines, the system should only use 5/16 inch ID stainless or low carbon steel tubing (AISI 1008-1010) with double flared fittings to make any long connections. The tubing must allow 150 psi operating pressure and have corrosion resistance equal to or better than hot-dipped zinc galvanized steel.

Connect the evaporative system to the generator with a 5/16 inch barb fitting. When connecting hoses, use only lubricants without soap such as WD40. Soap can be caught in the carburetor of the engine if used and possibly cause in-operation. For connections at the generator or the carbon canister, use 5/16 inch ID (SAE 30-R7) low permeation flexible hose with stainless steel ear clamps only. The hoses in the generator meet US and California standards for gasoline evaporative emissions in that they are low permeation. If making a connection to the generator with fuel hoses, they need to meet the standards for

low permeation and evaporative emissions required in California.

8.0 ELECTRICAL CONNECTIONS

⚠ WARNING

ELECTROCUTION DANGER! A generator has high voltages that can cause a severe shock or death. Be aware of what is being touched inside a generator, remove anything that can cause accidental touching, and always work on insulated table and floor to reduce risk of electrical shock when working on the generator.

⚠ WARNING

Incorrect wiring can lead to damage, fire, injury, or death. Be aware of connections inside and outside the generator. Do not make connections to the battery until ready to start the generator, to prevent accidental starting or shorting. Incorrect wiring in battery storage can lead to damage, fire, injury, or death. Venting of battery area is necessary to vent off explosive gasses.

⚠ WARNING

Never connect the generator to a vehicle that can also receive shore power (utility) without a proper transfer switch or power switching / management system. Backfeed to shore power (utility) can cause electrocution or damage to equipment. Any vehicle with provisions for connecting to shore power must have an approved device to keep the generator and utility from being interconnected.

All electrical work should be performed by an experienced and qualified electrician. Be sure that all electrical work conforms to the National Electrical Code (NEC) with properly sized conductors, connections, and junction boxes.

AC Power Output for 4000i Models

For the 4000i model specifically, a set of three (3) AC conductors exit the bottom side of the generator, with the colors and polarity detailed in the chart below.

<u>Wire Color</u>	<u>Polarity</u>
Black (10 AWG)	Hot (+)
White (10 AWG)	Neutral (-)
Green (10 AWG)	Ground

These AC conductors are connected through a 30 Amp breaker to protect the generator. For the initial start up of a new generator, or when starting a generator for the first time in 60 days, be sure to have the 30 Amp breaker set to OFF. Once the generator has started and the engine warmed up (approx. 5–10 minutes of run time), the breaker can be switched to ON which will send the AC power out from the generator. This can help extend the life of the generator. When a generator is brand new, it is best to run the generator with no load for 30 minutes before loading the generator with any appliances.

AC Power Output for 5500i Models

For the 5500i model specifically, a set of five (5) AC conductors exit the bottom side of the generator, with the colors and polarity detailed in the chart below.

<u>Wire Color</u>	<u>Polarity</u>
Black (12 AWG)	20 Amp Circuit Hot (+)
Gray (12 AWG)	20 Amp Circuit Neutral (-)
Green (8 AWG)	Ground
White (10 AWG)	30 Amp Circuit Neutral (-)

The black and gray AC conductors are connected through a 20 Amp breaker to protect the generator. The white and red AC conductors are connected through a 30 Amp breaker to protect the generator. For the initial start up of a new generator, or when starting a generator for the first time in 60 days, be sure to have both the 30 Amp breaker and the 20 Amp breaker set to OFF. Once the generator has started and the engine warmed up (approx. 5–10 minutes of run time), the breaker(s) can be switched to ON which will send the AC power out from the generator. This can help extend the life of the generator. When a generator is brand new, it is best to run the generator with no load for 30 minutes before loading the generator with any appliances.

AC Output Power Connections

If the RV is not capable of accepting shore power, connect these AC conductors to an AC distribution panel which would contain a plurality of breakers for distributing AC power to a plurality of AC appliances on the RV. **Alternatively, if the RV is capable of accepting shore power, these AC conductors must connect to a transfer switch capable of switching between shore power and generator power. A transfer switch must be used with any RV that accepts shore power or backfeeding into the generator can occur and will void any warranty and severely damage the generator.**

The AC conductors are approximately 120 inches long. If these conductors are not long enough to reach the transfer switch or AC distribution panel, then the AC conductors should be routed to a proper junction box where longer conductors can connect to the existing generator conductors and complete the run to the transfer switch or AC distribution panel.

8.1 BATTERY CONNECTIONS AND GROUNDING

⚠ WARNING

Never connect the generator to the battery until ready to start the generator. Never route battery electrical lines with or near fuel lines. Routing battery cables with fuel lines can ignite vapors or fuel and can cause fire and serious personal injury or death.

The generator requires 12V DC power to start and a minimum of 450 CCA is necessary to perform starting at 0 degrees Fahrenheit. Battery(s) must be installed in a proper battery compartment that is vented properly. See ANSI/RVIA LV Section 2-3 for battery compartment venting and proper installation.

Using a single continuous run of positive and negative conductors from the battery to the generator is highly recommended. Size the battery conductors based on the chart provided below. The conductors must be properly sized or the wires could heat up, causing an electrical short or fire. Battery wires should be routed away from any fuel lines. If there is any break in the battery conductors, it must be kept free from corrosion and weather.

<u>Total Cable Length (Distance from battery to generator and back to battery)</u>	<u>Cable Size (AWG)</u>
0 to 45 Feet (0 to 13.7 meters)	6
46 to 60 Feet (14 to 18.3 meters)	6
61 to 80 Feet (18.6 to 24.4 meters)	4

Use proper battery terminal eyelets to connect a positive conduction line and a negative conduction line to the battery, size these conductors based on the table above. Additionally, route a ground conductor from the generator negative DC terminal to the vehicle frame, using a minimum size of #8 AWG. Depending on location, precise install situation, and corresponding NEC, it may also be necessary to route a ground conductor from the negative terminal of the battery to the vehicle frame (again preferably using a

minimum of #8 AWG). Be sure to check all connections with a licensed electrician before starting the generator.

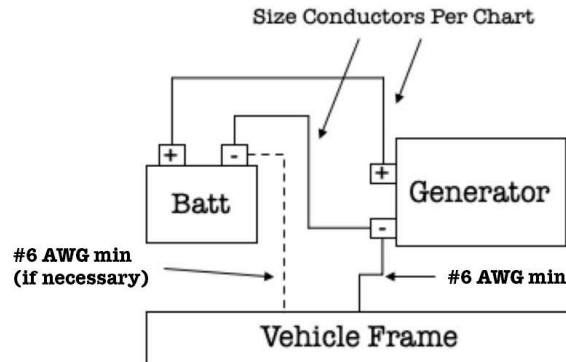

8.2 WIRING DIAGRAMS

4000i – A full wiring diagram for the 4000i model is provided on the sheet below. However, due to the high level of detail provided, some particulars may be difficult to read in this view. Therefore, an electronic version is accessible here with the code provided below.

Scan QR Code to view Wiring Diagram:



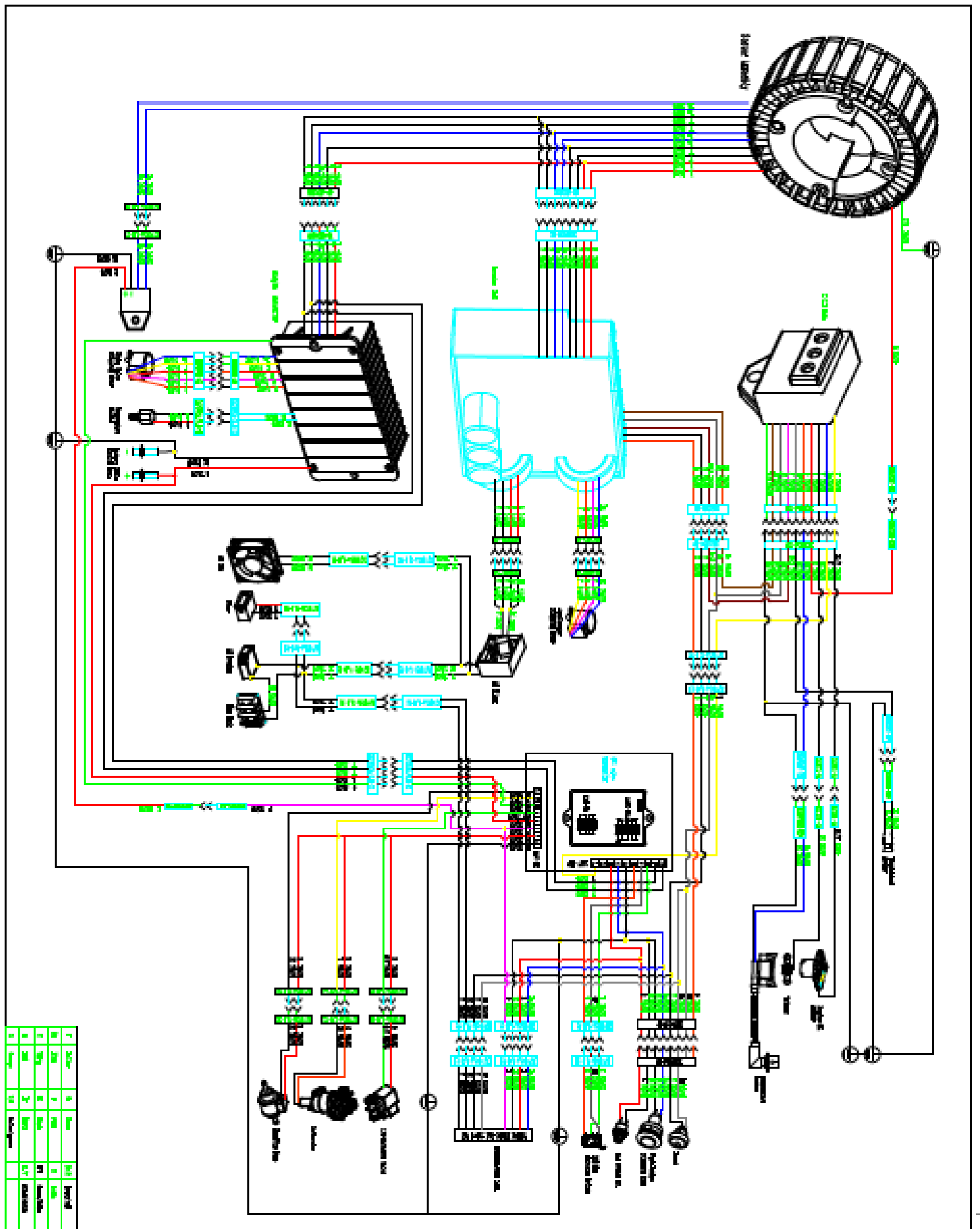

5500i – A full wiring diagram for the 5500i model is provided on the sheet below. However, due to the high level of detail provided, some particulars may be difficult to read in this view. Therefore, an electronic version is accessible here with the code provided below.

Scan QR Code below with smart phone to view Wiring Diagram:



8.3 ELECTRICAL WIRING FOR REMOTE CONTROL FUNCTIONS

The generator is provided with an electrical connector that is designed to connect with the pre-wiring in most RVs for controlling the generator with a remote control. Many include a remote control panel that allows control of various functions of the generator from inside the RV. In many cases, this connector will easily connect to the corresponding connector on the remote control panel, but if not, below is a chart of the corresponding pin functions for each pin on the connector.

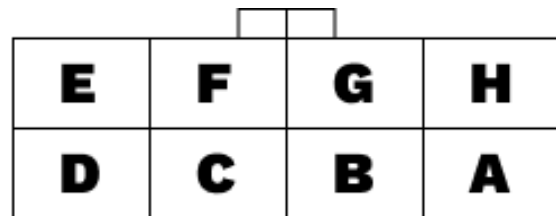
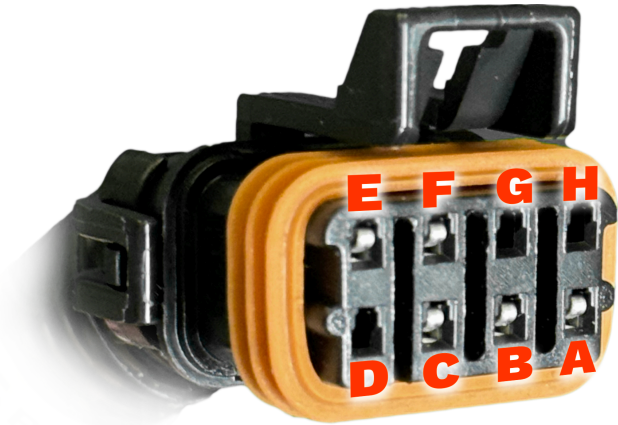

VIEW LOOKING INTO CONNECTOR END

Location	Color	Function	Uses	Connection to make function
A	Black	Ground	Ground	N/A
B	Blue	Start/Stop	Starting and Stopping Generator	D
C	Red	Prime	Prime Gasoline	D
D	Pink	12VDC	12VDC – Light, Timer	D
E	White	Reset +	Reset Overload Condition	F
F	Gray	Reset –	Reset Overload Condition	E
G	N/A	N/A	Do not use	N/A
H	N/A	N/A	Do not use	N/A

Functional Descriptions:

Prime Gasoline – Used to prime the gasoline fuel pump to fill carb before starting

Start/Stop – Works just like the Start/Stop switch on the generator. Used to trigger remote/auto start functions.

Reset – This resets the generator after an overload condition is detected and the generator shuts down for safety.

9.0 INSTALL CHECKLIST AND STARTUP

CHECK ALL OF THESE ITEMS BEFORE STARTUP:

INSTALLATION

- o Properly Sized Enclosure / Clearance
- o Bolted Securely in Location
- o Vents Properly Sized and Located
- o Easy Access to Controls
- o Hoses / Wires Held Fast
- o Hoses / Wires Not Touching
- o No Routing Near Sharp Edges

EXHAUST

- o Vented at Least 1 inch Away From Exterior of Vehicle
- o Vented Away From Any Openings
- o Each Section is Properly Clamped
- o Properly Supported At Least Every 3 Feet
- o Proper Pipe Material

FUELS

- o Fuel Lines Proper Material
- o Proper Regulation of Fuel Pressure
- o Proper Location of Fuel Lines on Fuel Tanks
- o Evaporative system properly installed, if needed
- o System inspected and tested for leaks

ELECTRICAL

- o National Electrical Code Followed for Each Step
- o Connections All Secure

- o Wiring Properly Sized for Battery
- o Wiring properly sized for AC Power Output Lines
- o Ground Connection(s) to Generator Secure
- o Transfer Switch Used When RV is Equipped to Accept Shore Power
- o Remote Controls Installed Correctly, if Used

9.1 Engine Oil Recommendations

Use API (American Petroleum Institute) performance class SJ engine oil or better. Also look for the SAE (Society of Automotive Engineers) viscosity grade. Referring to Fig. 11 below, choose the viscosity grade appropriate for the ambient temperatures expected until the next scheduled oil change. Single-grade SAE 30 oil is preferable when temperatures are consistently above freezing. Multi-grade oils are better when wide temperature variations are expected.

NOTE: Maintenance schedule must be followed even when using synthetic oils.

Expected Ambient Temperatures	SAE Viscosity Grade
32° F (0° C) and higher	30
10° to 100° F (-12° to 38° C)	15W-40
0° to 80° F (-18° to 27° C)	0W-30 0W-40
-20° to 50° F (-28° to 10° C)	0W-30

Fig. 11

9.2 Starting Batteries

A minimum battery rating is 450 CCA (cold cranking amps) at 0 degrees Fahrenheit for both gasoline and LP models. Ensure at least 13 volts for starting batteries.

9.3 Generator Initial Start-Up Procedure

1. Ensure that generator is filled with correct oil type.
2. 12V DC Battery connection is secured to generator.
3. Switch AC breaker(s) on generator control panel to OFF.
4. Open fuel connection and make sure switch is on the correct type of fuel desired to burn in generator.
5. Prime gasoline system using priming button (if using gasoline).
6. Press and hold Start button for 2–4 seconds.
7. If the generator does not start on the first attempt, it will automatically try 2 more starts before waiting for further input. Allow the generator to try a total of 3 starts before pressing the Start button again. It may take several attempts initially to remove air pockets and fully prime the lines with fuel to the carb.
8. Once started, allow the generator to run for 30 minutes with no load to warm up.
9. Switch breaker(s) on the generator control panel to ON.
10. Turn on appliances in the RV to load the generator with approximately 50% of the max rated watts for the generator and allow the generator to run for another 30 minutes.

If everything is running correctly and outputting power, test for recirculation as stated in exhaust Section 6.0.

10.0 Model Identification and Technical Specifications

A nameplate containing the model and serial number of the generator is affixed to the front of the generator. This information is necessary when contacting RVMP for parts, service and product information. Contact RVMP at support@rvmp.co or through www.rvmp.co.

	4,000 Watt	5,500 Watt
Model	4000i	5500i
Generator Specs	Multi-pole permanent magnet field, self-excited, 1-phase digital sine wave, air cooled	
Power (Watts)	4000 / 3800 (LP)	5500 / 5500 (LP)
Frequency	60 Hz	60 Hz
Volts	117 – 120	119 – 124
Amps	33.3	45.8
Engine Specs	1 cylinder, 4-cycle, spark ignited, OHV, air-cooled	
Bore	2.75 in (70 mm)	3.15 in (80 mm)
Stroke	2.83 in (58 mm)	2.36 in (60 mm)
Displacement	13.67 in ³ (224 cc)	18.4 in ³ (302cc)
Compression Ratio	8.8:1	9:1
Oil Capacity	1.6 qt. (1.5 liters)	1.9 qt. (1.8 liters)
Intake Valve Lash	0.00315in – 0.0472 in (0.08 mm – 0.12 mm)	0.0039 in – 0.0059 in (0.10 mm – 0.15 mm)
Exhaust Valve Lash	0.00512 in – 0.00669 in (0.13 mm – 0.17 mm)	0.0039 in – 0.0059 in (0.10 mm – 0.15 mm)
Spark Plug Gap	0.024 in – 0.0315 in (0.60 mm – 0.80 mm)	0.024 in – 0.0315 in (0.60 mm – 0.80 mm)
Ignition Timing	23° BTDC, non-adjustable	27° BTDC, non-adjustable
Governor	Digital	Digital
Choke	Automatic Digital	Automatic Digital
Oil Capacity	1.7 qt (1.6L)	1.9 qt (1.8L)
Lubrication	Splash	Splash
Emergency Start	Recoil Start Available	None

RPM	Variable 2200–3600	Variable 2600–3600
DC System Specs		
Battery Voltage	12 V	12 V
Minimum Battery Rating	450 CCA @ 0°F (-18°C)	450 CCA @ 0°F (-18°C)
Battery Cable Gauge Size	2 GA	2 GA
AC System Specs		
Design	Multi Pole PM	Multi Pole PM
AC Excitation	Brushless PM	Brushless PM
DC Excitation	Brushless PM	Brushless PM
Voltage Regulation	Digital	Digital
Voltage Regulation	117 – 120 Volts	119 – 124 Volts
Frequency Regulation	59 – 61 Hz	59 – 61 Hz
Total Harmonic Distortion	≤3%	≤3%
Ambient Temperature Rating	50°C	50°C
Neutral	Bonded	Bonded
Installation Specs		
Exhaust OD	1.13 in (28.7 mm)	1.13 in (28.7 mm)
Minimum Cooling Air Inlet Area	40 in ² (258 cm ²)	40 in ² (258 cm ²)
Unit Dimensions Excluding Hanging Frame (LxWxH inches)	29.5 X 19.25 X 13.5	29.5 X 19.25 X 13.5 in
Muffler Outlet Collar OD	1.13 in (28.7 mm)	1.13 in (28.7 mm)
Weight (with engine oil and without hanging frame)	117 lbs (53 kg)	161 lbs (73 kg)
Minimum Compartment Size	30.0 in x 19.75 in x 14.0 in (762 mm x 502 mm x 356 mm) Above floor applications	30.0 in x 19.75 in x 14.0 in (762 mm x 502 mm x 356 mm) Above floor applications
Gasoline Specs		
No Load Consumption Rate	0.12 G/hr	0.13 G/hr*
Half Load Consumption Rate	0.30 G/hr	0.30 G/hr*

Full Load Consumption Rate	0.60 G/hr	0.70 G/hr*
Fuel Connection	1/4 inch barb fitting for gasoline hoses	1/4 inch barb fitting for gasoline hoses
Propane Specs		
No Load Consumption Rate	.79 lbs/h	.90 lbs/h*
Half Load Consumption Rate	2.2 lbs/h	2.3 lbs/h*
Full Load Consumption Rate	3.3 lbs/h	3.5 lbs/h*
Fuel Connection	1/2 in – 18 UNC, SAE 45° flare fitting	1/2 in – 18 UNC, SAE 45° flare fitting
LP Vapor Supply Pressure	9–13 in (228–330 mm) WC	9–13 in (228–330 mm) WC

11.0 Warranty Info





Phone: (855) HAPPYRV

Email: support@rvmp.co

Manuals: <https://rvmp.co/manuals>

Visit rvmp.co • Copyright© 2024 RV Mobile Power, LLC. – All Rights Reserved.

Revision 4.0.9