



R V M P

flex

TEMP™



OWNER'S MANUAL

RVMP® FLEX TEMP™ On-Demand Tankless Water Heater

FG-SBMC-11 | FG-SBMC-12



For Recreational Vehicles Only



**Read this manual carefully before operation.
This manual includes important guidance for safety operation.**

Welcome to the Flex Temp™ Family	2
Safe Operation Environment	3
Safe Operating Guidelines	4
Driving Guidelines	5
Product Details	6
Performance Characteristics	9
Technical Specifications	11
Wiring Diagram	12
Exploded View	13
Installation	14
Prepare Opening	16
Prepare Propane Gas Supply Lines	18
Prepare Water Plumbing Lines	19
Prepare Electrical Wiring	20
Prepare Remote Control	21
Install Appliance	21
Check for Possible Gas Leak	24
Check for Possible Water Leak	25
Initial Startup	26
Storing Recreational Vehicle	30
Operations in Freezing Temperatures	31
Winterizing the Appliance	32
Regular Inspection	33
Hard Water Treatment	34
Error Codes	35
Troubleshooting Chart	38
Warranty	40

Welcome to the Flex Temp™ Family

Thank you for choosing the Flex Temp™ On-Demand Gas Water Heater from RVMP®. This appliance is a direct vent tankless water heater for installation in recreational vehicles only and for use with liquified petroleum gas only. This water heater has been specifically engineered for efficiency, performance, and safety. Before installing or operating your new appliance, please read this manual carefully and carefully follow all instructions and safety precautions. The manufacturer, seller, distributor, wholesaler, re-seller, and/or servicer do not accept responsibility for any damages due to the failure of anyone to observe and carefully follow the instructions and warnings in this manual and the failure to do so will void portions of the warranty.

PATENT PROTECTED - This product is protected by one or more United States Patents, please see www.rvmp.co/patents for more information on patents covering this product.

WARNING

WARNING: If the information in these instructions is not followed exactly, a fire or explosion may result causing property damage, personal injury or death.

- Installation and service must be performed by a qualified installer, service agency or the gas supplier.
- Do not attempt to install this appliance as a do-it-yourself (DIY) project.
- Read all safety rules in this manual and within cited certification guidelines before installing this appliance.
- Follow any and all state and local codes.
- Follow the regular maintenance outlined in this manual.

CAUTION

Do not store or use gasoline or other flammable vapors and liquids in the vicinity of this or any other appliance.

WHAT TO DO IF YOU SMELL GAS:

- Evacuate all persons from vehicle.
- Shut off gas supply at gas container or source.
- DO NOT touch any electrical switch, or use any phone or radio in vehicle.
- DO NOT start vehicle's engine or electric generator.
- Contact nearest gas supplier or qualified service technician for repairs.
- If you cannot reach a gas supplier or qualified service technician, contact the nearest fire department.
- DO NOT turn on gas supply until gas leak(s) has been repaired.

Safe Operation Environment

Gas combustion consumes a large amount of air and generates hot exhaust gases including carbon monoxide as the appliance works. Harm or even death may be caused by inhalation of excessive carbon monoxide. Therefore, the product must be installed and used in strict accordance with the requirements of this manual in order to achieve a safe environment. Flex Temp™ and RVMP® will not be held liable for any consequences of user's failure to install and use the appliance in accordance with the requirements of this manual.

- **NEVER** use this appliance in enclosed spaces or tents.
- **ALWAYS** turn the appliance off, and shut off fuel supply while parking the RV in an enclosed space, such as a garage or repair shop.

- **NEVER** place seating, picnic tables, awnings, or canopies in a direct path of the exhaust outlet. Note that the appliance can be installed under a RV retractable awning provided that there is no screen room or walled enclosure created with the awning.
- **NEVER** install the applicant in an area where the inlet air vent can be covered by a door when opened.
- **DO NOT** use this water heater without a working carbon monoxide detector installed in the RV. Follow the manufacturer's instructions and guidelines for its installation.
- **ALWAYS** keep the air inlet and exhaust outlet free of obstructions in order to ensure clean combustion.
- **DO NOT** place articles on or against the appliance.
- **DO NOT** lean any objects against the water heater's access door or place any foreign objects within 24" (610 mm) of the access door.
- **DO NOT** use or store flammable materials near the appliance.
- **DO NOT** spray aerosols in the vicinity of the appliance while it is in operation.
- **DO NOT** modify the appliance.

Safe Operating Guidelines

- The operator is responsible for their own health and safety, persons with pacemakers should discuss with their doctor before opening the access door, or performing any service repairs.
- The operator is responsible for the water quality used in the appliance.
- The operator is responsible for all routine inspections found in the Cleaning and Maintenance section of this manual.

- The operator is responsible for using and maintaining gas cylinders properly and/or as specified by the RV manufacturer.
- The operator is responsible for ensuring no spray water enters the appliance when cleaning the RV.
- The operator is responsible for using the appliance for potable water only. They are responsible for ensuring non-potable water sources, components, or heating systems, new or old, are not connected in any means to the appliance.

Driving Guidelines

1. The operator is responsible for ensuring all components are seated and locked in place before moving the RV, check the following: (1) Access door is flush with the mounting plate. AND (2) Door lock is engaged.
2. The operator is responsible for ensuring the gas system is turned off at the gas cylinders before transit. Turn off all necessary valves as indicated by the RV manufacturer.
3. The operator is responsible for making sure the appliance is off when refueling, traveling through tunnels, parking in garages or car ports, or on ferries.

Product Details



Front View (In black)



Rear View



Front View with Door Open



Flex Temp™ and Remote Display

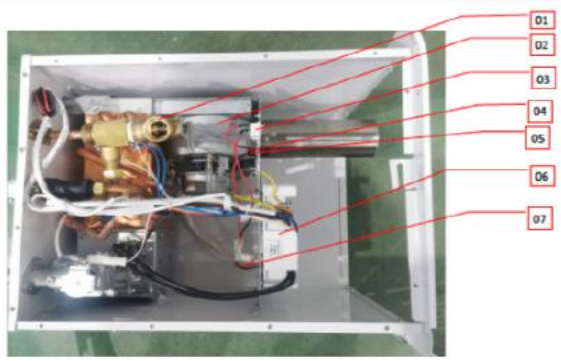

General Internal Components View

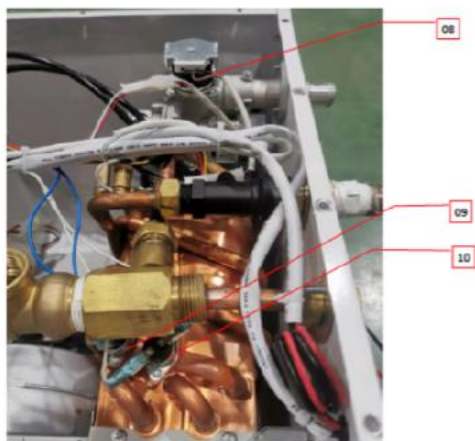

Detailed Internal View



Control Board Layout

Name	Type / Model	Technical data	
1	Pressure relief valve	J416	3/4" NPT (M) x 3/4" NPT (F)
2	Motor	KDBF105	DC 24V, R 3000r/min
3	Power Switch	KCD1	125VAC, T=125°F (125°C)
4	Fuse Holder	H3	250V,10A
5	Fuse (not show)	521	0.315-10.0A
6	Burner Control Unit	HMJD-H237	12V DC Operation temperature 14°F to 149°F (-10°C to 65°C)
7	Wire	1007	176°F (80°C), 300V
8	Combination Gas Control	PCV-10-02FD	Operation temperature -13°F to 176°F (-25°C to 80°C)
9	Temperature Limiting Thermostat	KSD301	Operation temperature 127°F (53°C)
10	Anti-freezing Thermostat	H31	250V, 10A, 41°F (5°C) operating 59°F (15°C) cutoff
11	KJ1/KJ2 (relay)	SJ-S-112DM	AC250V, 5A, T105
12	Connector on PCB	XHB-4BH	CN4, 3A
		XHB-8BH	CN7, 3A

		XHB-9BH	CN6, 3A
		VH-4BH (HX39600-4A)	CN1, 7.5A
		VH-2BH (HX39600-2A)	CN5, 7.5A
13	U4 (Main MCU)	MC96F6432Q	44 MQFP
14	PCB	KB-6160A	266°F (130°C), V-0
		ILM-R1	266°F (130°C), V-0
15	U3 (monitor MCU)	MC96F8204M	16 SOPN

Performance Characteristics

4. Microcomputer intelligent control

The CPU chip of the system automatically sets the optimal operation parameters for the appliance according to the bathing environment data such as water volume, ambient water temperature, gas pressure, and the desired hot water temperature.

- **Variable hot water temperature**

The water temperature ranges between 95°F and 123°F (35°C and 51°C).

- **Digital temperature control**

The temperature can be adjusted through a simple and intuitive user interface. The control system automatically adjusts the patented proportional valve and keeps the water temperature constant via the water temperature sensor. The microcomputer will automatically store the water temperature setting. There is no need to re-enter the desired setting when the appliance is restarted.

- **Remote LCD display**

Each unit includes an easy to operate remote LCD display control, making the efficient operation simpler and more reliable. Allows for in-coach adjustment of water temperature by the user. The appliance can display the temperature, the combustion state, the spray state, the running state of fan, the set temperature, the 20-minute countdown, the code of fault and the alarm function

- **Low-water pressure for starting**

Minimum working water pressure: 0.1 MPa (14.5 psi) (minimum water flow 0.74Gallons/min (2.8L/min)).

- **Over Pressure System**

The appliance can release pressure automatically when the water pressure exceeds the set value (0.75MPa or 109 psi), the safety valve will open, releasing the pressure.

- **Multiple protections**

The appliance has multiple protections, which include boil-dry protection, self-diagnosis of fault, safety protection device for extinguishing flame, overheating safety protection device, safety protection device for fan fault, electric leakage safety protection device, protection device for excessive air pressure, automatic pressure relief valve for excessive water pressure, antifreeze device, protection device for gas leakage.

Technical Specifications

Models		FG-SBMC-11 / FG-SBMC-12
Rated heat load		55,000 BTU
Starting heat load		60,000 BTU
Rated operating heat range		19,000 - 55,000 BTU
Rated water production capacity		2.11 Gallons/min (8kg/min)
Exhaust mode		Forced exhaust
Control mode		Water control system
Ignition mode		Pulse electronic ignition
Applicable water pressure		14.5 psi - 109 psi (0.1MPa - 0.75MPa)
Minimum flow for starting		0.74Gallons/min (2.8L/min)
Rated voltage		DC 12V
Rated LP gas pressure		0.41 psi (2.80kPa)
Unit size		16.93" x 12.6" x 12.6" (430 x 320 x 320 mm)
Net weight		24lb (10.9 kg)
Exhaust pipe specification		Schedule 60
Rated power consumption		36W
Specification of fittings	Water inlet fitting specification	½" Female NPT
	Water outlet fitting	½" Female NPT
	Gas (LP) fitting specification	⅜" or ⅝" Male Flare

Wiring Diagram

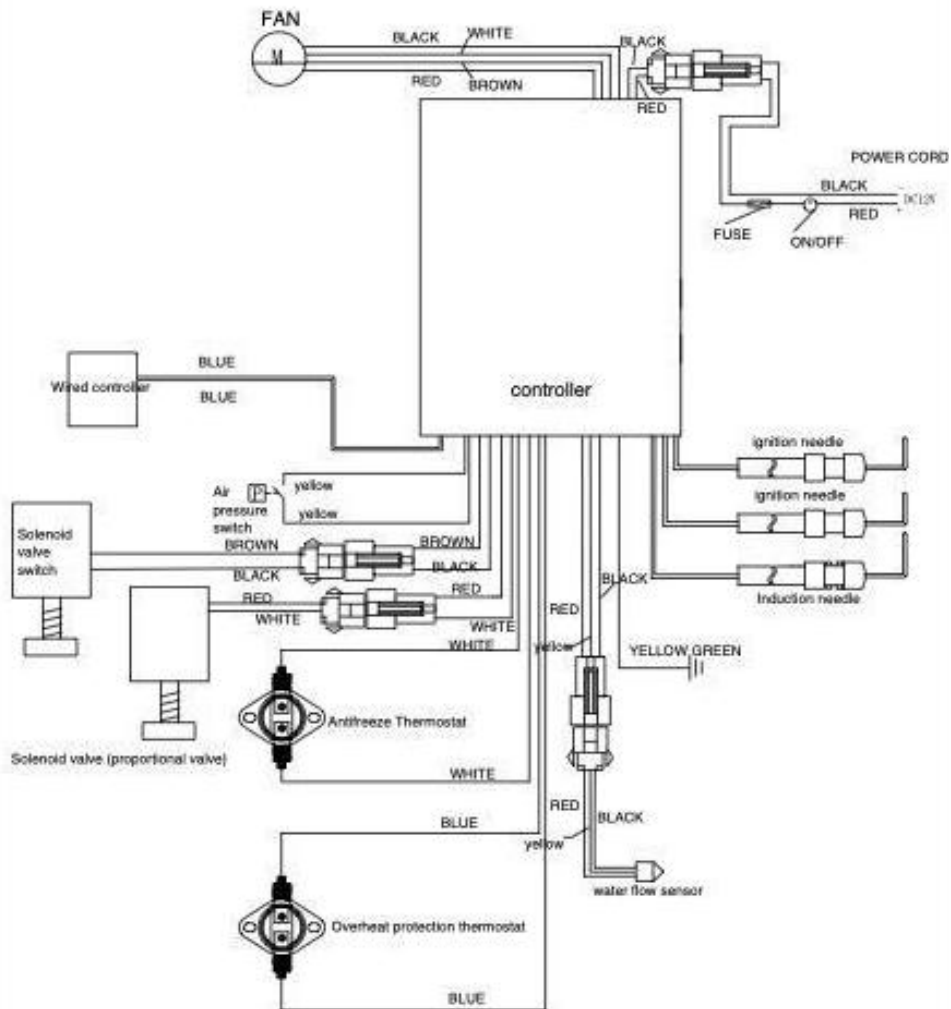

Exploded View

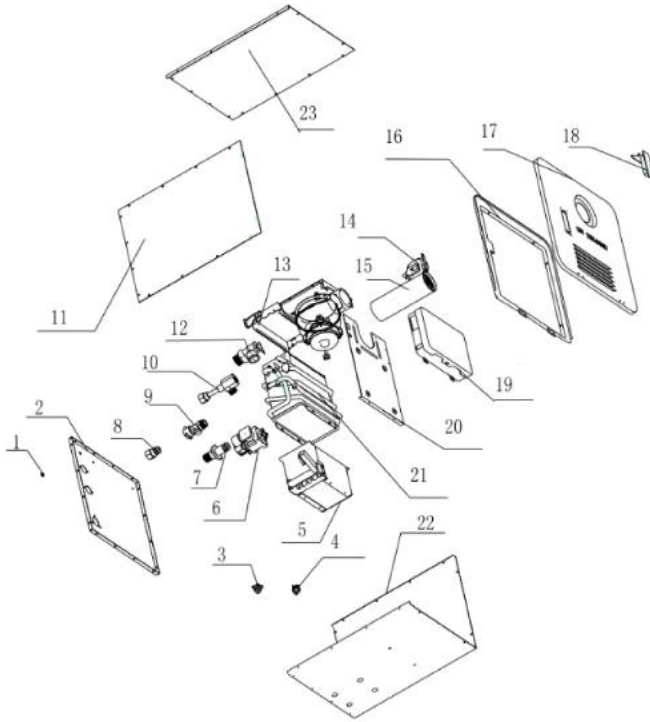

1	Guard Coil	13	Fan
2	Body Shell 2	14	Wind Pressure Switch
3	Antifreeze Thermostat	15	Smoke Tube
4	Overheat Protection Thermostat	16	Door Frame
5	Burner	17	Door
6	Proportional Valve	18	Lock
7	Gas Inlet Connector	19	Controller
8	Water Inlet Connector	20	Bracket

1	Guard Coil	13	Fan
2	Body Shell 2	14	Wind Pressure Switch
3	Antifreeze Thermostat	15	Smoke Tube
4	Overheat Protection Thermostat	16	Door Frame
5	Burner	17	Door
6	Proportional Valve	18	Lock
7	Gas Inlet Connector	19	Controller
9	Water Flow Sensor	21	Heat Exchanger
10	Pressure Relief Valve Adapter Set	22	Body Shell 1
11	Body Shell 5	23	Body Shell 1
12	Pressure Relief Valve		

Installation

DANGER

WARNING: Suffocation and/or Fire Hazard

Observe all installation material in accordance with governing codes and ordinances.

Failure to follow all instructions will result in serious injury, property damage, or death.

The installation of this appliance, along with all subsequent components to support installation and operation of the appliance, must conform with country, state and local codes. In the absence of such codes, refer to the latest editions of:

- **USA:**

- ANSI A119.5 - Recreational Vehicles (RV)– NFPA 1192 - Park Model RV
- ANSI/RVIA LV - Low Voltage Standard– NFPA 70 - National Electric Code
- ANSI Z223.1 - National Fuel Gas Code - NFPA 54

- **Canada:**

- CSA Z240 RV Series - Recreational Vehicles
- CSA Z241 - Park Model RV
- CSA C22.1 - Canadian Electric Code
- CSA B149.1 - National Gas and Propane Installation Code

CAUTION

CAUTION: Always wear protective gear such as gloves, eyewear and clothing to avoid injuries during installation and servicing of the product.

- **For Recreational Vehicle (RV) installation only**

NOTE: This water heater is certified ANSI Z 21.10.3 /CSA4.3-2017 for installation in Recreational Vehicles (RV) and is not for use in Marine or Space Heating Applications. RV's are recreation vehicles, having their own power or towed by another vehicle, designed as temporary living quarters for recreation, camping, or travel use.

- Any Installation must be performed by a qualified person, in accordance with this instruction manual.
- **DO NOT** use test pressures higher than 40in-wc (1.45PSI) to test the gas leaks.
- **DO NOT** attempt to modify the appliance.
- **DO NOT** alter the appliance for a positive grounding battery system.
- **DO NOT** move the appliance by grabbing the interior components.
- Make sure all exhaust gases are directed outside the RV.
- Protect all combustible material from the exhaust gases.
- **DO NOT** draw air for combustion from occupied spaces.

- Always disconnect the 12V appliance (to protect the control from surges that may occur) when performing Dielectric (hi-pot) testing, welding, electrical, etc... work on the coach.

Prepare Opening

01. **Choose a location to place the appliance, based on the following criteria:**
- DO NOT** install on the rear or front of the RV to minimize contamination from road grime, debris and wet roads when traveling.
 - DO NOT** install the appliance in an outdoor enclosed area.
 - DO NOT** install the appliance in any location where the exhaust vent may be covered or obstructed when a swing door, bag door, slide out, pop up, etc. is partially or fully extended.
 - DO NOT** install this appliance on any door or slide out area.
 - DO NOT** install the appliance where the access door is less than:
 - 9" (229mm) from any opening into the vehicle
 - 36" (914) from any motor driven air intake
 - 36" (914mm) from the any gas tank connection or ventilation.
- NOTE:** These are guidelines, refer to NFP1192, Z240 RV edition for specific requirements.
- Choose a convenient location where supply water, LP gas, and 12V DC is accessible to the back side of the appliance for installation and servicing.
 - The water heater is designed to be installed on a flat floor (made of Wood or Linoleum) or a fixed platform.

- h. It is recommended that the appliance be located in a central location to the hot water loads.
- i. Ensure that a clearance of at least one inch will remain after installation between the top surface of the appliance and any combustible material.
- j. NOTE: To install on a carpeted area, a metal or wood panel that extends at least 3 inches beyond the width and depth of the water heater is required to install under the unit.
- k. If water leakage would damage the adjacent area to the installation, a drain pan should be installed that will drain to the exterior of the RV.
- l. Create a cutout with the dimensions (shown in inches) below, preferably with square corners.

02. Create a cutout with the dimensions (shown in inches) below, preferably with square corners.

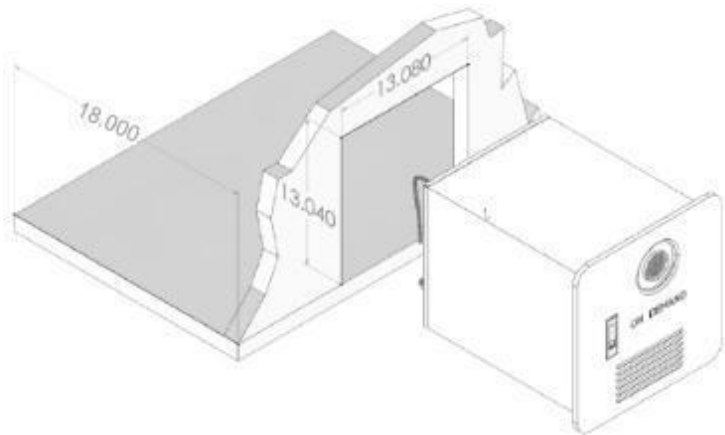

- a. Dimensions for cutout are: 13.040" h x 13.080" w x 18" of clear space at rear of unit. (See drawing above)
- b. Ensure that the front edge of the opening is surrounded by a solid frame which can accept anchors for securing the appliance. If necessary, reinforce the opening with 1.5" x 1.5" or 2" x 2" framing.
- c. Ensure that the appliance is supported by a solid floor or platform with enough weight bearing capacity. If necessary, construct a platform or base to support the appliance.

- d. Leave adequate room at the rear of the appliance for connection of gas, water, and electrical connections.

Prepare Propane Gas Supply Lines

DANGER

WARNING: Fire or Explosion Hazard

Follow all applicable codes, regulations and instruction material when performing any install or service work.

Failure to follow instruction will result in product damage, serious injury or death.

Fuel entering the appliance must be in gas phase, liquid phase must not be used and will result in damage to the product.

- This appliance is rated for 55,000 BTU/HR, 11~14in-wc. (27.4~34.9mbar). Follow NFPA1192 and Z240 RV series for proper pipe sizing based on additional gas burning appliance loads.
- Use with LP gas (propane) only. Butane or any mixtures containing more than 10% butane must not be used.
- The gas line must terminate with a 3/8" NPT female fitting to connect with the male fitting at the inlet of the appliance.
- A non Metallic Flexible gas hose must be rated for 149°F (65°C). Anchor appropriately to prevent fatigue and failure from wear edges.
- Make sure that the operating pressure of the gas supply corresponds to the operating pressure of the appliance 11~14in-wc (27.4~34.9mbar).

01. Locate entry point for the plumbing to service the rear of the appliance. Ensure entry point is not in the footprint space of the appliance.
02. Feed propane line into proximity of the appliance install location, leave enough length to flex into position so that when connected no kinks are

created.

NOTE: An approved semi-flexible metallic pipe is acceptable to connect as an extension from the propane line to the appliance.

Prepare Water Plumbing Lines

- The plumbing must be rated to supply between 35-70PSI nominal.
 - Water connections can be made using PEX swivel nut adapters with NPT straight threads and a cone seal or with standard 1/2" NPT fittings.
 - For proper operation this water heater requires a minimum water flow of 0.74 Gallons per Minute (Gal/min) or 2.8 Liters per Minute (L/min).
01. Locate entry point for the plumbing to service the rear of the appliance. Ensure entry point is not in the footprint space of the appliance.
 02. Create a piping layout to supply the appliance with cold water inlet and hot water outlet.

NOTE: Dry fit tubing and fittings before clamping together. Adjust sections to avoid excessive stress on the fittings when assembled to the appliance. It may be helpful to fit the appliance into position to determine the appropriate piping layout.

Prepare Electrical Wiring

WARNING

WARNING: Electrical Shock Hazard

- Disconnect all power before performing any work.
 - Always use a certified and proven 12V isolated power supply, that is properly grounded to the RV.
 - Follow all applicable codes, regulations and instruction material when performing service work.
-

Failure to follow instruction could result in serious injury or death.

01. Disconnect all power before performing any work.

- a. Wiring connected to or in proximity of the appliance must be rated for 140°F (60°C) minimum.
- b. Use only insulated terminals for all electrical connections. The appliance requires a power source that can adequately provide 10~17V DC to function properly. Contact RVMP for available Power centers, converters and distribution panels.
- c. Select a distribution branch greater than 3A, preferably 15 amp, to provide nominal 12V to the appliance from the distribution panel.

NOTE: The appliance has a built in fuse, serviceable from the front of the product. The appliance can be on a dedicated or shared branch circuit with the same or higher rating.

Optional: A power switch can be placed in the living quarters for

convenience, but not required as a switch is located externally on the appliance. If the switch is fused, make sure it is rated for at least 3A.

02. Locate an entry point for the wiring to service the rear of the appliance. Ensure entry point is not in the footprint space of the appliance. Make sure any housing or encasement edges are protected to prevent wire abrasion from occurring.
03. Determine the appropriate wire gauge (AWG) for the 12V power supply length. Ensure enough wire is available to make adequate connection.
 - 16AWG max. 40 feet (12m)
 - 14AWG max. 66 feet (20m)
04. Feed wire from power source to the entry point. Make a suitable connection to the power source.

Prepare Remote Control

01. Determine a location to install the wall remote control within the interior of the RV.
02. Drill a 3/4" hole and clean the edges.
03. If necessary, run two electrical wires that extend the wall control connections (blue wires) to the appliance connections (blue wires) using the appropriate wire size. 16AWG max. 65ft (20m).

Install Appliance

01. Remove the appliance from its packaging.
02. Remove protective caps for COLD (blue) and HOT (red) water along with any caps for the gas inlet.

03. Open the front access door.

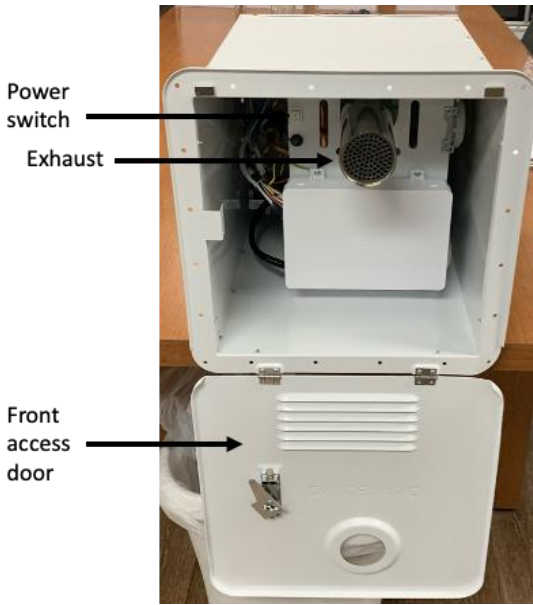

04. Position the appliance into the frame opening.

05. Ensure that the electrical power switch on the front of the appliance is set to the OFF position.

06. Ensure that the gas supply is turned OFF.

07. Connect the gas service line to the gas inlet on the back of the appliance using either the $\frac{5}{8}$ " male flare connection or the included adapter which reduces this to $\frac{3}{8}$ " male flare connection. **DO NOT** overtighten.

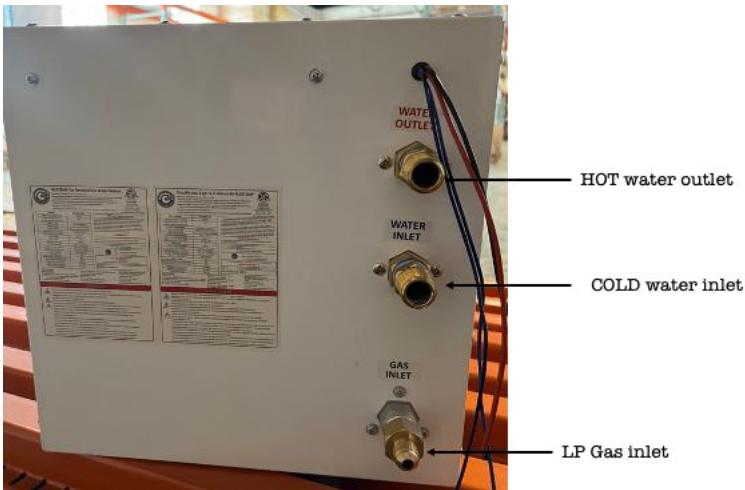

08. Connect the power supply wires (red and black wires on rear of water heater) to the appropriate nominal 12V DC power source connection.

NOTE: The red wire is positive (+) and the black wire is negative (-).

09. Connect the wall controller wires (2 blue wires on the appliance).

NOTE: Polarity does not matter, the wires can be connected to either blue wires.

10. Connect the HOT and COLD water lines to the appropriate connections on the back of the appliance using $\frac{1}{2}$ " NPT connections. **DO NOT** overtighten.
11. Apply adequate amounts of water sealing material (ex. butyl tape 1 inch wide, not included) around the entire backside of the front flange and any holes. **DO NOT** use adhesive sealing material (ex. silicone) for the watertight

seal.

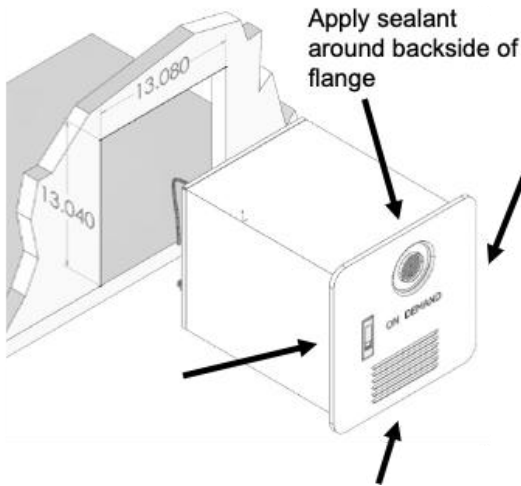

12. Slide appliance through the cutout fully until the front flange is contacting the RV sidewall.
13. Secure the flange to the sidewall using fasteners, preferably stainless steel or corrosion resistant.
14. Apply any additional amount of water sealant around the flange and perimeter of the front of the appliance. Close the front access door.

Check for Possible Gas Leak

⚠ WARNING

WARNING: Fire and Explosion Hazard

- Ensure test pressures are below 40in-wc (100mbar).
- DO NOT use matches, candles or other sources of ignition when checking for gas leaks.
- Use a gas leak detection liquid or equivalent.

- Make certain to re-test all fittings after making adjustments to loose connections.

Failure to follow instruction may lead to serious injury, property damage or death.

01. Verify the electric power switch on the water heater is in the “OFF” position.
02. Turn on the gas supply or alternative pressure supply.
03. Check the appliance and all gas connections for gas leaks with leak detection liquid (not provided) or an equivalent gas leak detection method. Bubbles indicate a gas leak that must be repaired.
04. Repair gas leaks as needed.
05. Repeat gas leak check after any adjustments to loose connections.

NOTE: After leak checking, make sure the gas supply pressure corresponds to the operating pressure of the appliance 11~14in-wc (27.4~34.9mbar).

Check for Possible Water Leak

01. Verify the electric power switch on the water heater is in the “OFF” position.
02. Turn on the water supply to the unit
03. Open water faucets to fill the system with water.
04. Close the faucets when the water is flowing smoothly and all air is removed from the lines.
05. Check all connections for water leaks by eye and touch.
06. Repair any leaks as needed.

Initial Startup

WARNING

Ensure all necessary system leak tests are complete before performing any functional test. Failure to follow instructions could lead to serious injury, property damage or death.

01. Verify the power switch is in the “OFF” position.
02. Confirm that there is a “steady” water flow (not pulsating) and no air in the system. If supply is pulsating, adjust water pump settings.
03. Ensure that all valves which mix cold and hot water are shut. NOTE: Outside faucets with detachable spigots and shower heads with flow interrupters can bleed hot water into the cold side if the valves are not closed properly. This will hinder the performance of the water heater.
04. Turn the electric power switch on the front of the appliance to the ON position and verify that the remote control unit illuminates. If the remote control unit does not illuminate, press the Power button on the remote control unit. When the remote control powers up, you should hear a single BEEP.
05. The remote control is shown below, where each button’s functionality is indicated. After the initial start up, the display will show the ambient water temperature (the temperature of the water inside the appliance) as a steady indicator (i.e. the numbers are not flashing). To switch between Celsius and Fahrenheit units for the temperature display, simply press the Metric/US button.

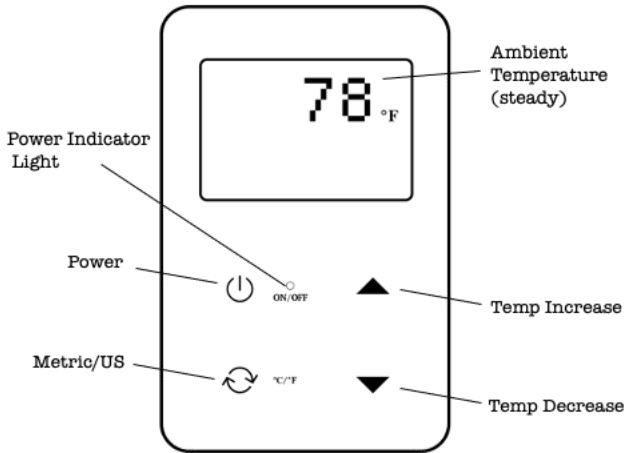

06. To select a desired hot water temperature setting, simply press the Temp Increase and/or Temp Decrease button until the desired temperature setting is displayed. The remote will emit a single BEEP each time the temperature is changed. The desired temperature setting is the temperature of the water exiting the appliance, while the actual temperature can be somewhat less and would likely be mixed with some cold water.
07. Note that this desired temperature setting is shown as a flashing indicator for several seconds after the Increase/Decrease button is pushed. This is in contrast to the ambient temperature described above, where the number is steady and not flashing. After a few seconds of flashing the desired temperature, the remote will return to showing the ambient temperature, indicated by the steady display and no more flashing.
08. Below is an illustration of a remote panel once the Increase/Decrease button(s) have been pushed to select 113° F as the desired hot water temperature. This desired temperature value is shown flashing for several seconds, before returning to display the ambient temperature. Also note that the display is also showing the Fan Indicator, which is a graphic that is displayed to indicate that the fan inside the appliance is running. The fan will run before, during, and after the gas burner is ignited.

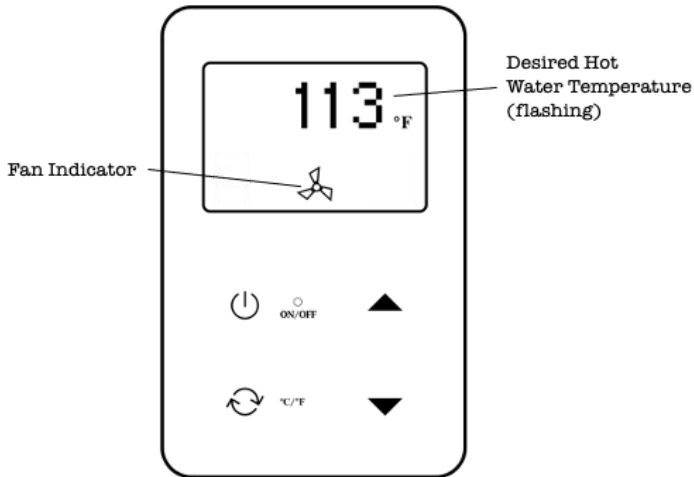

09. Turn on the gas supply. You should not hear the burner inside the appliance start up yet, as the burner in the appliance will not ignite until water begins flowing.
10. Fully open a hot water faucet and verify that you can hear ignition from the burner and that (after a few seconds) hot water is supplied at the faucet. Ensure that the faucet is opened fully and not just partially, as the burner will not kick on until there is adequate water flow. So do not open the faucet for only a 'trickle' of hot water as this will not be enough flow for the burner to ignite and the water will remain cold.
11. Below is an illustration of a remote panel where the faucet has been opened and water is flowing (indicated by the Water Flow Indicator) and the burner is active (indicated by the Burner On Indicator).

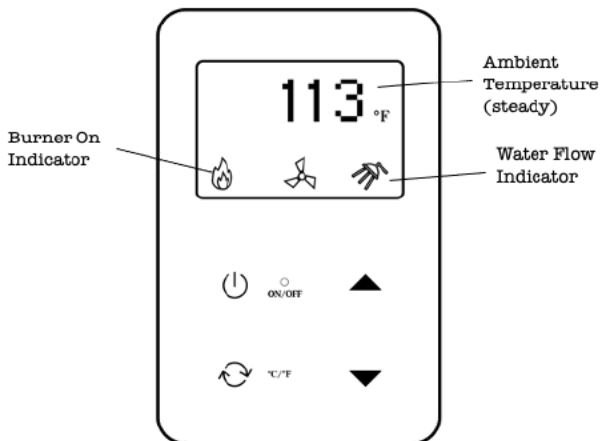

12. Once the hot water faucet is turned off, the appliance will sense that the water flow has stopped and will turn off the gas burner but will allow the fan to continue running to cool the interior of the appliance and continue exhausting. Below is an illustration of a remote panel where the faucet has been closed and water is no longer flowing. Note that after running the unit for a few minutes, the ambient temperature is now approximately equal to the desired temperature setting.

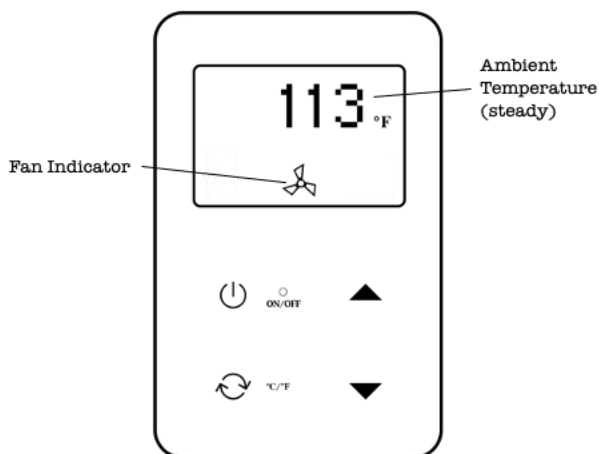

13. The fan will then stop, and the remote display will return to simply showing the ambient temperature.

CAUTION

CAUTION: Exhaust gases will be hot, always avoid the area around the exhaust when running the appliance.



NOTE FOR SCALD: When taking a shower or using hot water, please test the water temperature before use to avoid being scalded.

Storing Recreational Vehicle

Anytime the RV is not intended to be used, it is considered to be in storage or transit.

To prepare the water heater for storage, follow the steps below:

01. Turn off gas supply.
02. Turn off the electric power switch.

If freezing/frost conditions will occur (ambient temperature less than 39°F (4°C)) you must either a) remove all water from the water heater and optionally install RV non-toxic antifreeze, or b) utilize the water heater's automated warming system by leaving the gas supply on as well as the electric power switch (Note that the power and the gas supply MUST remain ON for this feature to be used). These are described in detail below.

Operations in Freezing Temperatures

This water heater is equipped with an automated warming system for use in cold weather conditions. The purpose of this system is to keep the water heater from freezing when the RV is used in conditions where the ambient air is near the freezing temperature of water, and thus prevents water in the unit from freezing. There is a bi-metallic cold weather thermostat located on the hot water line. This cold weather thermostat is designed to turn on the burner at 35°F and turn off the burner at 48°F. The control board will keep the burner on until the thermostat turns off when the temperature on the water line reaches 48°F.

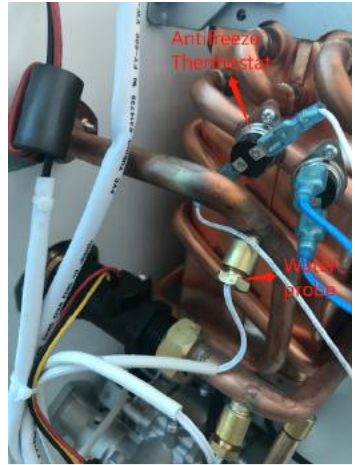

At this point the flame should turn off immediately and the fan will turn off 30 seconds later. When the system operates with the warming system an “Fd” code will show on the UCP. Fd: Warming cold weather thermostat has engaged and turned on the burner of the water heater.

⚠ WARNING

WARNING: Automated warming system requires both electrical power and lp supply to function.

To utilize the automated warming system the water heater must be powered and must have LP supply open, so do not turn off power to your water heater or the LP supply if you want to use the automated warming system. If you are winterizing your RV and plan to turn off power and LP supply, you will need to use the techniques below to winterize your water heater (if the RV will experience freezing/frost temperatures).

Winterizing the Appliance

CAUTION

CAUTION: Product damage due to frost condition.

In frost conditions, ambient temperatures below 39°F (4°C), there is a risk that water in pipes, faucets and the appliance could freeze. This can cause considerable damage. Be sure to remove all water and optionally apply RV grade non-toxic antifreeze.

Follow the instructions provided by the RV coach manufacturer for winterizing your water system.

Supplement the following important water heater instructions when completing any winterizing steps:

01. **Compressed Air:**

- a. DO NOT exceed 30PSI into the RV water system or water heater.
- b. Ideally, all water should be removed out of the entire RV water system. To complete this, Inject compressed air into the water supply for the RV and open each faucet (sink, shower, outdoor faucet, etc.) to allow the water in the system to drain out. A combination of different faucets should be opened/closed to ensure that each line in the system receives maximum air pressure and each supply line to the RV is completely evacuated.
- c. After removing the bulk of the water in the lines, while completing the blow out process for the entire water system, take time to isolate the water heater and inject the compressed air directly into the cold water inlet on the water heater. This ensures maximum pressure and flow is isolated through the water heater for complete evacuation.

02. **AntiFreeze (Optional but recommended):**

- a. Use a non-toxic antifreeze recommended by the RV coach manufacturer and apply as prescribed on the antifreeze instructions.
- b. Antifreeze can be used directly in the water heater, plan for an additional 1L to fill the system.

Optional: A bypass valve can be installed/used to bypass filling the water heater with antifreeze. The water heater **MUST** be evacuated with compressed air (see steps above) before bypassing.

03. **Next Season:**

- a. Thoroughly flush the water heater and system with clean drinking water through the hot and cold side before using. Sanitize the water system per the recommendations of your coach manufacturer.

Regular Inspection

Regular inspection is critical for maintaining proper operation of your appliance. Unless specified, review the following items yearly or before each season:

01. Inspect the gas system and installation every two years, or otherwise specified by your RV coach manufacturer, by a qualified personnel. Inspect for cracks, separation, peeling of seals to the RV wall. Remove and re-seal as necessary (caulking or tape) between the side wall and the door of the water heater and ensure that the unit is solidly mounted to the vehicle.
02. Verify that the air inlet openings (louvers) are completely open and clear of any debris including mud, leaves, twigs, insects, etc... Remove all obstructions to allow full air flow.
03. Insects, including wasps and spiders, can build nests in the exhaust tube outlet which will affect the performance of the unit. Inspect the flue outlet tube to make sure that it is unobstructed and that the screen is clean. If debris or insects are present, clean and vacuum to remove any remaining debris. The use of any type of after-market screen to cover the vent is not permitted and will void the warranty.

04. Open the door and verify that no debris or extraneous or combustible materials are present anywhere near the burner. Remove any item that is present and wipe clean the bottom of the housing.
05. Inspect the interior surface of the housing for any cracks or corroded areas that could allow penetration of gases into or out of the interior of the vehicle. Check especially around the hot water, cold water, gas and electrical connections. If any damage is found, please contact a technician to schedule a repair or contact Flex Temp customer service.
06. Check that all wire connections are firmly in place and there are no signs of chafing or cracks on the insulation. Verify that the spark ignition cable between the control board and the igniter is securely in place and not shorted to any metal component.
07. Inspect the pressure safety valve to ensure it has not been leaking (no water residue).
08. Inspect/clean/replace water inlet filter as necessary.

Hard Water Treatment

Prolonged usage with hard inlet water can result in buildup in the appliance and eventual damage or failure.

When exposed to higher water hardness concentrations, it is advised to provide a proper water treatment device for the incoming water to the coach. Hard water may lead to performance reduction of your appliance overtime.

Contact RVMP for decalcification instructions (support@rvmp.co).

Error Codes

If the appliance malfunctions, a beep alarm will sound and an error code will display on the remote controller. Write down the error code, then try resolving by stopping and restarting the water flow, or resetting the appliance as follows:

01. Switch the electric power switch on the front of the water heater to the “OFF” position.
02. Wait 5 seconds.
03. Switch the appliance ON again. Determine if error code is removed.

Continue to use the appliance normally. If an error fault code continues to display, review the following table for potential causes.

Code	Possible Causes	Solutions
E0	<p>Error in the outlet water temperature sensor.</p> <ol style="list-style-type: none">1. Sensor could be disconnected, or the connection is loose or having poor contact.2. Open circuit or short circuit from a sensor touching the housing.3. Circuit board malfunction of the controls for the temperature sensor.	<ol style="list-style-type: none">1. Inspect the connector and wiring. Replace connector or wiring if damaged or loose.2. Replace the temperature sensor.3. Replace the circuit board or repair the relevant control circuit.
E1	<p>Failure to ignite or Accidental flame out.</p> <ol style="list-style-type: none">1. Propane tank is empty.2. Low gas inlet pressure.3. Flame sensor is disconnected, or the connection is loose or poor contact.4. Bad flame sensor.	<ol style="list-style-type: none">1. Re-fill propane / Replace with new tank.2. Check propane regulator pressure to ensure it meets the minimum pressure requirements.

	<p>5. Dirt or obstructions within igniter area.</p>	<p>3. Inspect flame sensor and electrical connections, repair or replace.</p> <p>4. Replace flame sensor.</p> <p>5. Remove/clean all dirt and obstructions from the igniter area.</p>
<p>E2</p>	<p>A flame signal was detected prior to the start of the ignition process.</p> <ul style="list-style-type: none"> ● Flame sensor is disconnected, or the connection is loose or poor contact. ● Bad flame sensor. ● Dirt or obstructions within igniter area. ● Bad circuit board controller. 	<p>1. Inspect flame sensor and electrical connections, repair or replace.</p> <p>2. Replace flame sensor.</p> <p>3. Removed/clean all dirt and obstructions from the igniter area.</p> <p>4. Replace circuit board controller.</p>
<p>E3</p>	<p>Possible thermostat failure, where water above the max temperature is being measured.</p> <ol style="list-style-type: none"> 1. Failure in thermostat controls. 2. Water supply pressure is too low. 	<p>1. Replace control board.</p> <p>2. Check water supply pressure and that it exceeds the minimum required water supply pressure for the unit. Remove anything that limits or restricts available water pressure.</p>
<p>E4</p>	<p>Possible inlet temperature probe failure.</p> <p>Inlet temperature probe is disconnected, or the connection is loose or poor contact.</p> <ol style="list-style-type: none"> 1. Bad inlet temperature probe. 2. Bad circuit board controller. 	<p>1. Inspect inlet temperature probe and electrical connections, repair or replace.</p> <p>2. Replace inlet temperature probe.</p> <p>3. Replace circuit board controller.</p>

E5	<p>Possible fan or airflow failure.</p> <ol style="list-style-type: none"> 1. Bad fan or damaged fan. 2. Debris blocking airflow 3. Bad power supply to the fan. 4. Bad electrical connections to the fan. 	<ol style="list-style-type: none"> 1. Replace fan. 2. Remove debris blocking airflow. 3. Replace fan power supply. 4. Inspect fan wiring for loose connections and replace fan electrical connections if necessary.
E6	<p>Outlet water too hot / Overheat failure after 3+ seconds of water temperature higher than maximum.</p> <ol style="list-style-type: none"> 1. Inlet water pressure too low. 	<ol style="list-style-type: none"> 1. Check water supply pressure and that it exceeds the minimum required water supply pressure for the unit. Remove anything that limits or restricts available water pressure.
E7	<p>Possible failure with gas inlet valve. Before or during normal combustion process, an open condition or short in the valve is detected.</p> <ol style="list-style-type: none"> 1. Bad electrical connections to gas valve. 2. Bad gas valve. 	<ol style="list-style-type: none"> 1. Inspect and repair or replace damaged electrical connections with gas valve. 2. Replace gas valve.
E8	<p>Possible air pressure switch failure. Air pressure switch is closed or disconnected.</p> <ol style="list-style-type: none"> 1. Fan speed is over the limit. 2. Debris could be blocking airflow. 3. Bad electrical connections to air pressure switch. 4. Bad air pressure switch. 	<ol style="list-style-type: none"> 1. Check fan to ensure good electrical connections, power supply, and is functioning properly. 2. Remove any debris blocking airflow. 3. Inspect and repair or replace electrical connections to air pressure switch. 4. Replace air pressure switch.

E9	Flame sensor is sensing a flame prior to ignition of combustion process. 1. Likely a bad flame sensor or short.	1. Replace flame sensor.
En	Timeout function	Water heater operated longer than pre-set time limitations. Normal protections. Simply turn the appliance OFF and then back ON.
Fd	Cold Weather AntiFreeze Operations	System is firing the burner to prevent freezing of any water in the system. Burners will run until safe warmer temperature is reached. Normal operations.

Troubleshooting Chart

Problem	Possible Causes	Solutions
Hot water faucet is turned ON, but there is no hot water	The gas valve and/or water inlet valve are closed.	Open the gas valve and water inlet valve.

coming out.

	Water supply has been interrupted.	Retry once water supply is adequately restored.
	Hot water faucet is not open completely.	Open hot water faucet completely to ensure adequate water flow.
	Appliance is frozen.	Allow appliance to thaw and retry.
	Malfunction in control board.	Check for any fault or error codes and address the issue per the error code table herein.
	Propane is empty or low.	Refill propane supply and retry.
Water does not increase in temperature when the temperature setting is increased on the controls.	The gas valve and/or water inlet valve are not completely open.	Make sure these valves are completely open.
	The set temperature exceeds heating capability with low inlet water temperatures.	Reduce temperature setting to one that can be maintained given the conditions.
	Water flow is too high.	Reduce water demand/flow by turning off a hot water faucet or

		partially closing a valve.
Hot water faucet is slightly open, but the water coming out is not hot.	The appliance will turn off when minimum flow rate is reached. 2.8 L/min (0.74 Gallons/min).	Open the hot water faucet further to increase the flow rate of water beyond minimum so that the appliance turns on.
Hot water does not flow immediately when the faucet is opened.	It will take a moment for the appliance to initiate combustion and then for cold water in the water lines to be removed.	Simply wait for the hot water to come from the appliance to the location of the hot water faucet.
The hot water dispensed is white and cloudy.	This is from tiny bubbles which develop from air that is present in the water while being rapidly heated.	This is normal.
White smoke is exhausted from the exhaust of the appliance in cold weather.	The water vapor that is present within the exhaust gas will appear white in cold ambient air.	This is normal.
The fan continues to run even though the appliance has stopped.	The fan will continue to run for 10-20 seconds even once water stops flowing.	This is normal.

Warranty

Flex Temp™ Limited Warranty (North American Consumer Sales)

This Limited Warranty ("Warranty") outlines applicable coverage and claims procedures for Products, as defined herein, sold as Flex Temp™ Aftermarket Division which is referenced herein as "Warrantor", "we", "us" or "our".

Coverage. Subject to the following terms and conditions, we warrant ONLY to you as the original consumer ("you" or "your") who purchases the product directly from Flex Temp™ Facility or authorized Flex Temp™ Dealer, that the products that we manufacture, distribute and/or sell to you that are not already covered by a separate written warranty from another manufacturer (the "Product(s)") will be free from defects in materials and workmanship at the time of retail sale. We will honor this Warranty for a period of one (1) year from the date of retail purchase, and only for Products sold and used in the United States and Canada.

Service. For Products having a covered defect within the Warranty period, we will, in our sole and absolute discretion, repair or replace the Product or related component with a new or refurbished component or provide a pro rata refund of that portion of the Product. Labor will be allowed if a designated flat rate time is outlined by us and will be limited to the published flat rate amount. There is no other warranty.

Notice. Proof of purchase must be provided to us to be eligible for coverage. No remedy will be required or offered unless we receive written notice of a claimed defect. You must make any claim of defect, including without limitation under this Warranty, in writing, with full particulars, promptly after the defect was or reasonably should have been discovered, and in any event no later than thirty (30) days of its discovery. Your written notice must describe the defect, provide your name and address, and state the location of the Product. As a condition of coverage, we must be provided access to the original Product for inspection, testing, or other work at our discretion. The Product must remain unmodified. We will not consider any claims for Products (or any components thereof) that are not in their original form. Failure to give us proper notice of a claimed defect, or performing any modification, replacement, attempted repair, self-help, or alteration of the Product or other product into which our Product has been incorporated without our prior written approval and before we inspect or test the Product, will constitute an absolute waiver and release of all claims under this Warranty.

Transferability. THIS WARRANTY IS NOT ASSIGNABLE OR TRANSFERABLE. THIS WARRANTY EXTENDS ONLY TO YOU, THE ORIGINAL CONSUMER PURCHASING A PRODUCT DIRECTLY FROM WARRANTOR'S FACILITIES AND WILL NOT BE CONSTRUED TO EXTEND TO ANY THIRD-PARTY. THERE ARE NO THIRD-PARTY BENEFICIARIES TO THE WARRANTY'S TERMS.

Limitations. ANY IMPLIED WARRANTY THAT MAY ARISE BY LAW IS LIMITED IN DURATION TO THE TERM HEREIN AND TO THE COVERED PRODUCTS. THE REPAIR, REPLACEMENT, OR REFUND PROVIDED HEREIN IS EXCLUSIVE AND IN LIEU OF ALL OTHER REMEDIES. EXCEPT AS PROVIDED IN THIS WARRANTY, ALL PRODUCTS ARE BEING SOLD "AS IS" AND "WITH ALL FAULTS." ALL RISKS AS TO PRODUCT QUALITY OR PERFORMANCE NOT CONTEMPLATED BY THIS WARRANTY WILL BE BORNE EXCLUSIVELY BY YOU, THE PURCHASER. IF A PRODUCT PROVES DEFECTIVE AFTER ITS PURCHASE, YOU, NOT US, ASSUME THE ENTIRE COST OF ALL NECESSARY SERVICING OR REPAIR THAT IS NOT COVERED UNDER THIS WARRANTY. IN NO EVENT WILL WE BE LIABLE FOR COSTS OF REMOVAL OR REINSTALLATION OF THE PRODUCTS, OR ANY EXPENSE RELATED TO REINSTALLATION. WE WILL HAVE NO LIABILITY TO ANYONE FOR CONSEQUENTIAL, SPECIAL, INCIDENTAL, INDIRECT, EXEMPLARY, OR PUNITIVE DAMAGES OF ANY KIND WHATSOEVER, INCLUDING WITHOUT LIMITATION PROPERTY DAMAGE, LOST PROFITS, LABOR COSTS, OR ANY OTHER PECUNIARY DAMAGE, WHETHER DUE TO ANY DEFECT IN THE PRODUCTS, BREACH, DELAY, NON-DELIVERY, NON-PERFORMANCE, RECALL, OR ANY OTHER REASON. ALL CLAIMS FOR NEGLIGENCE AND FOR FAILURE OF ESSENTIAL PURPOSE ARE EXPRESSLY WAIVED AND RELEASED. UNDER NO CIRCUMSTANCES WILL OUR LIABILITY FOR ANY DEFECT IN THE GOODS, WHETHER BASED ON CONTRACT, TORT, WARRANTY, OR ANY OTHER THEORY, EXCEED THE PURCHASE PRICE OF THE PRODUCTS. YOU ACKNOWLEDGE AND DECLARE THAT THESE LIMITATIONS AND WAIVERS HAVE BEEN BROUGHT TO YOUR ATTENTION AND EXPLAINED, THAT YOU HAVE READ AND UNDERSTAND ALL TERMS AND AGREE TO BE SO BOUND, AND THAT YOUR RECEIPT OF THE WARRANTY AND PRODUCT, AND ANY PAYMENT FOR THESE, SIGNIFIES THAT YOU HAVE VOLUNTARILY AND KNOWINGLY CONSENTED TO ALL TERMS, INCLUDING THE WAIVERS AND LIMITATIONS CONTAINED HEREIN.

Specific Rights. This warranty gives you specific legal rights, and you may also have other rights that vary from state to state. Some states do not allow limitations on how long an implied warranty lasts, so that limitation may not apply to you.

Some states do not allow the exclusion or limitation of incidental or consequential damages, so that limitation or exclusion may not apply to you.

Exclusions. This Warranty only covers the Products. Due to the intended use of our Products, any and all items and components not sold by us but attached to, incorporated into, or using our Products carry NO WARRANTY WHATSOEVER from us regardless of circumstance. We will not be liable for any defects, whether due to workmanship, materials or any other reason whatsoever, for those items and components not sold by us. This Warranty also does not cover customer instruction, installation and labor (except as

provided herein), parts supplied by others, abuse, misuse, neglect, improper installation or improper repair by anyone other than us, improper usage, overloading, accidents, unreasonable use, improper loading, improper operation, improper repair, improper maintenance, normal wear and tear, color fade, mold, mildew, corrosion, rust formation, modifications, or attempted repair by anyone other than a qualified repair facility. This Warranty does not cover chemical damage caused by acids, fuel, oil, or other chemicals. Use of our Products in or as part of a unit in a rental fleet, or for a commercial purpose, voids your rights under this Warranty.

Third-Party Events. In the event of any accident, injury to person, damage to property, loss, or other occurrence involving a Product, you must notify us in writing of the circumstances within thirty (30) days of the event or within ten (10) days of notification to you, whichever is earlier. Notwithstanding this, you must notify us immediately if a survey, test, or inspection is to be conducted on a Product, and provide us with the opportunity to participate in any such survey, test or inspection, or to permit us to conduct our own survey, test or inspection in advance. Your failure to comply with this paragraph will constitute a waiver and release of all rights under this Warranty.

Statute of Limitations. Any action, lawsuit or other proceeding, under this Warranty or otherwise, related to the Product must be commenced within one (1) year after the earlier of (a) the expiration of the Warranty coverage period, (b) our alleged failure to repair the defect at issue; or (c) the date on which your claim accrues under applicable law. Unless prohibited by law, the performance of repairs will not prevent the limitations period from expiring, nor will any tolling or estoppel/ doctrine apply. This Warranty does not extend to future performance. Some states do not allow a reduction in the statute of limitations, so that reduction may not apply to you.

Applicable Law & Venue. This Warranty will be governed by and construed in accordance with the laws of the State of Ohio without regard to principles of conflicts of law. To the full extent permitted by law, any disagreement, dispute, controversy, or claim arising out of or relating to this Warranty or Product must be brought, if at all, only in a state court in Columbus, Ohio, or a federal court in the Southern District of Ohio, having jurisdiction over the subject matter. You irrevocably consent that such court will have personal jurisdiction over you and waive any objection that the court is an inconvenient forum. YOU WAIVE ANY RIGHT TO A JURY TRIAL AND CLASS ACTION RELATING TO THIS WARRANTY, AND MAY NOT JOIN OR CONSOLIDATE CLAIMS AS A REPRESENTATIVE OF A CLASS ACTION OR IN A PRIVATE ATTORNEY

GENERAL CAPACITY. In the event you bring any claim against us in violation of this Warranty or for claims waived or released under this Warranty, you agree to pay our attorney and paralegal fees and costs to defend such suit.

Modifications. We will not be liable for commitments, promises, or agreements made by any employee, agent, or dealer that is not in accordance with this Warranty. The current WARRANTIES and terms outlined on the Warrantor's website applicable on the date of purchase take precedence over any other WARRANTIES, whether oral or written. We reserve the right to alter our WARRANTIES from time to time, as the laws and our business needs and industry change. Any conditions or exceptions that may be stated in any communication or document to us from any entity or individual, including but not limited to you, shall be of no effect unless specifically agreed to in writing and hand-signed by our authorized representative.

Miscellaneous. Any legally or otherwise invalid provision hereof will be considered severable, with all remaining provisions enforceable. We have all rights and remedies given to sellers by applicable law, and our rights and remedies are cumulative and may be exercised from time to time. No waiver by us of any provision of this Warranty will be effective unless in writing, nor will it operate as a novation or waiver of any other provision or affect our right to exercise thereafter any right or remedy. We will not lose any right because we have not exercised that right in the past.

OWNER'S RESPONSIBILITY

To ensure trouble free warranty coverage it is important that you register your hot water heater. You may register on-line at the links presented below or by filling out and returning to RVMP the warranty registration card supplied with your hot water heater. Registering your product confirms your warranty coverage and provides a direct link between you and RVMP if we find it necessary to contact you. Please visit www.rvmp.co to complete your warranty registration information.

Visit <https://warranty-fgsbmc11.rvmp.co> or
Scan the QR Code below to register your hot water heater:





Product Details & Digital Manual

Product Warranty Registration



RV Mobile Power, LLC

Phone: (855) HAPPYRV

www.rvmp.co

Email: support@rvmp.co

Visit rvmp.co • Copyright© 2023 RV Mobile Power, LLC. - All Rights Reserved.

**Giving you the comforts of home
wherever the road takes you.**



RV MOBILE POWER, INC
1055 W. Third Ave, Columbus, OH 43212



View complete features,
specs and details on:

(855) HAPPYRV

www.rvmp.co

support@rvmp.co