

CORDLESS VACUUM CLEANER

USER MANUAL

—
Elite 7

Laresar

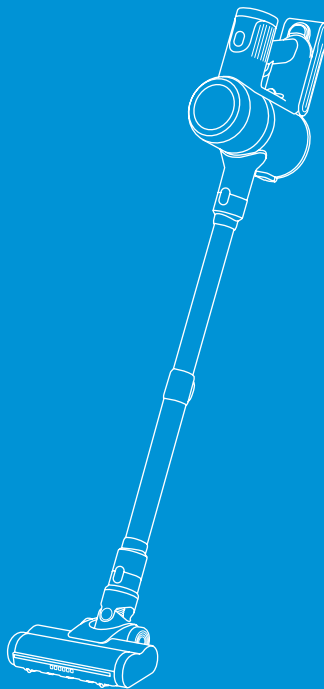

CONTENTS

1.IMPORTANT SAFETY WARNING	4
1.1 Precautions When Using	-4
1.2 Notes on the Battery Pack	-5
1.3 Notes on Charging	-6
1.4 Storage and Maintenance Precautions	-7
2.PACKAGE CONTENT	9
3.OVERVIEW	11
3.1 Overview	-11
3.2 Animated Screen Indicators	-12
4.ASSEMBLING & USE	13
4.1 Product Assembling and Use	-13
4.2 How to Use	-14
4.3 Abnormal Indicator	-15
5.CHARGING METHODS	16

5.1 Charging Methods - - - - -	-16
5.2 Wall Mount- - - - -	-17
6.MAINTENANCE- - - - -	18
6.1 Main Body Cleaning - - - - -	-18
6.2 Empty the Dust Cup- - - - -	-18
6.3 Clean the Filter- - - - -	-19
6.4 Brush Roller Cleaning - - - - -	-20
7.SPECIFICATION - - - - -	20
8.TROUBLESHOOTING- - - - -	21
9.WARRANTY - - - - -	22

1.IMPORTANT SAFETY WARNING

⚠ATTENTION: Before using this machine, please read all instructions in the manual and cautionary markings on the machine carefully.

1.1 Precautions When Using

01. This Laesar machine is not intended for use by persons (including children) with reduced physical, sensory or reasoning capabilities, or lack of experience and knowledge, unless they have been given supervision or instruction concerning use of the machine by a person responsible for their safety.
02. Use only as described in this Laesar User Manual. If the machine is not working as it should, if it has received a sharp blow, if it has been dropped, damaged, left outdoors, or dropped into water, do not use and contact the Laesar Support Team.
03. Suitable for dry locations ONLY. Do not install, charge or use this machine outdoors, in a bathroom or within 10 feet (3 meters) of a pool. Do not use on wet surfaces and do not expose to moisture, rain or snow.
04. When using this machine, please keep hair, loose clothing, fingers, and all parts of the body away from openings and moving parts. Do not point the hose, aluminium alloy tube or other accessories at your eyes or ears or put them in your mouth.
05. Do not use to pick up hard objects, such as glass slag, needles,nails, etc.
06. Do not touch the charger with wet hands to avoid electric shock.
07. Use only Laesar recommended accessories and replacement parts.
08. Do not use without the dust cup and filter(s) in place.

09. When removing or replacing a motorized brush bar, be careful not to pull the power button until the cleaner head has been reassembled.
10. Do not water or spill liquid onto the vacuum cleaner. If that happens, it will increase the risk of electric shock.
11. Use extra care when cleaning on stairs.
12. Please do not use the vacuum cleaner to suck the detergent, kerosene, soot, wet dust, water, sewage, matches and other items.
13. Please do not use a vacuum cleaner to suck up small particles such as cement, gypsum powder, wall powder, or large objects such as toy paper balls, otherwise it will cause the vacuum cleaner to block and the motor to burn out.

1.2 Notes on the Battery Pack

01. Do not throw the battery pack away, and it should be safely disposed in accordance with local regulations.
02. Do not use a battery pack or machine that is damaged or modified. Damaged or modified batteries may exhibit unpredictable behavior resulting in fire, explosion or risk of injury.
03. Do not incinerate batteries or expose to high temperatures, as they may explode.
04. The battery is a sealed unit and under normal circumstances poses no safety concerns. In the unlikely event that liquid leaks from the battery, do not touch the liquid as it may cause irritation or burns, and observe the following precautions:

Skin contact – can cause irritation. Wash with soap and water.

Inhalation – can cause respiratory irritation. Expose to fresh air and seek medical advice.

Eye contact – can cause irritation. Immediately flush eyes thoroughly with water for at least 15 minutes. Seek medical attention.

Disposal – wear gloves to handle the battery and dispose of immediately, following local ordinances or regulations.

05. When the battery pack is not in use, keep it away from paper clips, coins, keys, nails, screws or other small metal objects that could make a connection from one terminal to another.

1.3 Notes on Charging

01. Before use, check the charger cord for signs of damage or ageing. A damaged or entangled charger cord increases the risk of fire and electric shock.

02. Never modify the charger in any way.

03. The charger has been designed for a specific voltage. Always check that the mains voltage is the same as that stated on the rating plate

04. Unplug the charger when not in use for extended periods.

05. When your vacuum cleaner is fully charged , needs to be cleaned or repaired, please unplug the charger in time and do not pull the power cord directly.

06. Do not pull the cord to disconnect from a socket, grasp the plug and pull to disconnect.

07. Don't wrap the cord around the charger when storing.

08. Please fully recharge the battery, when first used or used after long time storage. If the product is not used for long time, please make sure the battery is recharged and used each three months at least.

09. If smoke or fire occurs during charging, unplug the charger immediately, and use a fire extinguisher to put out the fire . Do not use water to extinguish the fire, it will increase the risk of electric shock.

10. Follow all charging instructions and do not charge the battery pack or the machine outside of the temperature range specified in the instructions. Charging improperly or at a temperature outside of the specified range may

damage the battery and increase the risk of fire. To ensure maximum battery life, Laesar recommends the following:

When not in use the machine should be stored at room temperature. Recommended range: 64°F (18°C) to 82°F (28°C).

The ambient temperature range for operation and charging should be 50°F (8°C) to 86°F (35°C).

1.4 Storage and Maintenance Precautions

01. Please store the product under cool and dry environment. Please avoid long-time sunshine on the product.
02. The charger must be removed from the socket before removing the battery, cleaning or maintaining the appliance.
03. Please use dry cloth to clean the vacuum cleaner. Please do not use gas or liquid that can make the surface cracked or color faded.
04. Do not apply any fragrance or scented product to the filter(s) of this machine. The chemicals in such products are known to be flammable and can cause the machine to catch fire.
05. Do not carry out any maintenance other than that shown in this manual, or advised by the Laesar Support Team.
06. Do not disassemble the machine as incorrect reassembly may result in an electric shock or fire. Contact the Laesar Support Team when a service or repair is required.

SAVE THESE INSTRUCTIONS

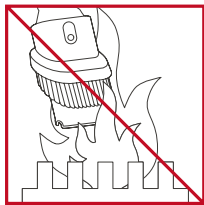

Do not use near open flames.

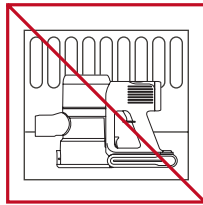

Do not store near heat sources.

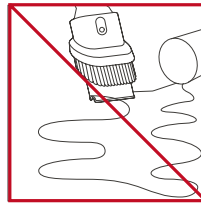

Do not pick up water or liquids.



Do not pick up burning objects.

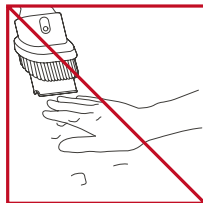



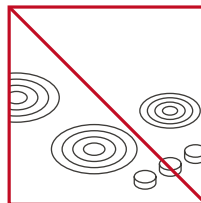





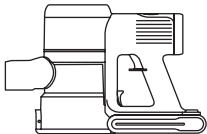

Do not put hands near the brush bar when the machine is in use.

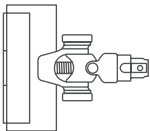
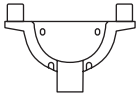
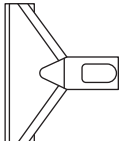

Do not place on or near the cooker.

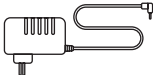
2.PACKAGE CONTENT

Please check and confirm the accessories and parts according to the following sheet before using.

<p>Main Body</p> 	<p>Retractable Tube</p> 	<p>Motorized Brush Head</p> 	<p>Wall Mount (Screw*5, Expansion Nails*5)</p> 
<p>Sofa Brush</p> 	<p>2 in 1 Upholstery Brush</p> 	<p>Long Crevice Nozzle</p> 	<p>Battery Pack</p> 
<p>Charger</p> 	<p>HEPA filter and Sponge</p> 	<p>Mini Cleaning Brush</p> 	<p>User Manual</p> 

3.OVERVIEW

3.1 Overview

Introduction of components:

- 01. Air Outlet HEPA Filter
- 02. Touch Screen
- 03. Main Body Removal Button
- 04. Battery Removal Button
- 05. Switch Button
- 06. Dust Tank Release
- 07. Dust Release Button
- 08. Retractable Tube Adjustment Button
- 09. Electric Floor Brush Removal Button

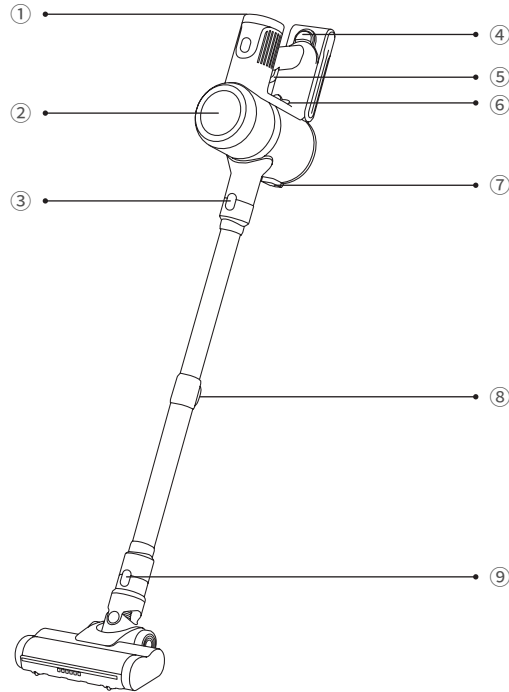

3.2 Touch Screen Indicators

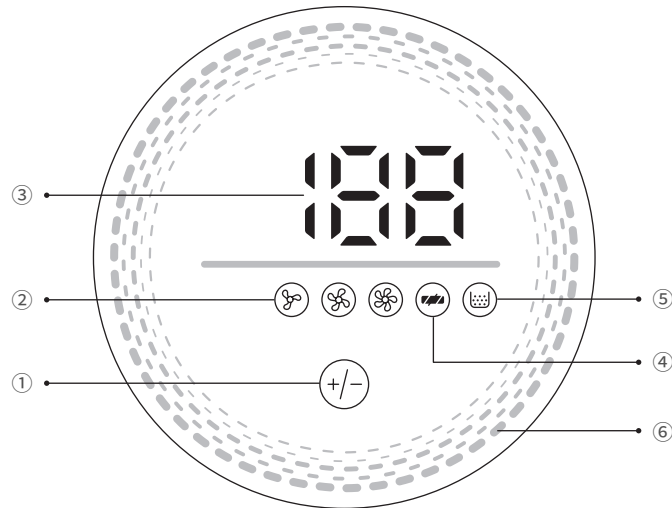

01. Touch to Adjust Speed

02. Suction Level Display

03. Battery Display

04. Ground Brush Stall Prompt

05. Dust Cup Cleaning Tips

06. Ambient Light

4.ASSEMBLING & USE

4.1 Product Assembling and Use

4.1.1 Install the Battery Pack

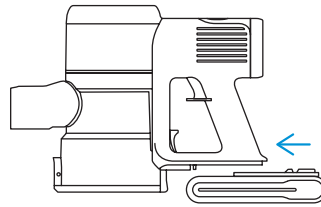

4.1.2 Install Cleaning Accessory

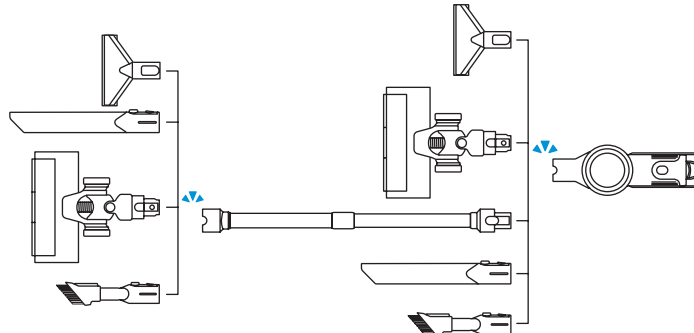

4.2 How to Use



Before use, make sure that

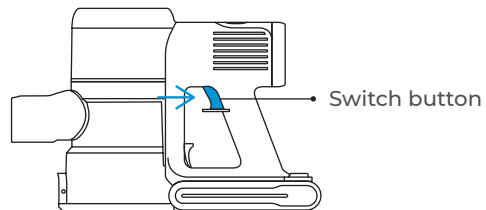

- The battery is fully charged, and fixed in place.
- The dust cup and filters are cleaned, dried, and fixed in place.

4.2.1 Start to Work



Press the switch button, the appliance will start to work. Press the button again to shut down the appliance.

4.2.2 Select Cleaning Mode

- Boot into “Eco” Mode
- Touch  to “Standard” Mode
- Touch  Again to “Boost” Mode

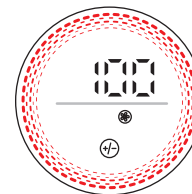
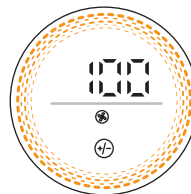

4.3 Abnormal Indicator

When the battery level is under 10%, the battery indicator on the screen will start to flash in red. The vacuum cleaner should be charged as soon as possible.



When the brush roller is blocked, the LED light on the motorized brush goes out, and the red brush roller indicator light keeps flashing until it is manually turned off.

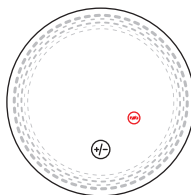

When the host is blocked, the red cup full reminder flashes for 10 seconds and then goes out.

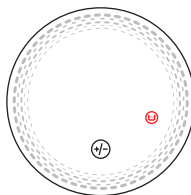

5.CHARGING METHODS

5.1 Charging Methods

During the work of the machine, when the power display is only 10%, the power display number will flash. This is a reminder that the battery is low and should be charged in time to avoid affecting the use.

Method 1:

The product can be charged on the storage wall-mount. The digital screen will be showed the charging process ,when at 100% ,the battery is full.

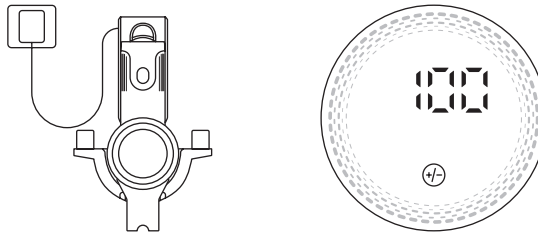

Method 2:

The battery package can be pulled out and charged separately. The battery indicator light will be flashing in blue, When the battery is fully charged, the blue light is always on.

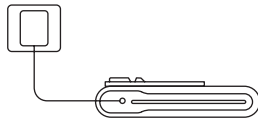

- Blue light flashing (Charging)
- Blue light (Fully Charged)

5.2 Wall Mount

Hold the charging wall mount against the wall through the two fixing screw holes and fix it onto the wall with screws, and then hang the vacuum cleaner on the wall.



Warning

- Please make sure there is no gas, water or electrical cables and wires behind the mounting area.
- To avoid the dock dropping down, please make sure it must be installed firmly.

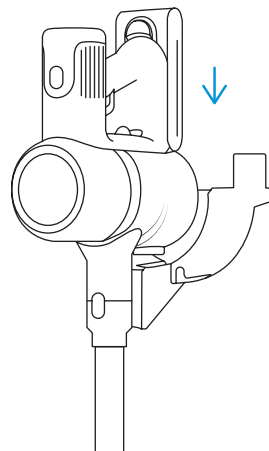
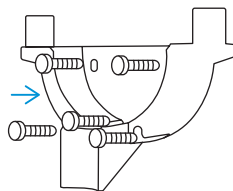

6.MAINTENANCE

Please clean it regularly to prolong the service life of the vacuum cleaner.

6.1 Main Body Cleaning

- Turn off the power before cleaning the body.
- Please use a neutral detergent, wipe the body with half-wet cloth.
- Please avoid sun exposure and store in a cool and dry place.

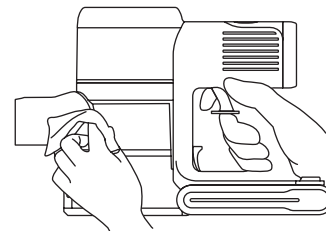

6.2 Empty the Dust Cup

- Press the dust cup release button to empty the dust.
- When using, if the garbage in the dust cup exceeds MAX line, please empty it in time.

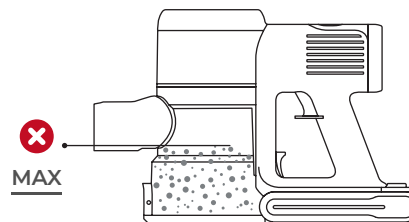
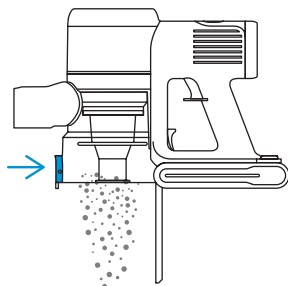

6.3 Clean the Filter

The dust cup release lever is pulled back and the dust cup can be disengaged and unlocked for cleaning.

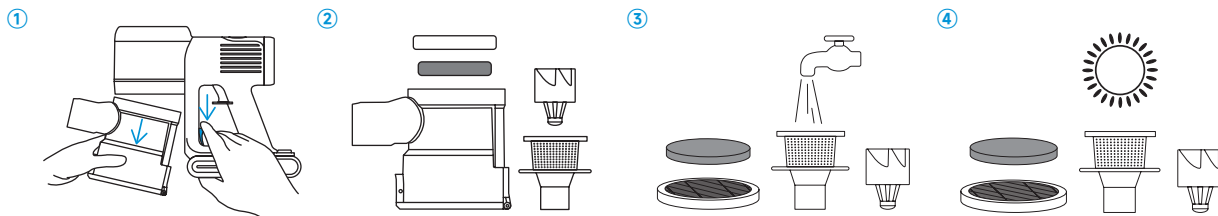

Note

- The filter case and HEPA filter have to be cleaned once in two weeks. The HEPA filter has to be replaced every two months if necessary. Please ensure the filters are completely dry before reassembly.

6.4 Brush Roller Cleaning

Note: After long periods of use, the bristle may be jammed by hair or similar build-up. It's recommended to clean the brush roller periodically to ensure efficient operation and maintain suction.

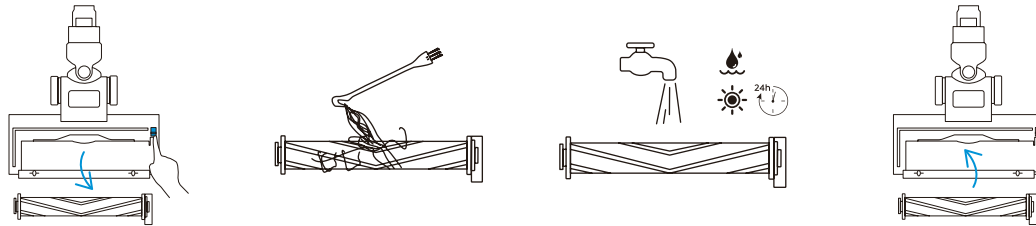

7.SPECIFICATION

Product	Cordless Vacuum Cleaner
Model	Elite 7
Rated Voltage	22.2V ===
Adapter Output	26.5V === 550 mA
Adapter Input	100-240 V~50/60Hz
Cleaning Modes	Low/Middle/High

8.TROUBLESHOOTING

ISSUE	CAUSE	SOLUTION
Weak suction power	<ul style="list-style-type: none"> ① Filter element blocked/deformed ② The expansion tube is blocked by foreign objects ③ Air leakage from broken brush hose 	<ul style="list-style-type: none"> ① Clean/replace the filter ② Clean the telescopic tube ③ Contact customer service to replace the floor brush
Cannot be turned on	<ul style="list-style-type: none"> ① The switch of vacuum cleaner is not working ② The filter system is blocked and the main unit is blocked to trigger automatic protection ③ Battery damage/short circuit in other parts 	<ul style="list-style-type: none"> ① Contact customer service to replace the switch ② Clean/replace the filter ③ Contact customer service for investigation
The brush does not rotate	<ul style="list-style-type: none"> ① The brush is entangled with hair ② The electric floor brush is damaged/short-circuited ③ Metal tube short circuit failure 	<ul style="list-style-type: none"> ① Clean the hair on the roller ② Contact customer service to replace the brush ③ Contact customer service to replace the metal tube
Battery cannot be charged	<ul style="list-style-type: none"> ① Loose charging port ② Wrong adapter ③ Adapter/battery damaged 	<ul style="list-style-type: none"> ① Reconnect charging ② Use the correct adapter ③ Contact customer service to replace the adapter/battery
Auto shutdown after power on	<ul style="list-style-type: none"> ① Battery is not fully charged (wrong adapter/ loose charging port) ② The filter system is blocked, the host blockage triggers automatic protection ③ Short circuit of the telescopic tube/folding tube/electric floor brush 	<ul style="list-style-type: none"> ① Reconnect charging / use the correct adapter ② Clean/replace the filter ③ Contact customer service for replacement

9.WARRANTY

The 2-Year Limited Warranty

- Your Laesar machine has a 2-year warranty against original defects in material and workmanship, when used for private household purposes in accordance with the Laesar Instruction Manual.
- This warranty provides, at no extra cost to you, all labor and parts necessary to ensure your machine is in proper operating condition during the warranty period.

WHAT IS COVERED?

According to the requirements outlined in this instruction manual, subject to the following conditions and exclusions.

Only applies to purchases made from authorized retailers of Laesar.

This warranty will only be valid if the machine is used in the country in which it was sold.

WHAT IS NOT COVERED?

Laesar shall not be liable for costs, damages or repairs incurred as a result of:

- Machines purchased from an unauthorized dealer.
- Careless operation or handling, misuse, abuse and/or lack of maintenance or use not in accordance with the Laesar Instruction Manual.
- The machines are used for commercial or rental purposes in addition to normal domestic use.
- Use of parts not in accordance with the Laesar Instruction Manual.
- Use of parts and accessories other than those produced or recommended by Laesar.

- External factors unrelated to product quality and use, like accidental water damage.
- Repairs or alterations carried out by unauthorized parties or agents.
- Normal wear and tear, including Dust Cup, Belt, Filter, HEPA, Brush Roller, and Power Cord (or where external damage or abuse is diagnosed), carpet or floor damage due to use not in accordance with manufacturer's instructions or failure to turn the brush roller off when necessary.
- Reduction in battery discharge time due to battery age or use.

HOW TO CLAIM?

Please keep your proof of purchase. To make a claim under our Limited Warranty, you need to provide your original purchase receipt with the purchase date and order number on it.

All work will be carried out by Laresar or its authorized agency.

Any replaced defective parts will become the property of Laresar.

Service under this warranty will not extend the period of this warranty.

If your machine is not functioning properly, or you still have any questions after reading this manual carefully, please feel free to contact us, we will try our best to provide you with a satisfactory solution.



E-mail our Customer Service:
support@laresar.us

Laresar is here to help and we are glad to serve you.



US



CA

Correct Disposal of This Product



This marking indicates that this product should not be disposed with other household wastes throughout the EU. To prevent possible harm to the environment or human health from uncontrolled waste disposal, recycle it responsibly to promote the sustainable reuse of material resources. To return your used device, please use the return and collection systems or contact the retailer where the product was purchased. They can take this product for environmental safe recycling.

FCC STATEMENT:

This equipment has been tested and found to comply with the limits for a Class B digital device, pursuant to part 15 of the FCC Rules. These limits are designed to provide reasonable protection against harmful interference in a residential installation. This equipment generates uses and can radiate radio frequency energy and, if not installed and used in accordance with the instructions, may cause harmful interference to radio communications. However, there is no guarantee that interference will not occur in a particular installation. If this equipment does cause harmful interference to radio or television reception, which can be determined by turning the equipment off and on, the user is encouraged to try to correct the interference by one or more of the following measures:

- Reorient or relocate the receiving antenna.
- Increase the separation between the equipment and receiver.
- Connect the equipment into an outlet on a circuit different from that to which the receiver is connected.
- Consult the dealer or an experienced radio/TV technician for help

Changes or modifications not expressly approved by the party responsible for compliance could void the user's authority to operate the equipment.

This device complies with Part 15 of the FCC Rules. Operation is subject to the following two conditions:

- (1) this device may not cause harmful interference, and
- (2) this device must accept any interference received, including interference that may cause undesired operation.

Declaration of Conformity

We (EU based importer is responsible for this declaration)

Prolinx GmbH
(Company name)

Brehmstr.56, 40239 Duesseldorf, Germany
(Company address)

declare under our sole responsibility that the product
Trade name: Laesar
Equipment: Vacuum Cleaner
Model No. : Elite 7

to which this declaration relates is in conformity with the essential requirement set out in the Council Directive on the Approximation of the laws of the Member States relating to LVD Directive(2014/35/EU) & EMC Directive(2014/30/EU) & RoHS(2011/65/EU) product is responsible to affix CE marking, the following standards were applied:

EN 60335-2-2:2010+A11:2012+A1:2013
EN 60335-1:2012+A11:2014+A13:2017+A1:2019+A14:2019+A2:2019
EN 62233:2008
EN 55014-1:2021
EN 55014-2:2021
EN IEC 61000-3-2:2019+A1:2021
EN 61000-3-3:2013+A2019

IEC62321-3-1:2013
IEC62321-4:2013
IEC62321-5:2013
IEC62321-6:2015
IEC62321-7-1:2015
IEC62321-7-2:2017
IEC62321-8:2017

Full Name: George.wang
Signature: 

Position: Approbation Manager
Place/Date: Shenzhen,China/Jun.28-2023



CONTACT INFORMATION

