

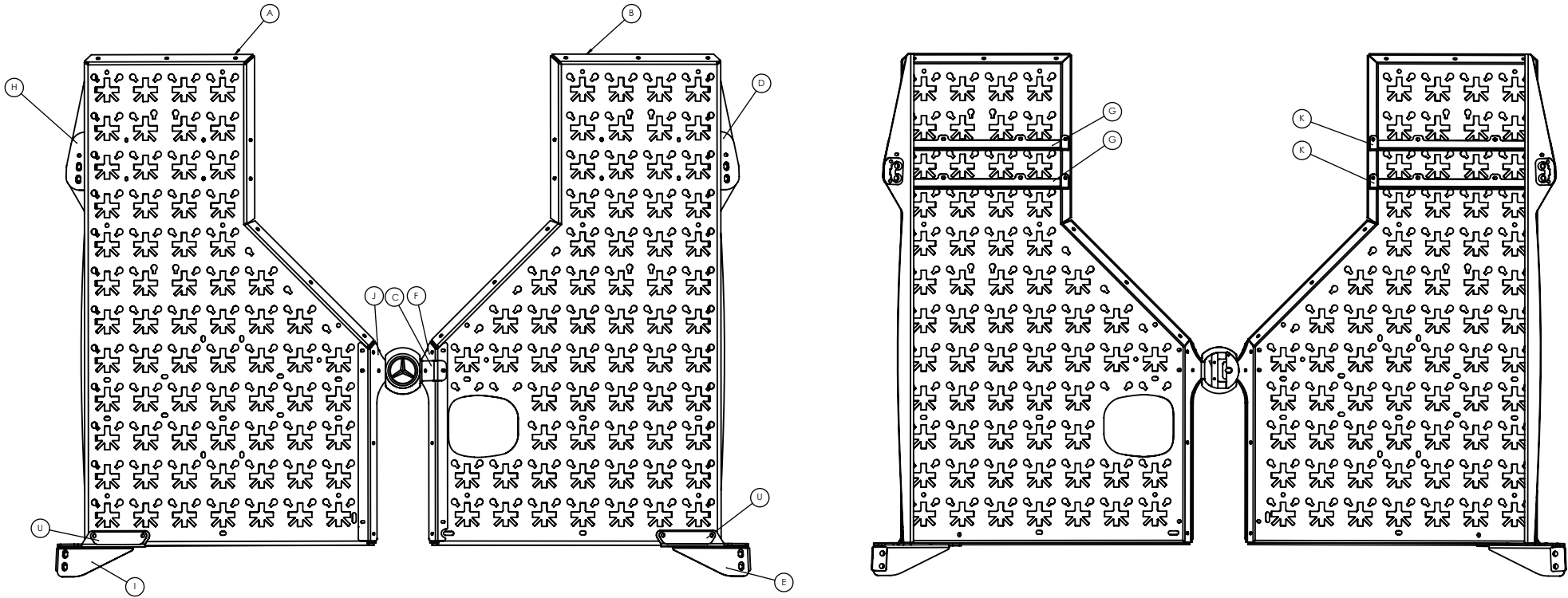

NVADER RACK

ASSEMBLY INSTRUCTIONS

Note: Start with assembly instructions first.
This requires two people. You will
need a hand with a couple of steps.



ASSEMBLY PARTS LIST

PART NAME	DESCRIPTION	QTY.
A	LEFT PANEL	1
B	RIGHT PANEL	1
C	BADGE RETAINER BRACE	1
D	RIGHT UPPER HINGE BRACE	1
E	RIGHT LOWER HINGE BRACE	1
F	RIGHT CENTER BRACE	1
G	RIGHT REAR BRACE	2
H	LEFT UPPER HINGE BRACE	1
I	LEFT LOWER HINGE BRACE	1
J	LEFT CENTER BRACE	1
K	LEFT REAR BRACE	2
U	LOGO PLATE	2

ASSEMBLY HARDWARE LIST

	DESCRIPTION	QTY.
	1/4-20 X 1" CARRIAGE BOLT	2
	NYLON-INSERT LOCKNUT FOR 1/4-20 SIZE BOLT	40
	WASHER FOR 1/4" SIZE BOLT	40
	1/4-20 X .75" CARRIAGE BOLT	38
	ALUMINUM UNTHREADED SPACER	2
	THREADED-STUD BUMPER	2
	WASHER FOR 3/8" SIZE BOLT	2
	NYLON-INSERT LOCKNUT FOR THREADED-STUD BUMPER	2

A

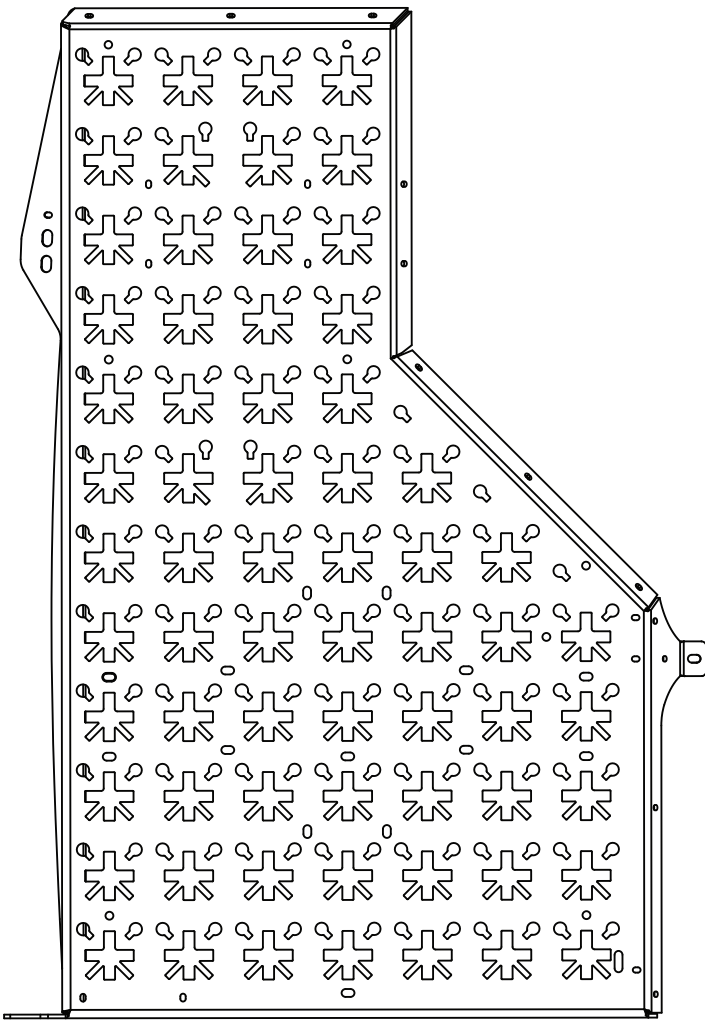

B

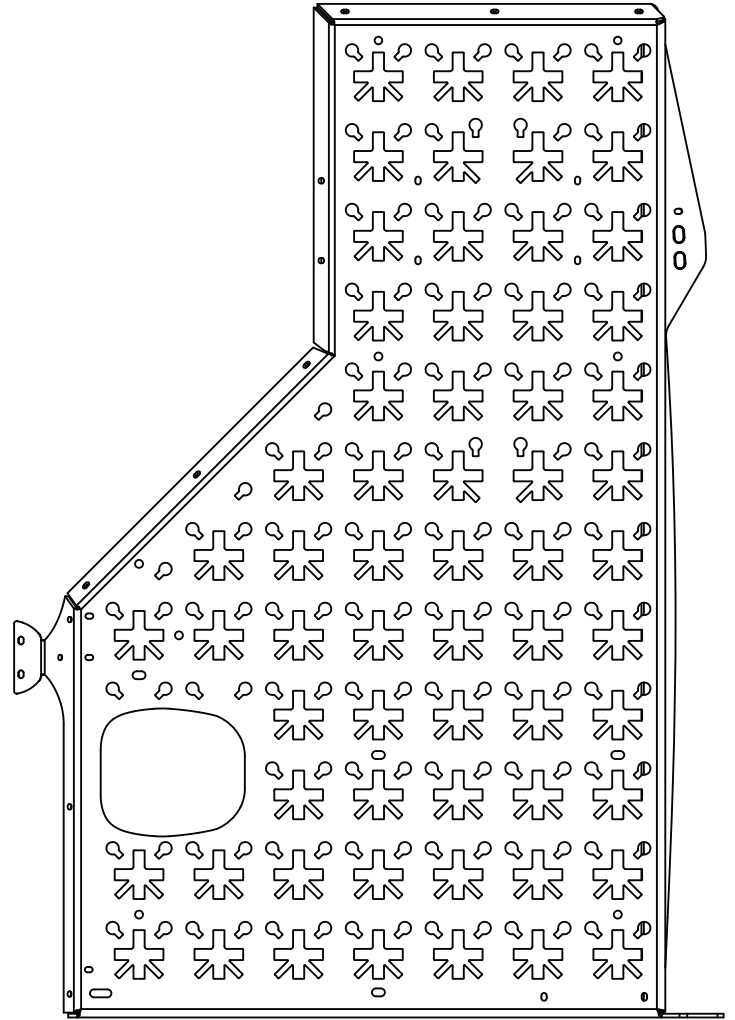

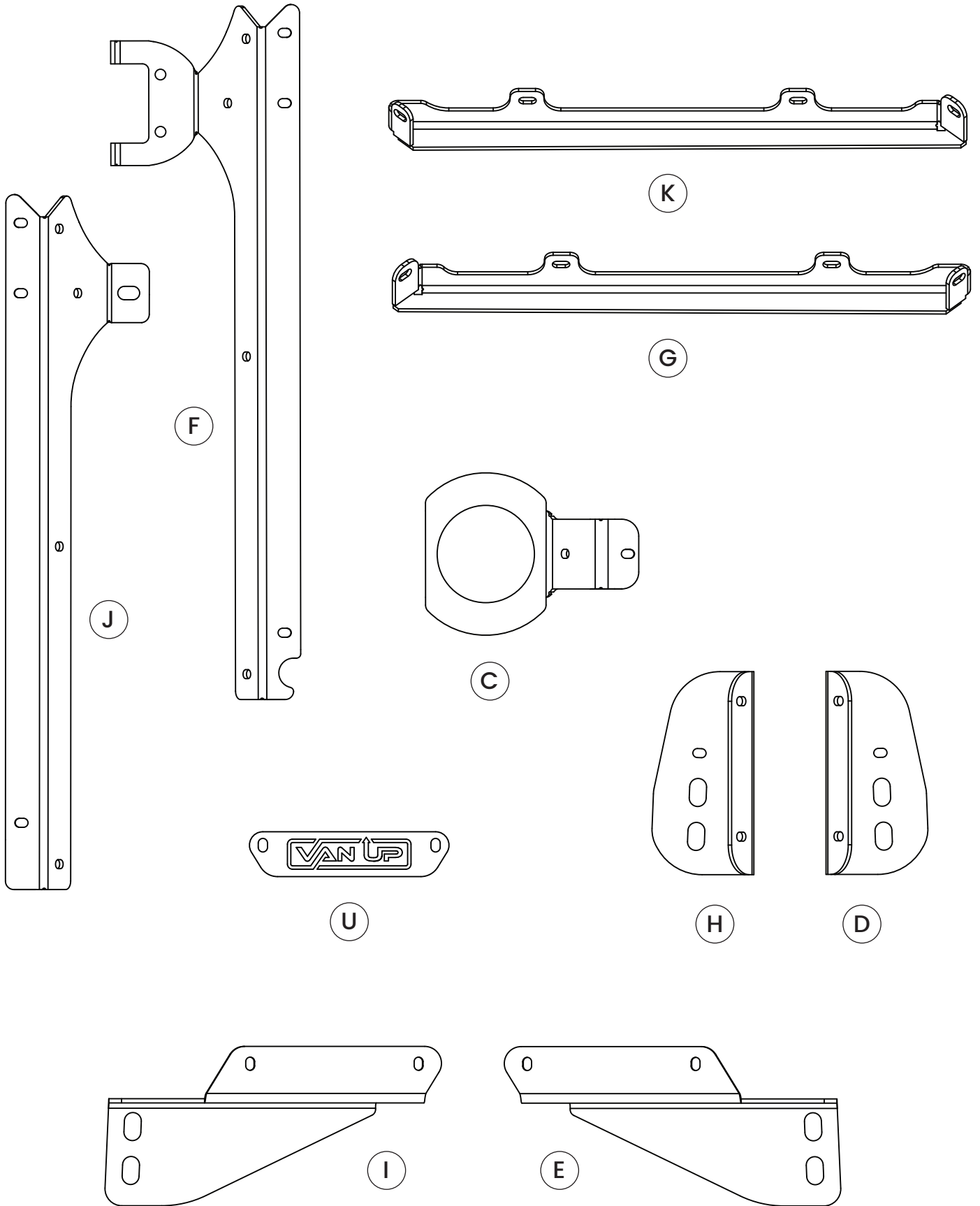

1. Retrieve passenger side rack (part B) and set face down on a support box with protective covering to allow for easy access to top and bottom faces of the rack. See figure 1.

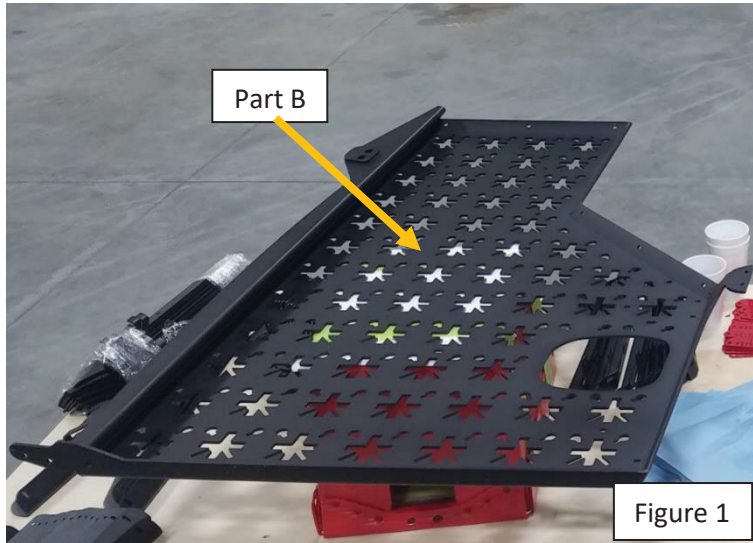

2. Assemble the passenger side upper hinge mount
 - a. Set (2) Nvader rack parts G onto the inside of the rack plate to align the slots in part G with the mounting holes as shown in figure 2.

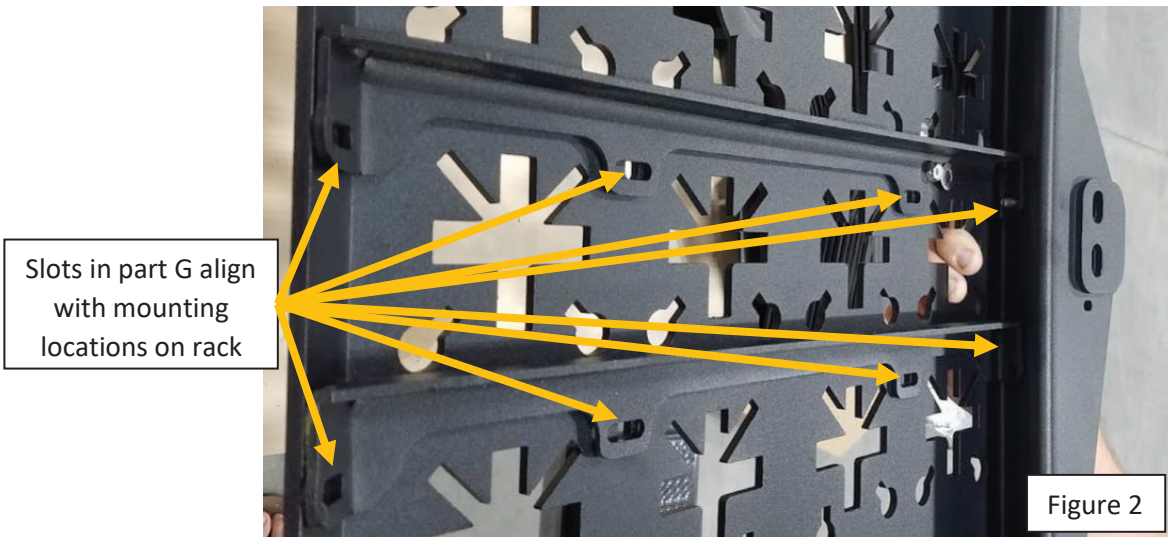

- b. Align part D onto the outer z-fold area of the Nvader rack next to where the G parts were placed. See figure 3.



- c. Install (8) 1/4"-20 x 3/4" SS black oxide carriage bolts with 1/4" SS washers and 1/4"-20 SS thin nylock nuts. Ensure the washers and nuts are located on the inside of the rack as shown in figure 4.



- d. Using a 7/16" open end wrench, tighten the (2) nuts in the z-fold area shown in figure 5a. Make sure the square head of the carriage bolt is fully seated in the slot (figure 5b) on the outside of the rack to prevent stripping out the slot. Keep pressure against the bolt head to keep it from backing out. Tighten with wrench by hand until tight and the bolt is fully engaged with the nylon lock on the nut. **NOTE: If the bolt starts to slip while tightening, carefully remove the nut and washer, hammer the bolt into the slot with a dead blow hammer, then reattempt to tighten the nut.**

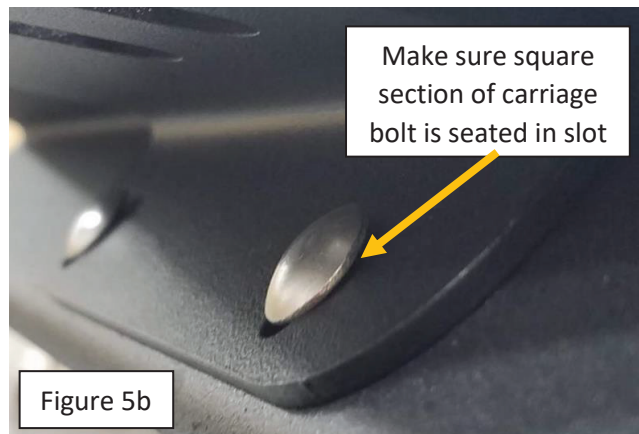
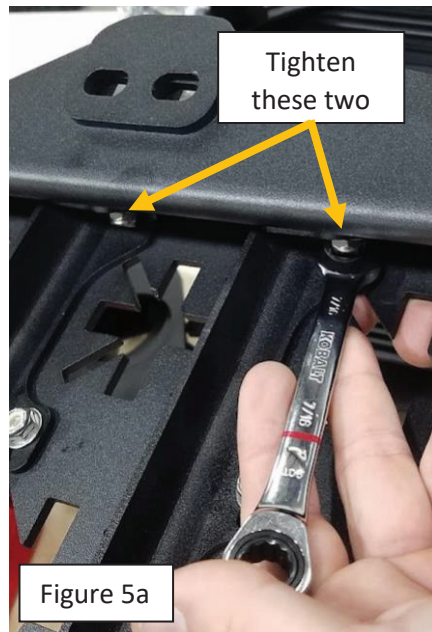

- e. Next, tighten the (2) bolts on the opposite end of bracket G with impact and 7/16" socket (figure 6), again making sure the carriage bolt is fully seated in the slot on the rack to prevent stripping.

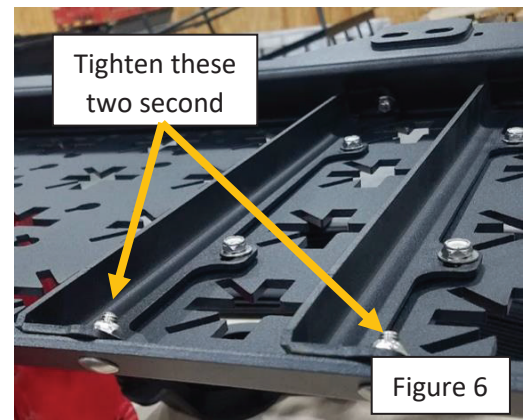

- f. Tighten the last (4) nuts using same technique as in the previous step.
- g. Cut approx. 1.5" of 1" foam tape and stick onto the upper hinge mount spacer as shown in figure 7.

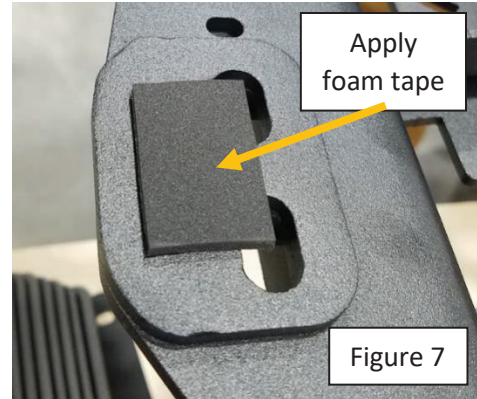

- 3. Assemble the passenger side lower hinge mount
 - a. Rotate the rack on the support box to access the lower hinge mount area.
 - b. Set part U onto part E so that the mounting slots align and the logo is right side up. Insert (1) 1/4"-20 x 3/4" SS black oxide carriage bolt through the front side as shown in figure 8.

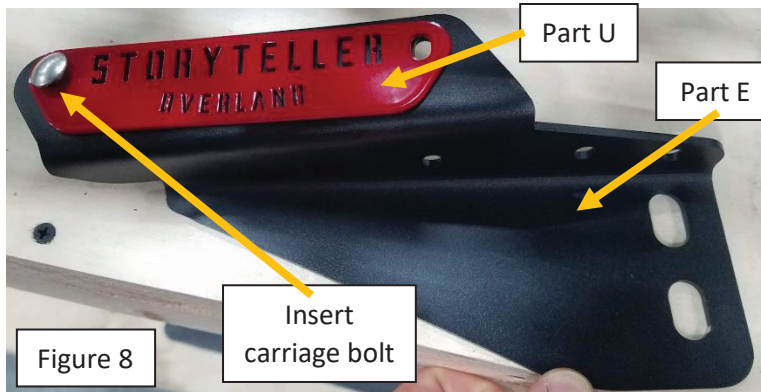

- c. Assemble parts U and E together to the lower left corner of the rack so the logo plate is on the front of the rack and the rest of the bracket extends past the bottom of the rack plate. Use (2) 1/4"-20 x 3/4" SS black oxide carriage bolts, (2) 1/4" SS washers and (2) 1/4"-20 SS thin nylock nuts. See figures 9a and 9b. **NOTE: If the outer flange is bent to where you can not start the outer bolt, gingerly hammer with a dead blow hammer to get bracket to fit better to rack plate.**

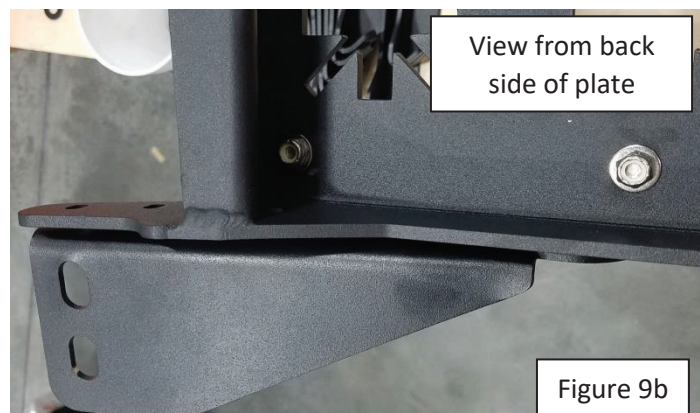
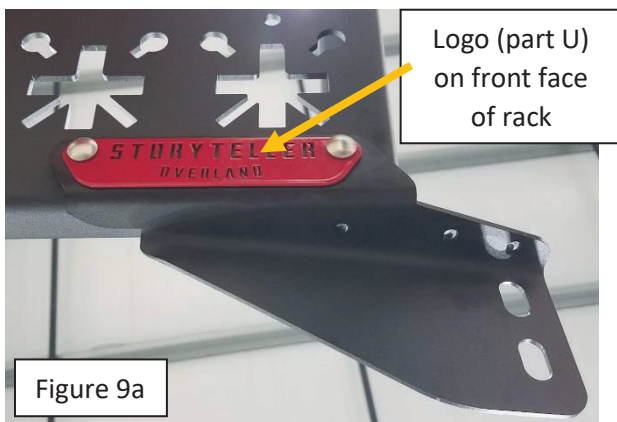

- d. Assemble the remaining (3) bolts, washers, and nuts to the lower hinge bracket. Make sure the two outermost bolts have the nuts located on the bottom of the bracket and the one innermost bolt has the bolt head on the bottom of the bracket as shown in figure 10.

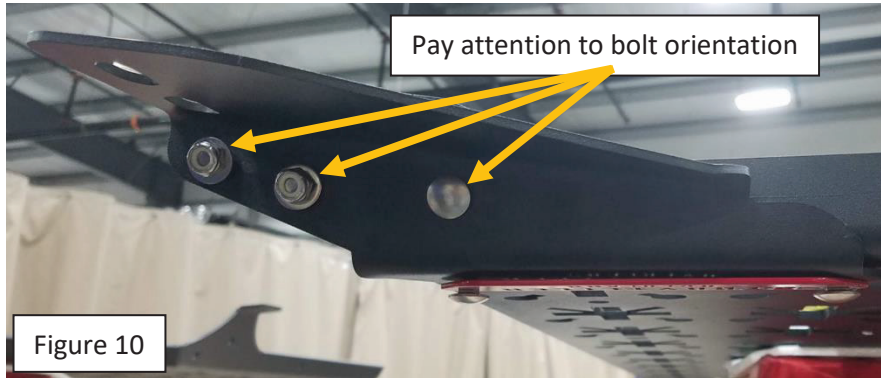

- e. Using an impact and 7/16" socket, tighten the (2) nuts on the outside bottom of the rack and bracket first while holding the logo plate and bracket flat against the rack face. Again, ensure carriage bolts are fully engaged into the slots to prevent stripping. See figure 11.

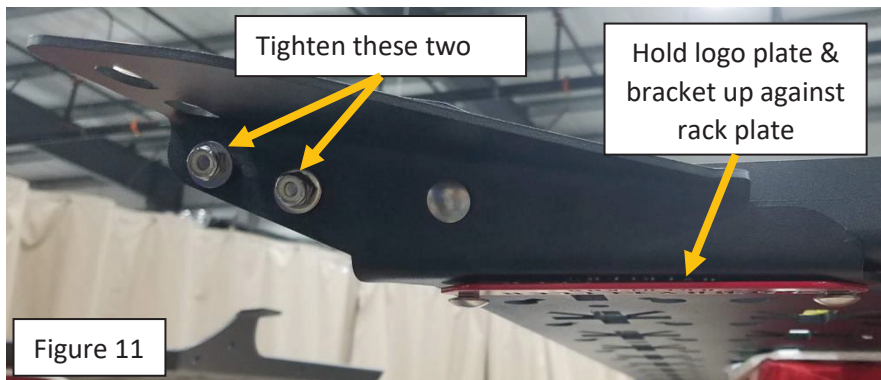

- f. Next, use a 7/16" ratcheting wrench to tighten the nut on the inside corner of the rack while holding the logo plate flat against the bracket and slid all the way up in the slots. See figure 12.

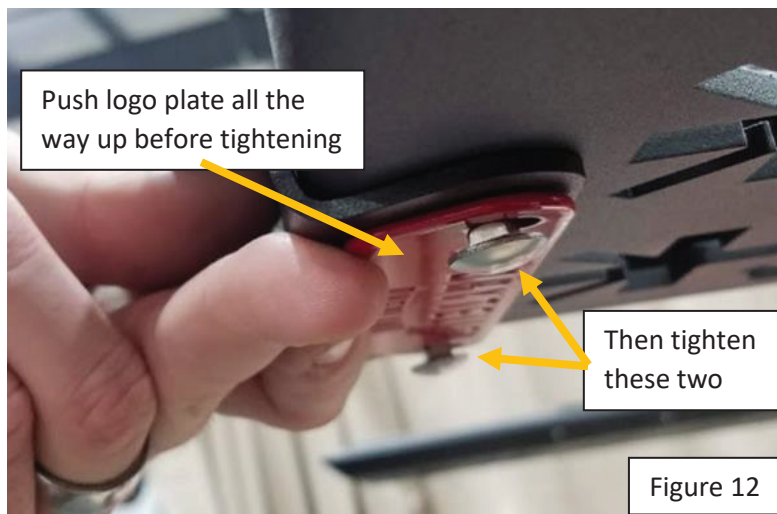

- g. Lastly, use an impact, 7/16" socket and 3" swivel extension to tighten the last nut on the inside corner of the rack as shown in figure 13.

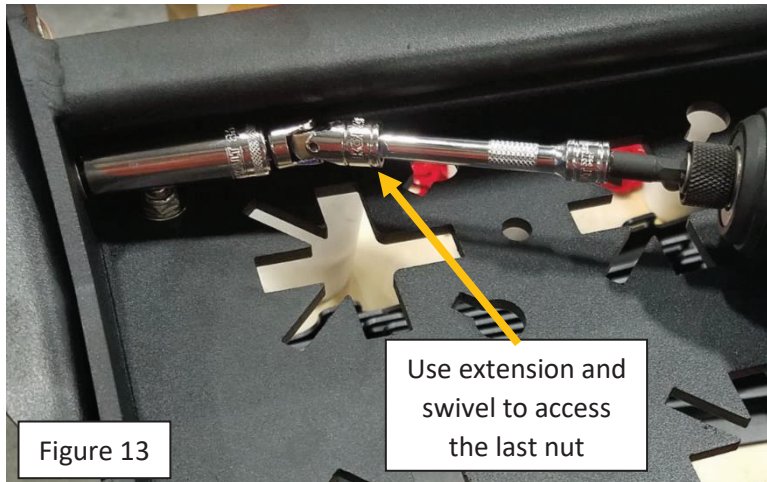

Figure 13

- h. Cut approx. 2" of 1" foam tape and install to the back side of the lower hinge mount bracket as shown in figure 14

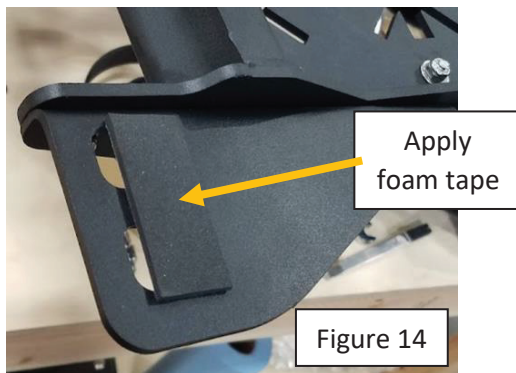

Figure 14

- 4. Assemble passenger side emblem assembly
 - a. Retrieve parts C, F, T and a Stealth center cap emblem as shown in figure 15
 - b. Using (2) 1/4"-20 x 1" SS black oxide carriage bolts, (2) 1/4" washers and (2) 1/4"-20 nylock nuts assemble parts C and F to the front face of the rack plate. Align the curvature of the parts with the curvature of the rack plate and ensure part F is sandwiched between the rack plate and part C. See figure 16.

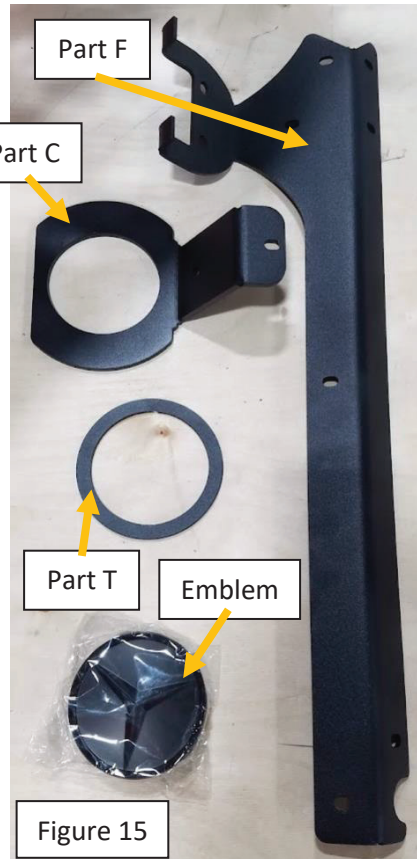

Figure 15

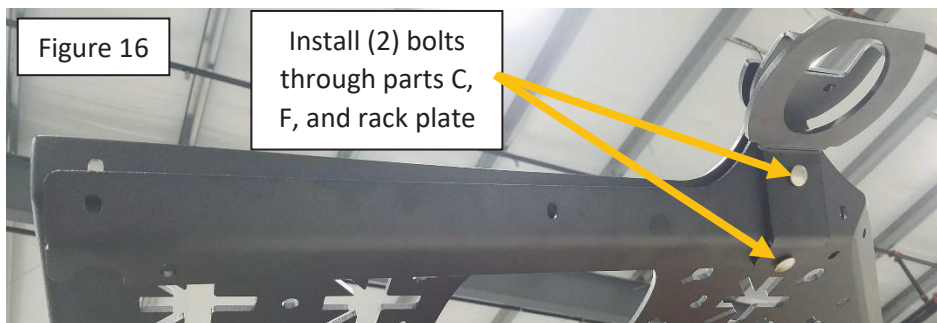
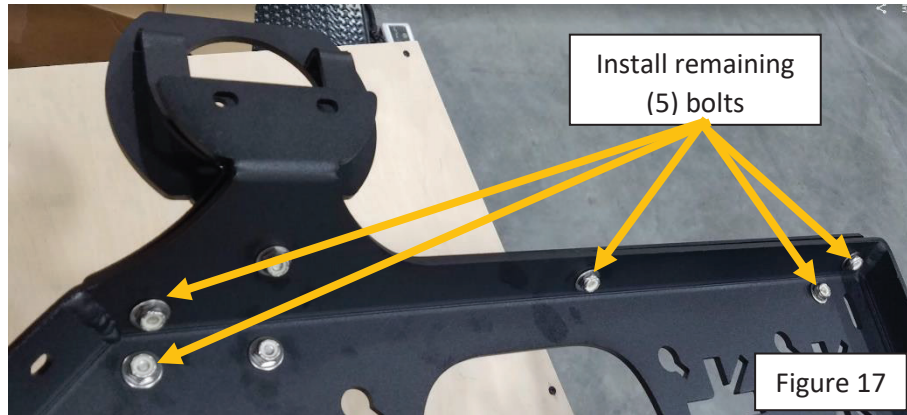

Figure 16

Install (2) bolts through parts C, F, and rack plate

- c. Loosely assemble 1/4"-20 x 3/4" SS black oxide carriage bolts, washers and nuts in the remaining (5) mounting points in part F and the rack plate. See figure 17.



- d. Align the slots in part C and the rack plate for mounting to the door, then use an impact and 7/16" socket to tighten the first nut down from the emblem mount as shown in figure 18.

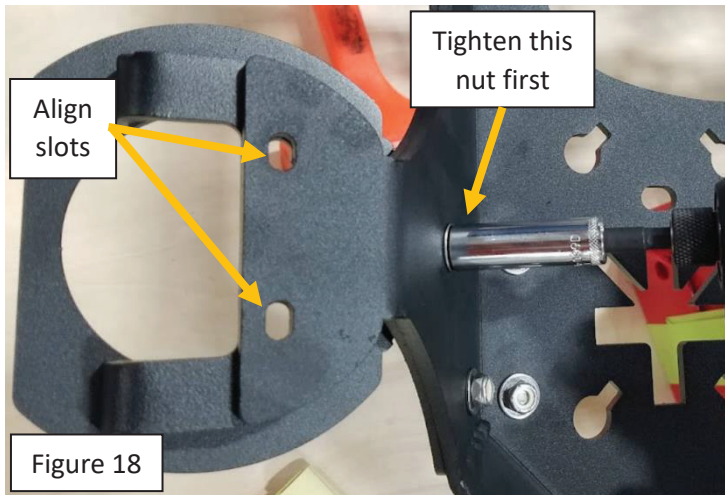

- e. Tighten remaining (6) nuts from the bottom end of the rack up to the emblem mount using an impact. Ensure part F sits flush against the rack plate and that the carriage bolts do not strip out. See figure 19.
- f. Place approx. 2.5" long strip of 1" foam tape across the door mounting section as shown in figure 20.

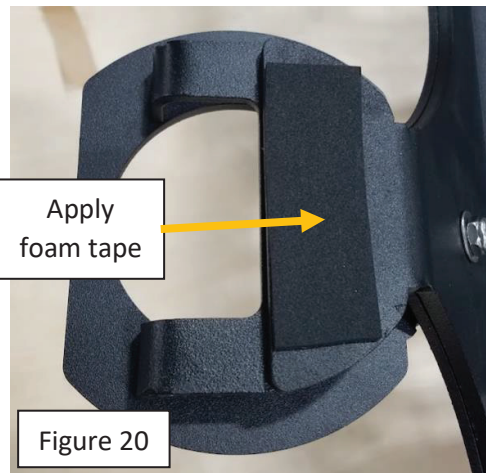
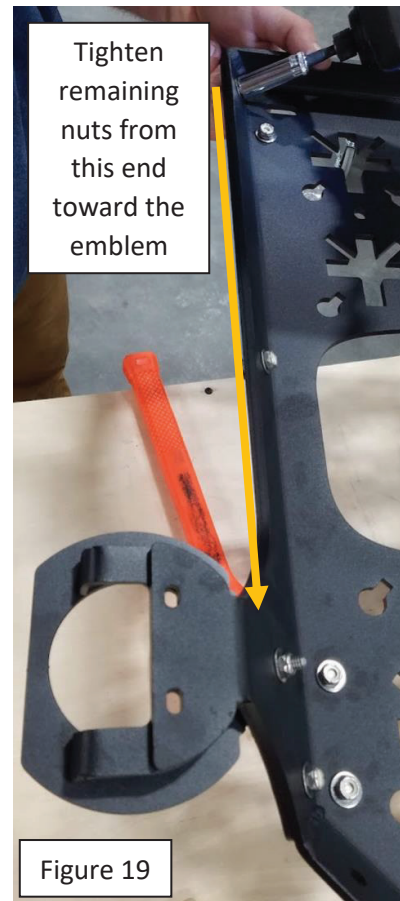

- g. Assemble the Stealth emblem into part T by snapping the tabs on the back side of the emblem into the center ring of part T as shown in figure 21.
- h. Lastly, install the emblem assembly to the rack part C by snapping the tabs on the back side of the emblem into the center opening of part C as shown in figure 22.

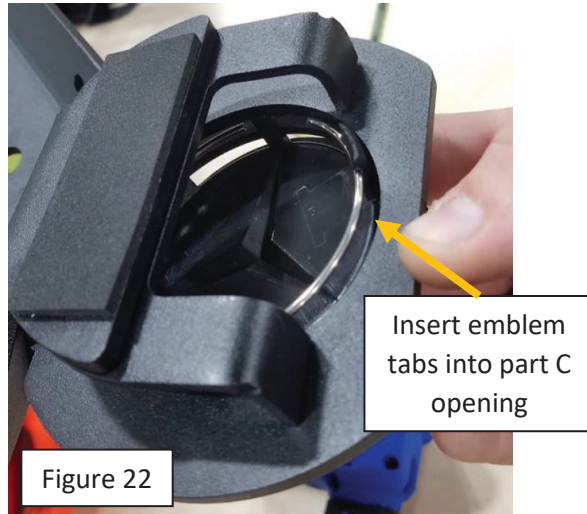

- 5. Install bumper spacer to passenger side rack plate
 - a. Set 3/8" x 3/8" unthreaded aluminum spacer onto the stud of a 3/8" threaded-stud bumper spacer with Natural Red color then install to the slot in the lower inside corner of the rack plate as shown in figure 23. Ensure the bumper is on the inside of the rack and that one of the flat edges of the bumper is against the bottom flange of the rack.
 - b. Install a 3/8" SS black oxide flat washer and a 3/8"-16 SS Thin nylock nut to the bumper stud on the outside of the rack.
 - c. Tighten the nut using an impact and a 14mm socket until the nut is tight while also ensuring the stud threads protrude through the nylon lock on the nut. See figure 24.

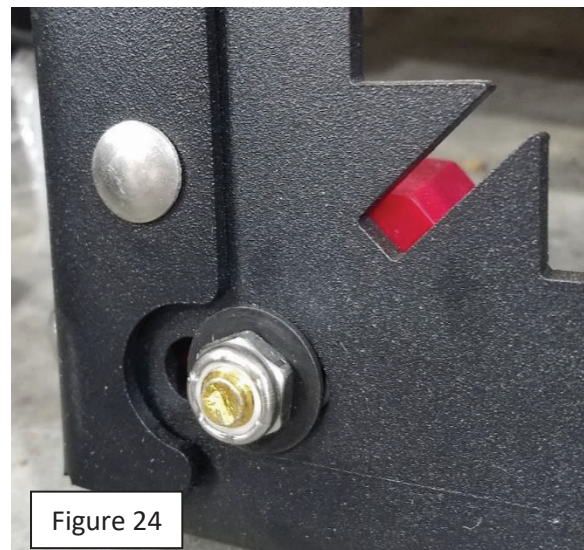
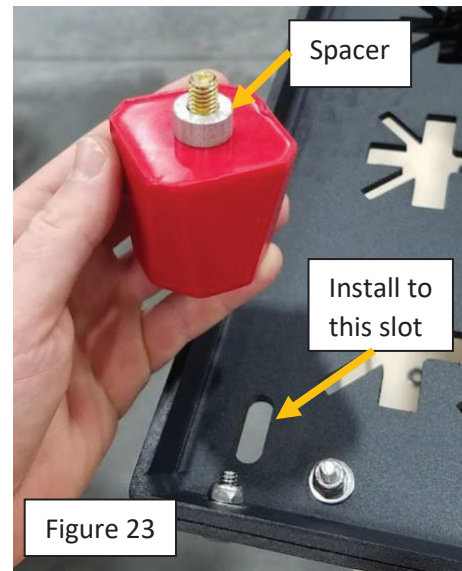

6. Retrieve driver's side rack (part A) and set face down on a support box with protective covering to allow for easy access to top and bottom faces of the rack. See figure 25.



7. Assemble the driver side upper hinge mount. This step is very similar to the passenger side upper hinge mount, refer to previous pictures as needed.
- Set (2) Nvader rack parts K onto the inside of the rack plate to align the slots in part K with the mounting holes in the upper section of the rack.
 - Align part H onto the outer z-fold area of the rack plate next to where the K parts were placed.
 - Install (8) $\frac{1}{4}$ "-20 x $\frac{3}{4}$ " SS black oxide carriage bolts with $\frac{1}{4}$ " SS washers and $\frac{1}{4}$ "-20 SS thin nylock nuts. Ensure the washers and nuts are located on the inside of the rack.
 - Using a $\frac{7}{16}$ " open end wrench, tighten the (2) nuts in the z-fold area. Make sure the square head of the carriage bolt is fully seated in the slot on the outside of the rack to prevent stripping out the slot. Keep pressure against the bolt head to keep it from backing out. Tighten with wrench by hand until tight and the bolt is fully engaged with the nylon lock on the nut.
 - Next, tighten the (2) bolts on the opposite end of bracket G with impact and $\frac{7}{16}$ " socket, again making sure the carriage bolt is fully seated in the slot on the rack to prevent stripping.
 - Tighten the last (4) nuts using same technique as in the previous step.
 - Cut approx. 1.5" of 1" foam tape and stick onto the upper hinge mount spacer.
8. Assemble the driver side lower hinge mount. This step is very similar to the passenger side lower hinge mount, refer to previous pictures as needed.
- Rotate the rack on the support box to access the lower hinge mount area.
 - Set part U onto part I so that the mounting slots align and the logo is right side up. Insert (1) $\frac{1}{4}$ "-20 x $\frac{3}{4}$ " SS black oxide carriage bolt through the front side.
 - Assemble parts U and I together to the lower right corner of the rack so the logo plate is on the front of the rack and the rest of the bracket extends past the bottom of the rack plate. Use (2) $\frac{1}{4}$ "-20 x $\frac{3}{4}$ " SS black oxide carriage bolts, (2) $\frac{1}{4}$ " SS washers and (2) $\frac{1}{4}$ "-20 SS thin nylock nuts. **NOTE: if the outer flange is bent to where you can not start the outer bolt, gingerly hammer with a dead blow hammer to get bracket to fit better to rack plate.**

- d. Assemble the remaining (3) bolts, washers and nuts to the lower hinge bracket. Make sure the two outermost bolts have the nuts located on the bottom of the bracket and the one innermost bolt has the bolt head on the bottom of the bracket as shown in figure .
 - e. Using an impact and 7/16" socket, tighten the (2) nuts on the outside bottom of the rack and bracket first while holding the logo plate and bracket flat against the rack face. Again, ensure carriage bolts are fully engaged into the slots to prevent stripping.
 - f. Next, use a 7/16" ratcheting wrench to tighten the nut on the inside corner of the rack while holding the logo plate flat against the bracket and slid all the way up in the slots.
 - g. Lastly, use an impact, 7/16" socket and 3" swivel extension to tighten the last nut on the inside corner of the rack.
 - h. Cut approx. 2" of 1" foam tape and install to the back side of the lower hinge mount bracket.
9. Assemble driver side center door mount
- a. Align part J with the left edge of the rack plate. Align the curvature of part J with the curvature of the rack plate.
 - b. Loosely assemble (7) ¼"-20 x ¾" SS black oxide carriage bolts, washers and nuts through part J and the rack plate. Ensure the bolt heads are on the front of the rack plate.
 - c. Align the slots in part J and the rack plate for mounting to the door, then use an impact and 7/16" socket to tighten the first nut down from the slots first as shown in figure 26.

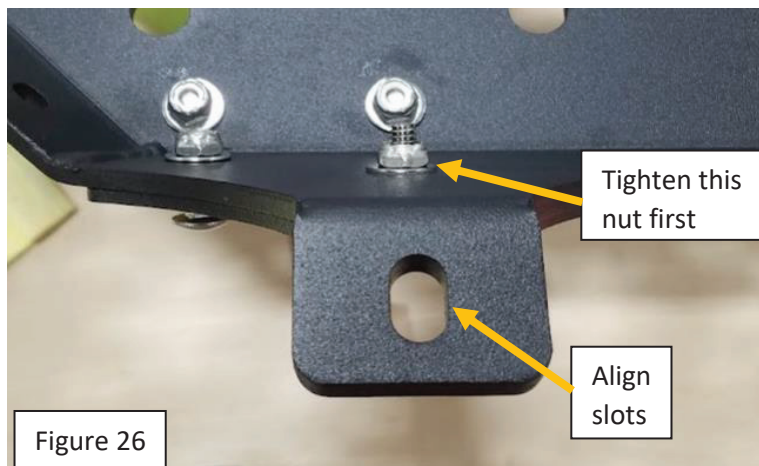

- d. Tighten remaining (6) nuts from the bottom end of the rack up to the door mount section using an impact. Ensure part J sits flush against the rack plate and that the carriage bolts do not strip out.
 - e. Place approx. 1.5" long strip of 1" foam tape across the door mounting section.
10. Install bumper spacer to driver side rack plate. This step is very similar to the passenger side bumper spacer mounting, refer to previous pictures as needed.
- a. Set 3/8" x 3/8" unthreaded aluminum spacer onto the stud of a 3/8" threaded-stud bumper spacer with Natural Red color then install to the slot in the lower inside corner of the rack plate. Ensure the bumper is on the inside of the rack.
 - b. Install a 3/8" SS black oxide flat washer and a 3/8"-16 SS Thin nylock nut to the bumper stud on the outside of the rack.
 - c. Tighten the nut using an impact and a 14mm socket until the nut is tight while also ensuring the stud threads protrude through the nylon lock on the nut.



NVADER RACK

ASSEMBLY INSTRUCTIONS