

CHEFMAN®

Countertop Classic

COMPACT MICROWAVE

USER GUIDE

- Safety Instructions
- Features
- Operating Instructions
- Troubleshooting
- Cleaning and Maintenance
- Terms and Conditions
- Warranty Registration

RJ55-7-TG

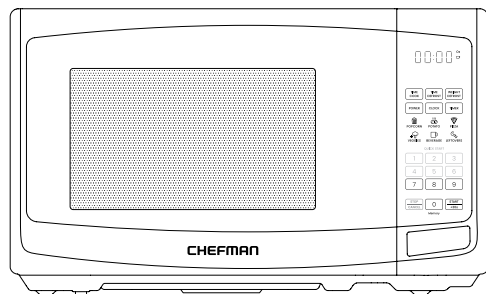

COOKING FORWARD™

Welcome!

Thank you for choosing the Countertop Classic Compact Microwave as the newest addition to your kitchen. Whether this is your first Chefman® appliance or you're already part of our family, we're happy to be cooking with you. For everything from simple one-touch heating to multi-phase cooking with different power levels, the microwave covers all your needs. It provides powerful, even heating, while its compact size makes it perfect for small spaces.

We know you're excited to get cooking, but please take a few minutes to read our directions, safety instructions, and warranty information.

From our kitchen to yours,
The Chefman® Team



READ ALL INSTRUCTIONS BEFORE USE

For your safety and continued enjoyment of this product, always read the instruction manual before using.

CONTENTS

- 4** Safety Instructions
- 10** Features
- 12** Operating Instructions
- 21** Troubleshooting
- 23** Cleaning and Maintenance
- 24** Terms and Conditions
- 26** Warranty Registration

SAFETY INSTRUCTIONS

IMPORTANT SAFEGUARDS

PRECAUTIONS TO AVOID POSSIBLE EXPOSURE TO EXCESSIVE MICROWAVE ENERGY

1. Do not attempt to operate this oven with the door open since this can result in harmful exposure to microwave energy. It is important not to disable or tamper with the safety interlocks.
2. Do not place any object between the oven front face and the door or allow soil or cleaner residue to accumulate on sealing surfaces.
3. Do not operate the oven if it is damaged. It is particularly important that the oven door closes properly and that there is no damage to the:
 - a. DOOR (bent)
 - b. HINGES AND LATCHES (broken or loosened)
 - c. DOOR SEALS AND SEALING SURFACE
4. The oven should not be adjusted or repaired. If the oven breaks, please contact Chefman® Customer Support for assistance.

Specifications

Model	RJ55-7-TG
Voltage	120V~, 60Hz
Power microwave	700W
Capacity	0.7 cu ft
External dimensions	17.3 x 13 x 10.2 in
Turntable diameter	10 in
Weight	20.2 lb

SAFETY INSTRUCTIONS

IMPORTANT SAFEGUARDS

To reduce the risk of burns, electrical shock, fire, injury to persons, or exposure to excessive microwave energy when using your oven, follow basic safety precautions, including:

1. Read all instructions before using the appliance.
2. Read and follow the specific “PRECAUTIONS TO AVOID POSSIBLE EXPOSURE TO EXCESSIVE MICROWAVE ENERGY” found on p. 4.
3. As with most cooking appliances, close supervision is necessary to reduce the risk of a fire in the oven cavity.
4. To reduce the risk of fire in the oven cavity:
 - a. Do not overcook food. Carefully attend the appliance when paper, plastic, or other combustible materials are used in the oven.
 - b. Remove wire twist ties and metal handles from paper or plastic containers or bags before placing them in the oven.
 - c. If materials inside the oven ignite, keep the oven door closed. Turn the oven off and unplug the appliance.
 - d. Do not use the oven cavity for storage purposes. Do not leave paper products, cooking utensils, or food in the cavity when not in use.
5. This oven must be grounded. Connect only to a properly grounded outlet. See “GROUNDING INSTRUCTIONS” on p. 8.
6. Install or locate this oven only in accordance with the installation instructions provided beginning on p. 12.

SAFETY INSTRUCTIONS

IMPORTANT SAFEGUARDS

7. Some products—such as whole eggs, sealed glass jars, and other sealed food containers—are liable to explode and should not be heated in the oven. Closed containers should be opened and plastic pouches should be pierced before cooking.
8. Use this appliance only for its intended uses as described in this manual. Do not use corrosive chemicals or vapors in this appliance. This oven is specifically designed to heat, cook, or dry food. It is not designed for industrial or laboratory use.
9. As with any appliance, close supervision is necessary when used by children.
10. Do not operate this oven if it has a damaged cord or plug, if it is not working properly, or if it has been damaged or dropped.
11. Do not attempt to service or repair this microwave. Instead, contact Chefman® Customer Support for assistance.
12. Do not cover or block any openings on the oven.
13. Do not store or use this appliance outdoors.
14. Do not use this oven near water, for example, near a kitchen sink, in a wet basement, near a swimming pool, or in similar locations.
15. Do not immerse the cord or plug in water.
16. Keep the cord away from heated surfaces.
17. Do not let the cord hang over the edge of a table or counter.

SAFETY INSTRUCTIONS

IMPORTANT SAFEGUARDS

18. When cleaning the oven, door, and sealing surfaces, use only mild, nonabrasive soaps or detergents applied with a sponge or soft cloth.
19. This appliance is for private household use only.
20. In a microwave, liquids such as water, coffee, or tea can become overheated beyond the boiling point without appearing to be boiling. Visible bubbling is not always present when the container is removed from the microwave oven. **THIS COULD RESULT IN VERY HOT LIQUIDS SUDDENLY BOILING OVER WHEN THE CONTAINER IS DISTURBED OR A SPOON OR OTHER UTENSIL IS INSERTED INTO THE LIQUID.**
 - a. Do not overheat liquids.
 - b. Stir liquids both before and halfway through heating them.
 - c. Do not use straight-sided containers with narrow necks.
 - d. After heating, allow the container to stand in the oven for a short time before removing it.
 - e. Use extreme care when inserting a spoon or other utensil into a container.

**FOR HOUSEHOLD USE ONLY
SAVE THESE INSTRUCTIONS**

SAFETY INSTRUCTIONS

IMPORTANT SAFEGUARDS

GROUNDING INSTRUCTIONS

DANGER

Electrical Shock Hazard

Touching some of the internal components can cause serious personal injury or death. Do not disassemble this appliance.

This appliance must be grounded. In the event of an electrical short circuit, grounding reduces the risk of electrical shock by providing an escape wire for the electric current. To protect against electrical shock, this appliance is equipped with a cord having a 3-prong grounding-type plug for insertion into a proper grounding-type electrical outlet. DO NOT alter the plug for use in a 2-prong outlet. If the plug will not fit into an outlet, have a proper outlet installed by a qualified electrician.

WARNING

Improper use of the grounding plug can result in electrical shock.

Consult a qualified electrician or serviceman if the grounding instructions are not completely understood or if doubt exists as to whether the appliance is properly grounded.

1. A short power-supply cord is provided to reduce the risks of entanglement or tripping over a longer cord.
2. Extension cords may be used if care is exercised in their use.

SAFETY INSTRUCTIONS

IMPORTANT SAFEGUARDS

3. If an extension cord is used:
 - a. The marked electrical rating of the cord set and/or the marked electrical rating of the extension cord should be at least as great as the electrical rating of the appliance.
 - b. The extension cord must be a 3-wire cord that has a 3-pronged grounding plug and a 3-slot receptacle to accept the appliance's plug.
 - c. The longer cord should be arranged so that it will not drape over a countertop or tabletop where it can be pulled on by children or tripped over unintentionally.

UTENSIL TEST

Certain nonmetallic utensils and containers may not be safe to use in the microwave. For more details on microwave-safe materials, refer to the chart beginning on p. 14. If in doubt, you can test the utensil or container with the following procedure:

1. Fill a microwave-safe container with 1 cup of cold water.
2. Place the water container and the empty container/utensil being tested on the glass turntable and microwave for 1 minute. Do not exceed the 1 minute cooking time.
3. Carefully feel the container or utensil. If the empty container or utensil is warm, do not use it in the microwave.

California Proposition 65:
(Applicable for California Residents only)



WARNING:
Cancer and Reproductive Harm -
www.P65Warnings.ca.gov.



Do not place the appliance on a stovetop or any other heatable surface, even if the stovetop is not on. Doing so is a fire hazard.

FEATURES

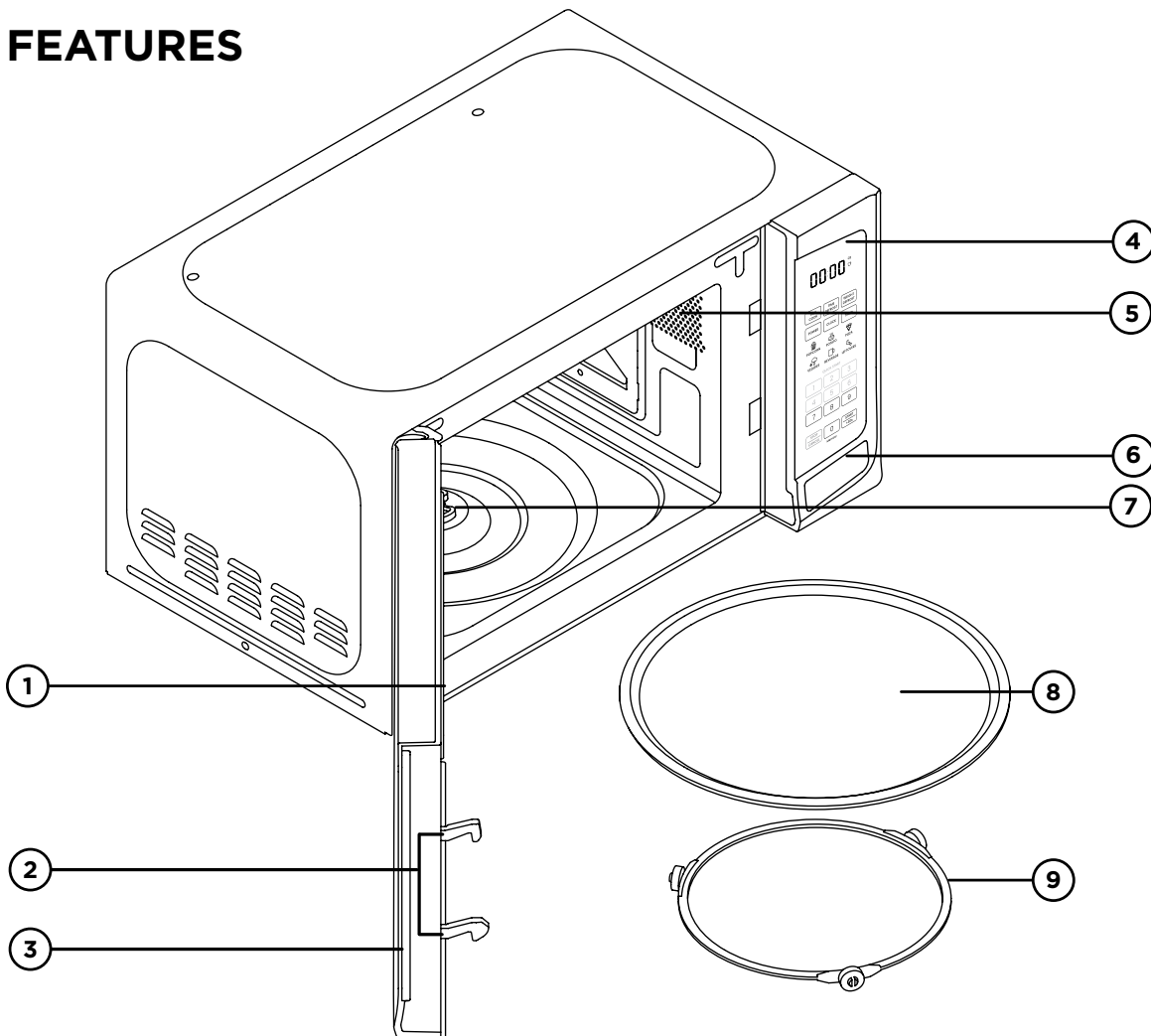

1. Door Assembly

2. Safety Interlock System

3. Window

4. Display

5. Interior Light

6. Door Release Button

7. Turntable Shaft

8. Glass Turntable

9. Turntable Support Ring

FEATURES

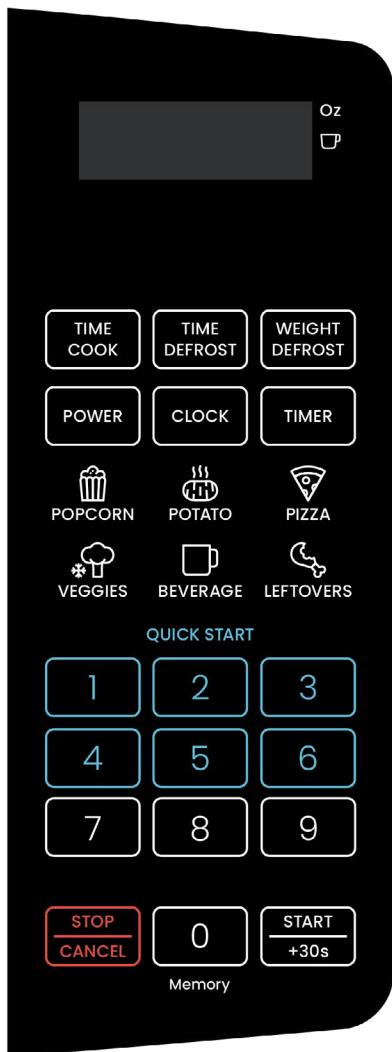

CONTROL PANEL

Clock/Timer Display Counts down to the end of an active cooking cycle. Displays time of day in Standby Mode.

TIME COOK Button Press to set cooking time.

DEFROST Buttons Press to defrost by time or by weight (see p. 17).

POWER Button Press to set power level from 0 to 10 (Default power is 100%).

CLOCK Button Press to set microwave's clock.

TIMER Button Press to set a timer for kitchen tasks (with no microwaving).

Preset Icons Use to select preset cooking functions for six popular foods (see p. 18).

Number Pad Use to manually enter cooking time or set clock or kitchen timer. Numbers 1 through 6 can also be used for 1-touch quick cooking (see p. 16).

STOP/CANCEL Button Use to stop active cooking or return to Standby Mode.

0/Memory Button The Number Pad's "0" button can also be used to program and select a stored favorite cooking cycle (see p. 19).

START/+30 SEC Button Use to start cooking after selecting a preset or entering time manually OR to add 30 seconds of cooking at any time.

OPERATING INSTRUCTIONS

BEFORE FIRST USE

1. Remove all packaging materials, and read and remove all removable stickers. (Leave the rating label on the unit.) Be sure that all parts and accessories are accounted for before throwing away any packaging.
2. Gently wipe the exterior and interior of the oven with a clean, damp cloth and dry thoroughly. Wash the interior with a mild liquid soap and a damp cloth or sponge.
NOTE: Do not use abrasive cleansers, like steel wool pads, as they may damage the finish. Never immerse the unit in water or other liquids.
3. Hand wash the glass turntable and dry thoroughly. (The turntable is also top-rack dishwasher safe.)
4. Install the microwave as directed below and install the turntable as directed on p. 13.

COUNTERTOP INSTALLATION

1. Place the microwave on a firm, level surface with the following clearance for intake and outtake openings:
 - right side of microwave must be open.
 - a minimum clearance of 3 inches between the other sides and any adjacent walls.
 - a minimum clearance of 12 inches between the top of the microwave and any upper cabinets.
 - the minimum installation height is 3 feet.

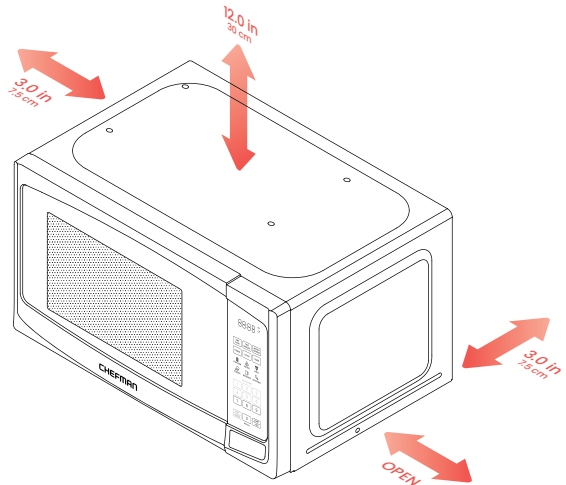

NOTE: Blocking openings can damage the oven.

OPERATING INSTRUCTIONS

2. Place the oven far away from radios and television sets, as the operation of the microwave oven may cause interference with radios or TVs. If there is still interference, it can be reduced by taking the following measures:
 - a. Clean the door and sealing surface of the oven.
 - b. Reorient the receiving antenna of the radio or television.
 - c. Plug the microwave oven into a different outlet so that the microwave oven and receiver are on different branch circuits.
3. Plug your oven into a standard household outlet. Be sure the voltage and the frequency are the same as the voltage and the frequency on the rating label. **WARNING:** Do not install the oven over a range cooktop or other heat-producing appliance. If installed near or over a heat source, the oven could be damaged, and the warranty would be void.
4. This device complies with part 18 of the FCC rules.

TURNTABLE INSTALLATION

Both the glass turntable and the turntable support must be used whenever you operate the oven.

1. Set the turntable support in the oven interior so the wheels make contact with the oven floor.
2. Place the glass turntable over the support, aligning the hub on the underside of the turntable with the turntable shaft in the oven floor. Never place the turntable upside down.
3. Always place food and food containers on the turntable for cooking. **NOTE:** If the turntable or turntable support cracks or breaks, contact Chefman® Customer Support.

OPERATING INSTRUCTIONS

MATERIALS YOU CAN AND CAN'T USE IN THE OVEN

Material	Can Use in the Oven?	Notes
Dinnerware	Yes, microwave-safe only	Refer to manufacturer's label and/or instructions. Do not use cracked or chipped dishes.
Glass jars	Yes	Always remove lid. Use to heat food only until just warm. Most glass jars are not heat-resistant and may break.
Glassware	Yes, heat-resistant only	Make sure there is no metallic trim. Do not use cracked or chipped glassware.
Paper oven-cooking bags	Yes	Follow manufacturer's instructions. Do not close with metal twist ties. Make slits to allow steam to escape.
Plastic bags	Yes, microwave-safe only	Follow manufacturer's instructions. "Boiling bags" and tightly closed plastic bags should be slit, pierced, or vented as directed by package.
Aluminum foil	No	May cause arcing.
Paper plates and cups	Yes	Use for short-term cooking/warming only. Do not leave oven unattended while cooking.
Paper towels	Yes	Use with supervision for a short-term cooking only. Use to cover food while reheating to prevent splatter and absorb fat.
Parchment paper	Yes	Use as a cover to prevent splattering or a wrap for steaming.
Wax paper	Yes	Use as a cover to prevent splattering and retain moisture.

OPERATING INSTRUCTIONS

MATERIALS YOU CAN AND CAN'T USE IN THE OVEN (continued)

Material	Can Use in the Oven?	Notes
Plastic wrap	Yes, microwave-safe only	Use to cover food containers during cooking to retain moisture. Do not allow plastic wrap to touch food.
Plastic containers	Yes, microwave-safe only	Check manufacturer's label and instructions. Some plastic containers soften as the food inside gets hot.
Thermometer	Microwave-safe only	Check manufacturer's label and instructions.
Browning dish	Yes, microwave-safe only	Follow manufacturer's instructions. The bottom of the browning dish must be at least 3/16 inch (5mm) above the turntable. Incorrect usage may cause the turntable to break.
Aluminum trays	No	May cause arcing. Transfer food to a microwave-safe dish.
Food carton with metal handle	No	i.e., Chinese takeout carton. May cause arcing. Transfer food to a microwave-safe dish.
Metal twist ties	No	May cause arcing and could cause a fire in the oven.
Paper bags	No	May cause a fire in the oven.
Plastic foam (Styrofoam)	No	May melt or contaminate food when exposed to high temperatures.
Wood	No	Will dry out and may catch fire when used in the microwave oven.

OPERATING INSTRUCTIONS

SETTING THE CLOCK

To set the clock to the time of day, press the CLOCK button once; "00:00" will display. Then use the number keypad to enter the current time. Press CLOCK again to finish. When the microwave is actively cooking, you can press CLOCK to display the current time for 3 seconds.

TO USE THE QUICK-COOK FUNCTIONS

Use the Quick-Cook buttons for simple, one-touch microwaving at 100% power.

1. Open the door and place your food on the turntable in a microwave-safe vessel.
2. Press any of the keypad numbers 1 through 6 to instantly begin cooking for that number of minutes (e.g., press 3 to start cooking for 3 minutes). There is no need to press the START button.
3. To add time during cooking, press +30 SEC (same as the START button) as many times as needed.
4. For even shorter cooking cycles, you can simply press the +30 SEC button to instantly begin cooking for 30 seconds. Add additional time during cooking by pressing the +30 SEC button as needed.
5. After the timer finishes counting down, the unit will beep five times.

TO MICROWAVE IN MANUAL MODE

Use the Manual Microwave Mode for simple, timed microwaving, either at full power or at lower power levels.

1. Open the door and place your food on the turntable in a microwave-safe vessel.
2. Press TIME COOK, and use the keypad to enter the cooking time.
3. If desired, press POWER to adjust the power level from 0 to 10 (if you do not select a power level, the microwave defaults to level 10/full power). **NOTE:** If power level 0 is selected, the fan will operate without heating. You can use this setting to clear odors from the microwave.

OPERATING INSTRUCTIONS

4. Press START. The unit will begin cooking and counting down.
5. While the unit is operating, press the +30 SEC button at any time to add 30 seconds of cooking time at the current power level. Pressing the STOP/CANCEL button OR opening the door pauses the cooking and the timer countdown. Pressing START once the door is closed will resume cooking. Pressing the STOP/CANCEL button a second time when the unit is paused will return the oven to Standby Mode.
6. After the timer finishes counting down, the unit will beep five times. If you wish to add 30 more seconds at full power, simply press the +30 SEC button.
7. **Multiphase Cooking:** If you want to cook at two different power levels, you can program the microwave all at once. After entering the first cooking time and power level, instead of pressing START, simply enter a second cooking time and power level in the same way. Then press START, and the microwave will cook the first cycle, followed immediately by the second cycle. During cooking, you can press POWER to check what power level the microwave is currently using.

TO DEFROST

You can defrost frozen foods either by weight or by time using the Manual Microwave Mode for simple, timed microwaving, either at full power or at lower power levels.

1. Open the door and place your food on the turntable in a microwave-safe vessel.
2. Press the WEIGHT DEFROST button, then use the keypad to enter the ounce weight of your food (from 4 to 100 oz). Alternatively, press the TIME DEFROST button and use the keypad to enter your desired defrosting time (from 1 second to 99 minutes, 99 seconds).
3. Default power for defrosting is level 3/30%. If you wish to adjust it, press POWER, then use the keypad to enter your preferred power level (1-10).
4. Press START. The unit will begin defrosting and counting down.
5. After the timer finishes counting down, the unit will beep five times.

OPERATING INSTRUCTIONS

TO USE PRESET FUNCTIONS

The preset functions make it quick and easy to program the oven for cooking some popular foods.

1. Open the door and place your food on the turntable in a microwave-safe vessel.
2. Press one of the preset icons and continue pressing that button to toggle through the size/quantity choices that appear on the display (the menu reflects only the relevant choices for your chosen preset). See the chart below for more information on the preset functions.
3. Press START. The unit will begin cooking and counting down.
4. After the timer finishes counting down, the unit will beep five times.

PRESET FUNCTION CHART

Preset Name	Size/Quantity Options	Notes
Popcorn	1.75 oz, 3 oz, 3.5 oz	Choose closest size if your packet does not match one of the size options.
Potato	1, 2, 3 count	Based on whole potatoes, approx. 8 oz each (prick skin with a fork first).
Pizza	4 oz, 8 oz, 14 oz	Reflects time to reheat cold slices.
Veggies	4 oz, 8 oz, 16 oz	Reflects time to defrost and cook frozen vegetables.
Leftovers	9 oz, 12 oz, 18 oz	Reflects time to reheat refrigerated leftovers.
Beverage	1 cup, 2 cups, 3 cups	Reflects time to reheat a beverage (measured in 120mL cups) that has cooled to room temperature.

OPERATING INSTRUCTIONS

TO USE THE FAVORITES FUNCTION

You can program up to three favorite cooking cycles (for instance, 5 minutes and 30 seconds at 50% power) to be stored in memory and activated with one touch.

1. **To program:** Press the "0" button on the keypad once (press it twice to program a second favorite cycle).
2. Press TIME COOK, then enter the cooking time using the keypad (e.g., "5-3-0" for 5 minutes and 30 seconds).
3. Press POWER, then enter your power level, from 1 to 10 (e.g., press 5 for 50% power).
4. Press START to save the setting. The unit will beep and display "1" on the screen (or "2" or "3" if this is your second or third favorite saved).
5. **To use the saved favorite:** Press the "0/Memory" button on the keypad once and the screen will display "1" (or to select an already-programmed second favorite, press the button twice; the screen will display "2"; for a third favorite, press the button three times; the screen will display "3"). Press START and cooking will begin.

OPERATING INSTRUCTIONS

OTHER FUNCTIONS

Timer

The built-in kitchen timer gives you a timer at your fingertips for all sorts of tasks that don't use the microwave. To use it, press the TIMER button, set the desired time, and press START (Maximum time is 99 minutes and 99 seconds). When the timer ends, the microwave will beep 5 times. **NOTE:** The timer does not start or stop the microwave oven, and the oven cannot be used to cook when the timer is in use.

Safety Lock

To put the unit in childproof Lock Mode, press and hold the STOP/CANCEL button for 3 seconds. The unit will give a long beep. In Lock Mode the screen displays as , and the microwave cannot be started. To turn off the Lock Mode, press and hold the STOP/CANCEL button for 3 seconds again.

TROUBLESHOOTING

If you encounter problems with your oven, refer to the chart below for possible causes and solutions. If you continue to have trouble, please contact Chefman® Customer Support.

Problem	Possible Cause	Solution
Oven will not start	<ul style="list-style-type: none"> a. Electrical cord for oven is not plugged in. b. Door is open. c. Wrong operation is set. 	<ul style="list-style-type: none"> a. Plug into a three-prong outlet. b. Close the door and try again. c. Check instructions.
Arcing or sparking while oven is running	<ul style="list-style-type: none"> a. Wrong materials used in the microwave. b. The oven is operated while empty. c. Spilled food remains in the oven interior. 	<ul style="list-style-type: none"> a. Refer to chart on p. 14 for materials you can and can't use in the microwave. b. Do not operate the oven while empty. c. Clean the interior with a damp cloth.
Unevenly cooked food	<ul style="list-style-type: none"> a. Wrong materials used in the microwave. b. Cooking time and power level are not suitable. c. Food is not flipped or stirred. 	<ul style="list-style-type: none"> a. Refer to chart on p. 14 for materials you can and can't use in the microwave. b. Use correct cooking time and power level. c. Flip or stir food midway through cooking cycle.
Overcooked food	<ul style="list-style-type: none"> a. Cooking time is too long or power is too high. 	<ul style="list-style-type: none"> a. Reduce cooking time and/or power.

TROUBLESHOOTING

Problem	Possible Cause	Solution
Undercooked food	<ul style="list-style-type: none">a. Cooking time is too short or power is too low.b. Food is not completely defrosted.c. Wrong materials used in microwave.d. Oven ventilation ports are restricted.	<ul style="list-style-type: none">a. Increase cooking time and/or power.b. Completely defrost food before cooking.c. Refer to chart on p. 14 for materials you can and can't use.d. Move unit so there is ample space around ventilation ports (see p. 12).
Incompletely or unevenly defrosted food	<ul style="list-style-type: none">a. Defrosting time is too short or power is too low.b. Wrong materials used in microwave.c. Food is not flipped or stirred.	<ul style="list-style-type: none">a. Increase defrosting time and/or power.b. Refer to chart on p. 14 for materials you can and can't use.c. Flip or stir food midway through defrosting cycle.

CLEANING & MAINTENANCE

Periodically wipe down the interior of the microwave with a damp cloth.

If food splatters on the interior or on the glass turntable, clean both with mild soap and a damp cloth. The turntable is also top-rack dishwasher safe.

Do not immerse the unit in water. The unit and turntable support are not dishwasher safe.

TERMS AND CONDITIONS

Limited Warranty

RJ Brands, LLC d/b/a Chefman® offers a limited 1-year Warranty (the “Warranty”) available on sales through authorized distributors and retailers only. Please note that this Warranty becomes valid from the date of initial retail purchase and that the Warranty is non-transferable and applies only to the original purchaser.

This Warranty is void without proof of purchase within the United States and Canada. Please be aware that this Warranty supersedes all other warranties and constitutes the entire agreement between the consumer and Chefman®. Any changes to the Terms and Conditions of this Warranty must be in writing, signed by a representative of Chefman®. No other party has the right or ability to alter or change the Terms and Conditions of this Warranty.

We may ask you to please submit, via email, photos and/or video of the issue you are experiencing. This is to help us better assess the matter and possibly offer a quick fix. Photos and/or video may also be required to determine Warranty eligibility.

We encourage you to register your product. Registering can make the Warranty process easier and can keep you informed of any updates or recalls on your product. To register, follow the directions on the Chefman® Warranty Registration page in the Chefman® User Guide. Please retain your proof of purchase even after registering. In the event that you do not have proof of your purchase date, we may declare your Warranty void or we may, at our sole discretion, apply the date of manufacture as the purchase date for purposes of this Warranty.

TERMS AND CONDITIONS

Limited Warranty

WHAT THE WARRANTY COVERS

- **Manufacturer Defects** – Chefman® products are warranted against defects in material and workmanship, under normal household use, for a period of 1 year from the date of purchase when used in accordance with the directions listed in the Chefman® User Guide. If your product does not work as it should, please contact Customer Support at support@chefman.com so that we may assist you.

THIS WARRANTY DOES NOT COVER

- **Misuse** – Damage that occurs from neglectful or improper use of products, including, but not limited to, damage that occurs as a result of usage with incompatible voltage, regardless of whether the product was used with a converter or adapter. See Safety Instructions in the Chefman® User Guide for information on proper use of product;
- **Poor Maintenance** – General lack of proper care. We encourage you to take care of your Chefman® products so that you may continue to enjoy them. Please see Cleaning and Maintenance directions in the Chefman® User Guide for information on proper maintenance;
- **Commercial Use** – Damage that occurs from commercial use;
- **Normal Wear and Tear** – Damage or degradation expected to occur due to normal use over time;
- **Altered Products** – Damage that occurs from alterations or modifications by any entity other than Chefman® such as the removal of the rating label affixed to the product;
- **Catastrophic Events** – Damage that occurs from fire, floods, or natural disasters; or
- **Loss of Interest** – Claims of loss of interest or enjoyment.

CHEFMAN® WARRANTY REGISTRATION

What do I need to register my product?

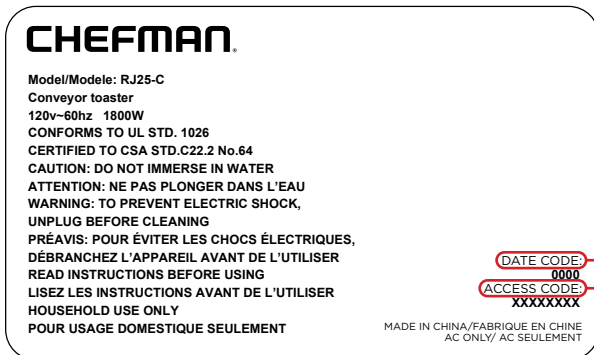

- Contact Information
- Model Number
- Proof of Purchase (online confirmation, receipt, gift receipt)
- Date Code
- Access Code

NOTE: Label depicted here is an example.

How do I register my product?

All you need to do is fill out a simple Chefman® registration form. You can easily access the form in one of the two ways listed below:

1. Visit Chefman.com/register.
2. Scan the QR code to access site:

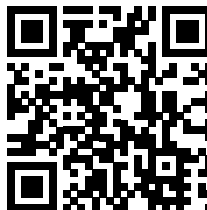

CHEFMAN® WARRANTY REGISTRATION

For product information, visit Chefman.com.

EXCEPT WHERE SUCH LIABILITY IS REQUIRED BY LAW, THIS WARRANTY DOES NOT COVER, AND CHEFMAN® SHALL NOT BE LIABLE FOR, INCIDENTAL, INDIRECT, SPECIAL, OR CONSEQUENTIAL DAMAGES, INCLUDING WITHOUT LIMITATION, DAMAGE TO, OR LOSS OF USE OF THE PRODUCT, OR LOST SALES OR PROFITS OR DELAY OR FAILURE TO PERFORM THIS WARRANTY OBLIGATION. THE REMEDIES PROVIDED HEREIN ARE THE EXCLUSIVE REMEDIES UNDER THIS WARRANTY, WHETHER BASED ON CONTRACT, TORT OR OTHERWISE.

Chefman® is a registered trademark of RJ Brands, LLC.
Cooking Forward™ is a trademark of RJ Brands, LLC.

CHEFMAN®

@mychefman



www.chefman.com

©CHEFMAN 2023