

CHEFMAN®

ESPRESSO MAKER

USER GUIDE

- Safety Instructions
- Features
- Operating Instructions
- Troubleshooting
- Cleaning and Maintenance
- Terms and Conditions
- Warranty

RJ54

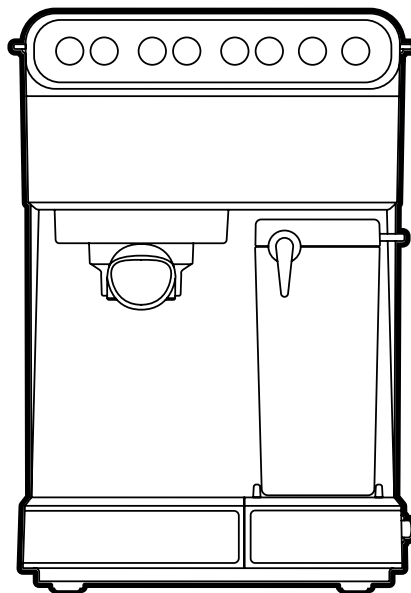

COOKING FORWARD™

Welcome!

Whether this is your first Chefman® appliance or you're already part of our family, we're happy to be in the kitchen with you. With your new Espresso Maker, you can save time money while learning to be your own barista. Whether you're craving an espresso, cappuccino, or latte—the Espresso Maker has you covered with one-touch presets that brew the perfect cup. You can also make your own customized coffee drink with the easy-to-use integrated milk frother.

We know you're excited to start brewing, but please take a few minutes to carefully read our directions, safety instructions, and warranty information.

From our kitchen to yours,

The Chefman® Team



READ ALL INSTRUCTIONS BEFORE USE
For your safety and continued enjoyment of this product, always read the instruction manual before using.

CONTENTS

- 1 Safety Instructions**
- 5 Features**
- 7 Operating Instructions**
- 16 Troubleshooting**
- 17 Cleaning and Maintenance**
- 21 Terms and Conditions**
- 23 Warranty**

SAFETY INSTRUCTIONS

IMPORTANT SAFEGUARDS

WARNING: When using electrical appliances, basic safety precautions should always be followed to reduce the risk of fire, electric shock, and/or injury to persons including the following:

1. Read all instructions.
2. Do not touch hot surfaces. Use handles or knobs.
3. To protect against electric shock, do not place cord, plugs, or appliance in water or other liquid.
4. Close supervision is necessary when any appliance is used by or near children.
5. Unplug from outlet when not in use and before cleaning. Allow to cool before putting on or taking off parts, and before cleaning the appliance.
6. Do not operate any appliance with a damaged cord or plug or after the appliance malfunctions, or has been damaged in any manner. In such cases, contract Chefman Customer Support.
7. The use of an accessory not evaluated for use with this appliance may cause injuries.

SAFETY INSTRUCTIONS

IMPORTANT SAFEGUARDS

8. Do not use outdoors.
9. Do not let cord hang over edge of table or counter or touch hot surfaces.
10. Do not place on or near a hot gas or electric burner, or in a heated oven.
11. Always attach plug to appliance first, then plug cord into the wall outlet. To disconnect, turn any control to the off position, then remove plug from wall outlet.
12. Do not use appliance for other than intended use.

SAVE THESE INSTRUCTIONS

SAFETY INSTRUCTIONS

IMPORTANT SAFEGUARDS

WARNING: This appliance has a polarized plug (one blade is wider than the other). This plug is intended to fit into a polarized outlet only one way. If the plug does not fit fully into the outlet, reverse the plug. If it still does not fit, contact a qualified electrician. Do not attempt to modify the plug in any way or force it into the outlet. This could result in injury or electric shock.

SHORT CORD INSTRUCTIONS

A short power supply cord is provided to reduce the hazards of entanglement or tripping over a longer cord. Longer detachable power-supply cords or extension cords are available and may be used if care is exercised in their use. If a longer detachable power-supply extension cord is used:

1. The marked electrical rating of the extension cord should be at least as great as the electrical rating of the appliance.
2. The cord should be arranged so that it will not drape over the countertop or tabletop where it can be pulled on by children or tripped over.

SAFETY INSTRUCTIONS

IMPORTANT SAFEGUARDS

POWER CORD SAFETY TIPS

1. Never pull or yank on cord or the appliance.
2. To insert plug, grasp it firmly and guide it into outlet.
3. To disconnect appliance, grasp plug and remove it from outlet.
4. Before each use, inspect the power cord for cuts and/or abrasion marks. If any are found, this indicates that the appliance should be serviced, and the power cord replaced. Please contact Chefman® Support for assistance.
5. Never wrap the cord tightly around the appliance, as this could place undue stress on the cord where it enters the appliance and cause it to fray and break.

DO NOT OPERATE APPLIANCE IF THE POWER CORD SHOWS ANY DAMAGE OR IF APPLIANCE WORKS INTERMITTENTLY OR STOPS WORKING ENTIRELY.

*California Proposition 65:
(Applicable for California Residents only)*



WARNING:

Cancer and Reproductive Harm -
www.P65Warnings.ca.gov.



Do not place the appliance on a stovetop or any other heatable surface.

FEATURES

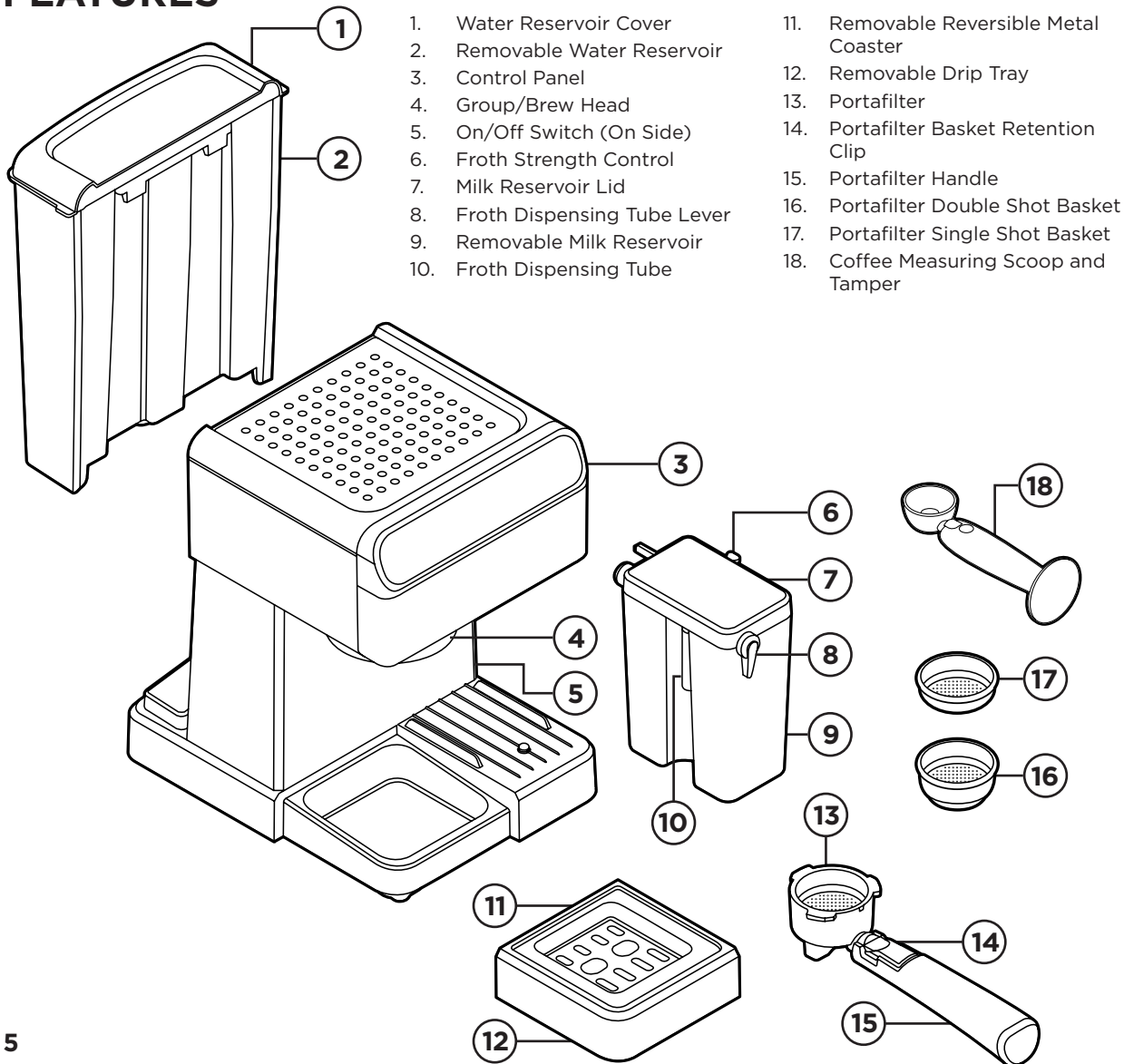

FEATURES

CONTROL PANEL

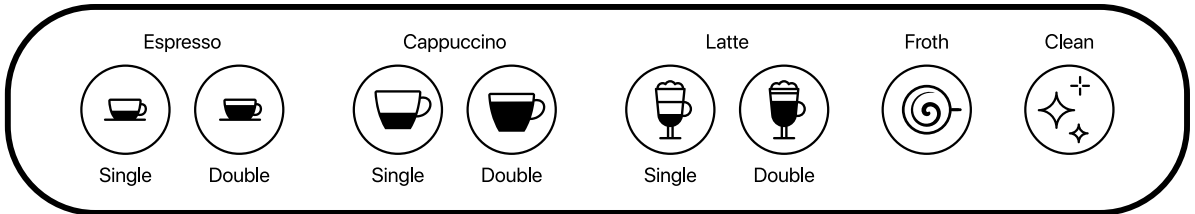

- When the power button (located on the side of the unit) is switched on, the unit will be in standby mode. The unit will automatically begin preheating, all available functions on the display will light, and the unit will automatically begin preheating. (**NOTE:** If the milk reservoir is not on the unit, only the Single and Double Espresso buttons will display.)
- When you make your drink selection, only that button will remain illuminated, and it will blink during the remaining preheating time. (Do not press the button again or that will cancel your selection.)
- Your selected drink button will turn solid when preheating has finished and the brew drink cycle has begun.
- When the brew cycle is complete, the unit will beep three times; all buttons will light up and the unit will be return to standby mode. If no longer using the espresso machine, you may wish to turn it off.
- After 20 minutes of no action, the unit will go into sleep mode, and just the CLEAN icon (not the text) will be lit. Press the CLEAN icon to wake the unit up.
- When the FROTH button is pressed, the froth function will run for 30 seconds. (All other function lights will turn off.) You can end frothing before 30 seconds by pressing the FROTH button again.

OPERATING INSTRUCTIONS

BEFORE FIRST USE

1. Remove all packaging materials and check to ensure that all parts and accessories are accounted for. Read all stickers and remove ones that are not permanent.
2. Remove and hand wash the water reservoir, the milk reservoir, the portafilter, portafilter baskets, measuring scoop, drip tray, and removable coaster with a mild detergent and water. Rinse and dry well. Only the metal baskets and coaster are top-rack dishwasher safe. All other parts are NOT dishwasher safe.
3. Before first use, you must prime the unit (clean and remove any packaging debris) according to the directions below.

IMPORTANT-PRIME THE UNIT BEFORE FIRST USE

To prime the unit, follow these steps:

1. Fill the water reservoir to between the “Min” and “Max” markings on the tank.
2. Remove the milk reservoir. (Tilt it up first, then pull out.) Fill the milk reservoir with water (not milk) to between the “Min” and “Max” markings on the tank and return it to unit. (To insert it, tilt down and push it firmly into place.)
3. Place a large heatproof cup or mug on the metal coaster set over the drip tray. (Note the coaster is reversible to make the height adjustable.)
4. Use the silver froth tube lever to position the froth dispensing tube inside the cup.
5. Place an empty portafilter basket in the portafilter.
6. Fit the portafilter onto the brew head unit, being sure it’s locked in place. (See p. 11 for more information on placing the portafilter.)
7. Plug in the unit and turn it on. (The power button is located on the side toward the bottom.)

OPERATING INSTRUCTIONS

8. Press the DOUBLE CAPPUCCINO button.
9. The button will blink as the unit preheats; do not press the button again or you will cancel the function.
10. Let the cup fill with water from the brew head and from the froth dispensing tube. When the brew cycle function ends, the unit will beep three times. Carefully dispose of the water in the cup and in the milk reservoir. The unit is now primed and ready for use.

CHOOSE THE RIGHT SIZE CUP

With 15 bars of pressure, the Espresso Maker allows for a wide variety of coffee drinks from a tiny espresso to a large latte. See the graph below to choose the right size cup. Be aware that the actual amount will vary depending on such variables as the coffee grind and froth amount. Note that you can flip the metal coaster over the drip tray over to change the height of the cup under the brew head.

DRINK	SHOTS	VOLUME (APPROX.)
Espresso	Single	1.75 oz
Espresso	Double	3.25 oz
Cappuccino	Single	3.5 oz
Cappuccino	Double	6.25 oz
Latte	Single	5.75 oz
Latte	Double	10 oz

OPERATING INSTRUCTIONS

CHOOSE THE RIGHT THE COFFEE AND GRIND

For best results, use freshly ground espresso beans as pre-ground beans lose their flavor fast. The grind should be fine, like table salt. If the grind is too fine (it will feel powdery when rubbed between fingers), the water will not flow through even under pressure. If the grind is too coarse, the water will flow through too fast, resulting in a weak flavor. Finding your preferred grind may take some practice.

HOW TO FILL THE WATER RESERVOIR

To fill the reservoir with water, you may either use a jar to fill it while on the unit or remove it from the unit and to fill it up at the sink. Open the lid and fill the reservoir with the desired amount of cold water between the “Min” and “Max” markings on the tank. Never use warm or hot water to fill the water reservoir. Close the water reservoir lid and place it back in the unit, if necessary, ensuring it fits tightly in place.

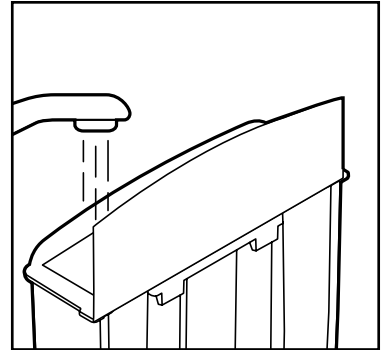

HOW TO FILL THE MILK RESERVOIR

If you plan to prepare cappuccino or latte, you will need to fill the milk reservoir; it can be left empty or even off the unit for espresso.

To remove the milk reservoir from the unit, tilt it up before pulling it out. Fill it with cold milk to between the “Min” and “Max” markings on the tank. To put the milk reservoir back on the unit, tilt it down before sliding it firmly back into place.

NOTE: You can use any type of milk—whole, skim, soy, oat—to make froth.

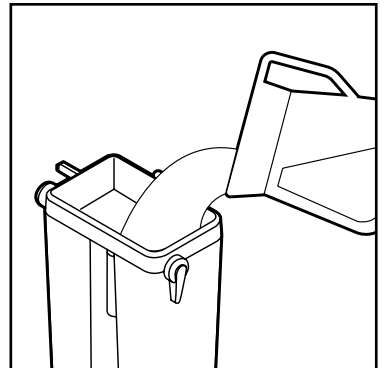

OPERATING INSTRUCTIONS

HOW TO CHOOSE AND INSERT THE PORTAFILER BASKET

To insert the basket into the portafilter, simply drop the basket into it.

Use the smaller basket for a single shot of espresso.

Use the larger basket for either when making a larger size drink or to have a double dose of espresso in a smaller size drink or.

HOW TO PACK THE PORTAFILTER WITH COFFEE

1. Use the coffee measuring spoon to fill the basket with finely ground espresso beans (do not overfill).
2. Using the tamper end of the measuring spoon, press on the grinds firmly and evenly. Be sure the surface is smooth and flat.
3. Clean any excess grinds from the rim of the portafilter to ensure proper fit in the brew head.

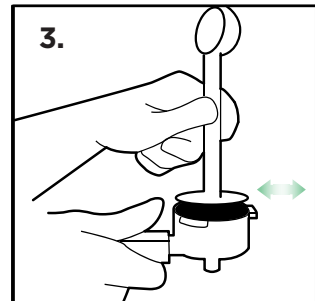
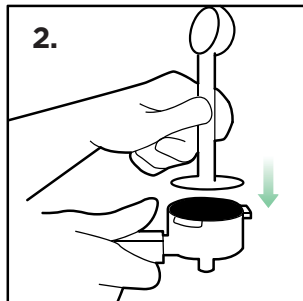
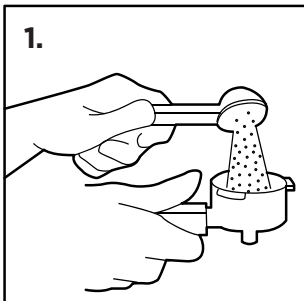

OPERATING INSTRUCTIONS

HOW TO PLACE THE PORTAFILTER ON THE BREW HEAD

1. Position the portafilter underneath the brew head with its handle facing to the left.
2. Insert the portafilter up into the brew head, lining up handle with the open lock icon on the unit.
3. Slowly turn the handle to the right until resistance is felt and the handle is aligned with the locked icon on the unit; the handle will be at an approximate 90° angle to the machine.

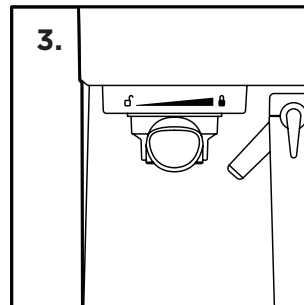
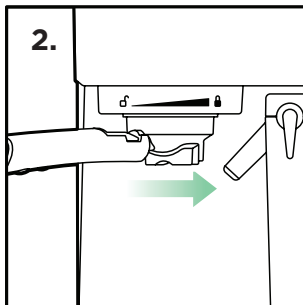
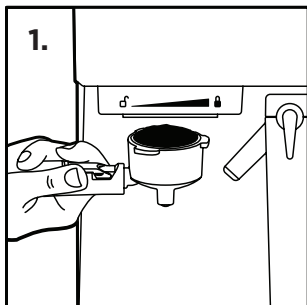

CAUTION: To avoid possible burns to body parts and/or other injury from hot steam and water or damages to the unit, never remove the water reservoir or the portafilter while your espresso/cappuccino maker is brewing coffee or frothing. If you intend to make a second cup of coffee, be sure the unit is in standby mode—all buttons will be lit and solid—before removing or inserting portafilter. If you need to add more water or milk to the reservoirs, switch off the unit by pressing the button on the side of the unit.

OPERATING INSTRUCTIONS

HOW TO MAKE AN ESPRESSO

Espresso is a unique method of coffee brewing in which hot water is forced through finely ground coffee beans for a richer and more full-bodied brew than regular drip. Because of its strength, espresso is usually served in small (1 1/2 to 2 oz) portions in demitasse cups.

1. Make sure the unit is plugged in.
2. Turn the unit on by pressing the power button located on the side of the unit.
3. Fill the water reservoir as directed on p. 9.
4. Fill the portafilter with finely ground coffee beans and attach it to the brew head as directed on p. 10 and p. 11.
5. Place a heatproof cup or demitasse on the metal coaster over the drip tray.
6. Choose to brew a single or double espresso by pressing the appropriate button. The button will blink to signify the unit is preheating. The button will turn solid during the brew cycle. When brewing is complete, the unit will beep three times, and your espresso will be ready to enjoy.
7. When the brew cycle ends, the unit will go into standby mode and will be preheating in the background. If no button is pressed within 20 minutes, it will go in to sleep mode.
8. To discard spent grinds, remove the portafilter and let it cool. Hold the portafilter basket in place by flipping up the portafilter basket retention clip to partially cover the lip of the basket and portafilter. Press on the clip with your thumb to hold the basket in place as you empty the grinds.

OPERATING INSTRUCTIONS

HOW TO MAKE A CAPPUCCINO

A cappuccino is a delicious beverage made with equal parts espresso, steamed milk, and froth. When using the cappuccino presets, there is no need to manually froth the milk; it will occur automatically.

1. Make sure the unit is plugged in.
2. Turn the unit on by pressing the power button located on the side of the unit.
3. Fill the water reservoir as directed on p. 9.
4. Fill the milk reservoir with milk between the “Min” and “Max” lines and insert it onto the unit. (If the milk reservoir is not on the unit, the cappuccino function will not work.)
5. Choose the amount of froth by moving the froth strength control to the right for more froth and to the left for less.
6. Place a heatproof cup or mug on the metal coaster over the drip tray.
7. Use the silver froth tube lever to position the froth dispensing tube over the cup.
8. Fill the portafilter with ground coffee and attach it to the brew head as directed on p. 10 and p. 11.
9. Choose whether to brew a single or double cappuccino by pressing the appropriate button. The button will blink to signify the unit is preheating. The button will turn solid during the brew cycle. When brewing is complete, the unit will beep three times, and your cappuccino will be ready to enjoy
10. When the brew cycle ends, the unit will go into standby mode and will be preheating in the background. If no button is pressed within 20 minutes, it will go in to sleep mode.

OPERATING INSTRUCTIONS

11. To discard spent grinds, remove the portafilter and let cool. Hold the portafilter basket in place by flipping up the portafilter basket retention clip to partially cover the lip of the basket and portafilter. Press on the clip with your thumb to hold the basket in place as you empty the grinds. **NOTE:** Be sure to clean the froth dispensing tube after every use following the directions on p. 18.

HOW TO MAKE A LATTE

A latte is a larger coffee drink made with mostly steamed milk and a little espresso. When using the latte presets, there is no need to manually froth the milk; it will occur automatically.

1. Make sure unit is plugged in.
2. Turn unit on by pressing the power button located on the side of the unit.
3. Fill water reservoir as directed on p. 9.
4. Fill the milk reservoir with milk to between the “Min” and “Max” lines and insert it into the unit. (If the milk reservoir is not on the unit, the latte function will not work.)
5. Choose the amount of froth by moving the froth strength control to the right for more froth and to the left for less.
6. Place a large heatproof cup or mug on the metal coaster over drip tray. **NOTE:** Be sure to use a large mug, especially with a double latte, which can yield as much as 10 oz.
7. Use the silver froth tube lever to position the froth dispensing tube over the cup.
8. Fill the portafilter with ground coffee and attach it to the brew head as directed on p. 10 and p. 11.
9. Choose whether to brew a single or double latte by pressing the appropriate button. The button will blink to signify the unit is preheating. The button will turn solid during the brew cycle. When brewing is complete, the unit will beep three times, and your latte will be ready to enjoy.

OPERATING INSTRUCTIONS

10. When the brew cycle ends, the unit will go into standby mode and will be preheating in the background. If no button is pressed within 20 minutes, it will go in to sleep mode.
11. To discard spent grinds, remove the portafilter and let cool. Hold the portafilter basket in place by flipping up the portafilter basket retention clip to partially cover the lip of the basket and portafilter. Press on the clip with your thumb to hold the basket in place as you empty the grinds. **NOTE:** Be sure to clean the froth dispensing tube after every use following the directions on p. 18.

HOW TO ADD MORE FROTH OR FROTH MILK SEPARATELY

The Espresso Maker also allows you to add more frothed milk to your coffee drink and to prepare froth milk on its own to use to make a macchiato or to add to hot chocolate. Be sure the cup is positioned with the froth dispensing tube over it, then simply press the FROTH button. The milk will froth for about 30 seconds. If you want less time, simply press the FROTH button again to stop frothing.

NOTE: Be sure to clean the froth dispensing tube after every use following the directions on p. 18.

TROUBLESHOOTING

PROBLEM	POSSIBLE CAUSES	SOLUTIONS
Coffee does not come out	<ol style="list-style-type: none"> 1. Appliance not turned on or plugged in 2. No water in reservoir. 3. Coffee is ground too fine. 4. Too much coffee in filter basket 5. Coffee has been tamped down too much 	<ol style="list-style-type: none"> 1. Plug in unit and turn it on 2. Add water 3. Grind less fine 4. Add less coffee 5. Refill filter and tamp less
Coffee comes out around the edge of the portafilter	<ol style="list-style-type: none"> 1. Portafilter not rotated to full lock position 2. Coffee grounds were left around the filter basket rim 3. Too much coffee in filter basket 	<ol style="list-style-type: none"> 1. Rotate portafilter to locked position 2. Wipe off rim 3. Fill with less coffee
Milk is not foamy after frothing or is not coming out of tube	<ol style="list-style-type: none"> 1. Ran out of steam 2. Milk is not cold enough 3. Frothing tube is blocked 	<ol style="list-style-type: none"> 1. Ensure there is enough water in the reservoir 2. Chill milk and frothing reservoir 3. Follow the instructions to clean the milk reservoir and the frothing tube
Coffee comes out too quickly	<ol style="list-style-type: none"> 1. Coffee grind is too coarse 2. Not enough coffee in filter 	<ol style="list-style-type: none"> 1. Use a finer grind 2. Add more coffee
Coffee is too weak	<ol style="list-style-type: none"> 1. Using single filter basket for double shot 2. Coffee grind is too coarse 	<ol style="list-style-type: none"> 1. Use double filter basket for double shot 2. Use a finer grind

CLEANING AND MAINTENANCE

HOW TO CLEAN THE PORTAFILTER AND BREW HEAD

NOTE: This method of cleaning is useful if you make espresso only. If you make cappuccino or latte or use the milk frothing tube separately, you can clean both the brew head, portafilter, and frothing tube all at the same time following the directions starting at the bottom of p. 18.

1. Before cleaning, turn off the unit and unplug it. Some of the metal parts might still be hot. Do not touch them with your hands until they have cooled.
2. If not already out, remove the portafilter and discard the used coffee grounds. To hold the basket in place while emptying grinds, flip up the portafilter basket retention clip and hold it down with your thumb as you empty the basket.
3. Rinse the basket and portafilter with warm soapy water and rinse well. Single and double shot baskets are top-rack dishwasher safe, but the portafilter is not.
4. Wipe the underside of the brew head with a damp cloth or paper towel to remove any coffee grounds that might have been left behind

CLEANING AND MAINTENANCE

HOW TO CLEAN THE MILK RESERVOIR AND FROTHING TUBE

1. Remove the milk reservoir from the unit (tilt it up before pulling it out). Transfer any remaining milk to another container and refrigerate.
2. Wash the milk reservoir and its lid thoroughly with warm soapy water. Rinse well. Do not use abrasive cleaners and scouring pads, as they will scratch the finish. The milk reservoir is NOT dishwasher safe.
3. Attach the portafilter with an empty basket in it to the brew head in the unit.
4. Place a large empty cup under the brew head and be sure there is water in the water reservoir.
5. Add fresh water to the milk reservoir and return it to the unit.
6. Use the silver froth tube lever to position the froth dispensing tube over the cup.
7. Press the CLEAN button.
8. After the cycle ends, dispose of the water in the mug and any water left in the milk and water reservoirs.

HOW TO CLEAN THE WATER RESERVOIR

It is recommended to empty the water reservoir between uses. Discard the remaining water by removing the reservoir emptying it into the sink. Wash the water reservoir as needed with soapy water, rinse it well and wipe it dry. The water reservoir is NOT dishwasher safe.

CLEANING AND MAINTENANCE

HOW TO CLEAN THE HOUSING AND STORE THE UNIT

1. Wipe the housing with a soft wet cloth. Do not use abrasive cleaners or scouring pads, as they can scratch the finish. **CAUTION:** Do not immerse appliance, cord, or plug in water.
2. Do not store the portafilter in the brew head. This can adversely affect the seal between the brew head and the porta-filter while brewing espresso.
3. Decalcify the unit as needed according to directions on p. 20.

HOW TO DEACIFY

Mineral deposits built-up in the unit will affect the operation of the appliance.

Your appliance must be decalcified when you notice an increase in the time required to brew espresso, or when there is excessive steaming. Also, you may notice a build-up of white deposits on the surface of the brew head. The frequency of cleaning depends upon the hardness of you water.

TO DEACIFY INTERNAL PARTS:

1. Be sure unit is cool, off, and unplugged.
2. Fill the water reservoir with white vinegar to between the “Min” and “Max” markings on the tank. Fill the milk reservoir with water and slide it into unit.
3. Put a large cup or jar on the drip tray and position the froth dispensing tube in the cup.

CLEANING AND MAINTENANCE

4. Insert the portafilter with an empty basket in it into the brew head.
5. Plug in the unit and turn it on.
6. Press the CLEAN button
7. Repeat Steps 1-6 as necessary using only fresh water to rinse any remaining traces of vinegar out of the machine.

HOW TO DECALFIFY THE WATER RESERVOIR

1. Fill the water reservoir with fresh, undiluted white vinegar.
2. Let sit for at least 8 hours; reservoir may be placed on unit for this time.
3. Discard vinegar then rinse the water reservoir thoroughly with fresh water.

TERMS AND CONDITIONS

Limited Warranty

Our products are backed by a limited 1-year warranty. To register, follow the instructions on the Chefman® Warranty Registration page in this User Guide.

We offer a limited 1-year warranty from the date of purchase. This warranty is void without proof of purchase within the USA, Canada, or Mexico. Service centers and retail stores do not have the right to alter or change the Terms and Conditions of this warranty.

WHAT THE WARRANTY COVERS

- **Manufacturer Defects**

Chefman® products are warranted against defects in material and workmanship for a period of 1 year from the date of purchase when used in accordance with the Chefman® User Guide.

- **Qualified Replacements**

If your product does not work as it should, we will send you a new one. If the product is no longer available, we will replace it with one that is comparable.

TERMS AND CONDITIONS

Limited Warranty

THIS WARRANTY DOES NOT COVER

- **Misuse** - Damage that occurs from neglectful or improper use of products; damage that occurs as a result of usage with incompatible voltage. See Safety Instructions for information on proper use.
- **Poor Maintenance** - General lack of proper care. See Cleaning and Maintenance for information on proper maintenance.
- **Commercial Use** - Damage that occurs from commercial use.
- **Altered Products** - Damage that occurs from alterations or modifications by any entity other than Chefman®; removal of rating label.
- **Catastrophic Events** - Damage that occurs from fire, floods, or natural disasters.
- **Loss of Interest** - Claims of loss of interest or enjoyment.

CHEFMAN® WARRANTY REGISTRATION

Register your product to add an additional 3 months to your warranty.

What do I Need to Register my Product

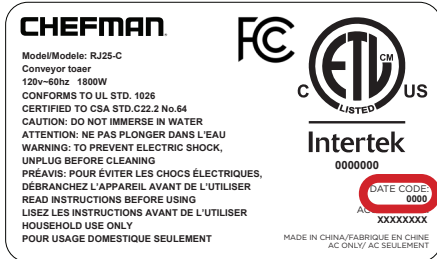

- Contact Information
- Model Number
- Proof of Purchase
(online confirmation, receipt, gift receipt)
- Date code

NOTE: Label depicted here is an example.

How Do I Register my Product?

We offer two convenient ways to access the Chefman® registration form:

1. Visit chefman.com/register.
2. Scan the QR code below to access site:

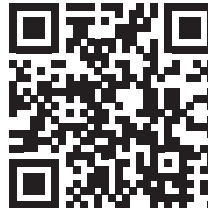

CHEFMAN® WARRANTY REGISTRATION

For product information, visit chefman.com

OTHER LIMITATIONS: ALL WARRANTIES OF ANY KIND WHATSOEVER, EXPRESS, IMPLIED AND STATUTORY, ARE HEREBY DISCLAIMED. ALL IMPLIED WARRANTIES OF MERCHANTABILITY AND FITNESS FOR A PARTICULAR PURPOSE ARE HEREBY DISCLAIMED, PROVIDED THAT IF ANY IMPLIED WARRANTIES OF ANY KIND IS REQUIRED BY ANY JURISDICTION, INCLUDING MERCHANTABILITY AND FITNESS FOR A PARTICULAR PURPOSE, THE DURATION OF SUCH IMPOSED IMPLIED WARRANTY IS LIMITED TO ONE (1) YEAR. THIS WARRANTY DOES NOT COVER, AND CHEFMAN® SHALL NOT BE LIABLE FOR, INCIDENTAL, INDIRECT, SPECIAL OR CONSEQUENTIAL DAMAGES, INCLUDING WITHOUT LIMITATION, DAMAGE TO, OR LOSS OF USE OF THE PRODUCT, OR LOST SALES OR PROFITS OR DELAY OR FAILURE TO PERFORM THIS WARRANTY OBLIGATION. THE REMEDIES PROVIDED HEREIN ARE THE EXCLUSIVE REMEDIES UNDER THIS WARRANTY, WHETHER BASED ON CONTRACT, TORT OR OTHERWISE.

This Warranty gives you specific legal rights, and you may also have other rights that vary from state to state or province to province. Some states or provinces do not allow the exclusions or limitations set forth in this Warranty, so the above limitations or exclusions may not apply to you depending on the jurisdiction of purchase.

Chefman® is a registered trademark of RJ BRANDS, LLC.

Cooking Forward™ is a trademark of RJ BRANDS, LLC.

Intertek® is a registered trademark of Intertek Group, PLC.

CHEFMAN®

@mychefman



www.chefman.com

©CHEFMAN 2020