

CHEFMAN®

TURBOFRY® AIR FRYER

This is your one-stop guide to using your product. From the below links, you can jump ahead to a specific document if desired.

QUICK LINKS

- [Quick Start Guide](#)
- [User Guide](#)

RJ38-SQ-45TDC

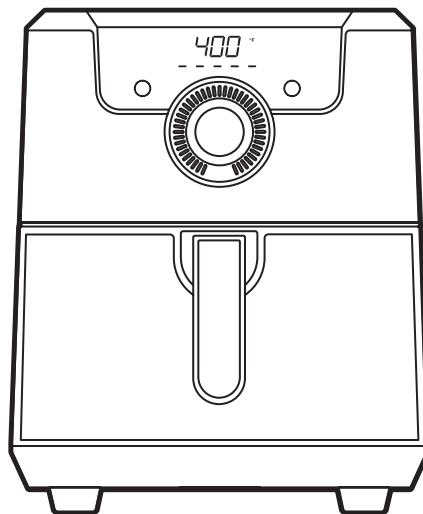

QUICK START GUIDE

BEFORE FIRST USE

1. Remove all packaging materials, such as plastic bags and foam inserts. Read and remove any stickers on unit except for rating label on bottom, which should remain on unit.
2. Check to ensure that all parts and accessories are accounted for.
3. Wipe down the interior and exterior with a damp cloth.
4. Wash the basket and basket rack with warm, soapy water. Dry thoroughly.
5. Read all directions and safety information in User Guide.

WHAT'S IN THE BOX

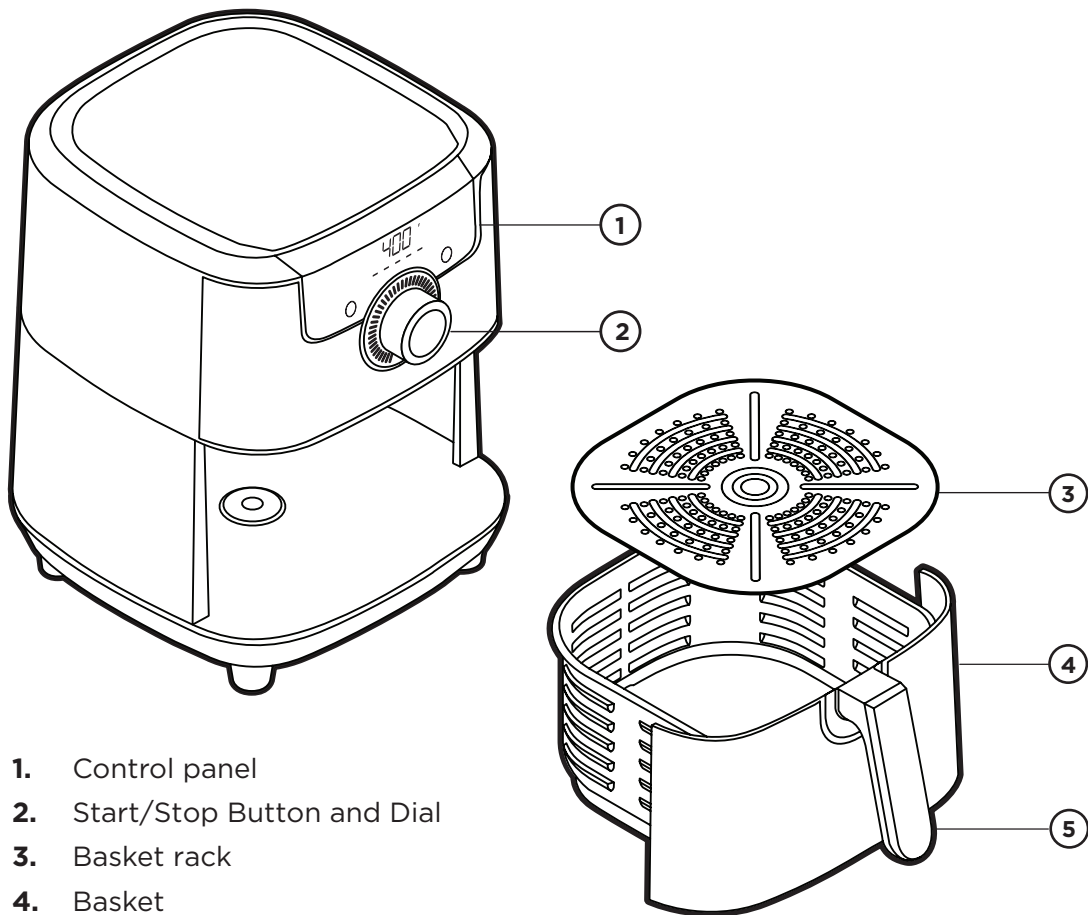

HOW TO COOK IN THE TURBOFRY® AIR FRYER

STEP 1

Prepare the food(s) you plan to air fry.

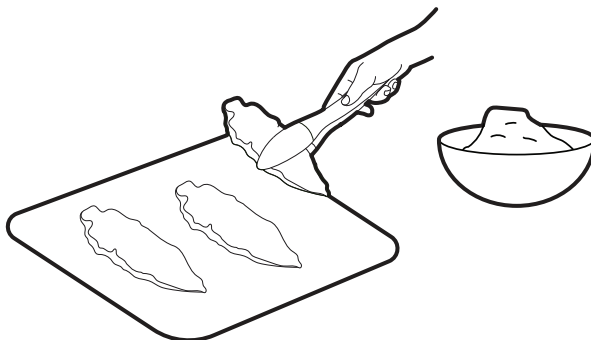

STEP 2

Set the air fryer on a hard, flat surface and plug it in.

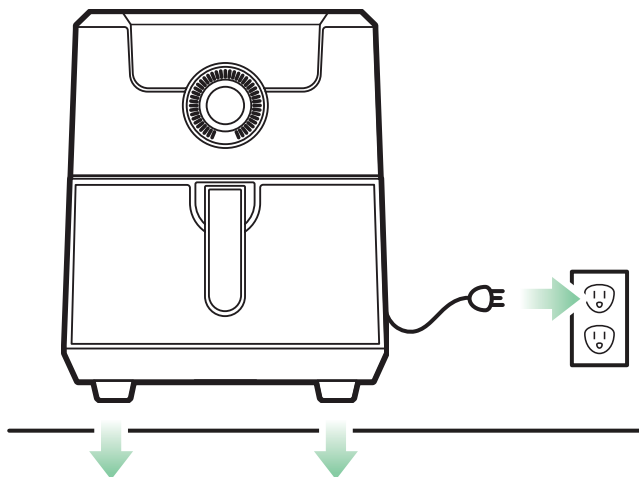

STEP 3

Insert rack into basket. Put food on rack, then slide basket into the air fryer.

CAUTION:

Never fill the basket with oil.

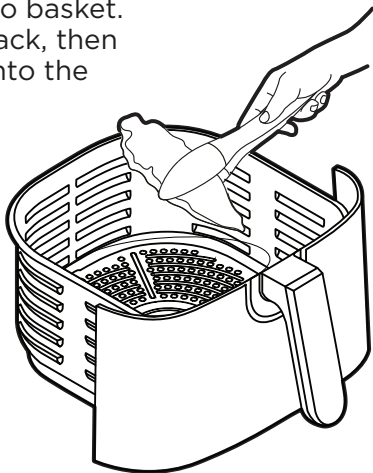

STEP 4

Set time and temperature as desired or use pre-set cooking parameters, then press Start.

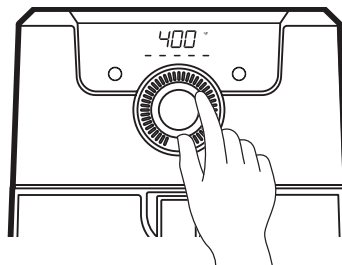

STEP 5

When Shake light comes on, remove the basket to check on, turn, or shake foods.

When the timer is done, remove the basket from the air fryer. Check food for doneness and serve.

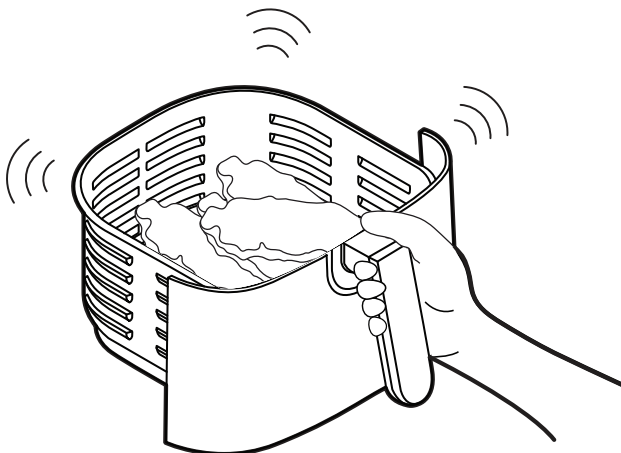

CLEANING AND MAINTENANCE

1. Unplug unit and cool completely before cleaning.
2. Wash the basket and rack with warm soapy water, rinse, and dry well with a towel for best results. Basket and rack are also top-rack dishwasher-safe.
3. Wipe down the outside and the inside of the unit, including the heating coil, with a damp cloth as needed. Do not put the unit in the dishwasher or submerge in water or any other liquid.
4. Do not use abrasive cleansers on basket, rack, exterior, or interior, or you could damage the finishes.

USER GUIDE

COOKING FORWARD™

Welcome!

Whether this is your first Chefman® appliance purchase or you're already part of our family, we're happy to be cooking with you! With your new TurboFry® Air Fryer you can air fry foods to crisp perfection with little to no oil for healthier eating. Plus, the fryer's sleek square design and stainless-steel accents means it'll look great in your kitchen.

We know you're excited to get cooking, but please take a few minutes to read our directions, safety instructions, and warranty information.

From our kitchen to yours,

The Chefman® Team



READ ALL INSTRUCTIONS BEFORE USE
For your safety and continued enjoyment of this product, always read the instruction manual before using.

CONTENTS

- 1 Safety Instructions**
- 7 Features**
- 9 Operating Instructions**
- 12 Air Fryer Cooking Tips**
- 13 Troubleshooting FAQs**
- 14 Cleaning and Maintenance**
- 16 Notes**
- 17 Terms and Conditions**
- 19 Warranty**

SAFETY INSTRUCTIONS

IMPORTANT SAFEGUARDS

This appliance is for **HOUSEHOLD USE ONLY**.

WARNING: When using electrical appliances, basic safety precautions should always be followed including the following:

1. Read all instructions.
2. Do not touch hot surfaces. Use handles or knobs.
3. To protect against electrical shock do not immerse cord or plug in water or other liquid.
4. Close supervision is necessary when any appliance is used by or near children.
5. Unplug from outlet when not in use and before cleaning. Allow to cool before putting on or taking off parts.
6. Do not operate any appliance with a damaged cord or plug or after the appliance malfunctions or has been damaged in any manner. Contact Chefman® Customer Service.

SAFETY INSTRUCTIONS

IMPORTANT SAFEGUARDS

7. The use of accessory attachments not recommended by the appliance manufacturer may cause injuries.
8. Do not use outdoors.
9. Do not let cord hang over edge of table or counter, or touch hot surfaces.
10. Do not place on or near a hot gas or electric burner, or in a heated oven.
11. Extreme caution must be used when moving an appliance containing hot oil or other hot liquids.
12. To disconnect, turn any control to “off,” then remove plug from wall outlet.
13. Do not use appliance for other than intended use.
14. Place the unit on a flat, sturdy, heat resistant surface. Do not place the unit near or on any type of heat source, such as a gas or electric burner, stove or oven. Do not use near an open flame or flammable materials.
15. The unit will emit some heat. Allow sufficient space around the unit when in use and do not place near other items or appliances.

SAFETY INSTRUCTIONS

IMPORTANT SAFEGUARDS

16. Check that your home power supply corresponds with the intended voltage of the TurboFry® Air Fryer.
17. Never wrap the cord tightly around the appliance during use or storage; this may cause the wire to fray and break.
18. This product is not a deep fryer. It is NOT meant to be filled with oil. Never fill any parts of the air fryer with oil. If you choose to use oil, toss food with oil in a separate bowl and then transfer food to the removeable racks or basket.
19. Do not leave uncooked ingredients in the air fryer for more than a short period of time before cooking; raw meat, poultry, fish, fruits and vegetables can spoil.
20. Do not move the TurboFry® Air Fryer while it is full of food.
21. Do not move the unit during use. During initial use, you may notice some smoke and/or a slight odor. This is normal and should quickly dissipate. It should not happen after the appliance has been used a few more times.
22. Do not leave the air fryer unattended during use.

SAFETY INSTRUCTIONS

IMPORTANT SAFEGUARDS

23. Some areas do get HOT during use and touch screen may get warm. Do not touch the heating elements. Do not place hands or other body parts near the air vents while air fryer is in use; burns may result. Take caution when handling the hot air fryer rack and all removable parts.
24. Use protective mitts and/or tongs to remove hot food from the air fryer.
25. Store the air fryer in a cool, dry place.

SAVE THESE INSTRUCTIONS

SAFETY INSTRUCTIONS

IMPORTANT SAFEGUARDS

WARNING: This appliance has a polarized plug (one blade is wider than the other). This plug is intended to fit into a polarized outlet only one way. If the plug does not fit fully into the outlet, reverse the plug. If it still does not fit, contact a qualified electrician. Do not attempt to modify the plug in any way or force it into the outlet. This could result in injury or electric shock.

SHORT CORD INSTRUCTIONS

A short power supply cord is provided to reduce the hazards of entanglement or tripping over a longer cord. Longer detachable power-supply cords or extension cords are available and may be used if care is exercised in their use. If a longer detachable power-supply extension cord is used:

1. The marked electrical rating of the extension cord should be at least as great as the electrical rating of the appliance.
2. The cord should be arranged so that it will not drape over the countertop or tabletop where it can be pulled on by children or tripped over.

SAFETY INSTRUCTIONS

IMPORTANT SAFEGUARDS

POWER CORD SAFETY TIPS

1. Never pull or yank on cord or the appliance.
2. To insert plug, grasp it firmly and guide it into outlet.
3. To disconnect appliance, grasp plug and remove it from outlet.
4. Before each use, inspect the power cord for cuts and/or abrasion marks. If any are found, this indicates that the appliance should be serviced, and the power cord replaced. Please contact Chefman® Support for assistance.
5. Never wrap the cord tightly around the appliance, as this could place undue stress on the cord where it enters the appliance and cause it to fray and break.

DO NOT OPERATE APPLIANCE IF THE POWER CORD SHOWS ANY DAMAGE OR IF APPLIANCE WORKS INTERMITTENTLY OR STOPS WORKING ENTIRELY.

*California Proposition 65:
(Applicable for California Residents only)*



WARNING:

Cancer and Reproductive Harm -
www.P65Warnings.ca.gov.



Do not place the appliance on a stovetop or any other heatable surface.

FEATURES

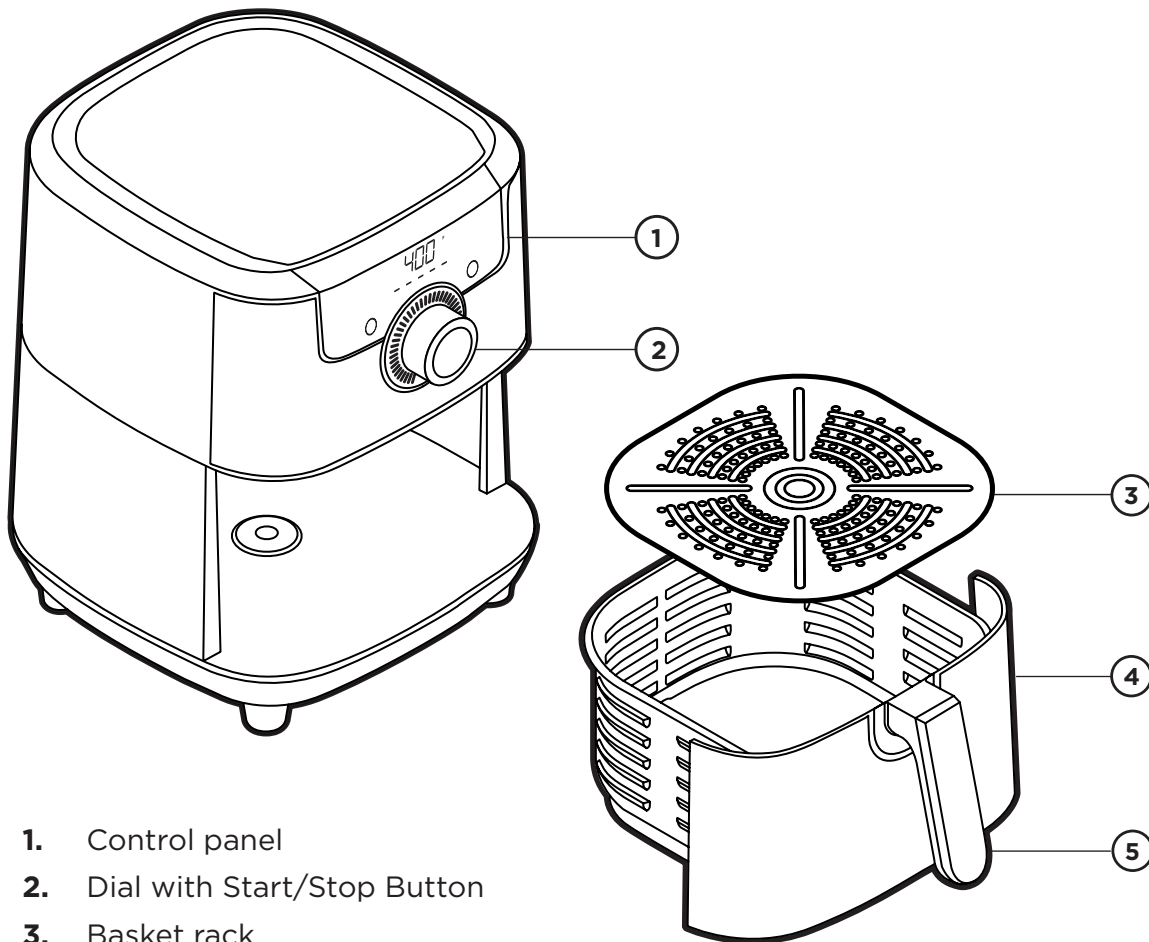

1. Control panel
2. Dial with Start/Stop Button
3. Basket rack
4. Basket
5. Basket handle

FEATURES

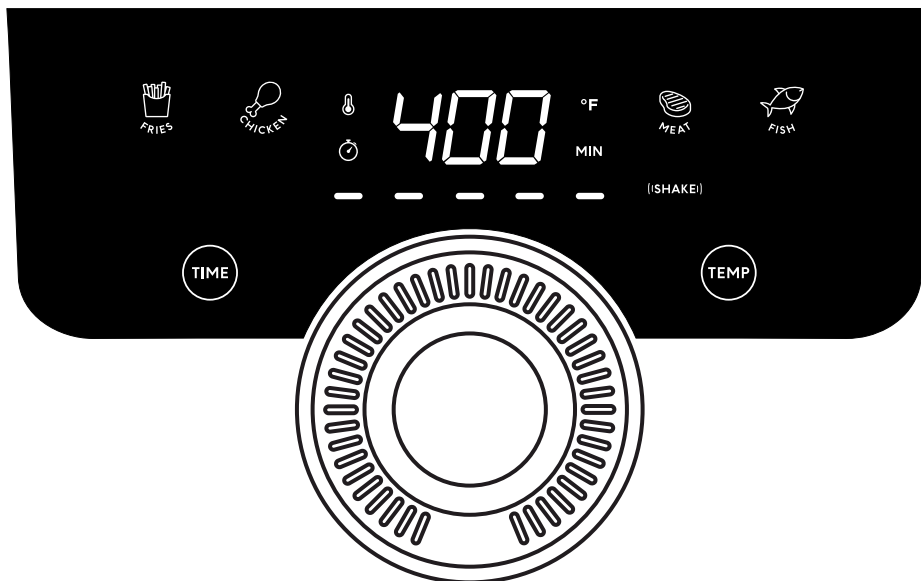

CONTROL PANEL:

Temperature/Time Display - Automatically alternates between the two

Dial - Turn left to lessen time and lower temperature; turn right to increase time and temperature settings

Start/Stop Button in center of dial - Press to begin or end cooking

Temp - Sets temperature between 200°F and 400°F

Time - Sets time (up to 1 hour)

Shake - Timed reminder to shake basket if desired

Blinking Dashes - Signifies unit is cooking

Food Pre-Set Icons - Sets suggested time and temperature for favorite foods (see Chart on p. 9)

FEATURES

FUNCTION	Default Time	Default Temp	Shake Timing
Air Fry (Manual)	15 min.	400°F	If time is set for less than 30 min., “Shake” light comes on halfway through. If over 30, every 15 min.
Meat	18 min.	375°F	“Shake” light comes on halfway through.
Chicken	22 min.	375°F	“Shake” light comes on halfway through.
Fish	10 min.	350°F	“Shake” light comes on halfway through.
Fries	20 min.	400°F	“Shake” light comes on every 5 min.

NOTE: Because food sizes can vary, do not rely on recipe timing only. Check foods for doneness against current safety guidelines before serving.

OPERATING INSTRUCTIONS

BEFORE FIRST USE

For best results, follow these steps before using your TurboFry® Air Fryer for the first time.

1. Remove all packaging materials, such as plastic bags and foam inserts.
2. Read and remove any stickers on unit except for rating label on bottom, which should remain on unit.
3. Check to ensure that all parts and accessories are accounted for.
4. Wipe down the interior and exterior with a damp cloth.
5. Wash the basket and basket rack with warm, soapy water. Dry thoroughly.

NOTE: On first use, unit may emit a slight odor, which is normal and will dissipate with use.

OPERATING INSTRUCTIONS

HOW TO COOK IN THE TURBOFRY® AIR FRYER

The air fryer's high-speed fan cooks your favorite foods quickly. The wire rack in the basket allows air to circulate around foods for even cooking and crisping and lets excess fat to drip down and away from foods for healthier eating.

CAUTION: Never fill the basket with oil. Unlike deep fryers, air fryers require little to no oil to produce a crisp texture. If you choose to use oil, toss foods with just a little in a separate bowl before cooking in the air fryer.

1. Prepare the food(s) you plan to air fry.
2. Place the air fryer on a hard, flat surface and plug it in. The control panel will illuminate, and the default temperature and time will alternate on the display.
3. Pull out basket. Insert basket rack, aligning the arrow on the rack with the arrow on the inside of the basket. (For easiest handling of the basket rack, pinch center grip bar with thumb and index finger.)

CAUTION: Never spray basket or rack with cooking oil from an aerosol spray can, which includes harsh components that can cause chipping of the nonstick coating. However, you can oil the tray or spray it with oil from a non-aerosol mister.

4. Put food on fry rack. Do not let food surpass the MAX line embossed on the basket.
5. Slide basket into the Air Fryer.

OPERATING INSTRUCTIONS

6. Set time and temperature as desired or use pre-set cooking parameters.

To set temperature, press TEMP and then turn the dial to add or subtract five degrees at a time. To set time (up to 1 hour), press TIME and turn dial to add or subtract time in 1-minute increments.

If cooking with pre-set cooking parameters: Choose the icon that best represents the food you're cooking and press the icon. This will set the pre-programmed time and temperature (see CHART on p. 9 for details).

7. Press Start. The fan will come on and animated dashes will display across the control panel indicating the unit is heating.

NOTE: During cooking, you can remove the basket to check on, turn, or shake foods. When you return the basket to the unit, the timer and heating will resume where it left off.

8. During cooking, the Shake light on the control panel will turn on and the air fryer will beep as a reminder to shake (or flip) foods as necessary. (See Function Chart on p. 9 for more details on timing.) The Shake light will turn off immediately when the basket is removed and will go off automatically after about 15 seconds if basket is not pulled out. (If your food does not need to be shaken, flipped, or turned, simply ignore the warning.)
9. When the timer is done, the air fryer will turn off automatically. Remove the basket from the air fryer. Check food for doneness, then carefully transfer food to plates or a platter and serve.

NOTE: On first use, unit may emit a slight odor, which is normal and will dissipate with use.

AIR FRYER COOKING TIPS

- **Preheat the air fryer for 5 minutes before cooking.** While not necessary, preheating the unit will cook foods faster and promote crisp results. If unit is cold, add a few minutes to your expected cooking time. **CAUTION:** Be careful when adding food after preheating as inside of fryer will be hot.
- **For a crisp exterior, oil foods lightly.** Some foods, especially if fresh, benefit from being tossed with a little oil in a separate bowl before frying. However, high-fat foods like a well marbled steak, or prepared foods usually require no additional oil.
- **Avoid wet batters.** Loose batters, such as those used for deep frying, do not work in air fryers, as the batter simply slides off. Adapt such recipes to give foods a thicker coating, preferably including breadcrumbs to help the coating adhere.
- **Use medium-high to high heat for most cooking.** Most foods will fry best between 325°F and 400°F. For gentler cooking and reheating, use a lower temperature to avoid overcooking.
- **Don't overcrowd the basket.** Too much food, especially if tightly packed, can inhibit browning and crisping. A better bet: Fry food in batches.
- **Shake the basket during cooking for even cooking.** A good shake is especially beneficial for smaller items like french fries, onion rings, and chicken wings. For larger or more fragile foods, consider gently tossing or flipping for even results.
- **Check on foods early.** Check foods on the earlier side of cooking time; you can always slide the basket back in to continue cooking.
- **Follow food safety guidelines for doneness.** Because air fryer temperatures and food sizes can vary, do not rely on recipe timing only when cooking food. Check foods for doneness against current safety guidelines before serving.

TROUBLESHOOTING FAQs

Why is there white smoke coming from my unit?

White smoke can be a sign that there's too much fat in the fryer. Avoid cooking very fatty foods, such as sausages, in the air fryer, and be sure the basket, rack, and heating coil are clean before cooking.

Why has my food cooked unevenly?

Two likely reasons include overcrowding and not shaking. Fill basket loosely with food to let air circulate and shake, toss, or flip foods at least once during cooking for more even results.

Why isn't my food crisp?

Though you can air fry with no added oil, coating foods very lightly with oil (usually just ½ teaspoon per batch for most recipes) helps guarantee crisp results. Preheating the fryer also helps.

CLEANING AND MAINTENANCE

The nonstick coating on the basket and rack makes the Air Fryer easy to clean following the steps below.

1. Unplug and cool completely before cleaning. (For faster cooling, keep hot basket out of the unit.)
2. To remove the cooled rack from basket, use tongs to pinch the center grip bar and pull the rack straight up and out of basket. (Only use your fingers to do this if you are certain rack and basket are completely cooled, otherwise injuries can occur.)
3. Wash the basket and rack with warm soapy water, rinse, and dry well with a towel for best results. Basket and rack are also top-rack dishwasher-safe.
4. Wipe down the outside and the inside of the unit, including the heating coil, with a damp cloth as needed. Do not put the unit in the dishwasher or submerge in water or any other liquid.
5. Do not use abrasive cleansers on basket, rack, exterior, or interior, or you could damage the finishes.

NOTES

NOTES

TERMS AND CONDITIONS

Limited Warranty

Our products are backed by a limited 1-year warranty. To register, follow the instructions on the Chefman® Warranty Registration page in this User Guide.

We offer a limited 1-year warranty from the date of purchase. This warranty is void without proof of purchase within the USA, Canada, or Mexico. Service centers and retail stores do not have the right to alter or change the Terms and Conditions of this warranty.

WHAT THE WARRANTY COVERS

- **Manufacturer Defects**

Chefman® products are warranted against defects in material and workmanship for a period of 1 year from the date of purchase when used in accordance with the Chefman® User Guide.

- **Qualified Replacements**

If your product does not work as it should, we will send you a new one. If the product is no longer available, we will replace it with one that is comparable.

TERMS AND CONDITIONS

Limited Warranty

THIS WARRANTY DOES NOT COVER

- **Misuse** - Damage that occurs from neglectful or improper use of products; damage that occurs as a result of usage with incompatible voltage. See Safety Instructions for information on proper use.
- **Poor Maintenance** - General lack of proper care. See Cleaning and Maintenance for information on proper maintenance.
- **Commercial Use** - Damage that occurs from commercial use.
- **Altered Products** - Damage that occurs from alterations or modifications by any entity other than Chefman®; removal of rating label.
- **Catastrophic Events** - Damage that occurs from fire, floods, or natural disasters.
- **Loss of Interest** - Claims of loss of interest or enjoyment.

CHEFMAN® WARRANTY REGISTRATION

Register your product to add an additional 3 months to your warranty.

What do I Need to Register my Product

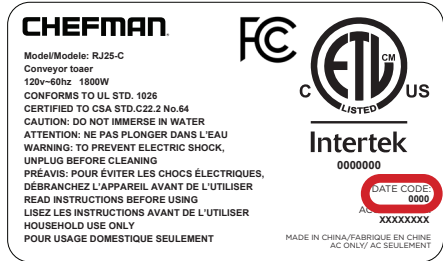

- Contact Information
- Model Number
- Proof of Purchase
(online confirmation, receipt, gift receipt)
- Date code

NOTE: Label depicted here is an exmple.

How Do I Register my Product?

We offer two convenient ways to access the Chefman® registration form:

1. Visit chefman.com/register.
2. Scan the QR code below to access site:

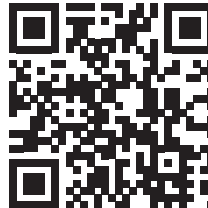

CHEFMAN® WARRANTY REGISTRATION

For product information, visit chefman.com

OTHER LIMITATIONS: ALL WARRANTIES OF ANY KIND WHATSOEVER, EXPRESS, IMPLIED AND STATUTORY, ARE HEREBY DISCLAIMED. ALL IMPLIED WARRANTIES OF MERCHANTABILITY AND FITNESS FOR A PARTICULAR PURPOSE ARE HEREBY DISCLAIMED, PROVIDED THAT IF ANY IMPLIED WARRANTIES OF ANY KIND IS REQUIRED BY ANY JURISDICTION, INCLUDING MERCHANTABILITY AND FITNESS FOR A PARTICULAR PURPOSE, THE DURATION OF SUCH IMPOSED IMPLIED WARRANTY IS LIMITED TO ONE (1) YEAR. THIS WARRANTY DOES NOT COVER, AND CHEFMAN® SHALL NOT BE LIABLE FOR, INCIDENTAL, INDIRECT, SPECIAL OR CONSEQUENTIAL DAMAGES, INCLUDING WITHOUT LIMITATION, DAMAGE TO, OR LOSS OF USE OF THE PRODUCT, OR LOST SALES OR PROFITS OR DELAY OR FAILURE TO PERFORM THIS WARRANTY OBLIGATION. THE REMEDIES PROVIDED HEREIN ARE THE EXCLUSIVE REMEDIES UNDER THIS WARRANTY, WHETHER BASED ON CONTRACT, TORT OR OTHERWISE.

This Warranty gives you specific legal rights, and you may also have other rights that vary from state to state or province to province. Some states or provinces do not allow the exclusions or limitations set forth in this Warranty, so the above limitations or exclusions may not apply to you depending on the jurisdiction of purchase.

Chefman® is a registered trademark of RJ BRANDS, LLC.

CHEFMAN®

@mychefman



www.chefman.com

©CHEFMAN 2020