

CHEFMAN®

TurboFry® Touch
AIR FRYER
with Basket Divider

USER GUIDE

- Safety instructions
- Features
- Operating instructions
- Air frying chart
- Air fryer cooking tips
- Troubleshooting/FAQs
- Cleaning and maintenance
- Notes
- Terms and conditions
- Warranty registration

RJ38-SQSS-8T-D

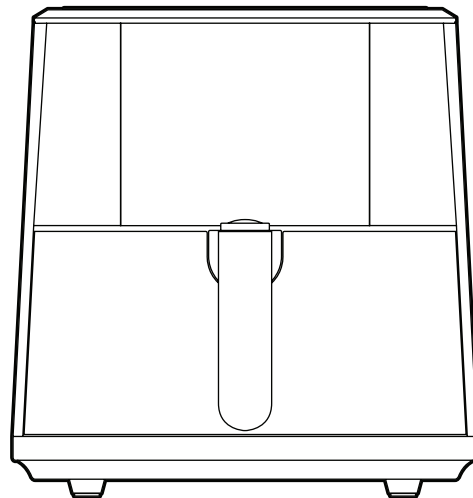

COOKING FORWARD™

Welcome!

Whether this is your first Chefman® appliance or you're already part of our family, we're happy to be cooking with you! With your new TurboFry® Touch Air Fryer with Basket Divider, you can air fry foods to crisp perfection with little to no oil for healthier eating. With its extra-large 8-quart basket capacity, this air fryer lets you make meals for the whole family. Plus, the bonus removable basket divider allows for cooking two different foods at one time without mixing them.

We know you're excited to get cooking, but please take a few minutes to read our directions, safety instructions, and warranty information.

From our kitchen to yours,

The Chefman® Team



READ ALL INSTRUCTIONS BEFORE USE
For your safety and continued enjoyment of this product, always read the instruction manual before using.



CONTENTS

- 4** Safety instructions
- 8** Features
- 11** Operating instructions
- 13** Air frying chart
- 15** Air fryer cooking tips
- 16** Troubleshooting/FAQs
- 17** Cleaning and maintenance
- 18** Notes
- 20** Terms and conditions
- 22** Warranty registration





SAFETY INSTRUCTIONS

IMPORTANT SAFEGUARDS

WARNING: When using electrical appliances, basic safety precautions should always be followed, including:

1. Read all instructions.
2. Do not touch hot surfaces. Use handles or knobs.
3. To protect against electrical shock, do not immerse the cord or plug in water or other liquids.
4. Close supervision is necessary when any appliance is used by or near children.
5. Unplug from the outlet when not in use and before cleaning. Allow to cool before putting on or taking off parts.
6. Do not operate any appliance with a damaged cord or plug, or after the appliance malfunctions or has been damaged in any manner. Contact Chefman® Customer Support.
7. The use of accessory attachments not recommended by the appliance manufacturer may cause injuries.
8. Do not use outdoors.
9. Do not let the cord hang over the edge of a table or counter or touch hot surfaces.
10. Do not place on or near a hot gas or electric burner or in a heated oven.
11. Extreme caution must be used when moving an appliance containing hot oil or other hot liquids.
12. To disconnect, turn any control to OFF, then remove the plug from the wall outlet.
13. Do not use the appliance for other than intended use.
14. Place the unit on a flat, sturdy, heat-resistant surface. Do not place the unit near or on any type of heat source, such as a gas or electric burner, stove, or oven, even if not on. Do not use near an open flame or flammable materials.



SAFETY INSTRUCTIONS

IMPORTANT SAFEGUARDS

15. The unit will emit some heat. Allow sufficient space around the unit when in use, and do not place near other items or appliances.
16. Check that your home power supply corresponds with the intended voltage of the air fryer.
17. Never wrap the cord tightly around the appliance during use or storage; this may cause the wire to fray and break.
18. This product is not a deep fryer. It is NOT meant to be filled with oil. Never fill any parts of the air fryer with oil. If you choose to use oil, toss food with oil in a separate bowl and then transfer food to the removable rack or basket.
19. Do not leave uncooked ingredients in the air fryer for more than a short period of time before cooking; raw meat, poultry, fish, fruits, and vegetables can spoil.
20. Do not move the air fryer while it is full of food.
21. Do not move the unit during use. During initial use, you may notice some smoke and/or a slight odor. This is normal and should quickly dissipate. It should not happen after the appliance has been used a few more times.
22. Do not leave the air fryer unattended during use.
23. Some areas do get HOT during use, and the touch screen may get warm. Do not touch the heating elements. Do not place hands or other body parts near the air vents while the air fryer is in use; burns may result. Take caution when handling the hot air fryer rack and all removable parts.
24. Use protective mitts and/or tongs to remove hot food from the air fryer.

**SAVE THESE INSTRUCTIONS
FOR HOUSEHOLD USE ONLY**



SAFETY INSTRUCTIONS

IMPORTANT SAFEGUARDS

WARNING: This appliance has a polarized plug (one blade is wider than the other). This plug is intended to fit into a polarized outlet only one way. If the plug does not fit fully into the outlet, reverse the plug. If it still does not fit, contact a qualified electrician. Do not attempt to modify the plug in any way or force it into the outlet. This could result in injury or electric shock.

SHORT CORD INSTRUCTIONS

A short power-supply cord is provided to reduce the hazards of entanglement or tripping over a longer cord. Longer detachable power-supply cords or extension cords are available and may be used if care is exercised in their use. If a longer detachable power-supply extension cord is used:

1. The marked electrical rating of the extension cord should be at least as great as the electrical rating of the appliance.
2. The longer cord should be arranged so that it will not drape over the countertop or tabletop where it can be pulled on by children or tripped over.



SAFETY INSTRUCTIONS

IMPORTANT SAFEGUARDS

POWER CORD SAFETY TIPS

1. Never pull or yank on the cord or the appliance.
2. To insert the plug, grasp it firmly and guide it into the outlet.
3. To disconnect the appliance, grasp the plug and remove it from the outlet.
4. Never use the product if the power cord shows signs of abrasion or excessive wear. Contact Chefman® Customer Support for additional guidance and support.
5. Never wrap the cord tightly around the appliance, as this could place undue stress on the cord where it enters the appliance and cause it to fray and break.

DO NOT OPERATE APPLIANCE IF THE POWER CORD SHOWS ANY DAMAGE OR IF APPLIANCE WORKS INTERMITTENTLY OR STOPS WORKING ENTIRELY.

*California Proposition 65:
(Applicable for California Residents only)*



WARNING:
Cancer and Reproductive Harm -
www.P65Warnings.ca.gov.



Do not place the appliance on a stovetop or any other heatable surface, even if stovetop is not on. Doing so is a fire hazard.

FEATURES

1. Control panel
2. Basket rack
3. Basket
4. Basket handle
5. Basket divider

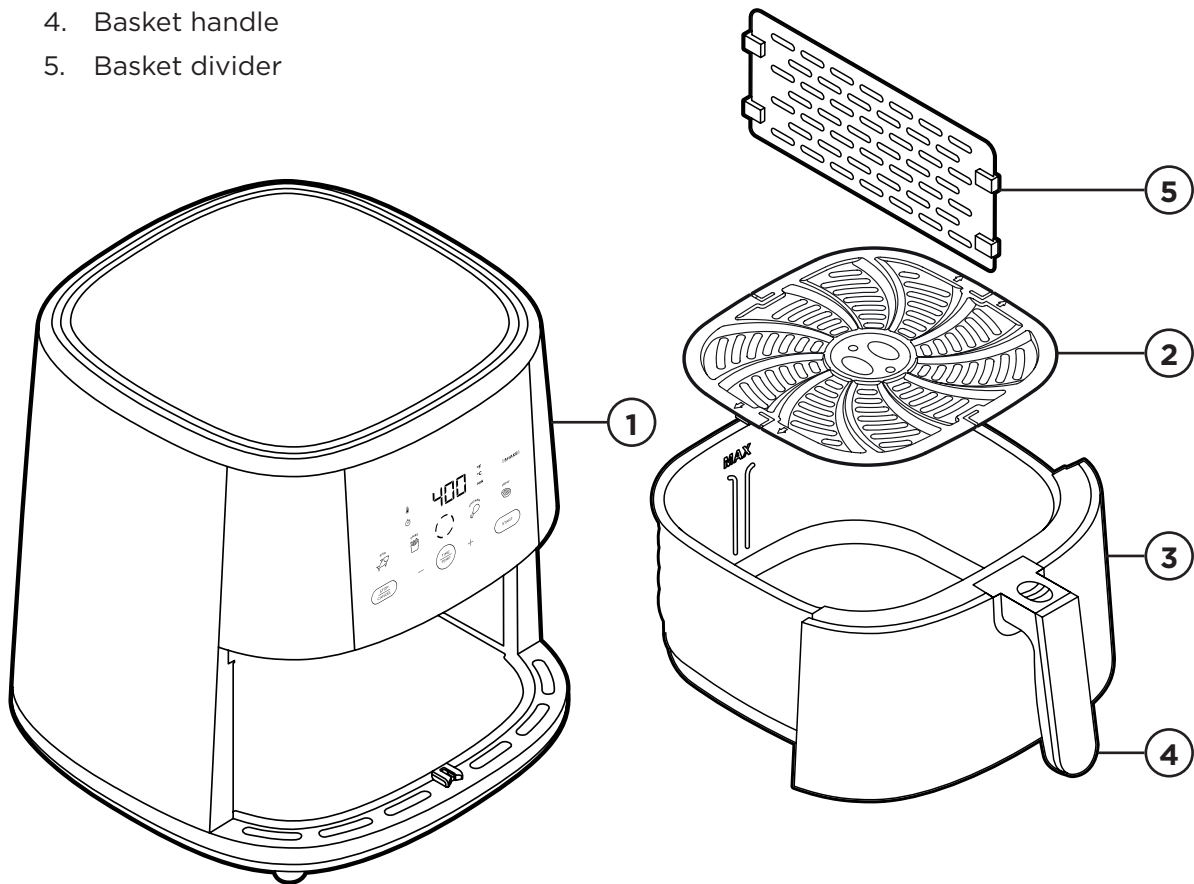

FEATURES

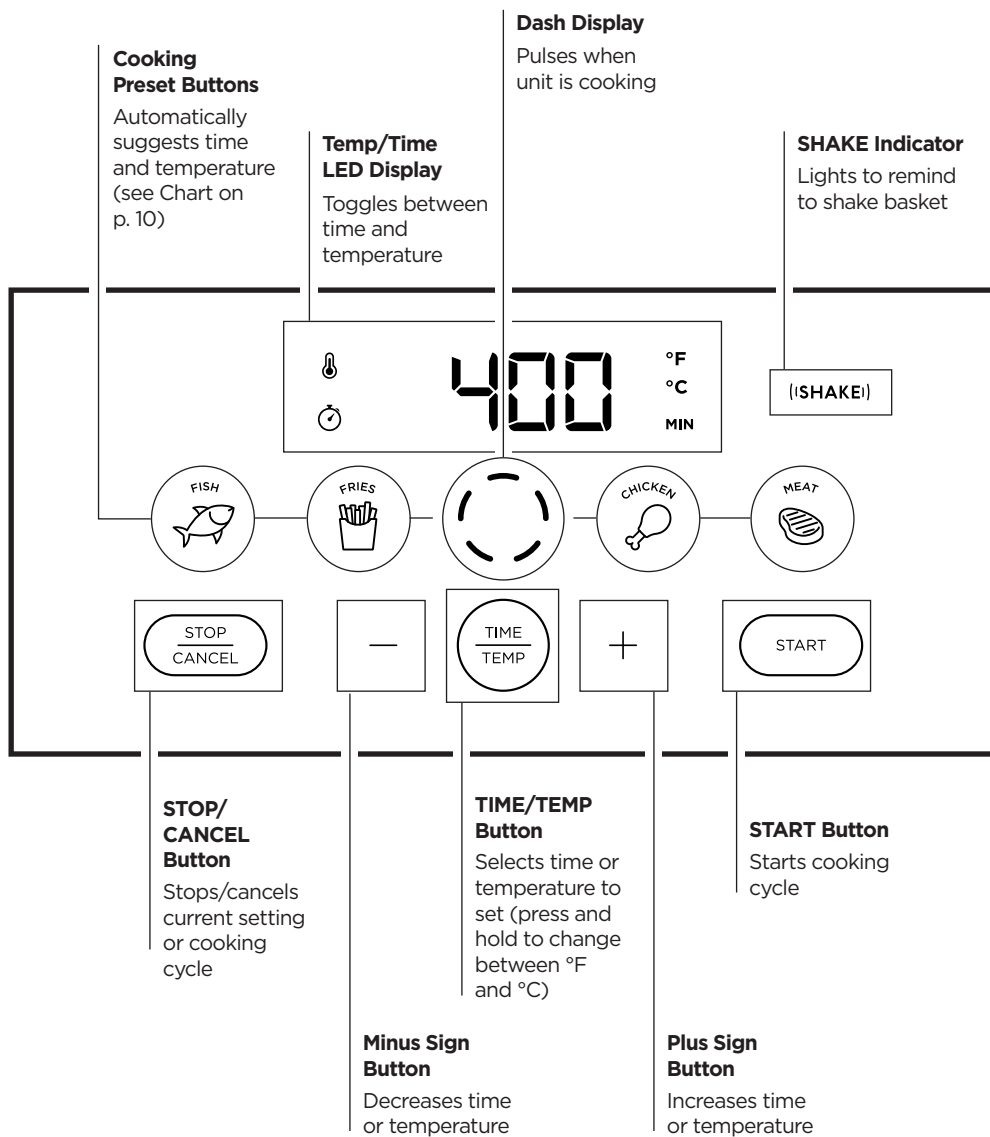

FEATURES

PRESET FUNCTION CHART

These presets represent an average time and temp. To set the air fryer manually, see the chart beginning on p. 13. **NOTE:** If you are using the divider, you may need to add a few extra minutes at the end of the cook time. Be sure to check all foods for doneness before serving.

FUNCTION	Default Time	Default Temp	SHAKE Light Reminder <small>(NOTE: If time is set for more than 30 minutes, SHAKE light will come on every 15 minutes.)</small>
Default	15 min.	400°F	Comes on halfway through default time.
MEAT	18 min.	375°F	Comes on halfway through cook time.
CHICKEN	22 min.	400°F	Comes on halfway through cook time.
FISH	10 min.	375°F	Comes on halfway through cook time. Flip, don't shake, delicate fillets.
FRIES	18 min.	400°F	Comes on halfway through cook time.



OPERATING INSTRUCTIONS

BEFORE FIRST USE

For best results, follow these steps before using your air fryer for the first time.

1. Remove all packaging materials, such as plastic bags and foam inserts. Check to ensure that all parts and accessories are accounted for.
2. Read and remove any stickers on the unit except for the rating label on the bottom, which should remain on the unit.
3. Wipe down the interior and exterior with a damp cloth. Wash the basket, basket rack, and divider with warm, soapy water. Dry thoroughly.

HOW TO COOK IN THE AIR FRYER

The air fryer's high-speed fan cooks your favorite foods quickly. The rack in the basket allows air to circulate around foods for even cooking and crisping, and lets excess fat drip down and away from foods for healthier eating.

CAUTION: Never fill the basket with oil. Unlike deep fryers, air fryers require little to no oil to produce a crisp texture. If you choose to use oil, toss foods with just a little in a separate bowl before cooking in the air fryer.

1. Prepare the food(s) you plan to air fry.
2. Place the air fryer on a hard, flat surface with at least 6 inches of clearance on top and in back for proper air flow, then plug the unit in. The control panel will illuminate, and the default temperature and time will alternate on the display.
3. Lower the rack into the basket with the arrows pointing to the front (the handle side) and back of the basket. Press down on the rack to ensure it is secure and level. There should be a small amount of space between the rack and the bottom of the basket. (For easiest handling of the basket rack, pinch the center grip bar with your thumb and index finger.)

CAUTION: Never use aerosol cooking spray on the air fryer's nonstick parts as it can cause the coating to chip.



OPERATING INSTRUCTIONS

4. If using the divider, slide it into the basket front to back over the rack. You can divide the basket evenly using the grooves in its center as a guide or portion it as you like. The rubber stoppers will keep the divider in place. Press down on the divider, and ensure it's level for a secure fit. To remove the divider, hold the basket down with one hand, then grab the divider with the other. Twist it to tilt to one side as shown on p. 17, then pull it out.
5. Put the food on the rack. To allow for good air circulation, do not fill the basket past the MAX line. Slide the basket into the air fryer.
6. Set the time and temperature as desired, or use cooking preset functions. To set the temperature manually, press the TIME/TEMP button until temperature displays, and then press the plus or minus sign. To set the time, press the TIME/TEMP button until the time displays, and then press the plus or minus sign. If cooking with presets, choose the icon that best represents the food you're cooking and press the icon (see Chart on p. 10 for details).
7. Press START. The fan will come on and circular dashes on the display will animate.
NOTE: During cooking, you can remove the basket to check on, turn, or shake foods. When you return the basket to the unit, the timer and heating will resume where they left off.
8. During cooking, the SHAKE light on the control panel will turn on, and the air fryer will beep as a reminder to shake (or flip) food, as necessary. (See Chart, p. 10, for more details on timing.) The SHAKE light will turn off immediately when the basket is removed and will go off automatically after about 15 seconds if basket is not pulled out. (If your food does not need to be shaken, flipped, or turned, simply ignore the warning.)
9. When the timer is done, the air fryer will turn off automatically. Remove the basket from the air fryer. Check food for doneness, then carefully transfer food to plates or a platter and serve. **NOTE:** On first use, the unit may emit a slight odor, which is normal and will dissipate with use.

AIR FRYING CHART

Use this chart to help you cook some of your favorite foods. Note that the times reflect a 5-minute preheat. If not preheating, please add a few minutes to the cook time. The amounts listed are for the full basket; reduce amounts when using the divider. You may also need to cook foods a little longer when using the divider.

Vegetables	Amount/Prep	Toss with oil?	Time (min)	Temp (°F)	Shake/Flip
Asparagus	1 bunch, tough ends trimmed	Yes	6-9	400	Flip once
Broccoli	1 head, cut into florets	Yes	7-9	375	Shake once
Brussels sprouts	10 oz (about 20), halved	Yes	15	380	Shake once
Carrots	1 lb, peeled, cut into 1" pieces	Yes	11-13	400	Shake once
Cauliflower	½ head, cut into florets	Yes	15-17	400	Shake once
Corn on the cob	4 whole ears, husked	Brush w/a little oil or butter	15	400	Flip once
Green beans	1 lb, trimmed	Yes	7-9	400	Shake once
Potatoes (red/yellow)	1 lb, cut into 1-inch chunks	Yes	15	400	Shake once
Potatoes (baking)	3 whole potatoes	Yes	30-38	400	No
Sweet potatoes	1 lb, peeled, cut into 1" chunks	Yes	15	400	Shake once
Zucchini	1 lb, cut into 1" chunks	Yes	15-16	400	Shake once
Seafood	Amount/Prep	Toss with oil?	Time (min)	Temp (°F)	Shake/Flip
Crab cakes	4 cakes (about 4 oz each)	Brush lightly	12-15	375	No
Salmon	2 fillets (about 6 oz each)	Brush skin lightly	10-12 (medium)	400	Flip once
Shrimp	1 lb, peeled	Yes	5-6	400	Shake once
Thin fish fillet (e.g., flounder)	2 fillets (about 4 oz each)	Brush lightly	6-8	350	Gently flip once

AIR FRYING CHART

Meat	Amount/Prep	Toss with oil?	Time (min)	Temp (°F)	Shake/Flip
Bacon	4 slices	No	10	400	No, but check bacon isn't touching
Chicken breast (boneless, skinless)	3 halves (6-8 oz each), seasoned as desired	Brush lightly	18-22	375	Flip once
Chicken wings (flats and drumettes)	15 pieces, seasoned as desired	Yes	30-32	400	Shake once
Hamburgers/ Cheeseburgers*	4 patties (4 oz each) (80% lean)	No	9 (medium)	380	Flip once
Pork chops (bone-in)	2 chops (1" thick), seasoned as desired	No	15-18	400	Flip once
Steak	2 steaks (¾" thick), seasoned as desired	No	11 (medium)	400	Flip once
Frozen foods	Amount/Prep	Toss with oil?	Time (min)	Temp (°F)	Shake/Flip
Apple turnovers	4	No	16-18	350	No
Chicken tenders	7 pieces	No	11-13	375	Flip once
Chicken nuggets	20 pieces	No	10	400	Gently flip once
Fish sticks	18 pieces	No	8-9	400	Gently flip once
French fries (thin)	1½ lb	Yes	17-19	400	Shake once
French fries (thick)	1½ lb	Yes	20-22	400	Shake once
Mozzarella sticks	16 pieces	No	7	380	Flip once
Tater tots	1 lb	No	15	400	Shake once

NOTE: The times and temperatures offered in these charts are suggestions and may vary. Please follow current food safety guidelines when determining doneness.

*For cheeseburgers, top with cheese after time is up. Let melt in still-hot fryer.



AIR FRYER COOKING TIPS

Preheat the air fryer for 5 minutes before cooking. While not necessary, preheating the unit will cook foods faster and promote crisp results. If the unit is cold, add a few minutes to your expected cooking time. **CAUTION:** Be careful when adding food after preheating as the inside of the fryer will be hot.

For a crisp exterior, oil foods lightly. Some foods, especially if fresh, benefit from being tossed with a little oil in a separate bowl before frying.

Avoid wet batters. Loose batters, such as those used for deep frying, do not work in air fryers, as the batter simply slides off. Adapt such recipes to give foods a thicker coating, preferably including breadcrumbs to help the coating adhere.

Use medium-high to high heat for most cooking. Most foods will air fry best between 325°F and 400°F. For gentler cooking and reheating, use a lower temperature to avoid overcooking.

Don't overcrowd the basket. Too much food, especially if tightly packed, can inhibit browning and crisping. A better bet: Fry food in batches.

Shake the basket during cooking for even cooking. A good shake is especially beneficial for smaller items like french fries, onion rings, and chicken wings. For larger or more fragile foods, consider gently tossing or flipping for even results.

Check on foods early. Check foods on the earlier side of cooking time; you can always slide the basket back in to continue cooking. If using the divider, you may need to remove quicker cooking foods before longer cooking foods are done.

Follow food safety guidelines for doneness. Because air fryer temperatures and food sizes can vary, do not rely solely on recipe timing when cooking food. Check foods for doneness against current safety guidelines before serving.



TROUBLESHOOTING/FAQS

Why is there white smoke coming from my unit?

White smoke can be a sign that there's too much fat in the fryer. Avoid cooking very fatty foods, such as sausages, in the air fryer, and be sure the basket, the rack, and the interior of the air fryer are clean before cooking.

Why has my food cooked unevenly?

Two culprits are likely: overcrowding and not shaking. Fill the air fryer basket loosely with food to let air circulate, and shake, toss, or flip foods at least once during cooking for more even results.

Why isn't my food crisp?

Though you can air fry with no added oil, coating foods very lightly with oil (usually just $\frac{1}{2}$ teaspoon per batch for most recipes) helps guarantee crisp results. Preheating the fryer also helps.

Why is the unit displaying an error code?

If your air fryer displays E1 or E2 on its control panel, it means there is a loose wire contact or a short circuit, and the unit will not function. Should this occur, please contact Chefman® Customer Support for a replacement.



CLEANING AND MAINTENANCE

The nonstick coating on the basket, rack, and divider makes the air fryer easy to clean following the steps below.

1. Unplug the unit and let cool completely before cleaning. (For faster cooling, take the hot basket out of the unit.)
2. Remove the cooled divider from the basket, if necessary. To remove the divider, hold the basket with one hand, then grab the divider with the other. Twist the divider to tilt it to one side as shown below, then pull it out. To remove the rack from the basket, pinch the center grip bar at the bottom of the basket, and pull the rack straight up and out of the basket. **WARNING:** Do not lift the rack out of the basket when hot, or injury can occur.

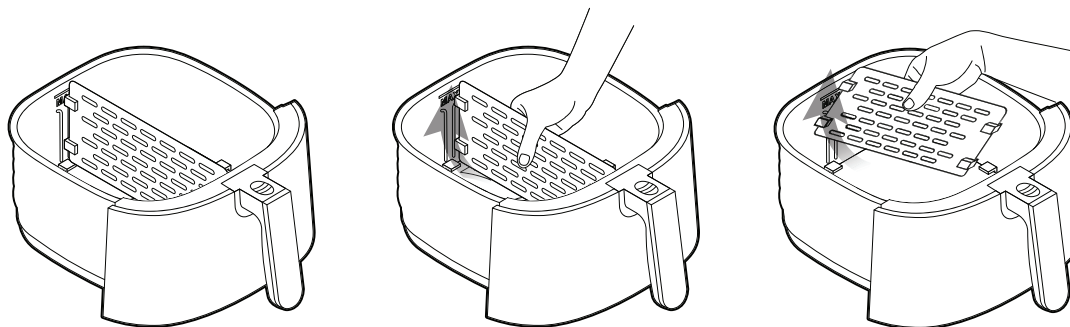

3. Wash the basket, rack, and divider with warm, soapy water, rinse, and dry well with a towel for best results. The basket, rack, and divider are also top-rack dishwasher safe.
4. Wipe down the outside and the inside of the unit with a damp cloth as needed. Store the unit in a cool, dry place.
5. Do not put the unit in the dishwasher or submerge in water or any other liquid. Do not use abrasive cleaners, or you could damage the finishes.



NOTES



TERMS AND CONDITIONS

Limited Warranty

RJ Brands, LLC d/b/a Chefman® offers a limited 1-year Warranty (the “Warranty”) available on sales through authorized distributors and retailers only. Please note that this Warranty becomes valid from the date of initial retail purchase and that the Warranty is non-transferable and applies only to the original purchaser.

This Warranty is void without proof of purchase within the United States and Canada. Please be aware that this Warranty supersedes all other warranties and constitutes the entire agreement between the consumer and Chefman®. Any changes to the Terms and Conditions of this Warranty must be in writing, signed by a representative of Chefman®. No other party has the right or ability to alter or change the Terms and Conditions of this Warranty.

We may ask you to please submit, via email, photos and/or video of the issue you are experiencing. This is to help us better assess the matter and possibly offer a quick fix. Photos and/or video may also be required to determine Warranty eligibility.

We encourage you to register your product. Registering can make the Warranty process easier and can keep you informed of any updates or recalls on your product. To register, follow the directions on the Chefman® Warranty Registration page in the Chefman® User Guide. Please retain your proof of purchase even after registering. In the event that you do not have proof of your purchase date, we may declare your Warranty void or we may, at our sole discretion, apply the date of manufacture as the purchase date for purposes of this Warranty.





TERMS AND CONDITIONS

Limited Warranty

WHAT THE WARRANTY COVERS

- **Manufacturer Defects** – Chefman® products are warranted against defects in material and workmanship, under normal household use, for a period of 1 year from the date of purchase when used in accordance with the directions listed in the Chefman® User Guide. If your product does not work as it should, please contact Customer Support at support@chefman.com so that we may assist you.

THIS WARRANTY DOES NOT COVER

- **Misuse** – Damage that occurs from neglectful or improper use of products, including, but not limited to, damage that occurs as a result of usage with incompatible voltage, regardless of whether the product was used with a converter or adapter. See Safety Instructions in the Chefman® User Guide for information on proper use of product;
- **Poor Maintenance** – General lack of proper care. We encourage you to take care of your Chefman® products so that you may continue to enjoy them. Please see Cleaning and Maintenance directions in the Chefman® User Guide for information on proper maintenance;
- **Commercial Use** – Damage that occurs from commercial use;
- **Normal Wear and Tear** – Damage or degradation expected to occur due to normal use over time;
- **Altered Products** – Damage that occurs from alterations or modifications by any entity other than Chefman® such as the removal of the rating label affixed to the product;
- **Catastrophic Events** – Damage that occurs from fire, floods, or natural disasters;
- **Loss of Interest** – Claims of loss of interest or enjoyment.

CHEFMAN® WARRANTY REGISTRATION

What do I need to register my product?

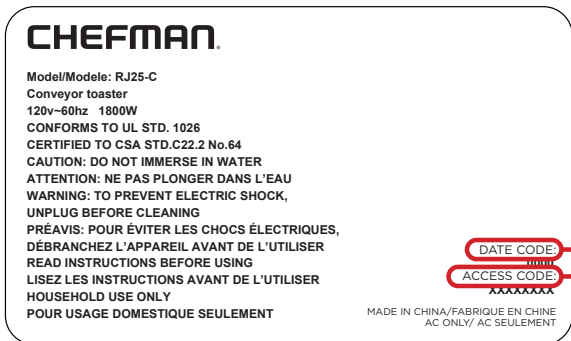

- Contact Information
- Model Number
- Proof of Purchase (online confirmation, receipt, gift receipt)
- Date Code
- Access Code

NOTE: Label depicted here is an example.

How do I register my product?

All you need to do is fill out a simple Chefman® registration form. You can easily access the form in one of the two ways listed below:

1. Visit Chefman.com/register.
2. Scan the QR code to access site:







CHEFMAN® WARRANTY REGISTRATION

For product information, visit Chefman.com

EXCEPT WHERE SUCH LIABILITY IS REQUIRED BY LAW, THIS WARRANTY DOES NOT COVER, AND CHEFMAN® SHALL NOT BE LIABLE FOR, INCIDENTAL, INDIRECT, SPECIAL, OR CONSEQUENTIAL DAMAGES, INCLUDING WITHOUT LIMITATION, DAMAGE TO, OR LOSS OF USE OF THE PRODUCT, OR LOST SALES OR PROFITS OR DELAY OR FAILURE TO PERFORM THIS WARRANTY OBLIGATION. THE REMEDIES PROVIDED HEREIN ARE THE EXCLUSIVE REMEDIES UNDER THIS WARRANTY, WHETHER BASED ON CONTRACT, TORT OR OTHERWISE.



Chefman® is a registered trademark of RJ Brands, LLC.
TurboFry® is a registered trademark of RJ Brands, LLC.
Cooking Forward™ is a trademark of RJ Brands, LLC.



CHEFMAN®



CHEFMAN.COM | @MYCHEFMAN

©CHEFMAN 2023