

**CHEFMAN**<sup>®</sup>

**RJ23-SG**

---

**ELECTRIC**  
**INDOOR GRILL**



**CUSTOMER SERVICE:** 888.315.6553 | [customerservice@chefman.com](mailto:customerservice@chefman.com)

## **Congratulations on your purchase!**

Every Chefman product is manufactured to the highest standards of performance and safety. We are confident that you will be so satisfied with your purchase that Chefman will be your go-to company for appliances in the future.

Customer satisfaction is a key element of our company's philosophy. The Chefman brand exists to fill a void on retail shelves and in consumer kitchens for a truly value-focused kitchen appliance. By questioning and adding value and innovation at every touchpoint in the manufacturer to end user journey, Chefman provides home chefs with the tools they need to achieve picture-perfect results with maximum efficiency. In addition to Chefman products being dependable and affordable, they're built with intuitive features to enhance the kitchen experience so home cooks can become home chefs.

Should a problem arise, each product is backed by a comprehensive manufacturer's one-year warranty, as well as, outstanding after-sales service support through our dedicated customer service team. In the unlikely event that your product does not operate as described in this user guide, please feel free to call or email customer service for assistance. We understand that sometimes products can malfunction, so if you feel that your appliance is not operating as it should, warranty claims can be made within one year from the date of purchase when accompanied by a dated receipt.

This guarantee is in addition to your statutory rights; your statutory rights are not affected. This limited warranty does not apply in cases of damage caused by accident, improper use, abuse or force majeure.

This warranty gives you specific legal rights. Rights may vary depending on your state or province of residence. Some locations do not allow limitations on implied warranties or special incidental, or consequential damages, so the limitations may not apply to you. This limited warranty will be invalidated if the appliance is tampered with in any way whatsoever.

Call Chefman Customer Service at (888) 315-6553 or email [customerservice@chefman.com](mailto:customerservice@chefman.com) for help with questions or to receive technical assistance. We're available Monday through Friday 9 a.m. to 5 p.m. EST.



### **READ ALL INSTRUCTIONS BEFORE USE**

For your safety and continued enjoyment of this product, always read the instruction manual before using.

# INTRODUCTION

We're so excited that you chose the Chefman Electric Indoor Grill to be the newest addition to your kitchen. Satisfying cravings is no longer dependent on the season. Now you can look forward to grilling all your favorite foods indoors, year-round! Think: inviting guests to an indoor barbecue in the middle of winter. With this grill, you can achieve the same grill marks and enticing flavor and aroma that comes from traditional grilling without ever igniting a flame. Best of all, this grill produces virtually no smoke and has the easiest clean-up thanks to a dishwasher-safe drip tray and grate.

Read this entire User Guide to get to know the Chefman Electric Indoor Grill before getting started.



# FUN FACTS

- The number one grilling holiday in the U.S. is the 4th of July.
- The main styles of barbeque can be divided into Memphis, Kansas City, Texas and Carolina-style.
- Hamburgers are the most grilled food in the U.S.

# CONTENTS

- 1** Safety Instructions
- 4** Features
- 5** Operating Instructions
- 7** Cleaning and Maintenance/ Cooking Tips
- 8** Notes
- 9** Terms and Conditions
- 10** Warranty Card

# SAFETY INSTRUCTIONS

## IMPORTANT SAFEGUARDS

### FOR HOUSEHOLD USE ONLY.

**WARNING:** When using electrical appliances, especially when children are present, basic safety precautions should always be followed to reduce the risk of fire, electric shock and/or injury to persons, including the following:

1. Read all instructions.
2. Do NOT touch hot surfaces. Use cool-touch handles. Always use oven mitts when handling hot material.
3. Do NOT stare directly at the heating element light. Extended visual exposure can cause eye damage. To avoid serious or fatal injury, NEVER touch the heating elements or any other hot surfaces when the product is in use.
4. To protect against electric shock, do NOT immerse power cord, plugs or the grill itself in water or other liquid.
5. Close supervision is necessary when this grill is used near children.
6. Never leave the grill unattended when operating.
7. Unplug grill from outlet when not in use and before cleaning. Allow to cool before putting on or taking off parts, and before cleaning the grill.
8. Do NOT operate the grill with a damaged power cord or plug, or after the grill malfunctions or has been damaged in any manner. Contact Chefman Customer Service at 1-(888)-315-6553 or [customerservice@chefman.com](mailto:customerservice@chefman.com).
9. Do NOT let the power cord hang over the edge of a table or countertop or touch hot surfaces.
10. The use of accessory attachments not recommended by Chefman may cause injuries.
11. This grill is intended for indoor use only. Do NOT use outdoors.
12. Do NOT expose to high temperatures or place on or near a hot gas or electric burner, or in a heated oven.
13. Extreme caution must be used when removing or disposing of hot grease.
14. Do NOT place cooking utensils on the grill when in use.
15. Do NOT place paper, cardboard or plastic on the grill.

# SAFETY INSTRUCTIONS

## IMPORTANT SAFEGUARDS

16. Do NOT place any food or objects on the drip tray when the grill is switched on.
17. Use caution when grilling fatty meats like sausage, as spattering of fat can occur.
18. Always place food on the grill plate. Never place food directly on the heating element inside the grill.
19. Do NOT cover any part of the grill with metal foil as this will cause the grill to overheat.
20. Make sure the grill, drip tray and the outside of the base are clean and dry before plugging its power cord into an outlet.
21. If using an extension cord, always attach the extension cord to the grill first, then plug the cord in the wall outlet. To disconnect, turn the grill off, and remove the plug from the wall outlet.
22. Do NOT use the grill for anything other than its intended use.
23. Do NOT use charcoal or wood with this grill.
24. Do NOT pour liquids such as beer or water onto the grill, as this could cause a fire.
25. Always clean the grill after each use. Do NOT clean with metal scouring pads as pieces can break off and touch electrical parts, creating a risk of electric shock.
26. Never use the grill without the grill plate or drip tray in place. Always put the grill plate and drip tray on the grill before you plug it in and switch on. Do NOT use the grill if the drip tray is warped in any way.
27. Some countertop and table surfaces, such as Corian-style countertops, wood and/or laminates, are NOT designed to withstand prolonged heat generated from this grill. Place hot pad or trivet under the grill to prevent possible damage to countertops.
28. Do NOT attempt to cut food while it is grilling.

**SAVE THESE INSTRUCTIONS.**

# SAFETY PRECAUTIONS

## IMPORTANT SAFEGUARDS

**WARNING:** This appliance has a polarized plug (one blade is wider than the other). This plug is intended to fit into a polarized outlet only one way. If the plug does not fit fully into the outlet, reverse the plug. If it still does not fit, contact a qualified electrician. Do NOT attempt to modify the plug in any way or force it into the outlet. This could result in injury or electric shock.

### SHORT CORD INSTRUCTIONS

A short power supply cord is provided to reduce the hazards of entanglement or tripping over a longer cord. Longer detachable power-supply cords or extension cords are available and may be used if care is exercised in their use. If a longer detachable power-supply extension cord is used:

1. The marked electrical rating of the extension cord should be at least as great as the electrical rating of the appliance.
2. The cord should be arranged so that it will not drape over the countertop or tabletop where it can be pulled on by children or tripped over unintentionally.

### POWER CORD SAFETY TIPS

1. Never pull or yank on cord or the appliance.
2. To insert plug, grasp it firmly and guide it into outlet.
3. To disconnect appliance, grasp plug and remove it from outlet.
4. Before each use, inspect the power cord for cuts and/or abrasion marks. If any are found, this indicates that the appliance should be serviced, and the power cord replaced. Please return it to an authorized service representative or contact Chefman Customer Service for assistance.
5. Never wrap the cord tightly around the appliance, as this could place undue stress on the cord where it enters the appliance and cause it to fray and break.

**DO NOT OPERATE APPLIANCE IF THE POWER CORD SHOWS ANY DAMAGE OR IF APPLIANCE WORKS INTERMITTENTLY OR STOPS WORKING ENTIRELY.**

California Proposition 65:  
(Applicable for California Residents only)



**WARNING:**  
Cancer and Reproductive Harm -  
[www.P65Warnings.ca.gov](http://www.P65Warnings.ca.gov)



**WARNING:**  
**DO NOT STARE DIRECTLY AT THE HEATING ELEMENT LIGHT**  
Extended visual exposure can cause eye damage. To avoid serious or fatal injury, NEVER touch the heating elements or any other HOT surfaces when the product is in use.



**Do not place the appliance on a stovetop or any other heated surface.**



# FEATURES

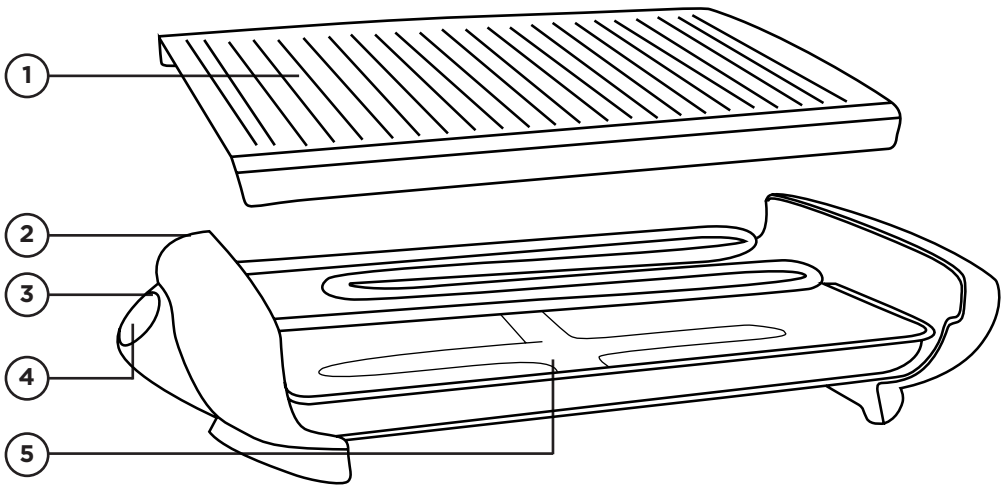

1. Removable Grill Plate with Non-Stick Coating
2. Cool Touch Handles
3. Indicator ON/OFF Light
4. Temperature Control Dial
5. Water Fill/Drip Tray

# OPERATING INSTRUCTIONS

## BEFORE FIRST USE

1. Remove any packing materials, plastic bags or stickers before first use. Be sure to remove all parts from packaging before disposing of anything. NOTE: Remove plastic covering on drip tray before operating grill. NEVER operate grill before removing all packaging and stickers.
  2. Wipe the grill clean with a soft, damp cloth.
  3. Wash the grill plate in warm, soapy water. Dry thoroughly. NOTE: Do NOT use abrasive cleaners or scouring pads on the non-stick surface as this can result in damaged coating.
  4. Before turning the grill on, remove the drip tray and pour in water to a level anywhere between the minimum and maximum lines.
  5. When used for the first time, it is normal for the heating element to have minimal smoke and/or a slight odor, but that should stop within a few moments.
  6. Place the drip tray back into the grill before plugging in or turning on.
- NOTE: To use grill, fill the drip tray with water anywhere between the minimum and maximum lines.

## PREHEATING

- Preheat the grill for approximately 5 - 10 minutes before use.
- Turn the control dial to ON. NOTE: As soon as the control dial is turned on, the power indicator light will illuminate.

## GRILLING

- Allow the grill to preheat for 5-10 minutes and then turn the dial to the actual desired temperature using the marking level you prefer. The temperature range is from low (for keeping food warm) to high (for searing steaks). As you turn the dial clockwise the temperature will increase (high). As you turn the dial counterclockwise towards OFF the temperature will decrease (low).
- NOTE: Refer to the Cooking in the Zone sheet to learn how to arrange foods on the grill according to your desired level of doneness.
- **Warning:** Charcoal or similar combustible material must NOT be used with this grill.
- Any liquids, oils or fats that drip from the food will land into the water filled drip tray. The fats and oils will solidify in the water, thus preventing any additional smoke or odors.

# OPERATING INSTRUCTIONS

- If the drip tray requires additional water during cooking, this can be added by partially removing the drip tray using the built-in handle. Do NOT pour water directly over the grill plate. NOTE: Use caution when using the drip tray handle during cooking as it may be hot.
- Always turn the Temperature Control Dial to the OFF position to turn the grill off.

## WARNINGS

- Do NOT use this grill without water in tray.
- Do NOT pour water over the heating element.
- Do NOT touch the grill plate while cooking as it is extremely hot. Avoid touching the drip tray if possible while cooking as it is very hot.

# COOKING TIPS

- For best results, pre-heat the grill for at least 5 minutes.
- When using wooden or bamboo skewers to make kebabs, soak the skewers in warm water for at least 30 minutes prior to grilling.
- Cut slits into food before marinating for better absorption of flavor.
- Marinate meat a minimum of 30 minutes to a maximum of 24 hours before grilling for more tender, flavorful results.
- Marinate seafood for 30 minutes to 1 hour before grilling.
- Avoid grilling foods that are crusted with breadcrumbs.
- Do NOT use charcoal or wood chips in the grill.
- Do NOT use non-stick cooking spray on the grill plate as it could damage the non-stick coating.
- A sign that meat is ready to be flipped is when it raises away slightly from the grill plate and starts to crackle or sizzle. If you try to flip and realize the meat is sticking to the grill plate, wait another 30 seconds to 1 minute before trying again.
- Use paprika and chipotle spices to achieve a smoky flavor.

# CLEANING AND MAINTENANCE

- Unplug the grill from the outlet and allow to cool thoroughly before cleaning.
- Wipe the grill with a damp cloth and dry thoroughly.
- To avoid scratching the non-stick surface do NOT use any harsh or abrasive cleaning agents.
- Wash the grill plate in warm, soapy water. Dry thoroughly.
- Do NOT immerse the grill body in water or any other liquids.



# TERMS & CONDITIONS

## Limited Warranty

CHEFMAN® warrants, subject to the conditions stated below, that from the date of purchase, this product will be free from mechanical defects for a period of ONE (1) year. CHEFMAN®, at its option, will repair or replace this product found to be defective during the warranty period. Should this product become defective by reason of improper workmanship or material defect during the specified warranty period, CHEFMAN® will repair or replace the same effecting all necessary parts replacements for a period of one year from the date of purchase. If product is no longer available we will replace it with a product of equal value. Transportation charges on parts, or products in whole, submitted for repair or replacement, under this warranty, must be borne by the purchaser. This warranty is void if the product is used for other than single-family household use or subjected to any voltage and waveform other than as specified on the rating label (e.g., 120V - 60 Hz).

This warranty is available to consumers only. You are a consumer if you own a CHEFMAN® product that was purchased at retail for personal, family or household use. Except as otherwise required under applicable law, this warranty is not available to retailers or other commercial purchasers or owners.

**CONDITIONS:** This warranty is valid for the original USA and Canada retail purchaser from the date of initial retail purchase and is not transferable. Keep the original sales receipt. Proof of purchase is required to obtain warranty service or replacement. Dealers, service centers, or retail stores do not have the right to alter, modify or in any way, change the terms and conditions of this warranty. Warranty registration is not necessary to obtain warranty on CHEFMAN® Products. Save your proof of purchase receipt.

**ABOUT YOUR PRODUCT WARRANTY:** Most warranty repairs are handled routinely, but sometimes requests for warranty service may not be appropriate. For example, warranty service would NOT apply if the product damage occurred because of misuse, lack of routine maintenance, shipping, handling, 3rd party warehousing or improper installation. Similarly, the warranty is void if the manufacturing date or the serial number on the product has been removed or the equipment has been altered or modified. During the warranty period, the authorized service dealer, at its option, will repair or replace any part that, upon examination, is found to be defective under normal use and service.

**NORMAL WEAR:** This warranty does not cover normal wear of parts or damage resulting from any of the following: negligent use or misuse of the product; improper voltage or current; use contrary to the operation instructions; deviation from instructions regarding storage and transportation; repair or alteration by anyone other than CHEFMAN® or an authorized service center. Further, the warranty does not cover Acts of God, such as fire, flood, hurricanes and tornadoes. CHEFMAN® shall not be liable for any incidental or consequential damages caused by the breach of any express or implied warranty. Except to the extent prohibited by applicable law, any implied warranty of merchantability or fitness for a particular purpose is limited in duration to the duration of the above warranty. Some states, provinces or jurisdictions do not allow the exclusion or limitation of incidental or consequential damages or limitations on how long an implied warranty lasts, so the above limitations or exclusion may not apply to you. This warranty gives you specific legal rights, and you may also have other rights that vary from state to state or province to province.

**HOW TO OBTAIN WARRANTY SERVICE:** If your CHEFMAN® product should prove to be defective within the warranty period, we will repair it, or if we think necessary, replace it. To obtain warranty service, simply email [customerservice@chefman.com](mailto:customerservice@chefman.com) or call our toll-free number 1-888-315-6553 for additional information from our Customer Service Representatives, or send the defective product to Customer Service at Chefman, 200 Performance Drive, Mahwah, NJ 07495.

This warranty is effective for the time periods listed above and subject to the conditions provided for within this policy.

### CALIFORNIA RESIDENTS ONLY:

California law provides that for In-Warranty Service, California residents have the option of returning a nonconforming product (A) to the store where it was purchased or (B) to another retail store which sells CHEFMAN® products of the same type. The retail store shall then, at its discretion, either repair the product, refer the consumer to an independent repair facility, replace the product, or refund the purchase price less the amount directly attributable to the consumer's prior usage of the product. If the above two options do not result in the appropriate relief to the consumer, the consumer may then take the product to an independent repair facility if service or repair can be economically accomplished. CHEFMAN® and not the consumer will be responsible for the reasonable cost of such service, repair, replacement, or refund for nonconforming products under warranty.

CHEFMAN® is a registered trademark of RJ BRANDS, LLC.

# WARRANTY

**ELECTRIC  
INDOOR GRILL**

**CHEFMAN®**



All data fields are required in order for us to process your request:

Model Number: \_\_\_\_\_

Full Name: \_\_\_\_\_

Address: \_\_\_\_\_

\_\_\_\_\_

\_\_\_\_\_

Phone: \_\_\_\_\_ Email: (if applicable) \_\_\_\_\_

Date of Purchase\*: \_\_\_\_\_

\*We recommend you keep the receipt with this warranty card

Retail Store of Purchase: \_\_\_\_\_

**Description of Malfunction:**

\_\_\_\_\_  
\_\_\_\_\_  
\_\_\_\_\_  
\_\_\_\_\_  
\_\_\_\_\_

Return your completed warranty card to:

**RJ Brands  
200 Performance Drive  
Suite 207  
Mahwah, NJ  
07495**

**ELECTRIC  
INDOOR GRILL**

**MODEL:  
RJ23-SG**

**888.315.6553**

**customerservice@chefman.com**

**Phone lines available Monday to Friday, 9am-5pm EST  
1-YEAR LIMITED WARRANTY**

**RJ23-SG**

**10**

# CHEFMAN®



CHEFMAN.COM | @MYCHEFMAN