

CHEFMAN[®]

Programmable
COFFEE
MAKER

USER GUIDE

RJ14-12-RO

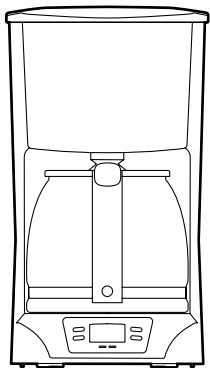

COOKING FORWARD

Welcome!

Whether this is your first Chefman® appliance purchase or you're already part of our family, we're happy to be brewing with you! With your new programmable coffee maker, you can have a pot of delicious, piping hot coffee ready and waiting for you when you wake up. And thanks to its brushed stainless-steel accents, your coffee maker looks good as it brews, too.

We know you're excited to get brewing, but please take a few minutes to read our directions, safety instructions, and warranty information.

If you have any questions, please reach out; we have a dedicated helpline staffed with real people who can quickly answer all your questions.



READ ALL INSTRUCTIONS BEFORE USE

For your safety and continued enjoyment of this product, always read the instruction manual before using.

CONTENTS

- 1 Safety Instructions
- 5 Features
- 6 Operating Instructions
- 12 Cleaning and Maintenance
- 14 Coffee Making Tips
- 15 Notes
- 17 Terms and Conditions
- 19 Warranty Registration

SAFETY INSTRUCTIONS

IMPORTANT SAFEGUARDS

When using electrical appliances, basic safety precautions should always be followed, including the following:

1. Read all Instructions.
2. Do not touch hot surfaces. Use handles or knobs.
3. To protect against fire, electric shock and injury to persons, do not immerse cord or plugs in water or other liquid.
4. Close supervision is necessary when any appliance is used by or near children.
5. Unplug from outlet when not in use and before cleaning. Allow to cool before putting on or taking off parts, and before cleaning the appliance.
6. Do not operate any appliance with a damaged cord or plug or after the appliance malfunctions, or has been damaged in any manner. Contact Chefman® Customer Support at 1-888-315-6553 or support@chefman.com.
7. The use of accessory attachments not recommended by Chefman® may result in fire, electric shock or injury to persons.

SAFETY INSTRUCTIONS

IMPORTANT SAFEGUARDS

8. Do not use outdoors.
9. Do not let cord hang over edge of table or counter, or touch hot surfaces.
10. Do not place on or near a hot gas or electric burner, or in a heated oven.
11. Plug cord into the wall outlet first. To disconnect, turn control to "off" then remove plug from wall outlet.
12. Do not use appliance for other than intended use.
13. **WARNING:** Do not open lid when coffee is brewing. Hot steam may be released, which can result in scalding and other injuries.

SAVE THESE INSTRUCTIONS

SAFETY INSTRUCTIONS

IMPORTANT SAFEGUARDS

WARNING: This appliance has a polarized plug (one blade is wider than the other). To reduce the risk of electric shock, this plug is intended to fit into a polarized outlet only one way. If the plug does not fit fully into the outlet, reverse the plug. If it still does not fit, contact a qualified electrician. Do not attempt to modify the plug in any way.

SHORT CORD INSTRUCTIONS

A short power supply cord is provided to reduce the hazards resulting from entanglement or tripping over a longer cord. Longer detachable power-supply cords or extension cords are available and may be used if care is exercised in their use. If a longer detachable power-supply extension cord is used:

1. The marked electrical rating of the cord set or extension cord should be at least as great as the electrical rating of the appliance, and:
2. The cord should be arranged so that it will not drape over the countertop or tabletop where it can be pulled on by children or tripped over.

SAFETY INSTRUCTIONS

IMPORTANT SAFEGUARDS

POWER CORD SAFETY TIPS

1. Never pull or yank on cord or the appliance.
2. To insert plug, grasp it firmly and guide it into outlet.
3. To disconnect appliance, grasp plug and remove it from outlet.
4. Before each use, inspect the power cord for cuts and/or abrasion marks. If any are found, this indicates that the appliance should be serviced and the power cord replaced. Please contact Chefman® Customer Service.
5. Never wrap the cord tightly around the appliance, as this could place undue stress on the cord where it enters the appliance and cause it to fray and break.
6. This appliance has a polarized plug (one blade is wider than the other). To reduce the risk of electric shock, this plug is intended to fit into a polarized outlet only one way. If the plug does not fit fully into the outlet, reverse the plug. If it still does not fit, contact a qualified electrician. Do NOT attempt to modify the plug in any way.

DO NOT OPERATE APPLIANCE IF THE POWER CORD SHOWS ANY DAMAGE OR IF APPLIANCE WORKS INTERMITTENTLY OR STOPS WORKING ENTIRELY.

California Proposition 65:
(Applicable for California Residents only)



WARNING:
Cancer and Reproductive Harm -
www.P65Warnings.ca.gov.



Do not place the appliance on a stovetop or any other heatable surface.

FEATURES

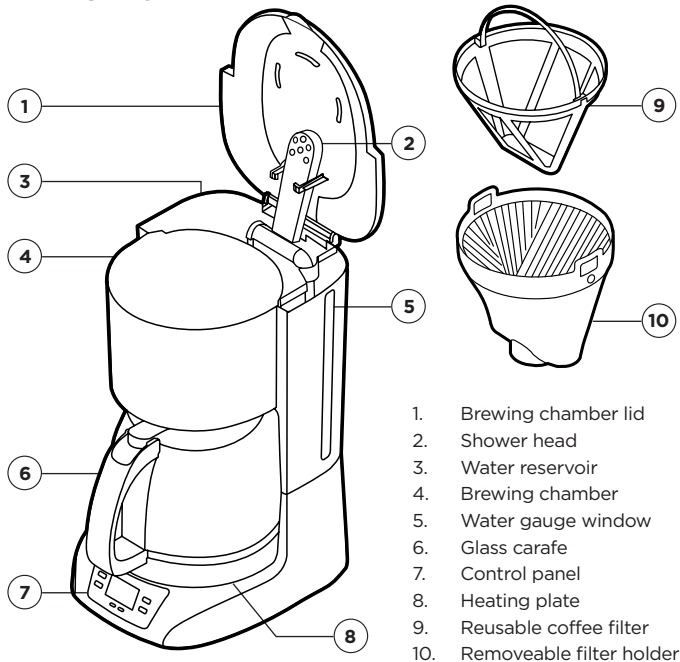

OPERATING INSTRUCTIONS

For best results, run the coffee maker through two brewing cycles with just water (directions follow) to remove any dust or residues from manufacturing and shipping.

BEFORE FIRST USE

1. Remove all packaging materials, such as plastic bags and stickers. Ensure you have all parts and accessories before discarding packaging.
2. Wipe exterior of coffee maker with damp, lint-free cloth. Wash carafe, reusable filter, and filter holder in warm, soapy water.
3. Place coffee maker on a hard, flat surface, and plug it in. Set time if you like. (See directions on page 9.)
4. Fill carafe to the 12-cup line with cold water, then pour the water into the water reservoir at the back of the brewing chamber.
5. If not already in place, set the filter holder and reusable filter in the brewing chamber. First, lift the showerhead out of the way, then place filter holder with its handles in the 3:00 and 9:00 positions; press down on the handles to lock holder in place. Do not add ground coffee.
6. Close the brewing chamber lid, pressing down firmly to close.

OPERATING INSTRUCTIONS

7. Place the carafe with its lid closed on the heating plate.
8. Press the On button.
9. After the carafe has filled, turn off the coffee maker by pressing Off. Let cool for at least 10 minutes. Pour water out of carafe. Refill with fresh water, and repeat steps four through eight.

TO SET TIME

Simply press the hour and minute buttons until desired time is displayed. Hold the button down to quickly scroll through numbers; when the displayed number nears the desired setting, pulse the button to advance one digit at a time. The 24-hour clock differentiates between a.m. and p.m. and displays both; be sure to choose the right 12-hour time period when setting the time. The display will maintain the time so long as the coffee maker is plugged in and has power.

OPERATING INSTRUCTIONS

HOW TO MAKE COFFEE

1. Fill the carafe with fresh cold water to between the 4- and 12-cup lines, then pour the water into the water reservoir at the back of the brewing chamber.
2. Place the carafe with its lid closed on the heating plate making sure it's fully seated in the coffee maker.

CAUTION: If the carafe is not properly positioned, hot water or hot coffee can overflow.

3. Check that the filter holder is situated in the brewing chamber; if not, insert it. Then insert either the reusable coffee filter or a #4 paper cone filter into the filter holder. (Do not use both together or filter can clog and coffee can overflow.)
4. Add the desired amount of ground coffee using the measuring scoop provided if you like. Brew coffee with the coffee-to-water ratio you normally use. For a rich, full-bodied cup, we suggest one level scoop for each cup listed on carafe. Shut the lid to the brewing chamber, pressing down on it to close securely.

OPERATING INSTRUCTIONS

5. Press the On button. A red light below the time display will blink to indicate brewing has started; the light will continue to blink until the unit is turned off.

CAUTION: Never open the brewing chamber during brewing as the hot steam, water, and coffee within can cause injury. If water/coffee is not draining from the filter basket, unplug the unit and wait 10 minutes before opening and checking the filter.

6. When brewing ends, the water gauge will show the water reservoir is empty, but there will still be hot liquid in the filter, so it's best to wait for a minute or two before serving to allow for the rest of the liquid to drip into the carafe before serving.

CAUTION: Coffee maker becomes very hot during the brew cycle. Please handle with extreme care.

7. The heating plate will operate so long as the coffee maker is on, keeping coffee hot. The coffee maker will shut off automatically two hours after the brewing cycle begins. As soon as the carafe is empty, or when you no longer want coffee kept hot, turn off the coffee maker manually by pressing the Off button. Though the heating plate will stop heating if it senses the carafe is empty, it's always best to turn the coffee maker off when the carafe is empty.

OPERATING INSTRUCTIONS

HOW TO PROGRAM FOR AUTO BREWING

Enjoy a fresh-made pot of coffee as soon as you wake up by programming the brewing to start automatically at your choice of time up to 24 hours in advance.

1. Before programming, be sure current time is set on the coffee maker.
2. Prepare coffee maker with ground coffee and water as if you are going to brew right away; do not press On.
3. Press the Pro button; the word Program will appear in the upper left corner of the time display to indicate an auto brew time is being set. Set the time you want brewing to begin by using the Hour and Min buttons. Once auto-brew time is set, the word Auto will appear in the time display. Your coffee maker will automatically begin brewing at the pre-set time. When the brew cycle begins, the red light will flash to indicate the coffee maker is in operation.

NOTE: To check auto-brew time, press the Pro button. To cancel auto brewing, hold the Pro button down until the word Auto disappears from the display, about 3 seconds.

OPERATING INSTRUCTIONS

HOW TO USE THE PAUSE AND SERVE FUNCTION

The pause and serve function interrupts coffee flow to let you pour a cup before brewing has finished. To pause the flow, simply remove the carafe from the heating plate any time during brewing. When returning the carafe, be sure to reposition it firmly against the back of the coffee maker for the flow to continue.

NOTE: While pause and serve is a convenient way to pour a cup of coffee mid-cycle, it's better to wait until brewing is complete as the strength of the coffee poured mid-cycle may vary from the finished brew and will affect the finished brew's strength and flavor.

CLEANING AND MAINTENANCE

1. Allow the coffee maker to cool completely before cleaning.
2. Lift the brewing chamber cover and shower head. Lift the filter holder out by grabbing its two handles and lifting straight up. Remove and discard the used coffee grinds and paper filter, if using.
3. Wash carafe/carafe lid, reusable filter, scoop, and filter holder in hot, sudsy water, or place in top rack of the dishwasher. Do not place any other parts of your coffee maker in the dishwasher.
4. To clean exterior of unit, simply wipe with a soft, damp cloth.
5. The heating plate may be wiped with a clean damp cloth as necessary. For hard-to-remove stains, use a plastic mesh pad or cloth dampened in vinegar.
6. Never use harsh or abrasive cleansers on any part of your coffeemaker

CAUTION: Never immerse the heating plate or main housing in water or any other liquid. Do not try to clean the inside of the water chamber with a cloth; this can leave a residue of lint and may clog your coffee maker.

CLEANING AND MAINTENANCE

HOW TO DECALCIFY YOUR COFFE MAKER

Calcium build-up frequently occurs in drip coffee makers. This build-up is normal and is caused by minerals commonly found in drinking water. We recommend decalcifying your coffee maker four times a year, and more often as needed. You'll know your coffee maker needs decalcifying when you notice an obvious slowing of the brewing time. We suggest using a mixture of vinegar and water to remove calcium or other mineral deposits that may form. Here's how:

1. Put 2 tablespoons of white vinegar in the carafe then fill the carafe to the 12-cup line with cold water.
2. Pour this solution into the water reservoir.
3. Follow normal brewing operation but without coffee or a filter in the filter holder.
4. When the brew cycle is finished, empty the carafe and rinse with water. Let coffee maker cool for 10 minutes.
5. Refill the water reservoir with cold water only and repeat the cycle, with water only, two more times to rinse out any remaining vinegar solution.

COFFEE MAKING TIPS

For best results, use a medium-fine grind of coffee—too fine can clog the coffee filter—and don't make less than four cups.

For best flavor, consider using bottled or filtered water.

Experiment with the amount of ground coffee used and adjust the amount to suit your taste.

If making multiple pots of coffee, allow the coffee maker to cool for 10 minutes between each brewing. Use a new disposable filter or rinse the reusable filter after each brewing.

TERMS AND CONDITIONS

Limited Warranty

Our products are backed by a limited 1-year warranty. To register, follow the instructions on the Chefman® Warranty Registration page in this User Guide.

We offer a limited 1-year warranty from the date of purchase. This warranty is void without proof of purchase within the USA, Canada, or Mexico. Service centers and retail stores do not have the right to alter or change the Terms and Conditions of this warranty.

WHAT THE WARRANTY COVERS

- **Manufacturer Defects**

Chefman® products are warranted against defects in material and workmanship for a period of 1 year from the date of purchase when used in accordance with the Chefman® User Guide.

- **Qualified Replacements**

If your product does not work as it should, we will send you a new one. If the product is no longer available, we will replace it with one that is comparable.

TERMS AND CONDITIONS

Limited Warranty

THIS WARRANTY DOES NOT COVER

- **Misuse** - Damage that occurs from neglectful or improper use of products; damage that occurs as a result of usage with incompatible voltage. See Safety Instructions for information on proper use.
- **Poor Maintenance** - General lack of proper care. See Cleaning and Maintenance for information on proper maintenance.
- **Commercial Use** - Damage that occurs from commercial use.
- **Altered Products** - Damage that occurs from alterations or modifications by any entity other than Chefman®; removal of rating label.
- **Catastrophic Events** - Damage that occurs from fire, floods, or natural disasters.
- **Loss of Interest** - Claims of loss of interest or enjoyment.

CHEFMAN® WARRANTY REGISTRATION

Register your product to add an additional 3 months to your warranty.

What do I Need to Register my Product?

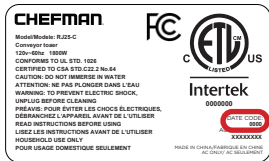

- Contact Information
- Model Number
- Proof of Purchase (online confirmation, receipt, gift receipt)
- Date code

NOTE: Label depicted here is an example.

How Do I Register my Product?

We offer two convenient ways to access the Chefman® registration form:

1. Visit chefman.com/register
2. Scan the QR code below to access site:



CHEFMAN® WARRANTY REGISTRATION

Have a Question?

Please reach out to us at Chefman.com/contact

Need More Help?

We're here for you! Contact us at customersupport@chefman.com or 888.315.6553 Monday-Friday.

OTHER LIMITATIONS: ALL WARRANTIES OF ANY KIND WHATSOEVER, EXPRESS, IMPLIED AND STATUTORY, ARE HEREBY DISCLAIMED. ALL IMPLIED WARRANTIES OF MERCHANTABILITY AND FITNESS FOR A PARTICULAR PURPOSE ARE HEREBY DISCLAIMED, PROVIDED THAT IF ANY IMPLIED WARRANTIES OF ANY KIND IS REQUIRED BY ANY JURISDICTION, INCLUDING MERCHANTABILITY AND FITNESS FOR A PARTICULAR PURPOSE, THE DURATION OF SUCH IMPLIED WARRANTY IS LIMITED TO ONE (1) YEAR. THIS WARRANTY DOES NOT COVER, AND CHEFMAN® SHALL NOT BE LIABLE FOR, INCIDENTAL, INDIRECT, SPECIAL OR CONSEQUENTIAL DAMAGES, INCLUDING WITHOUT LIMITATION, DAMAGE TO, OR LOSS OF USE OF THE PRODUCT, OR LOST SALES OR PROFITS OR DELAY OR FAILURE TO PERFORM THIS WARRANTY OBLIGATION. THE REMEDIES PROVIDED HEREIN ARE THE EXCLUSIVE REMEDIES UNDER THIS WARRANTY, WHETHER BASED ON CONTRACT, TORT OR OTHERWISE.

This Warranty gives you specific legal rights, and you may also have other rights that vary from state to state or province to province. Some states or provinces do not allow the exclusions or limitations set forth in this Warranty, so the above limitations or exclusions may not apply to you depending on the jurisdiction of purchase.

Chefman® is a registered trademark of RJ BRANDS, LLC.

CHEFMAN®

@mychefman



www.chefman.com

©CHEFMAN 2020