

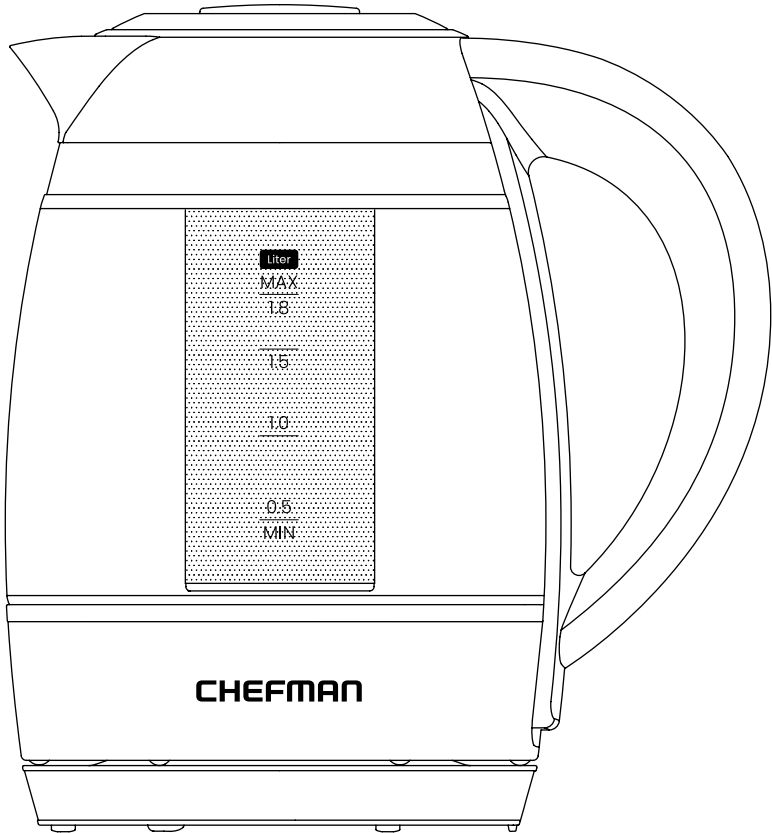

CHEFMAN.

Lightning™
1.8L Custom-
Temp Electric
Kettle



RJ11-18-CTI-HP-SERIES



Get to Know Your Kettle

1. Drip-free spout (with filter)
2. Removable lid
3. Temperature display
4. BOIL button
5. SET TEMP button
6. START/STOP button
7. Stay-cool handle
8. 360° swivel power base
9. Tricolor LED indicator lights
10. Borosilicate glass kettle
(with water-level markings)
11. Tea infuser (attaches to lid)



READ ALL INSTRUCTIONS BEFORE USE

For your safety and continued enjoyment of this product, always read the instruction manual before using.





Get to Know Your Kettle

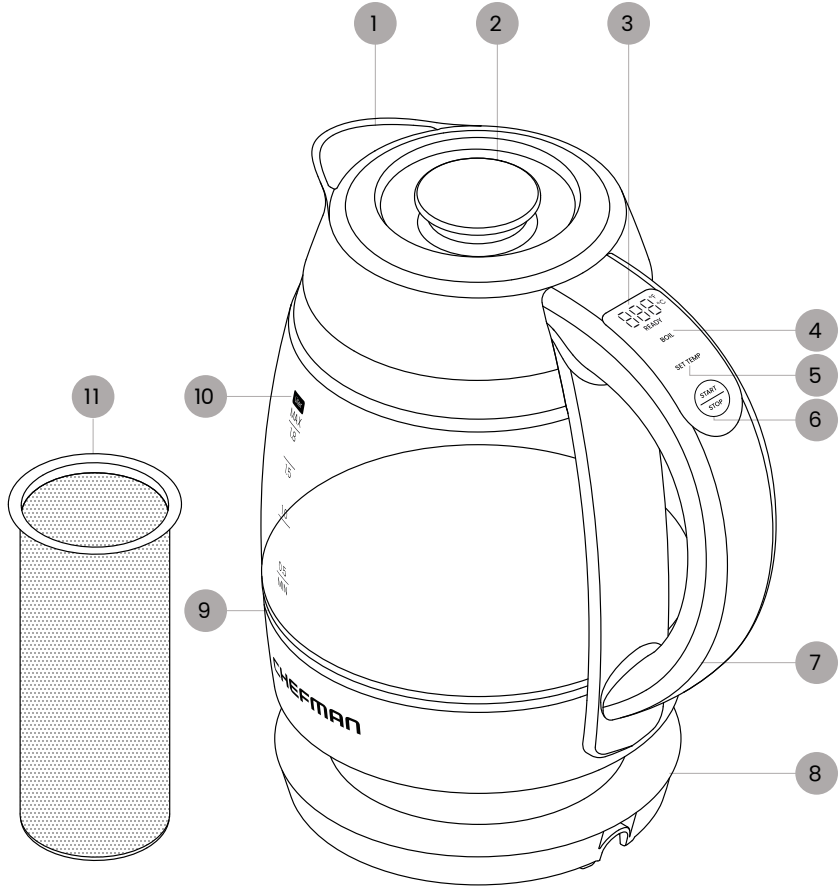



SAFETY INSTRUCTIONS & IMPORTANT SAFEGUARDS

When using electrical appliances, basic safety precautions should always be followed, including:

1. Read all instructions.
2. **Do NOT** touch hot surfaces. Use handles or knobs.
3. To protect against fire, electrical shock, and injury to persons, do not immerse the cord, plug, charging base, or unit in water or other liquids.
4. Close supervision is necessary when any appliance is used by or near children.
5. Unplug from the outlet when not in use and before cleaning. Allow to cool before putting on or taking off parts, and before cleaning the appliance.
6. **Do NOT** operate any appliance with a damaged cord or plug, or after the appliance malfunctions or has been damaged in any manner. If this should occur, contact Chefman® Customer Support for examination, repair, or adjustment.
7. The use of accessory attachments not recommended by Chefman® may result in fire, electrical shock, or injury to persons.
8. **Do NOT** use outdoors.
9. **Do NOT** let the cord hang over the edge of a table or counter or touch hot surfaces.
10. **Do NOT** place the unit near or on any type of heat source, such as a gas or electric burner, stove, or oven, even if not on. Do not use near an open flame or flammable materials.
11. To disconnect, turn any control to **OFF**, then remove the plug from the wall outlet.
12. Do not use the appliance for other than its intended use.
13. Scalding may occur if the lid is opened during the heating cycle.
14. Ensure the lid is securely closed before serving any beverages.
15. **Do NOT** set a hot container on a wet or cold surface.





SAFETY INSTRUCTIONS & IMPORTANT SAFEGUARDS

16. **Do NOT** use a cracked container or a container having a loose or weakened handle.
17. **Do NOT** clean the container with cleansers, steel wool pads, or other abrasive materials.



SAVE THESE INSTRUCTIONS FOR HOUSEHOLD USE ONLY





SAFETY INSTRUCTIONS & IMPORTANT SAFEGUARDS

WARNING: This appliance has a polarized plug (one blade is wider than the other). This plug is intended to fit into a polarized outlet only one way. If the plug does not fit fully into the outlet, reverse the plug. If it still does not fit, contact a qualified electrician. Do not attempt to modify the plug in any way or force it into the outlet. This could result in injury or electrical shock..

DO NOT alter the plug for use in a 2-prong outlet. If the plug will not fit into an outlet, have a proper outlet installed by a qualified electrician.

Short cord instructions

A short power-supply cord is provided to reduce the hazards of entanglement or tripping over a longer cord. Longer detachable power-supply cords or extension cords are available and may be used if care is exercised in their use. If a longer detachable power-supply extension cord is used:

1. The marked electrical rating of the extension cord should be at least as great as the electrical rating of the appliance.
2. The longer cord should be arranged so that it will not drape over the countertop or tabletop where it can be pulled on by children or tripped over.



SAFETY INSTRUCTIONS & IMPORTANT SAFEGUARDS

Power Cord Safety Tips

1. Never pull or yank on the cord or the appliance.
2. To insert the plug, grasp it firmly and guide it into the outlet.
3. To disconnect the appliance, grasp the plug and remove it from the outlet.
4. Never use the product if the power cord shows signs of abrasion or excessive wear. Contact Chefman® Customer Support for additional guidance and support.
5. Never wrap the cord tightly around the appliance, as this could place undue stress on the cord where it enters the appliance and cause it to fray and break.

DO NOT OPERATE THE APPLIANCE IF THE POWER CORD SHOWS ANY DAMAGE OR IF THE APPLIANCE WORKS INTERMITTENTLY OR STOPS WORKING ENTIRELY.



California Proposition 65:
(Applicable for California Residents only)
WARNING: Cancer and Reproductive Harm
www.P65Warnings.ca.gov

Do not place the appliance on a
stovetop or any other heatable surface,
even if stovetop is not on.
Doing so is a fire hazard.





Before First Use



To rinse the pot of any packing debris, “brew” a pot of plain water without tea. To do so, follow the directions below.

1. Remove all packing materials. Be sure that all parts are included before discarding any packaging.
2. Pull out the power cord from the compartment under the base, and place the base on a flat surface. (Make sure the power cord comes out of the opening in the base so the unit can sit level.)
3. To rinse the pot of any manufacturing residue, “brew” a pot of plain water without tea. To do so, lift off the lid and fill the kettle with water to the **MAX** line.
4. Put the lid with the infuser attached (but empty) back on the kettle. Place the kettle on the base unit, and plug it into a power outlet.
5. To switch between Fahrenheit and Celsius, if desired, press and hold the **SET TEMP** button for 3 seconds. Turn the kettle on by pressing **START/STOP**. The red LED lights inside the kettle will illuminate to indicate the water is heating.
6. Once the kettle boils, empty it (discarding the water), then rinse it with fresh water.





Quick Start: How to Use the Kettle

How to make tea with the infuser

1. Place the base on a flat surface.
2. Remove the lid. Remove the infuser from the lid by twisting it and sliding it in the direction indicated on the lid.
3. Fill the kettle to at least the **MIN** line (0.5 litres) and not above the **MAX** line (1.8 litres) with cold, fresh water. Return just the lid to the pot, and place the kettle securely onto its base.
4. Plug in the unit. The kettle will beep once and the LED ring near the kettle's base will light up in white, meaning it's in Standby mode.
5. After 2 seconds, the default temperature of 212°F will display on the screen (after first use, the kettle will default to your previously used temperature). To choose a different temperature, press the **SET TEMP** button repeatedly to toggle through the available choices (see table on p. 12). You can also press the **BOIL** button to quickly jump to 212°F (full boil). To switch between Fahrenheit and Celsius, press and hold the **SET TEMP** button for 3 seconds.
6. When your desired temperature displays on the screen, press **START/STOP** to begin heating. The LED ring at the base will turn red, to indicate it's heating. During heating, the water's current temperature will display on the screen.
7. Meanwhile, add tea to the infuser. Use loose tea (about 2 teaspoons per cup) or tea bags based on the amount of water you're heating. (Wait to insert the infuser until the desired temperature has been reached.)

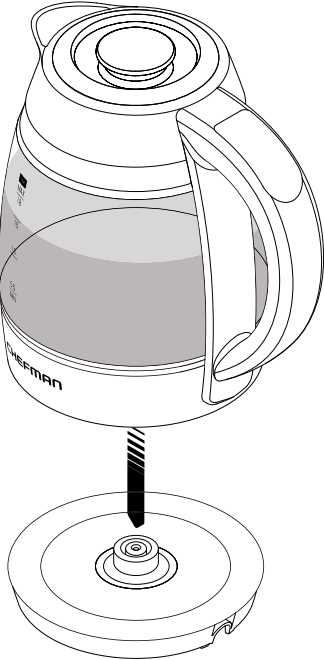



Quick Start: How to Use the Kettle

- When the kettle reaches the desired temperature, the kettle will beep three times, **READY** will display in green on the panel, and the LED ring at the kettle's base will turn green.
- Carefully lift off the kettle lid. Slide the tea-filled infuser onto the underside of the lid (a slight twist helps), insert it into the kettle, and press the lid to close.

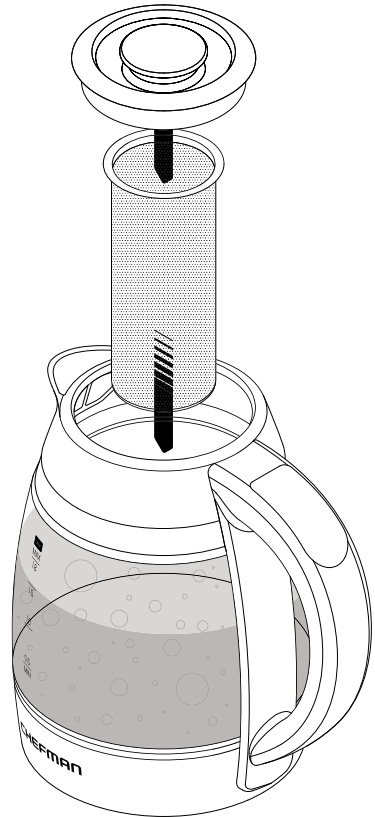
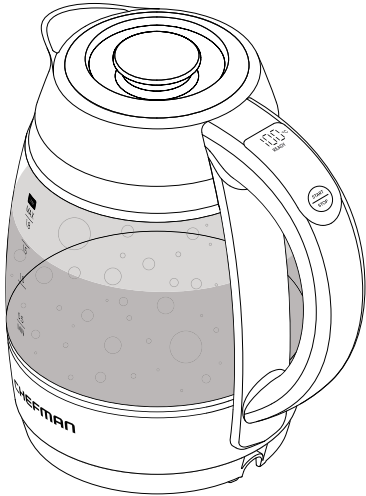



Quick Start: How to Use the Kettle

10. Let tea steep according to directions or as you like. When finished steeping, remove from the base and serve.

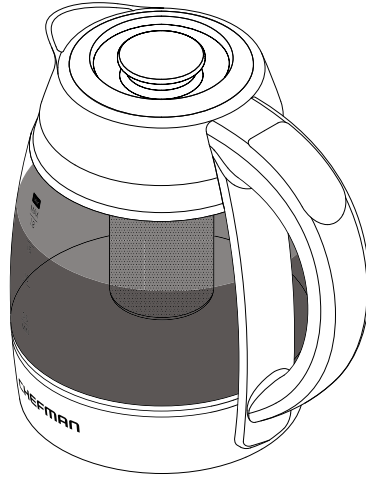

11. If you would like to remove the infuser and return the lid to the pot, carefully lift off the lid, then let the infuser cool (you can run it under water). Carefully twist/pull the infuser off, and return the lid to the kettle.





Quick Start: How to Use the Kettle

How to heat water without making tea

Follow the directions for making tea with the infuser but leave the tea and infuser out of the kettle. Use hot water as desired.

Boil-dry protection

The kettle comes equipped with boil-dry protection. While you should never heat the kettle without water at least to the **MIN** line (0.5 litres), should the unit go dry or start without water, it will automatically shut off completely to avoid damaging the heating element. It will not come back on, even if you replace it on the base, until it has cooled down.

Automatic keep warm function

As soon as the kettle comes to a boil, its LED lights switch from red to green, indicating that it is in Keep Warm mode. The kettle will keep your water or tea hot for up to 1 hour. Lifting the kettle from its base will turn the Keep Warm function off.

Mute function

To mute the kettle's beeps, press and hold the **BOIL** button for 5 seconds. To turn the sound back on, simply press and hold the same button again for 5 seconds.

Brewing Temperature Guide

The chart below is intended as a starting point for brewing your perfect cup of tea. You may need to vary the amount of tea and steeping times based on the kind of tea, the size of the leaves, and your personal preference. The kettle also heats water to the perfect temperature for pour-over coffee (use a pour-over decanter and filter setup; do not put coffee in the tea infuser).

Beverage Type	Recommended Temperature (°F)
Delicate	160–165°F
Green	175°F
White	185°F
Oolong	195°F
Coffee	205°F
Herbal	212°F
Black	212°F





Keep It Clean

1. Unplug the kettle and allow it to cool completely before cleaning.
2. Clean the interior of the kettle as needed by removing the infuser and carefully washing the inside with soapy water. Rinse the inside of the kettle thoroughly. Wipe the outside of the kettle and power base with a damp cloth. **WARNING:** Never immerse the kettle or power base in water or wash in the dishwasher; doing so will damage the unit.
3. To clean the spout filter, rinse it under hot water while gently rubbing it with a clean cloth or brush. Do not remove the filter from the spout.
4. Wash the tea infuser in warm, soapy water and rinse thoroughly; the infuser is not dishwasher safe.

NOTE: Reheating tea in your kettle may result in a bronze-colored tea stain on the kettle. This is caused by tea residue that adheres when reheated at high temperatures. To avoid tea-staining, do not reheat the same pot of tea twice, and always rinse the inside of your kettle before each brew. To remove the bronze-colored staining, add a small amount of food-grade white vinegar to a fresh kettle full of water and boil. After boiling, allow the kettle to cool, discard the water, and thoroughly wash and dry the kettle before your next use.

Decalcifying

Due to minerals in water, deposits may form on the base of the kettle and cause discoloration. To get the best performance from your kettle, decalcify it from time to time. Frequency will depend on the hardness of your water and how often you use the kettle. You can either use a commercial descaler (following the package directions) or use vinegar and water, and follow the directions below:

1. Fill the kettle with enough white vinegar to cover the bottom by about 13 mm ($\frac{1}{2}$ inch). Heat the vinegar to a boil.
2. Repeat this process with fresh vinegar until all deposits are removed.
3. When the descaling process is complete, empty the kettle and rinse it out several times with clean water.



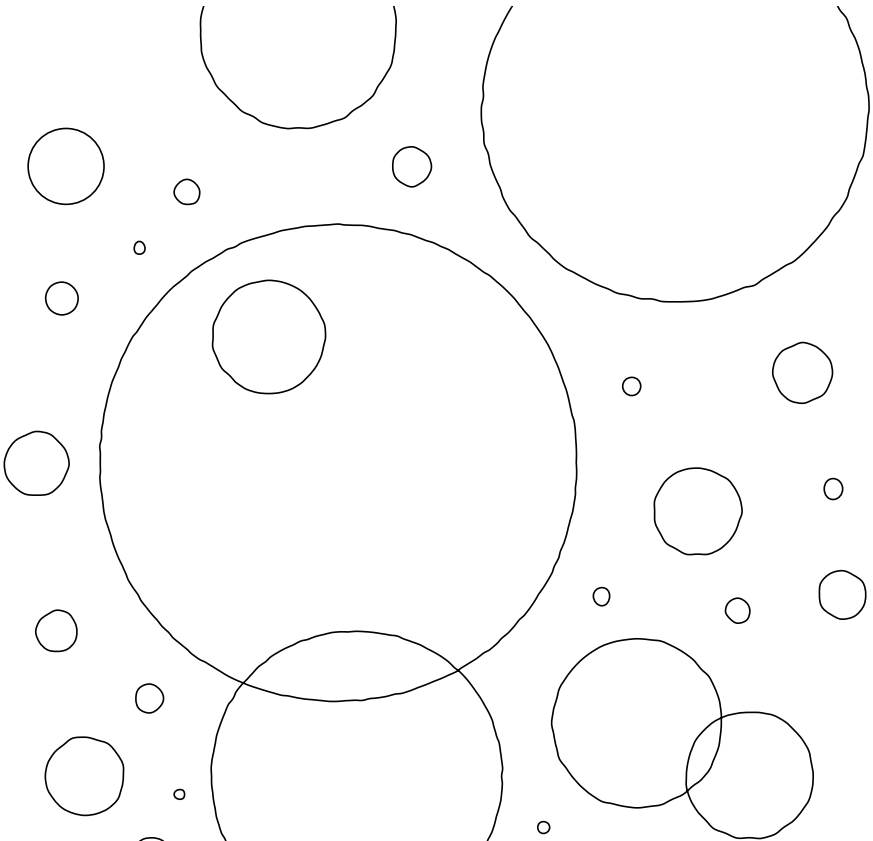

CHEFMAN BOILS FASTER™





Terms & Conditions

Limited Warranty

RJ Brands, LLC d/b/a Chefman® offers a limited 1-year Warranty (the “Warranty”) available on sales through authorized distributors and retailers only. Please note that this Warranty becomes valid from the date of initial retail purchase and that the Warranty is non-transferable and applies only to the original purchaser.

This Warranty is void without proof of purchase within the United States and Canada. Please be aware that this Warranty supersedes all other warranties and constitutes the entire agreement between the consumer and Chefman®. Any changes to the Terms and Conditions of this Warranty must be in writing, signed by a representative of Chefman®. No other party has the right or ability to alter or change the Terms and Conditions of this Warranty.

We may ask you to please submit, via email, photos and/or video of the issue you are experiencing. This is to help us better assess the matter and possibly offer a quick fix. Photos and/or video may also be required to determine Warranty eligibility.

We encourage you to register your product. Registering can make the Warranty process easier and can keep you informed of any updates or recalls on your product. To register, follow the directions on the Chefman® Warranty Registration page in the Chefman® User Guide. Please retain your proof of purchase even after registering. In the event that you do not have proof of your purchase date, we may declare your Warranty void or we may, at our sole discretion, apply the date of manufacture as the purchase date for purposes of this Warranty.





Terms & Conditions

What the Warranty Covers

- **Manufacturer Defects** - Chefman® products are warranted against defects in material and workmanship, under normal household use, for a period of 1 year from the date of purchase when used in accordance with the directions listed in the Chefman® User Guide. If your product does not work as it should, please contact Customer Support at support@chefman.com so that we may assist you.

This Warranty Does Not Cover

- **Misuse**
Damage that occurs from neglectful or improper use of products, including, but not limited to, damage that occurs as a result of usage with incompatible voltage, regardless of whether the product was used with a converter or adapter. See Safety Instructions in the Chefman® User Guide for information on proper use of product;
- **Poor Maintenance**
General lack of proper care. We encourage you to take care of your Chefman® products so that you may continue to enjoy them. Please see Cleaning and Maintenance directions in the Chefman® User Guide for information on proper maintenance;
- **Commercial Use**
Damage that occurs from commercial use;
- **Normal Wear and Tear**
Damage or degradation expected to occur due to normal use over time;
- **Altered Products**
Damage that occurs from alterations or modifications by any entity other than Chefman® such as the removal of the rating label affixed to the product;
- **Catastrophic Events** - Damage that occurs from fire, floods, or natural disasters; or
- **Loss of Interest** - Claims of loss of interest or enjoyment.





Terms & Conditions

[For product information, please visit us at Chefman.com.](http://Chefman.com)

EXCEPT WHERE SUCH LIABILITY IS REQUIRED BY LAW, THIS WARRANTY DOES NOT COVER, AND CHEFMAN® SHALL NOT BE LIABLE FOR, INCIDENTAL, INDIRECT, SPECIAL, OR CONSEQUENTIAL DAMAGES, INCLUDING WITHOUT LIMITATION, DAMAGE TO, OR LOSS OF USE OF THE PRODUCT, OR LOST SALES OR PROFITS OR DELAY OR FAILURE TO PERFORM THIS WARRANTY OBLIGATION. THE REMEDIES PROVIDED HEREIN ARE THE EXCLUSIVE REMEDIES UNDER THIS WARRANTY, WHETHER BASED ON CONTRACT, TORT OR OTHERWISE.





Warranty Registration

What do I need to register my product?

- Contact Information
- Model Number (see example below)
- Proof of Purchase (online confirmation, receipt, gift receipt)
- Date Code (see example below)
- Access Code (see example below)

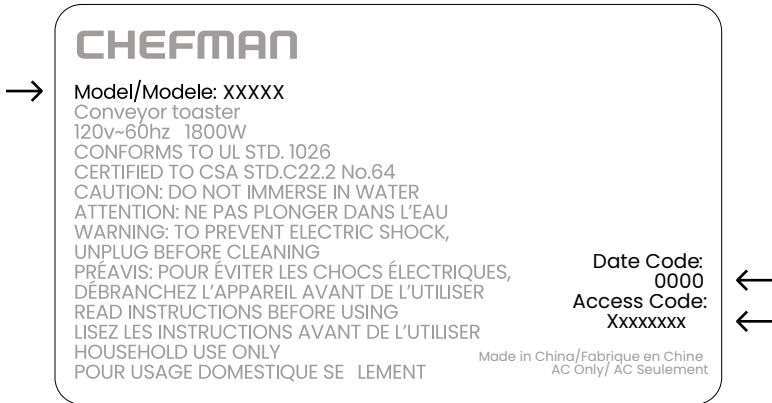

NOTE: Label depicted here is an example.

Please see label on your product for actual model/date code/access code.

How do I register my product?

All you need to do is fill out a simple Chefman® registration form. You can easily access the form in one of the two ways listed below:

- Visit Chefman.com/register.
- Scan the QR code to the right to access site.





CHEFMAN.

Lightning™
1.8L Custom-Temp
Electric Kettle

RJTBCTHPSERIESUG060524

Chefman Boils Faster™ is a trademark of RJ Brands, LLC.

Chefman® is a registered trademark of RJ Brands, LLC.